

First edition  
2008-06-15

---

---

**Rolling bearings — Methods for  
calculating the modified reference rating  
life for universally loaded bearings**

*Roulements — Méthodes de calcul de la durée nominale de référence  
corrigée pour les roulements chargés universellement*



Reference number  
ISO/TS 16281:2008(E)

© ISO 2008

**PDF disclaimer**

This PDF file may contain embedded typefaces. In accordance with Adobe's licensing policy, this file may be printed or viewed but shall not be edited unless the typefaces which are embedded are licensed to and installed on the computer performing the editing. In downloading this file, parties accept therein the responsibility of not infringing Adobe's licensing policy. The ISO Central Secretariat accepts no liability in this area.

Adobe is a trademark of Adobe Systems Incorporated.

Details of the software products used to create this PDF file can be found in the General Info relative to the file; the PDF-creation parameters were optimized for printing. Every care has been taken to ensure that the file is suitable for use by ISO member bodies. In the unlikely event that a problem relating to it is found, please inform the Central Secretariat at the address given below.



**COPYRIGHT PROTECTED DOCUMENT**

© ISO 2008

All rights reserved. Unless otherwise specified, no part of this publication may be reproduced or utilized in any form or by any means, electronic or mechanical, including photocopying and microfilm, without permission in writing from either ISO at the address below or ISO's member body in the country of the requester.

ISO copyright office  
Case postale 56 • CH-1211 Geneva 20  
Tel. + 41 22 749 01 11  
Fax + 41 22 749 09 47  
E-mail [copyright@iso.org](mailto:copyright@iso.org)  
Web [www.iso.org](http://www.iso.org)

Published in Switzerland

# Contents

Page

Foreword.....	iv
Introduction .....	v
<b>1</b> <b>Scope .....</b>	<b>1</b>
<b>2</b> <b>Normative references .....</b>	<b>1</b>
<b>3</b> <b>Symbols .....</b>	<b>2</b>
<b>4</b> <b>Ball bearings .....</b>	<b>4</b>
4.1 <b>General.....</b>	<b>4</b>
4.2 <b>Bearing internal load distribution .....</b>	<b>4</b>
4.3 <b>Rating life.....</b>	<b>7</b>
<b>5</b> <b>Roller bearings.....</b>	<b>9</b>
5.1 <b>General.....</b>	<b>9</b>
5.2 <b>Bearing internal load distribution .....</b>	<b>10</b>
5.3 <b>Rating life.....</b>	<b>13</b>
<b>6</b> <b>Reference geometries .....</b>	<b>17</b>
6.1 <b>General.....</b>	<b>17</b>
6.2 <b>Cylindrical roller bearings and needle roller bearings .....</b>	<b>17</b>
6.3 <b>Deep groove ball bearings, angular contact ball bearings and separable ball bearings.....</b>	<b>17</b>
6.4 <b>Spherical roller bearings.....</b>	<b>17</b>
6.5 <b>Tapered roller bearings.....</b>	<b>17</b>
6.6 <b>Self-aligning ball bearings .....</b>	<b>18</b>
6.7 <b>Thrust cylindrical roller bearings and thrust needle roller bearings .....</b>	<b>18</b>
6.8 <b>Thrust ball bearings and thrust angular contact ball bearings .....</b>	<b>18</b>
6.9 <b>Thrust spherical roller bearings.....</b>	<b>18</b>
6.10 <b>Thrust tapered roller bearings.....</b>	<b>18</b>
<b>7</b> <b>Life modification factor, <math>a_{ISO}</math>, and contamination factor, <math>e_C</math> .....</b>	<b>18</b>
7.1 <b>General.....</b>	<b>18</b>
7.2 <b>Life modification factor .....</b>	<b>18</b>
7.3 <b>Contamination factor.....</b>	<b>19</b>
<b>8</b> <b>Fatigue load limit and basic dynamic load rating .....</b>	<b>19</b>
<b>Bibliography .....</b>	<b>20</b>

## Foreword

ISO (the International Organization for Standardization) is a worldwide federation of national standards bodies (ISO member bodies). The work of preparing International Standards is normally carried out through ISO technical committees. Each member body interested in a subject for which a technical committee has been established has the right to be represented on that committee. International organizations, governmental and non-governmental, in liaison with ISO, also take part in the work. ISO collaborates closely with the International Electrotechnical Commission (IEC) on all matters of electrotechnical standardization.

International Standards are drafted in accordance with the rules given in the ISO/IEC Directives, Part 2.

The main task of technical committees is to prepare International Standards. Draft International Standards adopted by the technical committees are circulated to the member bodies for voting. Publication as an International Standard requires approval by at least 75 % of the member bodies casting a vote.

In other circumstances, particularly when there is an urgent market requirement for such documents, a technical committee may decide to publish other types of document:

- an ISO Publicly Available Specification (ISO/PAS) represents an agreement between technical experts in an ISO working group and is accepted for publication if it is approved by more than 50 % of the members of the parent committee casting a vote;
- an ISO Technical Specification (ISO/TS) represents an agreement between the members of a technical committee and is accepted for publication if it is approved by 2/3 of the members of the committee casting a vote.

An ISO/PAS or ISO/TS is reviewed after three years in order to decide whether it will be confirmed for a further three years, revised to become an International Standard, or withdrawn. If the ISO/PAS or ISO/TS is confirmed, it is reviewed again after a further three years, at which time it must either be transformed into an International Standard or be withdrawn.

Attention is drawn to the possibility that some of the elements of this document may be the subject of patent rights. ISO shall not be held responsible for identifying any or all such patent rights.

ISO/TS 16281 was prepared by Technical Committee ISO/TC 4, *Rolling bearings*, Subcommittee SC 8, *Load ratings and life*.

## Introduction

Since publication of ISO 281 in 1990, additional knowledge has been gained regarding the influence on bearing life of contamination, lubrication, internal stresses from mounting, stresses from hardening, fatigue load limit of the material etc. It is therefore now possible to consider factors that have influence on bearing life in a more complete way in the life calculation.

ISO 281:2007 provides a method to put into practice this new knowledge in a consistent way when the modified rating life of a bearing is calculated. However, the calculation method given in ISO 281:2007 cannot consider the influence on life of tilted or misaligned bearings and the influence on life of bearing clearance during operation. This Technical Specification describes an advanced calculation method, which also makes it possible to consider these influences, and by that in addition provide the most accurate support for estimating the influence of contamination and other factors.

www.iso.org

Copyright International Organization for Standardization

# Rolling bearings — Methods for calculating the modified reference rating life for universally loaded bearings

## 1 Scope

This Technical Specification contains recommendations for the calculation of the modified reference rating life taking into consideration lubrication, contamination and fatigue load limit of the bearing material, as well as tilting or misalignment, operating clearance of the bearing and internal load distribution on rolling elements. The calculation method provided in this Technical Specification covers influencing parameters additional to those described in ISO 281.

The directions and limitations given in ISO 281 apply to this Technical Specification. The calculation methods pertain to the fatigue life of the bearings. Other mechanisms of failure, like wear or microspalling (gray staining), lie outside the scope of this Technical Specification.

This Technical Specification applies to tilted single-row radial ball bearings, subjected to radial and axial load and with radial clearance and tilt taken into account. It also applies to tilted single-row roller bearings, subjected to pure radial load and with radial clearance, edge stress and tilt taken into account. References to methods for the analysis of the internal load distribution under general load are given.

The analysis of internal load distribution and modified reference rating life for multi-row bearings or bearings of a more complex geometry can be derived from the equations given in this Technical Specification. For these bearings, the load distribution for each individual row has to be considered.

This Technical Specification is primarily intended to be used for computer programs and together with ISO 281 covers the information needed for life calculations. For accurate life calculations under the operating conditions specified above, it is recommended that either this Technical Specification or advanced computer calculations provided by bearing manufacturers, for determining the dynamic equivalent reference load under different loading conditions, be used.

## 2 Normative references

The following referenced documents are indispensable for the application of this document. For dated references, only the edition cited applies. For undated references, the latest edition of the referenced document (including any amendments) applies.

ISO 281:2007, *Rolling bearings — Dynamic load ratings and rating life*

ISO 15241, *Rolling bearings — Symbols for quantities*

### 3 Symbols

For the purpose of this document, the symbols given in ISO 15241 and the following apply. See also the terms and definitions in ISO 281:2007, Clause 3 and other definitions in ISO 281.

$A$	distance, in millimetres, between raceway groove curvature centres of ball bearing having no clearance and having an initial contact angle
$a_{\text{ISO}}$	life modification factor, based on a systems approach of life calculation
$a_1$	life modification factor for reliability
$C_a$	basic dynamic axial load rating, in newtons
$C_r$	basic dynamic radial load rating, in newtons
$C_u$	fatigue load limit, in newtons
$c_L$	spring constant, in newtons per millimetre to the power of 10/9, of a rolling element with line contact
$c_P$	spring constant, in newtons per millimetre to the power of 3/2, of a rolling element with point contact
$c_s$	spring constant, in newtons per millimetre to the power of 8/9, of a roller lamina
$D_{\text{pw}}$	pitch diameter, in millimetres, of ball or roller set
$D_w$	nominal ball diameter, in millimetres
$D_{\text{we}}$	roller diameter, in millimetres, applicable in the calculation of load ratings
$E$	modulus of elasticity, in megapascals <sup>1)</sup>
$E(\chi)$	complete elliptic integral of the second kind
$e$	subscript for outer ring or housing washer
$e_C$	contamination factor
$F(\rho)$	relative curvature difference
$F_a$	bearing axial load (axial component of actual bearing load), in newtons
$F_r$	bearing radial load (radial component of actual bearing load), in newtons
$f[j,k]$	stress correction function for consideration of edge load
$i$	subscript for inner ring or shaft washer
$i$	number of rows of rolling elements
$K(\chi)$	complete elliptic integral of the first kind
$L_{\text{nmr}}$	modified reference rating life, in million revolutions
$L_{\text{we}}$	effective roller length, in millimetres, applicable in the calculation of load ratings
$L_{10r}$	basic reference rating life, in million revolutions
$M_z$	moment, in newton millimetres, acting on tilted bearing

---

1) 1 MPa = 1 N/mm<sup>2</sup>



$n_s$	number of laminae
$P_{\text{ref,a}}$	dynamic equivalent reference axial load, in newtons
$P_{\text{ref,r}}$	dynamic equivalent reference radial load, in newtons
$P(x)$	profile function, in millimetres
$p_{\text{He}}$	contact stress, in megapascals, at the contact of outer ring and rolling element
$p_{\text{Hi}}$	contact stress, in megapascals, at the contact of inner ring and rolling element
$P_{ks}$	dynamic equivalent load, in newtons, of a bearing lamina $k$
$Q$	rolling element load, in newtons
$Q_{\text{ce}}$	rolling element load, in newtons, for the basic dynamic load rating of outer ring or housing washer
$Q_{\text{ci}}$	rolling element load, in newtons, for the basic dynamic load rating of inner ring or shaft washer
$Q_{\text{ee}}$	dynamic equivalent rolling element load, in newtons, on outer ring or housing washer
$Q_{\text{ei}}$	dynamic equivalent rolling element load, in newtons, on inner ring or shaft washer
$Q_j$	rolling element load, in newtons, of rolling element $j$
$q_{\text{ce}}$	basic dynamic load rating, in newtons, of a bearing lamina at the outer ring or housing washer contact
$q_{\text{ci}}$	basic dynamic load rating, in newtons, of a bearing lamina at the inner ring or shaft washer contact
$q_{\text{ee}}$	dynamic equivalent load, in newtons, of a bearing lamina at the outer ring or housing washer contact
$q_{\text{ei}}$	dynamic equivalent load, in newtons, of a bearing lamina at the inner ring or shaft washer contact
$q_{j,k}$	load, in newtons, on the lamina $k$ of roller $j$
$R_i$	distance, in millimetres, between the centre of curvature of the inner race groove and the axis of rotation
$R_p$	crown radius, in millimetres, of spherical rollers
$r_e$	cross-sectional raceway groove radius, in millimetres, of outer ring or housing washer
$r_i$	cross-sectional raceway groove radius, in millimetres, of inner ring or shaft washer
$s$	radial operating clearance, in millimetres, of bearing
$x_k$	distance, in millimetres, between centre of lamina $k$ and roller centre
$Z$	number of rolling elements
$\alpha$	nominal contact angle, in degrees, of a bearing
$\alpha_j$	operating contact angle, in degrees, of the rolling element $j$
$\alpha_0$	initial contact angle, in degrees
$\gamma$	auxiliary parameter, $\gamma = D_w \cos \alpha / D_{pw}$
$\delta$	total elastic deflection, in millimetres, of both contacts of a rolling element
$\delta_j$	elastic deflection, in millimetres, of the rolling element $j$
$\delta_{j,k}$	elastic deflection, in millimetres, of the lamina $k$ of the roller $j$

$\delta_a$	relative axial displacement, in millimetres, of both bearing rings
$\delta_r$	relative radial displacement, in millimetres, of both bearing rings
$\lambda$	reduction factor for the consideration of stress concentrations
$\nu$	adjustment factor for exponent variation
$\nu_E$	Poisson's ratio
$\rho$	curvature, in reciprocal millimetres, of the contact surface
$\Sigma\rho$	curvature sum, in reciprocal millimetres
$\varphi_j$	angular position, in degrees, of rolling element $j$
$\chi$	ratio of semi-major to semi-minor axis of the contact ellipse
$\psi$	total misalignment, in degrees, between inner raceway and outer raceway
$\psi_j$	total misalignment, in degrees, between inner raceway and outer raceway in the plane of rolling element $j$

## 4 Ball bearings

### 4.1 General

This clause describes the analysis of the internal load distribution for radial ball bearings and thrust ball bearings under radial and axial load, taking into account radial clearance and tilt. Calculation methods concerning the analysis of bearings of different geometry or for more complex load cases can be derived from the equations given in this Technical Specification.

The bearing internal load distribution is calculated for a static equilibrium; dynamic effects like centripetal and gyroscopic forces are considered insignificant. This assumption is generally valid for low and moderate speeds. At high speeds, centripetal and gyroscopic forces can become predominant and significantly alter the bearing internal load distribution.

### 4.2 Bearing internal load distribution

#### 4.2.1 Elastic deflection of point contact

The elastic deflection of a point contact can be calculated from Hertzian theory. The elastic deflection of a single point contact,  $\delta$ , is given by

$$\delta = \sqrt[3]{4,5 \left( \frac{1 - \nu_E^2}{\pi E} \right)^2 K(\chi) \sqrt{\frac{\Sigma\rho}{\chi^2 E(\chi)}} Q^{2/3}} \quad (1)$$

The ratio,  $\chi$ , of the semi-major to semi-minor ellipses is the root of Equation (2)

$$1 - \frac{2}{\chi^2 - 1} \left[ \frac{K(\chi)}{E(\chi)} - 1 \right] - F(\rho) = 0 \quad (2)$$

with the complete elliptic integral of the first kind,  $K(\chi)$

$$K(\chi) = \int_0^{\pi/2} \left[ 1 - \left( 1 - \frac{1}{\chi^2} \right) (\sin \varphi)^2 \right]^{-1/2} d\varphi \quad (3)$$

and the complete elliptic integral of the second kind,  $E(\chi)$

$$E(\chi) = \int_0^{\pi/2} \left[ 1 - \left( 1 - \frac{1}{\chi^2} \right) (\sin \varphi)^2 \right]^{1/2} d\varphi \quad (4)$$

the curvature sum at the inner ring contact,  $\Sigma\rho_i$

$$\Sigma\rho_i = \frac{2}{D_w} \left( 2 + \frac{\gamma}{1-\gamma} - \frac{D_w}{2r_i} \right) \quad (5)$$

and curvature sum at the outer ring contact,  $\Sigma\rho_e$

$$\Sigma\rho_e = \frac{2}{D_w} \left( 2 - \frac{\gamma}{1+\gamma} - \frac{D_w}{2r_e} \right) \quad (6)$$

and the relative curvature difference at the inner ring contact,  $F_i(\rho)$

$$F_i(\rho) = \left( \frac{\gamma}{1-\gamma} + \frac{D_w}{2r_i} \right) / \left( 2 + \frac{\gamma}{1-\gamma} - \frac{D_w}{2r_i} \right) \quad (7)$$

and the relative curvature difference at the outer ring contact,  $F_e(\rho)$

$$F_e(\rho) = \left( \frac{-\gamma}{1+\gamma} + \frac{D_w}{2r_e} \right) / \left( 2 - \frac{\gamma}{1+\gamma} - \frac{D_w}{2r_e} \right) \quad (8)$$

The total elastic deflection of both contacts at inner ring and outer ring,  $\delta$ , is given by

$$\delta = \sqrt[3]{4,5 \left( \frac{1-\nu_E^2}{\pi E} \right)^2 \left[ K(\chi_i) \sqrt[3]{\frac{\Sigma\rho_i}{\chi_i^2 E(\chi_i)}} + K(\chi_e) \sqrt[3]{\frac{\Sigma\rho_e}{\chi_e^2 E(\chi_e)}} \right] Q^{2/3}} \quad (9)$$

This leads to Equation (10) for load-deflection

$$Q = c_P \delta^{3/2} \quad (10)$$

with the spring constant,  $c_P$

$$c_P = 1,48 \frac{E}{1-\nu_E^2} \left[ K(\chi_i) \sqrt[3]{\frac{\Sigma\rho_i}{\chi_i^2 E(\chi_i)}} + K(\chi_e) \sqrt[3]{\frac{\Sigma\rho_e}{\chi_e^2 E(\chi_e)}} \right]^{-3/2} \quad (11)$$

#### 4.2.2 Static equilibrium

For a radial ball bearing with diametrically measured radial operating clearance,  $s$ , having an initial contact angle,  $\alpha_0 = \arccos[1 - (s/2A)]$ , the total elastic deflection of the rolling element,  $\delta_j$ , is given by

$$\delta_j = \left\langle \sqrt{\left( A \cos \alpha_0 + \delta_r \cos \varphi_j \right)^2 + \left( A \sin \alpha_0 + \delta_a + R_i \sin \psi \cos \varphi_j \right)^2} - A \right\rangle \quad (12)$$

The right-hand side of Equation (12) is set to zero if it is negative.

NOTE The initial contact angle,  $\alpha_0$ , is generally not identical to the nominal contact angle,  $\alpha$ , in ISO 281.

In Equation (12),  $A$  is the distance between the curvature centres of the raceway groove radii,  $r_i$  and  $r_e$ , see Figure 1.

$$A = r_i + r_e - D_w \tag{13}$$

The distance between the centre of curvature of the inner raceway groove and the axis of rotation,  $R_i$ , is

$$R_i = \frac{D_{pw}}{2} + \left( r_i - \frac{D_w}{2} \right) \cos \alpha_0 \tag{14}$$

The contact loads can be calculated from the elastic deflection of the rolling elements using Equation (10). These contact loads act in the direction of the operating contact angle of the rolling element,  $\alpha_j$

$$\alpha_j = \arctan \left( \frac{A \sin \alpha_0 + \delta_a + R_i \sin \psi \cos \varphi_j}{A \cos \alpha_0 + \delta_r \cos \varphi_j} \right) \tag{15}$$

The static equilibrium conditions for the external forces and the moment acting on the bearing rings and the reaction forces of the rolling elements yield the equation system, which can be solved by iteration, in 4.2.2.1 and 4.2.2.2.

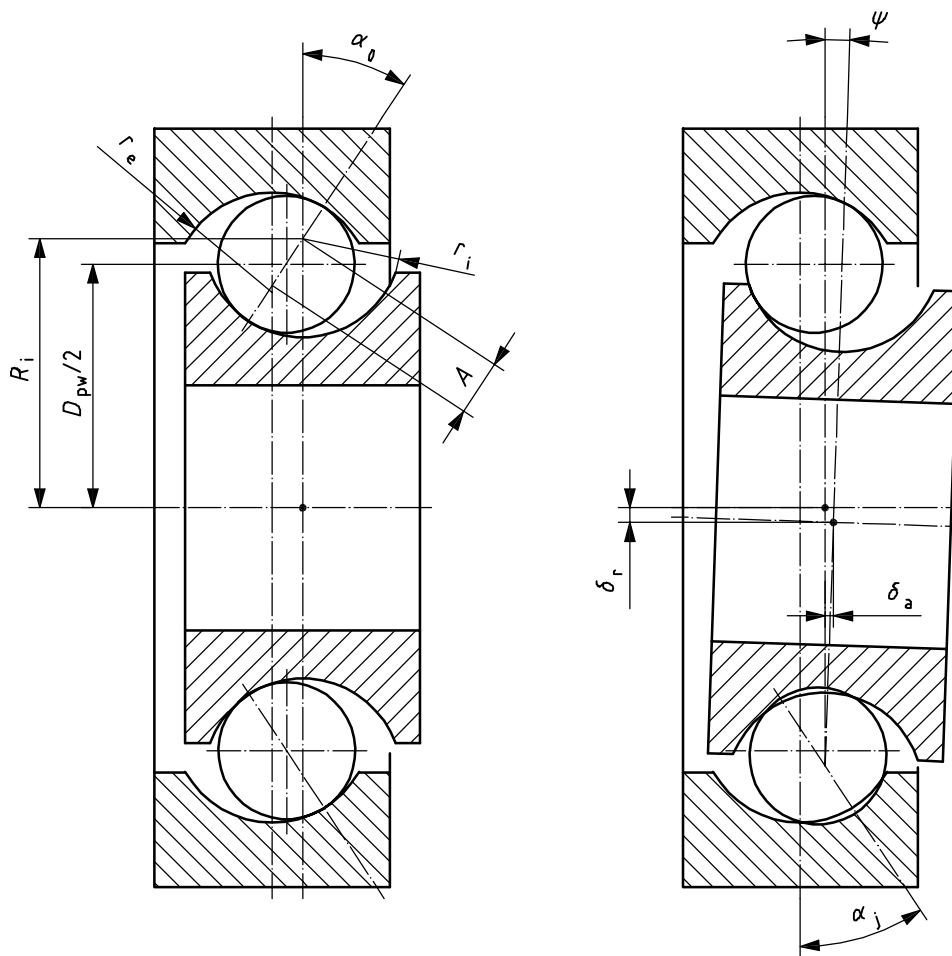

Figure 1 — Auxiliary geometry parameters

#### 4.2.2.1 Sum of all forces

$$F_r - c_P \sum_{j=1}^Z \delta_j^{3/2} \cos \alpha_j \cos \varphi_j = 0 \quad (16)$$

$$F_a - c_P \sum_{j=1}^Z \delta_j^{3/2} \sin \alpha_j = 0 \quad (17)$$

#### 4.2.2.2 Sum of all moments

$$M_z - \left( \frac{D_{pw}}{2} \right) c_P \sum_{j=1}^Z \delta_j^{3/2} \sin \alpha_j \cos \varphi_j = 0 \quad (18)$$

### 4.3 Rating life

#### 4.3.1 Rolling element load for the basic dynamic load rating

##### 4.3.1.1 General

The rolling element load for the basic dynamic load ratings for inner rings and outer rings,  $Q_{ci}$  and  $Q_{ce}$ , are derived from ISO/TR 1281-1 [1].

##### 4.3.1.2 Radial ball bearings

For the inner ring,  $Q_{ci}$  can be calculated by means of the basic dynamic radial load rating,  $C_r$ , for single-row and multi-row bearings.

$$Q_{ci} = \frac{C_r}{0,407 Z (\cos \alpha)_i^{0,7}} \left( 1 + \left\{ 1,044 \left( \frac{1-\gamma}{1+\gamma} \right)^{1,72} \left[ \frac{r_i}{r_e} \left( \frac{2r_e - D_w}{2r_i - D_w} \right) \right]^{0,41} \right\}^{10/3} \right)^{3/10} \quad (19)$$

For the outer ring,  $Q_{ce}$  can be calculated by means of the basic dynamic radial load rating,  $C_r$ , for single-row and multi-row bearings.

$$Q_{ce} = \frac{C_r}{0,389 Z (\cos \alpha)_i^{0,7}} \left( 1 + \left\{ 1,044 \left( \frac{1-\gamma}{1+\gamma} \right)^{1,72} \left[ \frac{r_i}{r_e} \left( \frac{2r_e - D_w}{2r_i - D_w} \right) \right]^{0,41} \right\}^{-10/3} \right)^{3/10} \quad (20)$$

##### 4.3.1.3 Thrust ball bearings with a nominal contact angle, $\alpha \neq 90^\circ$

For the inner ring or shaft washer,  $Q_{ci}$  can be calculated using the basic dynamic axial load rating,  $C_a$

$$Q_{ci} = \frac{C_a}{Z \sin \alpha} \left( 1 + \left\{ \left( \frac{1-\gamma}{1+\gamma} \right)^{1,72} \left[ \frac{r_i}{r_e} \left( \frac{2r_e - D_w}{2r_i - D_w} \right) \right]^{0,41} \right\}^{10/3} \right)^{3/10} \quad (21)$$

For the outer ring or housing washer,  $Q_{ce}$  can be calculated using the basic dynamic axial load rating,  $C_a$

$$Q_{ce} = \frac{C_a}{Z \sin \alpha} \left( 1 + \left\{ \left( \frac{1-\gamma}{1+\gamma} \right)^{1,72} \left[ \frac{r_i}{r_e} \left( \frac{2r_e - D_w}{2r_i - D_w} \right) \right]^{0,41} \right\}^{-10/3} \right)^{3/10} \quad (22)$$

#### 4.3.1.4 Thrust ball bearings with a nominal contact angle, $\alpha = 90^\circ$

For the shaft washer,  $Q_{ci}$  can be calculated using the basic dynamic axial load rating,  $C_a$

$$Q_{ci} = \frac{C_a}{Z} \left( 1 + \left\{ \left[ \frac{r_i}{r_e} \left( \frac{2r_e - D_w}{2r_i - D_w} \right) \right]^{0,41} \right\}^{10/3} \right)^{3/10} \quad (23)$$

For the housing washer,  $Q_{ce}$  can be calculated using the basic dynamic axial load rating,  $C_a$

$$Q_{ce} = \frac{C_a}{Z} \left( 1 + \left\{ \left[ \frac{r_i}{r_e} \left( \frac{2r_e - D_w}{2r_i - D_w} \right) \right]^{0,41} \right\}^{-10/3} \right)^{3/10} \quad (24)$$

#### 4.3.2 Dynamic equivalent rolling element load

The dynamic equivalent rolling element load for an inner ring or a shaft washer,  $Q_{ei}$ , which is rotating relative to the bearing load is

$$Q_{ei} = \left( \frac{1}{Z} \sum_{j=1}^Z Q_j^3 \right)^{1/3} \quad (25)$$

and for an inner ring or a shaft washer which is stationary relative to the bearing load is

$$Q_{ei} = \left( \frac{1}{Z} \sum_{j=1}^Z Q_j^{10/3} \right)^{3/10} \quad (26)$$

The dynamic equivalent rolling element load for an outer ring or a housing washer,  $Q_{ee}$ , which is stationary relative to the bearing load is

$$Q_{ee} = \left( \frac{1}{Z} \sum_{j=1}^Z Q_j^{10/3} \right)^{3/10} \quad (27)$$

and for an outer ring or a housing washer which is rotating relative to the bearing load is

$$Q_{ee} = \left( \frac{1}{Z} \sum_{j=1}^Z Q_j^3 \right)^{1/3} \quad (28)$$

For a normal load distribution, the difference between the dynamic equivalent rolling element loads for a rotating and a stationary inner ring is less than 2%. This can generally be neglected, especially as the

deviation of dynamic equivalent rolling element loads on inner ring and outer ring partially compensate each other.

When calculations are carried out, the inner ring is generally considered to be rotating and the outer ring to be stationary.

#### 4.3.3 Basic reference rating life

Using the rolling element load for the basic dynamic load ratings and the dynamic equivalent rolling element loads, the basic reference rating life,  $L_{10r}$ , can be calculated.

$$L_{10r} = \left[ \left( \frac{Q_{ci}}{Q_{ei}} \right)^{-10/3} + \left( \frac{Q_{ce}}{Q_{ee}} \right)^{-10/3} \right]^{-9/10} \quad (29)$$

#### 4.3.4 Dynamic equivalent reference load

The dynamic equivalent reference load for radial ball bearings,  $P_{ref,r}$ , is

$$P_{ref,r} = \frac{C_r}{L_{10r}^{1/3}} \quad (30)$$

and for thrust (axial) ball bearings,  $P_{ref,a}$

$$P_{ref,a} = \frac{C_a}{L_{10r}^{1/3}} \quad (31)$$

#### 4.3.5 Modified reference rating life

The modified reference rating life,  $L_{nmr}$ , for radial ball bearings is calculated by means of the life modification factor,  $a_{ISO}$ , which can be calculated using ISO 281:2007, Equations (31) to (33).

$$L_{nmr} = a_1 a_{ISO} \left( \frac{C_r}{P_{ref,r}} \right)^3 \quad (32)$$

For thrust ball bearings, the modified reference rating life calculation is

$$L_{nmr} = a_1 a_{ISO} \left( \frac{C_a}{P_{ref,a}} \right)^3 \quad (33)$$

with the life modification factor  $a_{ISO}$  calculated using ISO 281:2007, Equations (37) to (39).

## 5 Roller bearings

### 5.1 General

This clause describes the analysis of the internal load distribution for radial roller bearings under radial load, taking into account radial clearance and tilt. Calculation methods concerning the analysis of bearings of different geometry or for more complex load cases can be derived from the equations given in this Technical Specification.

The bearing internal load distribution is calculated for a static equilibrium, dynamic effects like centripetal and gyroscopic forces are considered insignificant. This assumption is generally valid for low and moderate speeds. At high speed, centripetal and gyroscopic forces can become predominant and significantly alter the bearing internal load distribution.

**5.2 Bearing internal load distribution**

**5.2.1 Elastic deflection of line contact**

According to Reference [4], the elastic deflection of a rolling element with line contact can be described by the equation

$$Q = c_L \delta^{10/9} \tag{34}$$

with the spring constant,  $c_L$ , for contacting parts made of steel

$$c_L = 35\,948 L_{we}^{8/9} \tag{35}$$

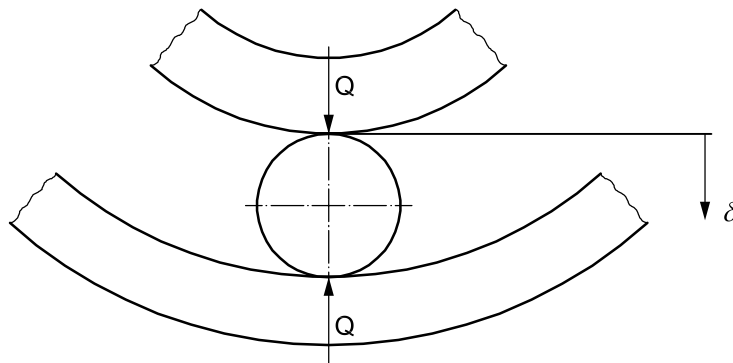

**Figure 2 — Total deflection of roller contacts**

**5.2.2 Lamina model**

For the case where the raceways are cylindrical, the elastic deflection of a misaligned rolling element can be described by a lamina model.

To calculate the elastic deflection, the roller is divided into  $n_s$  identical laminae, see Figure 3. The number of laminae shall be at least  $n_s = 30$ .

The load-deflection equation, giving the load on lamina  $k$  of roller  $j$ ,  $q_{j,k}$ , is

$$q_{j,k} = c_s \delta_{j,k}^{10/9} \tag{36}$$

with the spring constant,  $c_s$

$$c_s = \frac{35\,948 L_{we}^{8/9}}{n_s} \tag{37}$$



For a radial deflection,  $\delta_r$ , of the inner ring, the elastic deflection of the rolling element  $j$ ,  $\delta_j$ , is

$$\delta_j = \delta_r \cos \varphi_j - \frac{s}{2} \quad (38)$$

The total misalignment angle between the raceways in the plane, shown in Figure 4, of the rolling element  $j$ ,  $\psi_j$ , is given by

$$\psi_j = \arctan(\tan \psi \cos \varphi_j) \quad (39)$$

This leads to the elastic deflection of the lamina  $k$  of the rolling element  $j$ ,  $\delta_{j,k}$

$$\delta_{j,k} = \langle \delta_j - x_k \tan \psi_j \rangle \quad (40)$$

The right-hand side of Equation (40) is set to zero if it is negative.

NOTE The assumptions in Equation (40) are not exactly true when influences of rib load and different inner ring and outer ring profiles exist.

Further, the profile depth is subtracted from the deflection

$$\delta_{j,k} = \langle \delta_j - x_k \tan \psi_j - 2P(x_k) \rangle \quad (41)$$

The right-hand side of Equation (41) is set to zero if it is negative.

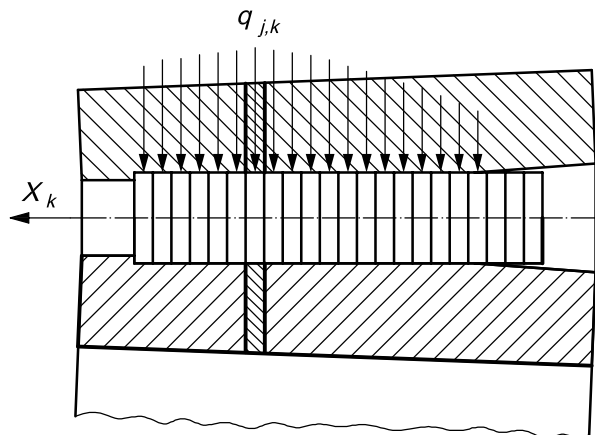

Figure 3 — Lamina model

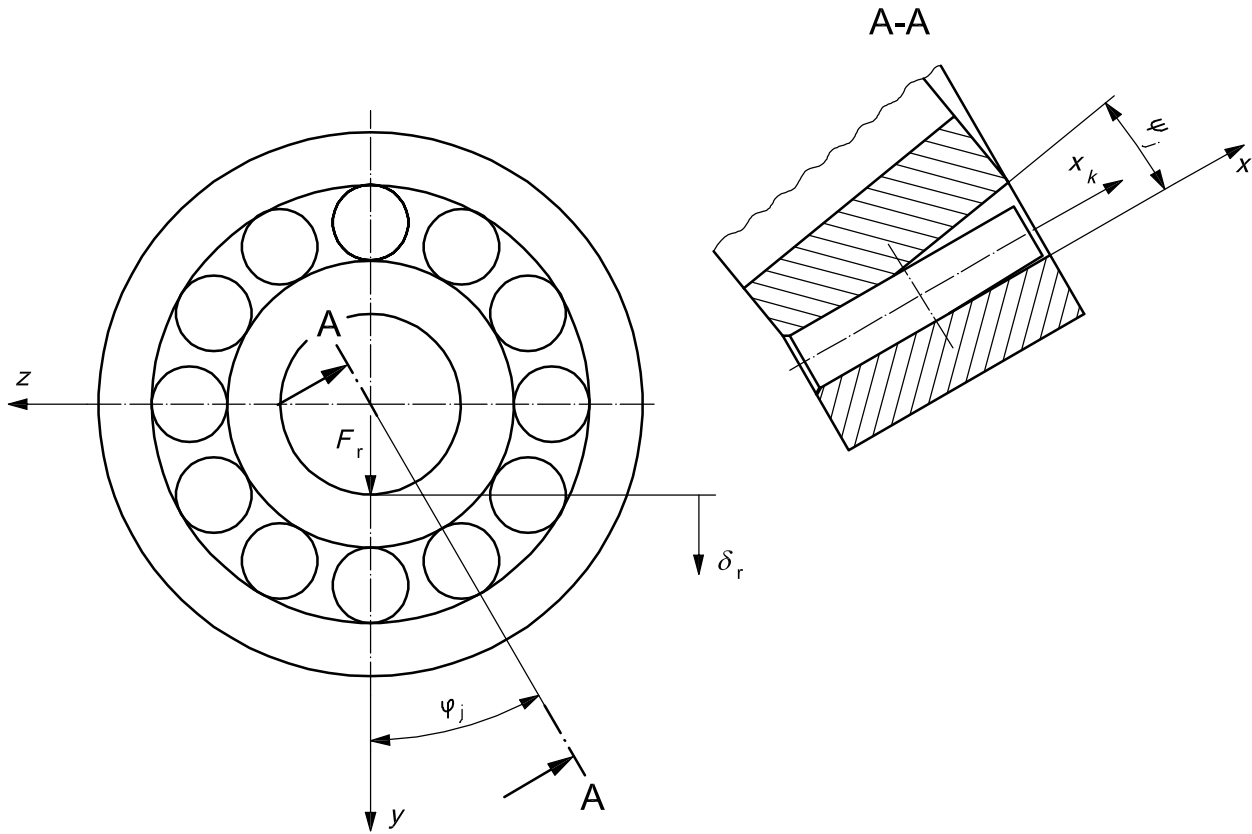

Figure 4 — Misaligned roller bearing

5.2.3 Roller profile

If a purely cylindrical roller is loaded, edge stresses will occur, which can substantially exceed the calculated Hertzian pressure. Therefore rollers are usually profiled.

For rollers made of steel and usual applications, the profile functions,  $P(x_k)$ , of Equations (42) to (44) have been derived.

For rollers having a length,  $L_{we} \leq 2,5D_{we}$

$$P(x_k) = 0,00035D_{we} \ln \left[ \frac{1}{1 - (2x_k / L_{we})^2} \right] \tag{42}$$

For rollers having a length,  $L_{we} > 2,5D_{we}$ , a stepwise defined profile function applies

$$P(x_k) = 0 \quad \text{for } |x_k| \leq \frac{L_{we} - 2,5D_{we}}{2} \tag{43}$$

$$P(x_k) = 0,00050D_{we} \ln \left( \frac{1}{1 - \left\{ \left[ 2|x_k| - (L_{we} - 2,5D_{we}) \right] / 2,5D_{we} \right\}^2} \right) \quad \text{for } |x_k| > \frac{L_{we} - 2,5D_{we}}{2} \tag{44}$$

The profile functions in Equations (42) to (44) give approximate values. Actual roller designs, based on the expertise of the manufacturer, can deviate significantly from these reference geometries.

## 5.2.4 Static equilibrium

The static equilibrium conditions for the external forces and moment acting on the bearing rings and the reaction forces of the rolling elements yield the equation system, which can be solved by iteration, of 5.2.4.1 and 5.2.4.2.

### 5.2.4.1 Sum of all forces

$$F_r - \frac{c_L}{n_s} \sum_{j=1}^Z \left( \cos \varphi_j \sum_{k=1}^{n_s} \delta_{j,k}^{10/9} \right) = 0 \quad (45)$$

### 5.2.4.2 Sum of all moments

$$M_z - \frac{c_L}{n_s} \sum_{j=1}^Z \left( \cos \varphi_j \sum_{k=1}^{n_s} x_k \delta_{j,k}^{10/9} \right) = 0 \quad (46)$$

## 5.3 Rating life

### 5.3.1 Rolling element load for the basic dynamic load rating

#### 5.3.1.1 General

The rolling element load for the basic dynamic load ratings for inner rings,  $Q_{ci}$  and  $Q_{ce}$ , are derived from ISO/TR 1281-1 [1].

#### 5.3.1.2 Radial roller bearing

The rolling element load for the basic dynamic load ratings for inner rings,  $Q_{ci}$ , and outer rings,  $Q_{ce}$ , can be calculated using the basic dynamic radial load rating,  $C_r$ , for single-row and multi-row bearings.

$$Q_{ci} = \frac{1}{\lambda_v} \frac{C_r}{0,378 Z (\cos \alpha) i^{7/9}} \left\{ 1 + \left[ 1,038 \left( \frac{1-\gamma}{1+\gamma} \right)^{143/108} \right]^{9/2} \right\}^{2/9} \quad (47)$$

$$Q_{ce} = \frac{1}{\lambda_v} \frac{C_r}{0,364 Z (\cos \alpha) i^{7/9}} \left\{ 1 + \left[ 1,038 \left( \frac{1-\gamma}{1+\gamma} \right)^{143/108} \right]^{-9/2} \right\}^{2/9} \quad (48)$$

with

$$\lambda_v = 0,83 \quad (49)$$

according to Reference [1].

This value of  $\lambda_v$  requires a detailed analysis of the contact stress as described in References [5], [6] or [7], or by applying the approximate function for the stress concentration in Equation (60).

**5.3.1.3 Thrust roller bearing with a nominal contact angle,  $\alpha \neq 90^\circ$**

The rolling element load for the basic dynamic load ratings for inner rings or shaft washers,  $Q_{ci}$ , and outer rings or housing washers,  $Q_{ce}$ , can be calculated using the basic dynamic axial load rating,  $C_a$ .

$$Q_{ci} = \frac{1}{\lambda v} \frac{C_a}{Z \sin \alpha} \left\{ 1 + \left[ \left( \frac{1-\gamma}{1+\gamma} \right)^{143/108} \right]^{9/2} \right\}^{2/9} \quad (50)$$

$$Q_{ce} = \frac{1}{\lambda v} \frac{C_a}{Z \sin \alpha} \left\{ 1 + \left[ \left( \frac{1-\gamma}{1+\gamma} \right)^{143/108} \right]^{-9/2} \right\}^{2/9} \quad (51)$$

with

$$\lambda v = 0,73 \quad (52)$$

This value of  $\lambda v$  requires a detailed analysis of the contact stress as described in References [5], [6] or [7], or by applying the approximate function for the stress concentration in Equation (60).

**5.3.1.4 Thrust roller bearing with a nominal contact angle,  $\alpha = 90^\circ$**

The rolling element load for the basic dynamic load ratings for shaft washers,  $Q_{ci}$ , and housing washers,  $Q_{ce}$ , can be calculated using the basic dynamic axial load rating,  $C_a$ .

$$Q_{ci} = \frac{1}{\lambda v} \frac{C_a}{Z} \times 2^{2/9} \quad (53)$$

$$Q_{ce} = \frac{1}{\lambda v} \frac{C_a}{Z} \times 2^{2/9} \quad (54)$$

with

$$\lambda v = 0,73 \quad (55)$$

This value of  $\lambda v$  requires a detailed analysis of the contact stress as described in References [5], [6] or [7], or by applying the approximate function for the stress concentration in Equation (60).

**5.3.2 Basic dynamic load rating of a bearing lamina**

The basic dynamic load rating of a bearing lamina of the inner ring,  $q_{ci}$ , is

$$q_{ci} = Q_{ci} \left( \frac{1}{n_s} \right)^{7/9} \quad (56)$$

The basic dynamic load rating of a bearing lamina of the outer ring,  $q_{ce}$ , is

$$q_{ce} = Q_{ce} \left( \frac{1}{n_s} \right)^{7/9} \quad (57)$$

### 5.3.3 Concentration of edge stress

In cases where the rolling elements are only lightly profiled or severely misaligned, edge stresses can arise which need to be taken into account in the rating life calculation. The distribution of contact stress over the length of the rolling elements can be calculated by means of References [5], [6] or [7]. From the calculated distribution of the contact stress over the roller length, an approximated function of the stress concentration at the inner ring raceway,  $f_i[j,k]$ , can be obtained from Equation (58) and at the outer ring raceway,  $f_e[j,k]$ , from Equation (59).

$$f_i[j,k] = \left[ \left( \frac{p_{Hi,j,k}}{271} \right)^2 D_{we} (1 - \gamma) \frac{L_{we}}{n_s} \right] / q_{j,k} \quad (58)$$

$$f_e[j,k] = \left( \frac{p_{He,j,k}}{271} \right)^2 D_{we} (1 + \gamma) \frac{L_{we}}{n_s} / q_{j,k} \quad (59)$$

As a first approximation, a stress riser function,  $f[k]$ , determined from contact stress calculations, can be used for the lamina  $k$

$$f_i[k] = f_e[k] = 1 - \left[ 0,01 / \ln \left( 1,985 \left| \frac{2k - n_s - 1}{2n_s - 2} \right| \right) \right] \quad (60)$$

This approximation function is only valid for an approximated profile obtained with the aid of the Equations (42), (43) and (44), and providing the conditions of medium load and a total misalignment of the bearing of less than 4' are fulfilled. For a general calculation, the use of the methods described in References [5], [6] or [7] is recommended.

### 5.3.4 Dynamic equivalent load on a lamina

The dynamic equivalent load on a lamina  $k$  of an inner ring,  $q_{kei}$ , which is rotating relative to the load is

$$q_{kei} = \left[ \frac{1}{Z} \sum_{j=1}^Z (f_i[j,k] q_{j,k})^4 \right]^{1/4} \quad (61)$$

and the dynamic equivalent load on a lamina  $k$  of an inner ring,  $q_{kei}$ , which is stationary relative to the load is

$$q_{kei} = \left[ \frac{1}{Z} \sum_{j=1}^Z (f_i[j,k] q_{j,k})^{4,5} \right]^{1/4,5} \quad (62)$$

The dynamic equivalent load on a lamina  $k$  of an outer ring,  $q_{kee}$ , which is stationary relative to the load is

$$q_{kee} = \left[ \frac{1}{Z} \sum_{j=1}^Z (f_e[j,k] q_{j,k})^{4,5} \right]^{1/4,5} \quad (63)$$

and the dynamic equivalent load on a lamina  $k$  of an outer ring,  $q_{kee}$ , which is rotating relative to the load is

$$q_{kee} = \left[ \frac{1}{Z} \sum_{j=1}^Z (f_e[j,k] q_{j,k})^4 \right]^{1/4} \quad (64)$$

For a normal load distribution, the difference between the dynamic equivalent rolling element loads for a rotating and a stationary inner ring is less than 2 %. This can generally be neglected, especially as the deviation of dynamic equivalent rolling element loads on inner ring and outer ring partially compensate each other.

When calculations are carried out, the inner ring is generally considered to be rotating and the outer ring to be stationary.

### 5.3.5 Basic reference rating life

The basic reference rating life,  $L_{10r}$ , is

$$L_{10r} = \left\{ \sum_{k=1}^{n_s} \left[ \left( \frac{q_{kci}}{q_{kei}} \right)^{-4,5} + \left( \frac{q_{kce}}{q_{kee}} \right)^{-4,5} \right] \right\}^{-8/9} \quad (65)$$

### 5.3.6 Dynamic equivalent reference load

The dynamic equivalent reference load for radial roller bearings,  $P_{ref,r}$ , is

$$P_{ref,r} = \frac{C_r}{L_{10r}^{3/10}} \quad (66)$$

and for thrust roller bearings,  $P_{ref,a}$ , is

$$P_{ref,a} = \frac{C_a}{L_{10r}^{3/10}} \quad (67)$$

### 5.3.7 Modified reference rating life

For radial roller bearings, the modified reference rating life,  $L_{nmr}$ , is

$$L_{nmr} = a_1 \left( \sum_{k=1}^{n_s} \left\{ a_{ISO} \left( \frac{e_C C_{ur}}{P_{ks}} \kappa \right) \right\}^{-9/8} \left[ \left( \frac{q_{kci}}{q_{kei}} \right)^{-9/2} + \left( \frac{q_{kce}}{q_{kee}} \right)^{-9/2} \right] \right)^{-8/9} \quad (68)$$

with the life modification factor,  $a_{ISO}$ , calculated using ISO 281:2007, Equations (34) to (36).

The dynamic equivalent load,  $P_{ks}$ , of the bearing lamina  $k$  is

$$P_{ks} = 0,323 Z (\cos \alpha) n_s \left\{ \left[ q_{kei}^{9/2} + \left( 1,038 \frac{q_{ci}}{q_{ce}} \right)^{9/2} q_{kee}^{9/2} \right] / \left[ 1 + \left( 1,038 \frac{q_{ci}}{q_{ce}} \right)^{9/2} \right] \right\}^{2/9} \quad (69)$$

For thrust roller bearings, the modified reference rating life is

$$L_{nmr} = a_1 \left( \sum_{k=1}^{n_s} \left\{ a_{ISO} \left( \frac{e_C C_{ua}}{P_{ks}} \kappa \right) \right\}^{-9/8} \left[ \left( \frac{q_{kci}}{q_{kei}} \right)^{-9/2} + \left( \frac{q_{kce}}{q_{kee}} \right)^{-9/2} \right] \right)^{-8/9} \quad (70)$$

with the life modification factor,  $a_{ISO}$ , calculated using ISO 281:2007, Equations (40) to (42).

The dynamic equivalent load,  $P_{kS}$ , of the bearing lamina  $k$  is

$$P_{kS} = Z (\sin \alpha) n_s \left( \frac{q_{kei}^{9/2} + q_{kee}^{9/2}}{2} \right)^{2/9} \quad (71)$$

## 6 Reference geometries

### 6.1 General

From the calculation methods for radial ball bearings and radial roller bearings presented in this Technical Specification, calculation methods for bearings with more complex designs can be derived. Reference geometries for the most common bearing design types are defined here.

The geometry data given here are approximate values. Actual bearing designs, based on the expertise of the manufacturer, can deviate from these reference geometries.

### 6.2 Cylindrical roller bearings and needle roller bearings

The roller profile is defined in Equations (42), (43) and (44).

### 6.3 Deep groove ball bearings, angular contact ball bearings and separable ball bearings

Cross-sectional raceway groove radius of outer ring,  $r_e$ :

$$r_e = 0,53D_w \quad (72)$$

Cross-sectional raceway groove radius of inner ring,  $r_i$ :

$$r_i = 0,52D_w \quad (73)$$

### 6.4 Spherical roller bearings

Cross-sectional spherical raceway radius of outer ring,  $r_e$ :

$$r_e = \frac{D_{pw}}{2 \cos \alpha} + \frac{D_{we}}{2} \quad (74)$$

Cross-sectional raceway radius of inner ring,  $r_i$ :

$$r_i = r_e \quad (75)$$

Convex curvature radius of rolling elements,  $R_p$ :

$$R_p = 0,97r_e \quad (76)$$

### 6.5 Tapered roller bearings

Profile of tapered rollers:  $P(x_k) = 0,000\,45 D_{we} \ln \left[ \frac{1}{1 - (2x_k/L_{we})^2} \right]$  (77)

## 6.6 Self-aligning ball bearings

$$\text{Cross-sectional spherical raceway radius of outer ring: } r_e = 0,5 \left( 1 + \frac{1}{\gamma} \right) D_w \quad (78)$$

$$\text{Cross-sectional raceway groove radius of inner ring: } r_i = 0,53 D_w \quad (79)$$

## 6.7 Thrust cylindrical roller bearings and thrust needle roller bearings

The roller profile is defined in Equations (42), (43) and (44).

## 6.8 Thrust ball bearings and thrust angular contact ball bearings

$$\text{Cross-sectional raceway groove radius of housing washer: } r_e = 0,54 D_w \quad (80)$$

$$\text{Cross-sectional raceway groove radius of shaft washer: } r_i = 0,54 D_w \quad (81)$$

## 6.9 Thrust spherical roller bearings

$$\text{Cross-sectional spherical raceway radius of housing washer: } r_e = \frac{D_{pw} + D_{we} \cos 45^\circ}{2 \cos \alpha} \quad (82)$$

$$\text{Cross-sectional raceway radius of shaft washer: } r_i = r_e \quad (83)$$

$$\text{Convex curvature radius of rolling elements: } R_p = 0,97 r_e \quad (84)$$

## 6.10 Thrust tapered roller bearings

$$\text{Profile of tapered rollers, } P(x_k): P(x_k) = 0,000\ 45 D_{we} \ln \left[ \frac{1}{1 - (2x_k/L_{we})^2} \right] \quad (85)$$

## 7 Life modification factor, $a_{ISO}$ , and contamination factor, $e_C$

### 7.1 General

When the lubricant is contaminated with solid particles permanent indentations in the raceway can be generated when these particles are overrolled. At these indentations, local stress risers are generated, which lead to reduced life of the rolling bearing. This life reduction due to contamination in the lubricant film is taken into account by the contamination factor,  $e_C$ , described in ISO 281.

### 7.2 Life modification factor

The contamination factor is included in the equations for calculating the life modification factor,  $a_{ISO}$ . Equations for calculating the factor,  $a_{ISO}$ , are given in ISO 281. Advice on the selection of suitable equations from ISO 281, for different bearing types, is specified in 4.3.5 and 5.3.7.



### 7.3 Contamination factor

The background to the contamination factor,  $e_C$ , is described in ISO 281:2007, 9.3 and the equations needed for estimating its size can be found in ISO 281:2007, Annex A. The following lubrication systems are considered:

- circulating oil lubrication with on-line filters;
- oil bath lubrication and circulating oil with off-line filters only;
- grease lubrication.

## 8 Fatigue load limit and basic dynamic load rating

Equations for calculating the bearing fatigue load limit,  $C_U$ , and the basic dynamic load rating,  $C_r$  or  $C_a$ , are given in ISO 281. For accurate calculations, knowledge of the internal design of the bearings is needed, and it is therefore recommended that fatigue load limits and basic dynamic load ratings are selected from the bearing manufacturers' catalogues.

## Bibliography

- [1] ISO/TR 1281-1, *Rolling bearings — Explanatory notes on ISO 281 — Part 1: Basic dynamic load rating and basic rating life*
- [2] HARRIS, T.A. *Rolling bearing analysis*, 4th edition. Wiley, New York, 2001. 1086 p.
- [3] BREUER, M. *Theoretische und experimentelle Bestimmung der Wälzlagersteifigkeit* [Theoretical and experimental determination of rolling bearing rigidity]. VDI, Düsseldorf, 1994. 127 p. (*Fortschritt-Berichte Reihe 1: Konstruktionstechnik, Maschinenelemente*, No. 241.)
- [4] PALMGREN, A. *Grundlagen der Wälzlagertechnik* [Fundamentals of rolling bearing technology], 3rd edition. Franckh, Stuttgart, 1964. 264 p.
- [5] REUSNER, H. *Druckflächenbelastung und Oberflächenverschiebung im Wälzkontakt von Rotationskörpern* [Pressure area load and surface shift in the rolling contact of rotating bodies]. Thesis, Karlsruhe University, 1977. 144 p.
- [6] DE MUL, J.M., KALKER, J.J., FREDRIKSSON, R. The contact between arbitrary curved bodies of finite dimension. *Trans. ASME J. Tribol.* 1986, **108**, pp. 140-148
- [7] HARTNETT, M.J. A general numerical solution for elastic body contact problems. In: CHENG, H.S., KEER, L.M., editors. *Solid contact and lubrication*, pp. 51-66. ASME, New York, NY, 1980. (*Applied Mechanics Division*, Vol. 39.)

Copyright International Organization for Standardization

© ISO 2008. All rights reserved.

---

---

**ICS 21.100.20**

Price based on 20 pages