

---

---

**Petroleum and related products —  
Determination of spray ignition  
characteristics of fire-resistant fluids —**

**Part 2:  
Spray test — Stabilized flame heat  
release method**

*Produits pétroliers et produits connexes — Détermination  
des caractéristiques d'inflammation des fluides difficilement  
inflammables en jet pulvérisé —*

*Partie 2: Essai de pulvérisation — Méthode par dégagement de  
chaleur d'une flamme stabilisée*





**COPYRIGHT PROTECTED DOCUMENT**

© ISO 2012

All rights reserved. Unless otherwise specified, no part of this publication may be reproduced or utilized in any form or by any means, electronic or mechanical, including photocopying and microfilm, without permission in writing from either ISO at the address below or ISO's member body in the country of the requester.

ISO copyright office  
Case postale 56 • CH-1211 Geneva 20  
Tel. + 41 22 749 01 11  
Fax + 41 22 749 09 47  
E-mail [copyright@iso.org](mailto:copyright@iso.org)  
Web [www.iso.org](http://www.iso.org)

Published in Switzerland

# Contents

	Page
<b>Foreword</b> .....	<b>iv</b>
<b>1 Scope</b> .....	<b>1</b>
<b>2 Normative references</b> .....	<b>1</b>
<b>3 Terms and definitions</b> .....	<b>1</b>
<b>4 Principle</b> .....	<b>2</b>
<b>5 Reagents and materials</b> .....	<b>2</b>
<b>6 Apparatus</b> .....	<b>2</b>
6.1 Test installation.....	2
6.2 Instrumentation.....	7
<b>7 Sampling and sample preparation</b> .....	<b>9</b>
<b>8 Apparatus preparation</b> .....	<b>10</b>
<b>9 Procedure</b> .....	<b>10</b>
9.1 Measurements at a propane flow rate of 0,13 Nm <sup>3</sup> /h.....	10
9.2 Measurements at a propane flow rate of 0,4 Nm <sup>3</sup> /h.....	11
9.3 Rejection of test data.....	11
9.4 Tabulation of measurements.....	12
9.5 Number of tests.....	12
<b>10 Calculations</b> .....	<b>13</b>
10.1 Ignitability factor.....	13
10.2 Flame length index.....	14
10.3 Smoke density.....	14
<b>11 Expression of results</b> .....	<b>14</b>
11.1 Individual results.....	14
11.2 Ranking system.....	14
<b>12 Precision</b> .....	<b>15</b>
<b>13 Test report</b> .....	<b>15</b>
<b>Annex A (normative) Verification of propane pressure and flow rate</b> .....	<b>16</b>
<b>Annex B (normative) Verification of propane flame characteristics</b> .....	<b>17</b>
<b>Annex C (normative) Test apparatus calibration</b> .....	<b>22</b>
<b>Annex D (informative) Suggested fire-resistant classification scheme</b> .....	<b>24</b>
<b>Annex E (informative) Example pro-forma for test results</b> .....	<b>25</b>
<b>Bibliography</b> .....	<b>28</b>

## Foreword

ISO (the International Organization for Standardization) is a worldwide federation of national standards bodies (ISO member bodies). The work of preparing International Standards is normally carried out through ISO technical committees. Each member body interested in a subject for which a technical committee has been established has the right to be represented on that committee. International organizations, governmental and non-governmental, in liaison with ISO, also take part in the work. ISO collaborates closely with the International Electrotechnical Commission (IEC) on all matters of electrotechnical standardization.

International Standards are drafted in accordance with the rules given in the ISO/IEC Directives, Part 2.

The main task of technical committees is to prepare International Standards. Draft International Standards adopted by the technical committees are circulated to the member bodies for voting. Publication as an International Standard requires approval by at least 75 % of the member bodies casting a vote.

In other circumstances, particularly when there is an urgent market requirement for such documents, a technical committee may decide to publish other types of document:

- an ISO Publicly Available Specification (ISO/PAS) represents an agreement between technical experts in an ISO working group and is accepted for publication if it is approved by more than 50 % of the members of the parent committee casting a vote;
- an ISO Technical Specification (ISO/TS) represents an agreement between the members of a technical committee and is accepted for publication if it is approved by 2/3 of the members of the committee casting a vote.

An ISO/PAS or ISO/TS is reviewed after three years in order to decide whether it will be confirmed for a further three years, revised to become an International Standard, or withdrawn. If the ISO/PAS or ISO/TS is confirmed, it is reviewed again after a further three years, at which time it must either be transformed into an International Standard or be withdrawn.

Attention is drawn to the possibility that some of the elements of this document may be the subject of patent rights. ISO shall not be held responsible for identifying any or all such patent rights.

ISO/TS 15029-2 was prepared by Technical Committee ISO/TC 28, *Petroleum products and lubricants*.

ISO/TS 15029 consists of the following parts, under the general title *Petroleum and related products — Determination of spray ignition characteristics of fire-resistant fluids*:

- *Part 1: Spray flame persistence — Hollow-cone nozzle method*
- *Part 2: Spray test — Stabilized flame heat release method* [Technical Specification]

# Petroleum and related products — Determination of spray ignition characteristics of fire-resistant fluids —

## Part 2: Spray test — Stabilized flame heat release method

**WARNING** — The use of this part of ISO 15029 may involve hazardous materials, operations and equipment. This part of ISO 15029 does not purport to address all of the safety problems associated with its use. It is the responsibility of the user of this part of ISO 15029 to establish appropriate safety and health practices and determine the applicability of regulatory limitations prior to use.

### 1 Scope

This part of ISO 15029 specifies a method by which the fire hazards of pressurized sprays of fire-resistant fluids can be compared. Two sizes of propane flame are used to ignite and stabilize combustion of an air-atomised release of fluid and measurements related to the rate of heat release, length of flame and density of smoke are taken to give quantitative information on the fire behaviour of the fluid.

### 2 Normative references

The following referenced documents are indispensable for the application of this document. For dated references, only the edition cited applies. For undated references, the latest edition of the referenced document (including any amendments) applies.

ISO 3170:2004, *Petroleum liquids — Manual sampling*

ISO 3696:1987, *Water for analytical laboratory use — Specification and test methods*

ISO 6743-4:1999, *Lubricants, industrial oils and related products (class L) — Classification — Part 4: Family H (Hydraulic systems)*

ISO 9162:—<sup>1)</sup>, *Petroleum products — Fuels (class F) — Liquefied petroleum gases — Specifications*

IEC 60584-1:1995, *Thermocouples — Part 1: Reference tables*

### 3 Terms and definitions

For the purposes of this document, the following terms and definitions apply.

#### 3.1

##### **stabilised spray flame**

point at which the rate of energy release, flame length and other combustion properties, are steady as a function of time, so that sensible time-averaged values can be calculated

#### 3.2

##### **flame length**

distance in millimetres from the vertical centre line of the gas burner to the furthest downstream point reached by the visible flame

1) To be published (revision of ISO 9162:1989).

### 3.3

#### **flame length index**

function of the flame length and propane flow rate

### 3.4

#### **ignitability factor**

corrected value, to the nearest integer, of a function of heat release at a specific propane flow rate

### 3.5

#### **smoke density**

smoke density, as a function of smoke opacity in the flue pipe before and after introduction of the test fluid

NOTE See ISO 5659-2:2012, term 3.8 "optical density of smoke".

## 4 Principle

A pre-conditioned flux of the test fluid is delivered to a test chamber through a twin-fluid atomiser. Compressed air, supplied to the nozzle at a controlled rate, is used to produce an atomised spray, which is exposed to a defined flame of a gas burner present throughout the test. The gas flame acts to produce, by input of heat at a steady rate, a stabilized spray flame (3.1), so that combustion properties, such as the rate of energy release and flame length, (3.2) are sufficiently steady over time to allow time-averaged values to be measured.

Temperatures are measured both at the entry to the combustion chamber and in the exhaust, with the burner operating first without, and then with, release of the test fluid. The flame length (3.2) and smoke opacity of the exhaust are also measured. Calculations of functions, such as flame length index (3.3) ignitability factor (3.4) and smoke density (3.5) are made from these measurements. Sampling of the exhaust can enable the production rate of other combustion products to be determined. A grading system for the performance of fire-resistant fluids is developed from these determinations and calculations.

## 5 Reagents and materials

5.1 **Propane**, high purity (minimum 98 %) grade, generally conforming to the requirements of ISO 9162.

5.2 **Nitrogen**, oxygen-free, commercial grade.

5.3 **Compressed air**.

5.4 **Water**, conforming to the requirements of grade 3 of ISO 3696.

5.5 **Ethylene glycol**, laboratory grade (mono, 98 % purity).

## 6 Apparatus

### 6.1 Test installation

#### 6.1.1 General

The major components of the installation are described in 6.1.2 to 6.1.6.

Figure 1 gives a general layout of the test installation.

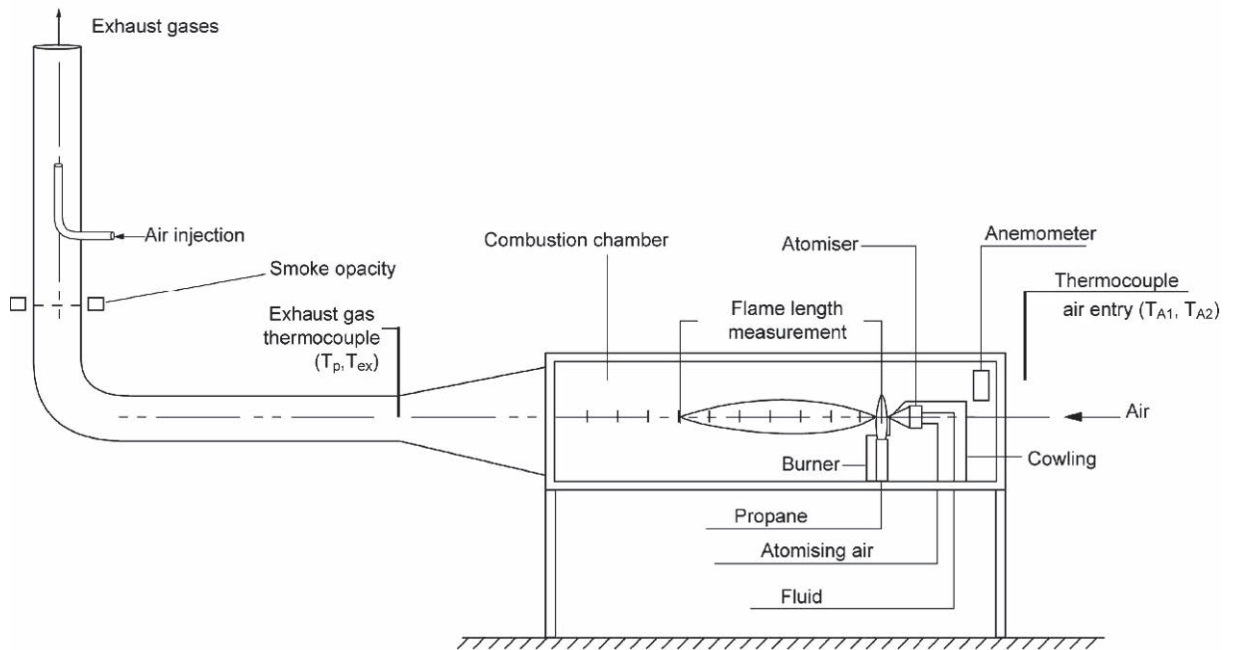

Figure 1 — General view of installation

Figure 2 shows a schematic diagram of a suggested layout of the test equipment detailing the different input streams to the combustion chamber and exhaust duct.

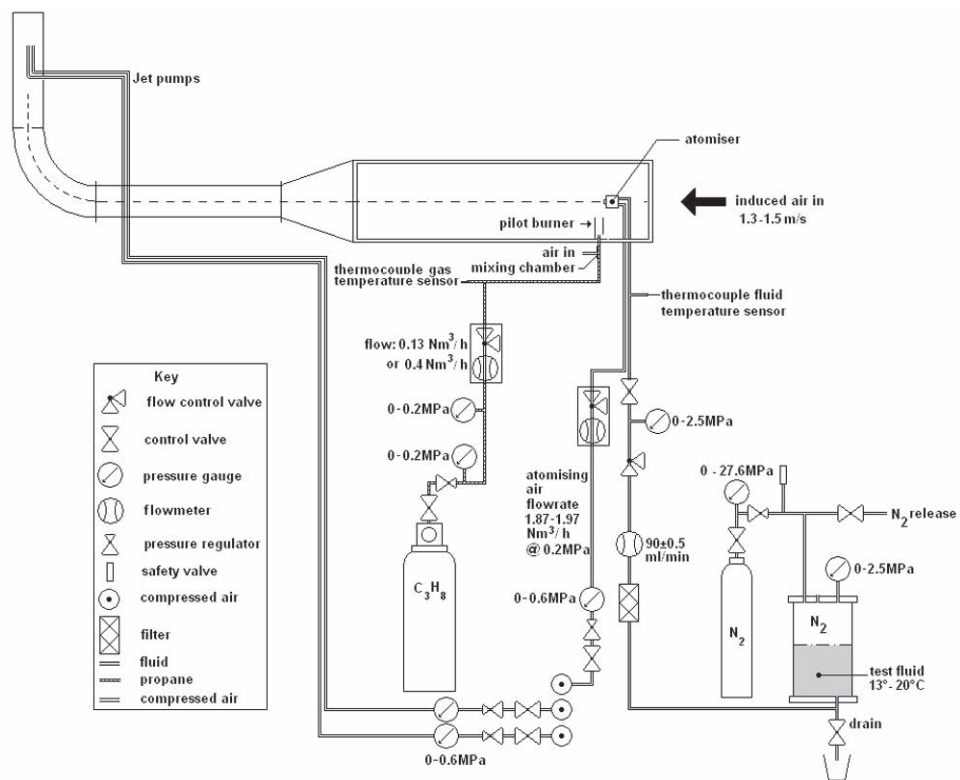

Figure 2 — Schematic diagram of suggested test rig layout

### 6.1.2 Combustion chamber

This shall be fabricated from steel sheet, 8 mm thick, of square cross-section with internal dimensions of  $(2\ 000 \pm 5)$  mm x  $(490 \pm 5)$  mm x  $(490 \pm 5)$  mm. The inner and outer surfaces shall be painted with black heat-resistant paint. A clear window of heat-resistant glass, 8,5 mm thick, shall be located in one side of the chamber. The glass shall be  $(1\ 920 \pm 10)$  mm x  $(525 \pm 10)$  mm providing an open area of the window of  $(1\ 880 \pm 10)$  mm x  $(480 \pm 10)$  mm. The window is hinged from below to allow access to the chamber. The window shall be clamped shut during use and sealed with mineral fibre tape to avoid ingress of air (See Figure 3).

### 6.1.3 Extraction system

The combustion chamber exit shall be connected to a contraction fabricated from steel sheet 1 mm thick, providing a transition from the square to a circular cross-section with an internal diameter of  $250\text{ mm} \pm 4\text{ mm}$ . This contraction,  $750\text{ mm} \pm 10\text{ mm}$  long, is connected to a horizontal section of flue pipe  $1\ 400\text{ mm} \pm 10\text{ mm}$  in length which, in turn, may be connected to further exhaust ducting or clearing system that shall be designed to provide stable conditions in the combustion chamber during a test.

The air flow through the chamber is produced by a jet pump mounted in the exhaust duct, producing an air velocity of  $1,4\text{ m/s} \pm 0,1\text{ m/s}$  measured  $50\text{ mm} \pm 2\text{ mm}$  inside the combustion chamber inlet. The temperature of the air entering the chamber shall be sufficiently constant within the range  $10\text{ }^{\circ}\text{C}$  to  $25\text{ }^{\circ}\text{C}$ , such that the temperature variation over a period of 30 s shall not exceed  $1\text{ }^{\circ}\text{C}$ . The relative humidity of the air shall lie between 40 % and 80 %.

### 6.1.4 Spray delivery system

**6.1.4.1 Reservoir.** The test fluid shall be contained in a steel reservoir of minimum capacity 3 l, designed for an internal pressure of 2,5 MPa at  $20\text{ }^{\circ}\text{C}$ . The flow of fluid from the reservoir is provided by means of pressurized nitrogen (5.2) supplied to the upper part of the reservoir, with a valve situated in the nitrogen supply pipe. Means shall be provided to permit complete drainage of the system.

**6.1.4.2 Test fluid delivery.** The fluid volume flow rate can be measured with a suitable flowmeter and controlled to  $90 \pm 0,5\text{ ml/min}$  by means of a needle valve. The fluid temperature is maintained between  $10\text{ }^{\circ}\text{C}$  and  $25\text{ }^{\circ}\text{C}$ , and measured by a thermocouple located immediately before the fluid nozzle. The fluid is delivered to the atomiser<sup>2)</sup> through nylon and/or steel piping with an internal diameter of  $7,5\text{ mm} \pm 2,5\text{ mm}$ , rated at 2 MPa and the flowmeter shall be located  $350\text{ mm} \pm 150\text{ mm}$  downstream of the valve.

**6.1.4.3 Compressed air.** Compressed air shall be supplied, via a suitable mesh filter to remove droplets and particulates at a steady flow rate of  $1,92\text{ Nm}^3/\text{h} \pm 0,05\text{ Nm}^3/\text{h}$  at a pressure of 0,2 MPa. The flow rate shall be measured by a variable area flowmeter having a flow range of  $0,4\text{ Nm}^3/\text{h}$  to  $3,0\text{ Nm}^3/\text{h}$ , located  $3\ 500\text{ mm} \pm 500\text{ mm}$  before the spray jet at a pressure of 0,2 MPa, and controlled by a valve installed downstream of the flowmeter. The temperature of the atomising air shall be between  $10\text{ }^{\circ}\text{C}$  and  $25\text{ }^{\circ}\text{C}$ .

---

2) Type 1/4JBC-12B, manufactured by Spraying Systems Co. (<http://www.spray.com>) and supplied by CT Limited, Guildford, Surrey, UK is an example of a suitable product available commercially. This information is given for the convenience of users of this part of ISO 15029 and does not constitute an endorsement by ISO of this product.



Dimensions in millimetres

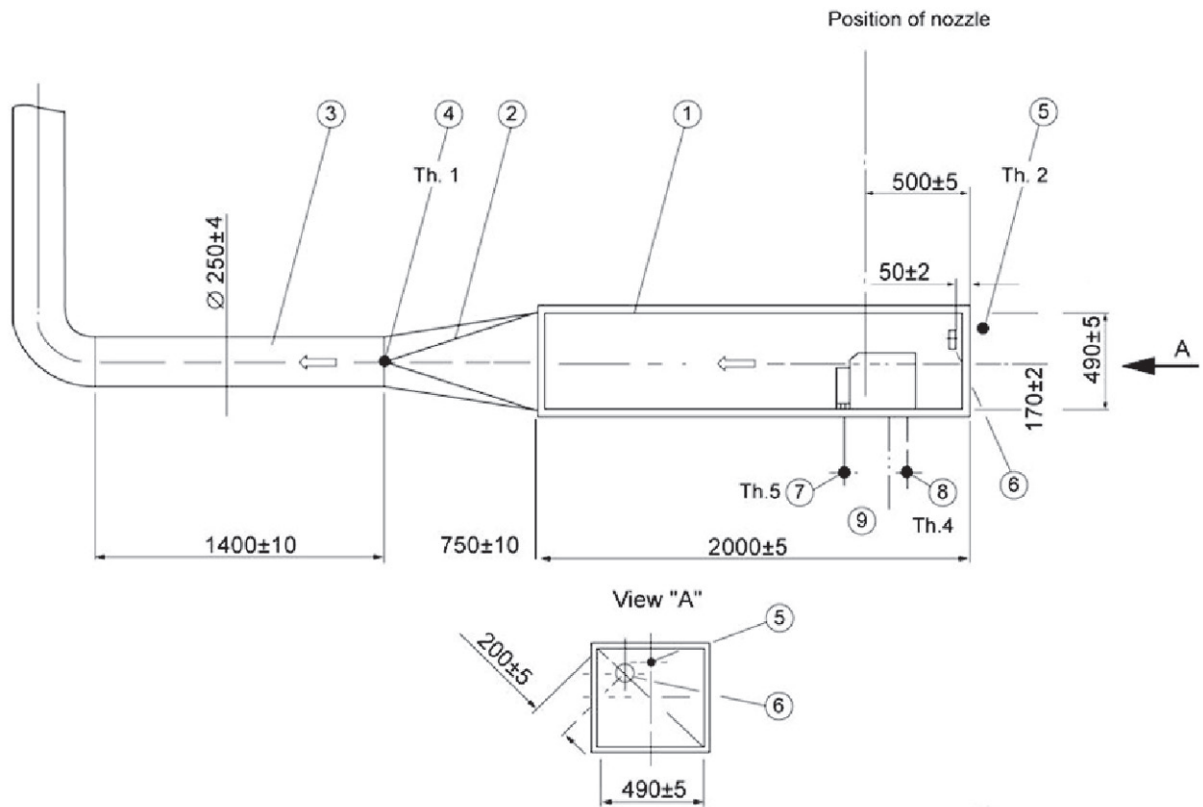

**Key**

- |   |                          |   |                            |
|---|--------------------------|---|----------------------------|
| 1 | combustion chamber       | 6 | anemometer                 |
| 2 | contraction              | 7 | propane gas thermocouple   |
| 3 | flue pipe                | 8 | atomizing air thermocouple |
| 4 | exhaust gas thermocouple | 9 | fluid inlet pipe           |
| 5 | ambient air thermocouple |   |                            |

**Figure 3 — Combustion chamber and exhaust system**

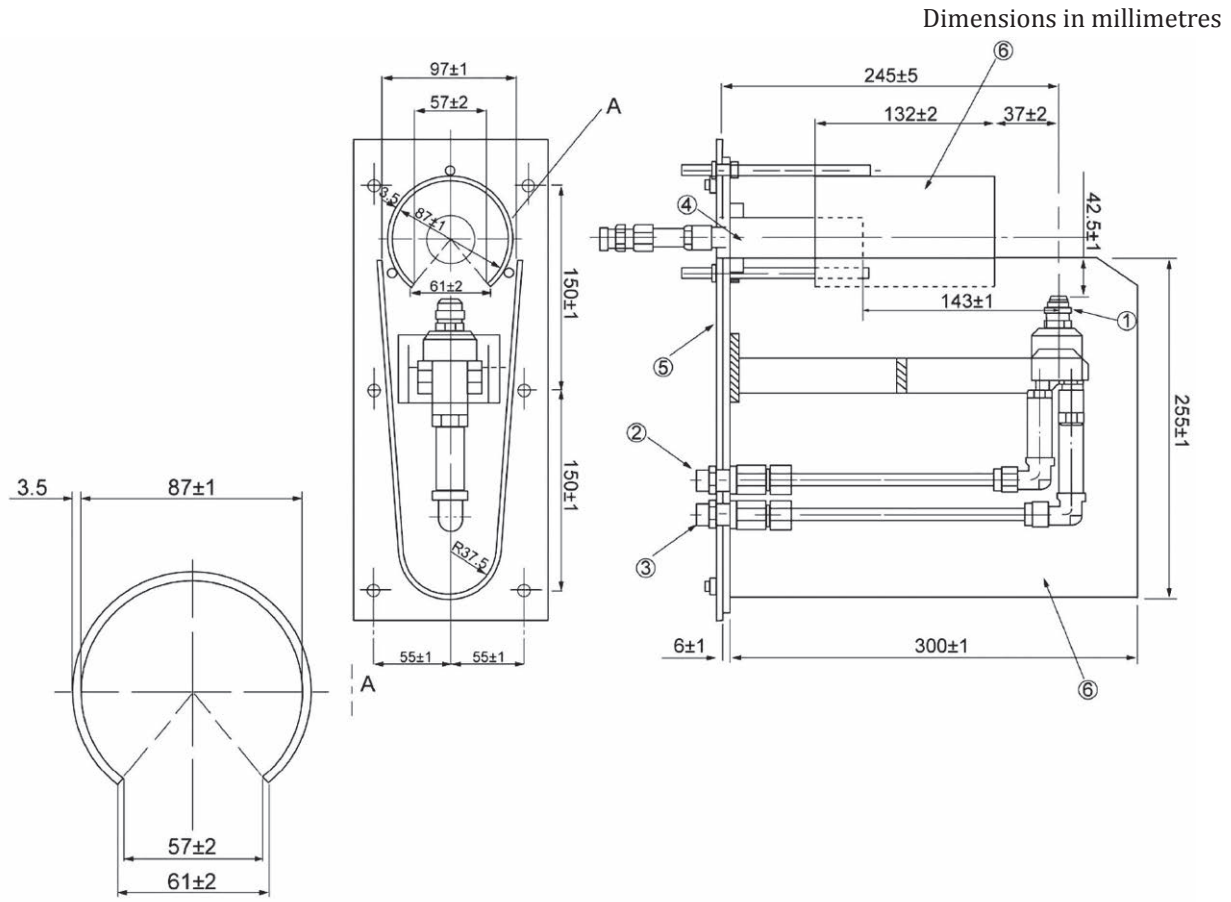

**Key**

- |   |              |   |                |
|---|--------------|---|----------------|
| 1 | spray nozzle | 4 | propane burner |
| 2 | fluid supply | 5 | base plate     |
| 3 | air supply   | 6 | cowling        |

**Figure 4 — Atomizer and burner system**

**6.1.5 Burner system**

**6.1.5.1 System design.** The gas burner, constructed of brass and illustrated in Figure 4, provides a continuous ignition source using propane (5.1) pre-mixed with air (5.3). It incorporates a nozzle<sup>3)</sup>, drilled to a diameter of 0,68 mm, and two mixing chambers, the whole mounted rigidly on to a steel base plate of 6 mm thickness (see Figure 4). The exit of the 26 mm internal diameter mixing chamber shall be 143 mm  $\pm$  1 mm below the centre line of the atomiser, and a distance of 42,5 mm  $\pm$  1 mm downstream of the atomiser orifice. If required, the burner can be manufactured from the illustration given in Figure 5.

Propane, at a minimum pressure of 0,25 MPa, shall be supplied through 4 000 mm  $\pm$  1 000 mm of flexible tubing of 6 mm  $\pm$  2 mm bore, to an assembly of a pressure gauge, flowmeter and valve. Further flexible and/or metal tubing, 2 500 mm  $\pm$  500 mm in length and of a minimum bore of 6 mm, is installed between the valve in the assembly and the gas burner.

3) Type t1700 fine flame gas nozzle, supplied by Applications des Gaz, Paris, France (now part of the Coleman Group; <http://www.coleman-eur.com>) is an example of a suitable product available commercially. This information is given for the convenience of users of this part of ISO 15029 and does not constitute endorsement by ISO of this product.

At a controlled pressure of 0,2 MPa, the propane flow rate shall be either 0,13 Nm<sup>3</sup>/h ± 0,005 Nm<sup>3</sup>/h, or 0,40 Nm<sup>3</sup>/h ± 0,005 Nm<sup>3</sup>/h, depending upon specific test requirements. The flow rate shall be measured with a variable area flowmeter having a range of 0,10 Nm<sup>3</sup>/h to 0,50 Nm<sup>3</sup>/h and of suitable resolution. The temperature of the propane on entering the burner shall be between 10 °C and 25 °C.

**6.1.5.2 System verification.** On installation the system shall be verified for conformity to the standard design. Annexes A and B describe protocols for checking the control systems and flame characteristics, respectively. At intervals of 12 months, or if it is suspected that the characteristics of the burner have changed, the burner may be checked by sampling the flame temperature at a few selected locations and comparing the measurements with the standard values given in Annex B.

## 6.1.6 Burner and atomiser mounting

**6.1.6.1 Mounting.** The atomiser and burner assembly, on the steel base plate, is protected by a cowling fabricated from 1 mm thick sheet steel bent into the form shown in Figure 4, with a height of 300 mm ± 1 mm, overall width of 97 mm ± 1 mm, and overall length of 255 mm ± 1 mm. The burner shall also be protected from the surrounding air flow by a cylindrical cowling of 87 mm ± 1 mm diameter, containing a vertical slot with an external opening of 61 mm ± 2 mm on its upstream face. Three threaded supports provide a means of elevation of this cowling, with its upper part at a distance of 37 mm ± 2 mm from the horizontal plane passing through the atomiser axis.

**6.1.6.2 Placement.** The base plate is positioned on the floor of the combustion chamber with the atomiser orifice 500 mm ± 5 mm downstream of the combustion chamber inlet orifice. Connections through the base plate and combustion chamber floor shall be provided for the supply of air, propane and test fluid to the burner and atomiser as appropriate.

## 6.2 Instrumentation

### 6.2.1 Temperature sensors

Five T-type Cu-CuNi thermocouples with an outer diameter of 1,5 mm, conforming to the requirements of IEC 60584-1, or temperature measurement devices of equivalent precision and accuracy, are positioned as illustrated in Figure 2. The third thermocouple is positioned in the test fluid reservoir with at least 50 mm of sheath completely immersed in the fluid, and not in contact with the vessel wall. All the thermocouples shall be used with 0 °C reference junctions in accordance with IEC 60584-1. Measurement accuracy shall be ± 0,5 °C over the range 15 °C to 200 °C, and the temperature resolution shall be 0,1 °C.

The accuracy of the test result is highly dependent upon the accurate positioning of the exhaust gas thermocouple. This shall be located with an accuracy of ± 0,5 mm and checked before the commencement of each new series of tests.

Where a computer is used, both this and the data acquisition system shall be capable of calculating averages of at least 100 values of each temperature measured over 120 s.

### 6.2.2 Anemometer

The air flow velocity in the combustion chamber is measured using a rotating vane anemometer with a vane diameter of 95 mm ± 30 mm located as illustrated in Figure 2 (including section "A").<sup>4)</sup>

### 6.2.3 Humidity sensors

The relative humidity of the incoming air used in each test series shall be measured and recorded at the beginning and end of each day of testing.

4) A suitable instrument is manufactured by Testo Limited. This information is given for the convenience of users of this part of ISO 15029 and does not constitute an endorsement by ISO. Equivalent products may be used if they can be shown to lead to the same results.

6.2.4 Flame length scale

A linear scale of at least 1 m in length, with a resolution of no greater than 10 mm, shall be attached to the combustion chamber side window.

Dimensions in millimetres

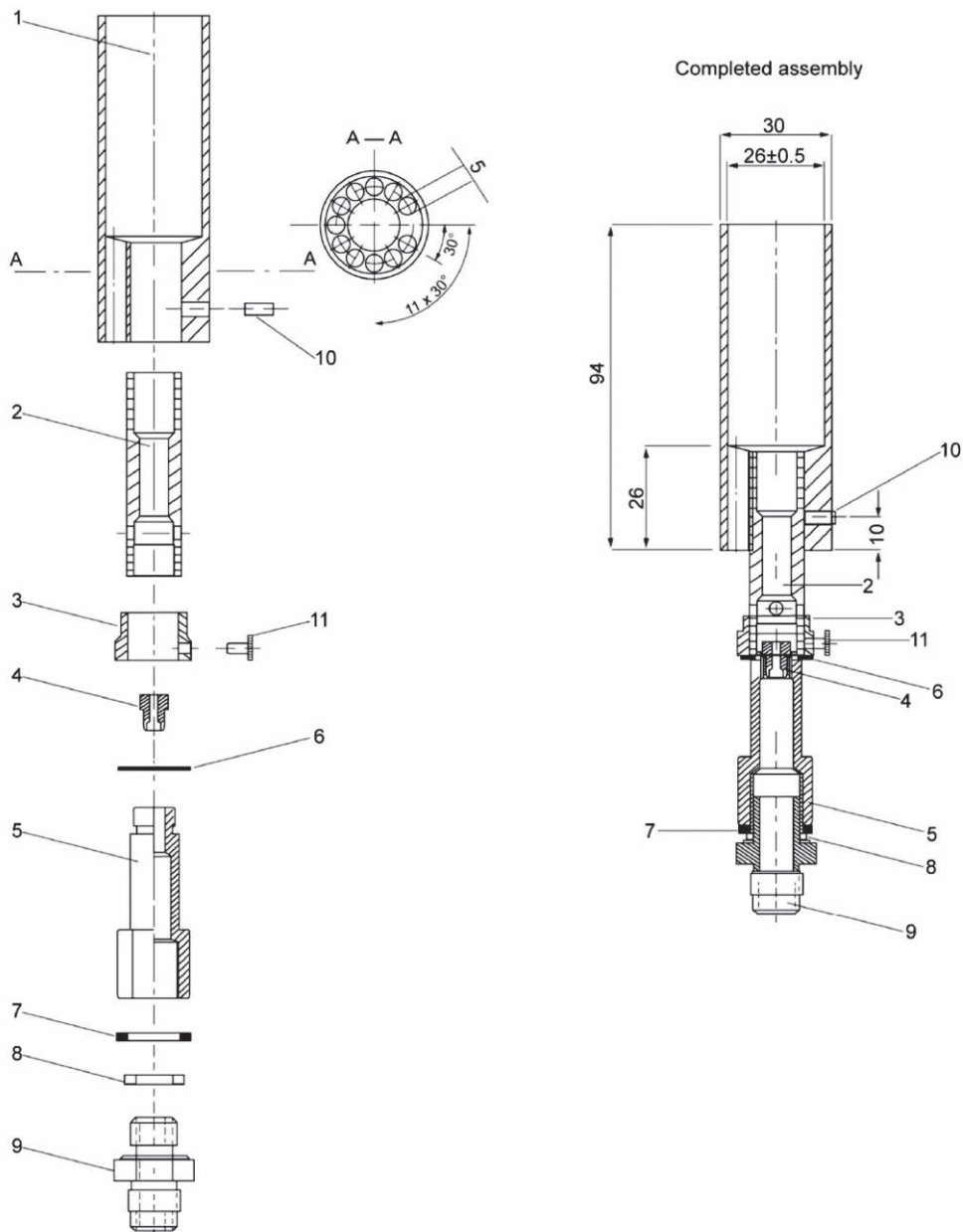

<b>Key</b>			
1	mixing chamber 1	5	nozzle holder with flash-back unit
2	mixing chamber 2	6	washer
3	regulation collar	7	washer
4	burner nozzle	8	sealing ring
		9	straight male adaptor
		10	locking screw
		11	locking screw

Figure 5 — Propane burner

### 6.2.5 Smoke meter

A white light obscuration smoke opacity meter, using an illuminated beam of  $20 \text{ mm} \pm 5 \text{ mm}$  diameter, is mounted  $625 \text{ mm} \pm 125 \text{ mm}$  downstream of the contraction in the flue pipe. The arrangement shall not reduce light transmission by soot deposits by more than 5 %. A suitable instrument is manufactured by Fire Testing Technology Limited.

### 6.2.6 Calibration of instruments

**6.2.6.1 Temperature sensors.** All the temperature sensors shall have current calibration certificates traceable to a national standard and appropriate corrections shall be applied to observed readings.

**6.2.6.2 Smoke meter.** The output of the smoke meter shall be calibrated before and after using at least three neutral density filters inserted in the light beam, giving 25 %, 50 % and 75 % light obscuration use. Observed readings shall be corrected for deviations in linearity.

**6.2.6.3 Other meters.** Flowmeters and the anemometer shall be calibrated according to the manufacturer's recommendations or at least annually by means traceable to a national standard, and the appropriate corrections made to observed readings.

**6.2.6.4 Humidity sensors.** The relative humidity sensor should be calibrated according to the manufacturer's recommendations and appropriate corrections shall be applied to all observed readings.

**6.2.6.5 Test apparatus.** Prior to each new series of tests, the entire test apparatus shall be calibrated for ignitability factor by the procedure described in Annex C and corrected values used for reporting, as described in 10.1. It is important that any changes in the measured ignitability factor values obtained with the calibration fluids be investigated to ensure that the test apparatus has not been subject to modification and conforms to the requirements of this Technical Specification.

If calibration test values differ significantly from those previously obtained then the calibration of individual components (e.g. flowmeters) should be examined.

## 7 Sampling and sample preparation

**7.1** Unless otherwise specified, samples of at least 5 l shall be obtained in accordance with the procedures described in ISO 3170.

**7.2** Store samples in sealed containers at a temperature of  $10 \text{ }^{\circ}\text{C}$  to  $30 \text{ }^{\circ}\text{C}$  under clean and dry conditions. After removing a sample immediately re-seal the container to minimize any moisture loss or gain.

**7.3** Mix the sample by shaking or stirring and examine for clarity and contamination before transferring the test portion to the conditioning beaker. If phase separation and/or particulate are observed, discard the sample.

**7.4** For water-mix fluids, such as those in categories HFAE or HFAS (as classified in ISO 6743-4, prepare the concentrate with water (5.4) within 1 h of the start of the test.

## 8 Apparatus preparation

**8.1** Turn off the propane supply and thoroughly clean the apparatus in preparation for each test, in the manner described in 8.2 to 8.6.

**8.2** Remove any traces of previous sample by draining the reservoir, pipework and flowmeter by means of disconnecting orifices at the various lowest points. Re-connect these orifices.

**8.3** Flush the reservoir with 500 ml of solvent appropriate to the sample previously tested. For water-based fluids, use water. For non-aqueous fluids, use acetone.

**8.4** Open the valve in the fluid supply circuit and pressurize the reservoir with nitrogen. Allow at least 250 ml of liquid to be expelled through the atomiser. Close the valve and de-pressurize. Drain the fluid/solvent at the atomiser orifice. Repeat the procedure given in 8.2.

**8.5** Remove any further traces of solvent in the apparatus by evaporation or careful wiping with a lint-free cloth.

**8.6** Place 500 ml of the new test fluid in the reservoir and repeat the procedure given in 8.4. If the new fluid is in the same category and quality as that last tested, repeat this operation twice. If the new fluid is a different category or quality, repeat the operation at least three times.

## 9 Procedure

### 9.1 Measurements at a propane flow rate of 0,13 Nm<sup>3</sup>/h

**9.1.1** Place 1 500 ml of sample into a 2 000 ml glass beaker and heat or cool as appropriate to the test temperature (10 °C to 25 °C), stirring to maintain homogeneity.

**NOTE** When the fluid is supplied as a concentrate it should first be diluted with distilled or deionised water as recommended by the manufacturer or supplier and 1500 ml of the diluent placed in the reservoir.

**9.1.2** Pour the test portion into the reservoir of the apparatus and pressurize the reservoir to the pressure established for the specified flow rate. Pass fluid through the atomiser, without atomising air, combustion chamber air or burner propane, until at least 200 ml of fluid has been collected at the atomiser exit. Check that the flow has been steady, that there are no air bubbles in the delivery and that the fluid is free of contaminant. Initial releases will be carried out to establish the pressure required to provide the specified flow. This will normally be about 1 MPa, the flow can be adjusted using the needle valve.

**9.1.3** The fluid delivery rate at the nozzle should be checked by collecting fluid in a suitably graduated container over a measured time; the volume and time for collection taking into account the accuracy required. If necessary adjust the flow control valve until the flow rate is within the specified limits. Initial releases will be carried out to establish the pressure required to provide the specified flow. This will normally be about 1 MPa, the flow can be adjusted using the needle valve.

**9.1.4** In order to ensure test parameters are within the specified limits, measure and record fluid temperature, air inlet temperature and atmospheric humidity.

**9.1.5** Set the air flow rate through the combustion chamber to obtain an air velocity of 1,4 m/s ± 0,1 m/s. Record the value and also the ambient relative humidity.

**9.1.6** Ignite the propane burner and adjust the propane flow rate to 0,130 Nm<sup>3</sup>/h ± 0,005 Nm<sup>3</sup>/h.



**9.1.7** Adjust the atomising air to a flow rate of  $1,92 \text{ Nm}^3/\text{h} \pm 0,05 \text{ Nm}^3/\text{h}$ .

**9.1.8** Measure and record the light obscuration from the smoke meter under steady conditions before the test fluid is introduced into the chamber,  $V_0$ , as the average of at least four readings taken over a period of 60 s in 9.1.12.

**9.1.9** With the glass window of the combustion chamber closed and sealed, allow conditions to stabilize to a point at which the temperature of the exhaust gases at the chamber exit,  $T_p$ , and the temperature of the air at the chamber inlet,  $T_{A1}$ , vary by no more than  $1 \text{ }^\circ\text{C}$  over a period of 30 s. Record these values to the nearest  $0,1 \text{ }^\circ\text{C}$ , taking the average of at least four values over a 60 s period.

**9.1.10** Pass test fluid to the atomiser at the specified flow rate of  $90 \text{ ml}/\text{min} \pm 0,5 \text{ ml}/\text{min}$  and measure the new exhaust temperature,  $T_{EX}$ , at intervals of approximately 5 s, until the average of at least five values over a period of 30 s is within 2,5 % of the average of at least five values taken in a consecutive period of 30 s.

**9.1.11** With conditions steady, take measurements of the temperature at the chamber inlet,  $T_{A2}$ , and the new exhaust temperature,  $T_{EX}$ , as the average of at least 10 measurements of each taken over a period of 120 s.

**9.1.12** Measure and record the flame length,  $L_A$ , as the average of at least 10 measurements taken over a period of 120 s of steady conditions. In the case of a fluctuating flame, the length shall be the furthest distance downstream reached instantaneously.

**9.1.13** Repeat the measurement of 9.1.8 after steady conditions with test fluid flow described in 9.1.8 have been achieved and record this new value as  $V_1$ .

**9.1.14** Re-check and record the chamber air flow velocity and the ambient relative humidity

**9.1.15** Calculate the ignitability factor,  $RI$  as outlined in Clause 10.

NOTE The fluid rate can vary during the test as the equipment (and fluid) temperatures increase. It is therefore necessary to check the flow rate after every 4 determinations and, if outside the limit, then to repeat the test runs as appropriate.

## 9.2 Measurements at a propane flow rate of $0,4 \text{ Nm}^3/\text{h}$

**9.2.1** If, during a test, the fluid has been found to have an ignitability factor above 50, or a flame length of less than 100 mm, at a propane flow rate of  $0,13 \text{ Nm}^3/\text{h}$ , it is necessary to carry out the test at a higher propane flow rate and to report these results.

**9.2.2** The test conditions shall be established as indicated in 9.1.1 to 9.1.7 with the exception that the propane flow rate shall now be adjusted to  $0,400 \text{ Nm}^3/\text{h} \pm 0,005 \text{ Nm}^3/\text{h}$ .

**9.2.3** Carry out the procedure described in 9.1.8 to 9.1.13 at the new propane flow rate.

## 9.3 Rejection of test data

A test run shall be discontinued if, during the procedure, any of the test conditions is not satisfied. These are defined as follows:

- a) the temperature at the combustion chamber inlet is constant to within  $\pm 1 \text{ }^\circ\text{C}$ ;
- b) the atomising air flow rate is constant at  $1,92 \text{ Nm}^3/\text{h} \pm 0,05 \text{ Nm}^3/\text{h}$ ;
- c) the propane flow rate is constant at either  $0,130 \text{ Nm}^3/\text{h} \pm 0,005 \text{ Nm}^3/\text{h}$  or  $0,400 \text{ Nm}^3/\text{h} \pm 0,005 \text{ Nm}^3/\text{h}$ ;
- d) the test fluid flow rate is constant at  $90 \text{ ml}/\text{min} \pm 0,5 \text{ ml}/\text{min}$ ;

- e) the air velocity through the combustion chamber is constant at 1,4 m/s ± 0,1 m/s;
- f) the relative humidity of the air is 40 % to 80 %;
- g) the temperature of the test fluid is 10 °C to 25 °C;
- h) the temperature of the atomising air at the nozzle, and of the propane, is 10 °C to 25 °C.

Testing can be resumed as soon as the conditions meet the above limits.

#### 9.4 Tabulation of measurements

The relatively large number of measurements required to obtain the test results are best recorded on proforma result sheets, which may also allow space for any calculation required. Examples of proformas are given within Annex E.

#### 9.5 Number of tests

##### 9.5.1 General

The minimum number of test determinations is set upon the basis of obtaining an ignitability factor,  $RI$ , which is the most sensitive property being measured, within some defined limits of accuracy. The minimum level of accuracy set is that the average of  $N$  individual  $RI$  measurements lies within 5 % of the true mean value obtained from an infinite sample size, with 67 % confidence.

##### 9.5.2 Calculation

Assuming a normal distribution of measurements, the number of tests required to satisfy the relation specified in 9.5.1 is given by the equation:

$$400S_N^2/N RI_N \leq 1,0 \tag{1}$$

where

$N$  is the number of tests;

$RI_N$  is the average of  $N$  tests;

$S_N$  is the variance, defined by Equation (2).

$$S_N^2 = \sum (RI_i - RI_N)^2 / (N - 1) \tag{2}$$

where  $RI_i$  is the  $i$ th measurement of ignitability factor.

The percentage error,  $\delta$ , in the mean,  $RI_N$ , of  $N$  measurements of  $RI$ , is given by the equation:

$$\delta = 100S_N / RI_N N^{0,5} \tag{3}$$

Where the ignitability factor is found to be within 5 % of a grade boundary, a sufficient number of tests are required to derive a mean value of  $RI$  which is accurate to within one integer. This requires:

$$N \geq S_N^2 \tag{4}$$

Tests shall be repeated until this calculation is satisfied by repeating the procedure from 9.1.7.



### 9.5.3 Marginal values

When an average value of  $RI$ , obtained at a propane flow rate of  $0,13 \text{ Nm}^3/\text{h}$ , lies between 35 and 60, and more than  $N/2$  of these tests give individual values greater than 50, that fluid shall be re-tested at the higher propane flow rate of  $0,4 \text{ Nm}^3/\text{h}$ , and the low propane flow rate results discarded. If less than  $N/2$  tests at the low propane flow rate give individual values greater than 50, then all the values are included in the calculation of average  $RI$ . If the average of these values is greater than or equal to 50, then this fluid shall be re-tested at the higher flow rate. If a fluid, tested at the low propane flow rate, gives an average value of equal to or above 50, but re-tested at the higher propane flow rate, gives an average value of below 50, the value of  $RI$  for that fluid shall be taken as 50.

### 9.5.4 Conclusion

On the basis of the above considerations, the minimum number of tests required at a specified propane flow rate is eight.

## 10 Calculations

### 10.1 Ignitability factor

#### 10.1.1 At propane flow rate of $0,13 \text{ Nm}^3/\text{h}$

Calculate the uncorrected ignitability factor,  $RI_W$ , at the low propane flow rate from the following equation:

$$RI_W = 500(T_p - T_{A1}) / [7(T_{EX} - T_{A2})] \quad (5)$$

where

$T_p$  is the exhaust temperature without release of the test fluid, expressed in degrees Celsius;

$T_{A1}$  is the air temperature at the chamber inlet without release of the test fluid, expressed in degrees Celsius;

$T_{EX}$  is the exhaust temperature with release of the test fluid, expressed in degrees Celsius;

$T_{A2}$  is the air temperature at the chamber inlet with release of the test fluid, expressed in degrees Celsius.

Correct  $RI_W$  to obtain  $RI$  from the low propane flow rate calibration curve developed by the method described in Annex C, and in accordance with 6.2.5.4.

#### 10.1.2 At propane flow rate of $0,4 \text{ Nm}^3/\text{h}$

Calculate the uncorrected ignitability factor,  $RI_X$ , at the high propane flow rate from the following equation:

$$RI_X = [100(T_p - T_{A1}) / (T_{EX} - T_{A2})] + 30 \quad (6)$$

Correct  $RI_X$  to obtain  $RI$  from the high propane flow rate calibration curve developed by the method described in Annex C, and in accordance with 6.2.5.4.

## 10.2 Flame length index

### 10.2.1 At propane flow rate of 0,13 Nm<sup>3</sup>/h

Calculate the flame length index,  $RL_W$ , from the measured flame length at the low propane volumetric flow rate,  $L_A$ , from the following equation:

$$RL_W = 5\,000/L_A \quad (7)$$

### 10.2.2 At propane flow rate of 0,4 Nm<sup>3</sup>/h

Calculate the flame length index,  $RL_X$ , from the measured flame length at the high propane volumetric flow rate,  $L_B$ , from the following equation:

$$RL_X = (6\,250/L_B) + 37,5 \quad (8)$$

## 10.3 Smoke density

Calculate the smoke density,  $D$ , defined by the equation:

$$D = \lg(V_0/V_1) \quad (9)$$

where

$V_0$  is the light obscuration obtained from the meter before test fluid flow;

$V_1$  is the light obscuration obtained from the meter during test fluid flow.

## 11 Expression of results

### 11.1 Individual results

Round the ignitability factor,  $RI$ , and the flame length index,  $RL$ , to the nearest integer, with values of exactly 0,5 being rounded up.

Round the smoke density,  $D$ , to the nearest 0,001

Test results will be expressed as numerical values of  $RI$ ,  $RL$  and  $D$ .

### 11.2 Ranking system

The results may also be classified in terms of an alphabetical ranking scheme.

One suggested scheme is given within Annex D. This is a provisional scheme which may be modified as further test experience is obtained. In this scheme, for all parameters, "A" represents the most fire-resistant category of the property evaluated. The primary reference is the ignitability factor,  $RI$ , with flame length index,  $RL$ , and smoke density,  $D$ , being secondary factors. Thus the most fire-resistant category possible in this system is A(A/A) and the lowest fire-resistant is H(F/D).

The spray ignition characteristics may, therefore, be reported in the manner shown, with letter categories corresponding to the numerical results obtained in the tests.

## 12 Precision

No precision is yet available for this method due to the small number of test rigs in regular use. Until this situation changes, each laboratory shall report RI values along with the results for ignitability for the calibration fluids given in Table C.1.

## 13 Test report

The test report shall contain at least the following information:

- a) a reference to this Technical Specification;
- b) the type and complete identification of the product tested, including any dilution of concentrate, if appropriate;
- c) the result of the test (see Clause 11);
- d) the conditions under which each test run was carried out and any deviation, by agreement or otherwise, from the procedure specified;
- e) the date of the test.

## Annex A (normative)

### Verification of propane pressure and flow rate

#### A.1 Apparatus

##### A.1.1 Pressure gauge

A calibrated digital or analogue gauge, with a minimum range of 20 kPa to 500 kPa, and with an accuracy of  $\pm 5$  kPa or better over the range 200 kPa to 400 kPa.

##### A.1.2 Flowmeter

A calibrated flowmeter, or flowmeters, with a resolution of 0,005 Nm<sup>3</sup>/h or better over the range 0,1 Nm<sup>3</sup>/h to 0,5 Nm<sup>3</sup>/h.

The procedure is intended to check the burner. Thus the circuit comprises the propane cylinder, a regulator, a valve and a flowmeter. The circuit used in the rig for carrying out the test should not be used.

#### A.2 Procedure

##### A.2.1 Measurement

At a distance of no more than 3 m from the propane burner, and at a point beyond which there are no restrictions or sharp bends in the supply line, insert the pressure gauge (A.1.1) and immediately downstream of it, the flowmeter (A.1.2). Supply propane from a source via a variable regulator until the pressure at the gauge is steady for at least 10 s. Read the pressure and flow under steady conditions. Increase the pressure and repeat the readings. Take pressure and flow readings, and at least four pressures between 40 kPa and 200 kPa.

##### A.2.2 Verification

Table A.1 gives the standard pressure/flow curve points for propane supply. Fit the readings obtained in accordance with A.2.1 on to this curve and compare the values. For satisfactory performance, the measured flow rate shall be within  $\pm 0,01$  Nm<sup>3</sup>/h of the corresponding point on the curve.

**Table A.1 — Propane pressure and flow rate calibration curve**

<b>Gauge pressure, MPa</b>	40	50	70	100	150	200
<b>Flow rate, Nm<sup>3</sup>/h</b>	0,164	0,184	0,222	0,261	0,333	0,400

## Annex B (normative)

### Verification of propane flame characteristics

#### B.1 Apparatus

##### B.1.1 General

Figure B.1 illustrates a general view of the positioning of the thermocouple in the combustion chamber for temperature measurement of the burner flame. Measurements are carried out with the inner and outer cowlings in place, but with the front window of the combustion chamber fully open to allow access and adjustment to the traverse system.

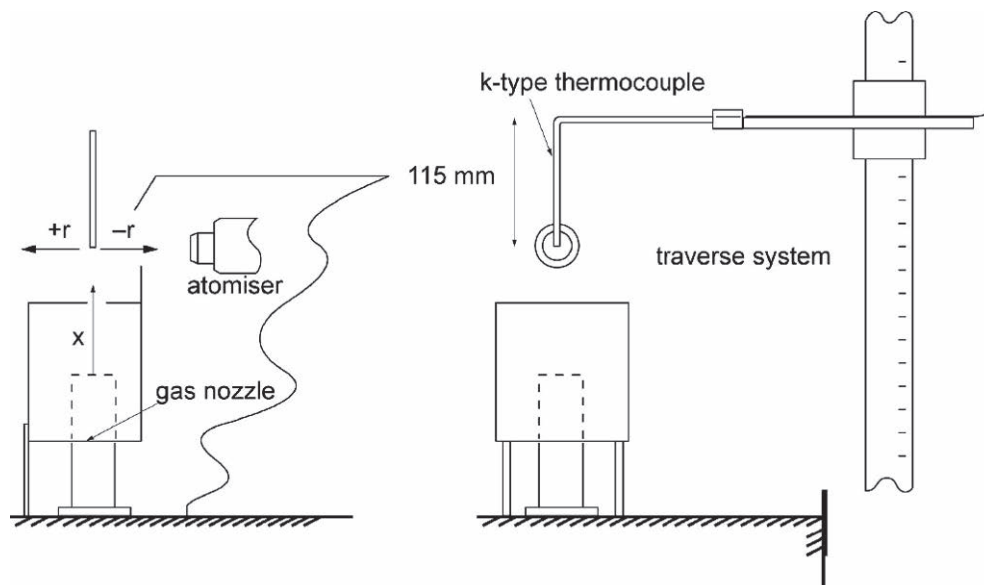

Figure B.1 — General arrangement of flame temperature measurement

##### B.1.2 Temperature sensor

K-type 3 mm stainless steel sheathed thermocouple, bent through 90° at a distance of 115 mm ± 5 mm from the sensing tip.

##### B.1.3 Traverse system

A suitable stand and clamp shall hold the thermocouple with the 115 mm straight section aligned at ± 5° to the vertical. The stand shall have both vertical and horizontal linear scales for the measurement of the spatial position of the thermocouple tip.

The accuracy of the test result is highly dependent upon the accurate positioning of the exhaust gas thermocouple. This shall be located with an accuracy of ± 0,5 mm and checked before the commencement of each new series of tests.

### B.1.4 Insulation board

A ceramic fibre insulating board, 7 mm ± 1 mm in thickness and with a minimum size of 300 mm × 300 mm, shall be fitted to the inner upper surface of the combustion chamber during testing. It shall be held in place by supports that do not interfere with the flame characteristics or the free movement of the thermocouple in the traverse system.

## B.2 Flame temperature measurements

### B.2.1 Axial temperatures

Adjust the propane flow rate to either the low (0,13 Nm<sup>3</sup>/h) or high (0,4 Nm<sup>3</sup>/h) rate and light the burner. Position the tip of the thermocouple at a distance of  $x = 0$ , corresponding to the exit orifice plane of the gas nozzle, and within ± 2 mm of the orifice centre line. Measure and record this temperature. Move the thermocouple upwards in the same vertical plane and repeat the temperature measurements at 10 mm intervals up to a distance of 200 mm above the nozzle. Repeat the procedure for the second propane flow rate.

### B.2.2 Radial temperatures

Position the thermocouple at a distance of 143 mm ± 1 mm above the gas nozzle exit orifice and traverse 40 mm in a horizontal plane towards the atomiser. Light the burner, adjust the propane flow to either the low or high rate and measure, and record the temperature. Move the thermocouple horizontally away from the atomiser and repeat the temperature measurements at 5 mm intervals across the flame width until a position of 60 mm on the other side of the flame centre line is reached. Repeat the procedure for the second propane flow rate.

## B.3 Verification

### B.3.1 Standard values

Table B.1 gives the standard values for axial and radial temperature measurements under the conditions of test. These are illustrated as curves in Figures B.2 and B.3.

### B.3.2 Conformity values

**B.3.2.1 Axial tests.** The burner shall be deemed to conform to the standard burner if, at each measurement position, the measured temperature is within ± 50 °C of the standard temperature.

**B.3.2.2 Radial tests.** The burner shall be deemed to conform to the standard burner if, at each measurement position, the measured temperature is within ± 40 °C of the standard value, within the range -30 mm to 30 mm for the low propane flow rate, and -40 mm to 50 mm for the high propane flow rate.

Table B.1 — Propane burner temperature distribution

Axial direction		
Distance from burner exit mm	Temperature at low propane flow rate °C	Temperature at high propane flow rate °C
0	861	550
10	869	568
20	871	567
30	874	580
40	872	611
50	864	629
60	866	675
70	861	718
80	860	762
90	858	817
100	852	852
110	862	880
120	870	905
130	884	927
140	890	938
150	891	946
160	904	960
170	901	971
180	888	977
190	875	980
200	854	988
210	802	994
220	796	996

Table B.2 — Propane burner temperature distribution

Radial direction		
Distance from burner centre line mm	Temperature at low propane flow rate °C	Temperature at high propane flow rate °C
-40	88	310
-35	95	435
-30	125	540
-25	228	718
-20	430	820
-15	570	948
-10	800	975
-5	900	986
0	905	970
5	900	950
10	920	970
15	820	1 006
20	650	1 000
25	460	918
30	273	778
35	145	593
40	103	455
45	-	318
50	-	234
55	-	150
60	-	121



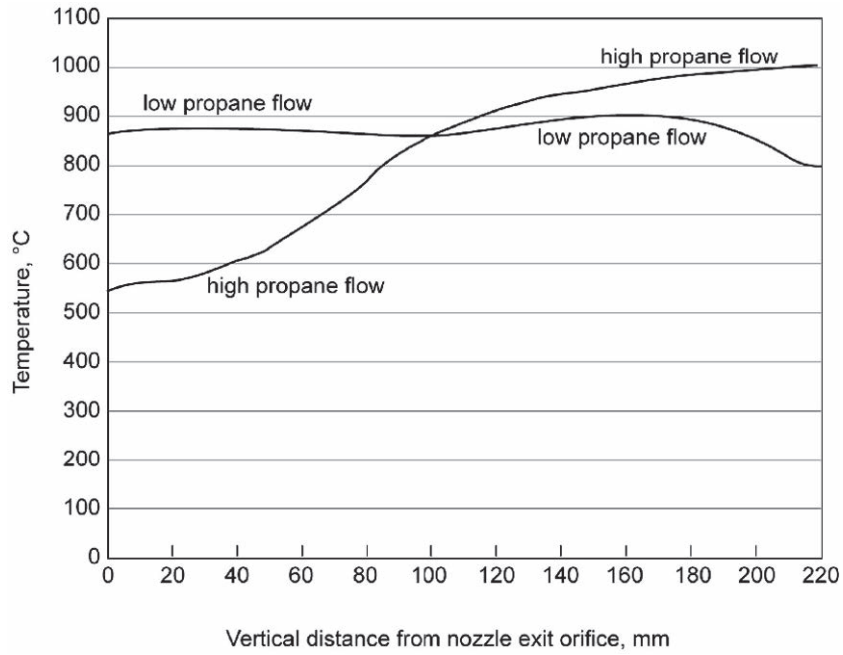

Figure B.2 — Axial temperature distribution of propane flame

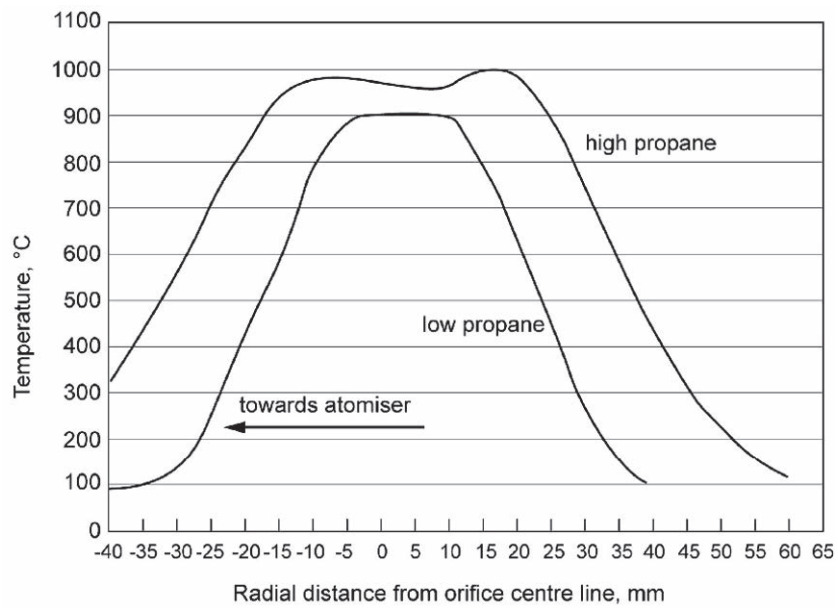

Figure B.3 — Radial temperature distribution of propane flame

## Annex C (normative)

### Test apparatus calibration

#### C.1 Calibration fluids

Prepare a series of calibration fluids (CF<sub>0</sub> to CF<sub>90</sub>) by volumetric mixing of ethylene glycol (5.5) with water (5.4). Table C.1 gives the composition of this series.

**Table C.1 — Calibration fluid composition and ignitability factor**

Fluid designation	Ethylene glycol % (V/V)	Water % (V/V)	Standard ignitability factor
CF <sub>0</sub>	100	0	17,1
CF <sub>15</sub>	85	15	23,8
CF <sub>20</sub>	80	20	34,2
CF <sub>25</sub>	75	25	45,6
CF <sub>30</sub>	70	30	59,7
CF <sub>40</sub>	60	40	64,0
CF <sub>45</sub>	55	45	71,8
CF <sub>50</sub>	50	50	81,0
CF <sub>60</sub>	40	60	90,8
CF <sub>75</sub>	25	75	108,5
CF <sub>90</sub>	10	90	125,0

NOTE For the purposes of this part of ISO 15029, “% (V/V)” is used to represent the volume fraction of a material.

#### C.2 Testing

Carry out the procedure given in 9.1 at the low propane flow rate on fluids CF<sub>0</sub>, CF<sub>15</sub>, CF<sub>20</sub> and CF<sub>25</sub>, and the procedure given in 9.2 at the high propane flow rate for the other fluids in the series, omitting the measurements of flame length and smoke density. Calculate the average uncorrected ignitability factor ( $RI_W$  or  $RI_X$ ) on each fluid from a minimum of eight tests. Further tests shall be carried out if the accuracy does not conform to within 5 % of the mean value (see 9.5). Irrespective of the actual measured value of ignitability factor, do not re-test the fluids at the other propane flow rate. Table C.1 gives “standard” ignitability factor values for each calibration fluid.

#### C.3 Calibration

For the measured ignitability factors,  $RI_W$  for the low propane flow rate and  $RI_X$  for the high propane flow rate, solve the quadratic equations below to obtain factors  $a$ ,  $b$ ,  $c$ ,  $d$  and  $e$ , using a least-squares fit to obtain the mean values. Plot these mean values against the standard values given in Table C.1.

$$\text{For low propane flow rate and } RI < 50: \quad RI = aRI_W + bRI_W^2$$

$$\text{For high propane flow rate and } RI \geq 50: \quad RI = c + dRI_X + eRI_X^2$$

Use the values of  $a$ ,  $b$ ,  $c$ ,  $d$  and  $e$  to correct all measured values of ignitability factor obtained on test samples in the same apparatus under constant operating conditions. Figure C.1 gives an illustration of a typical calibration curve.

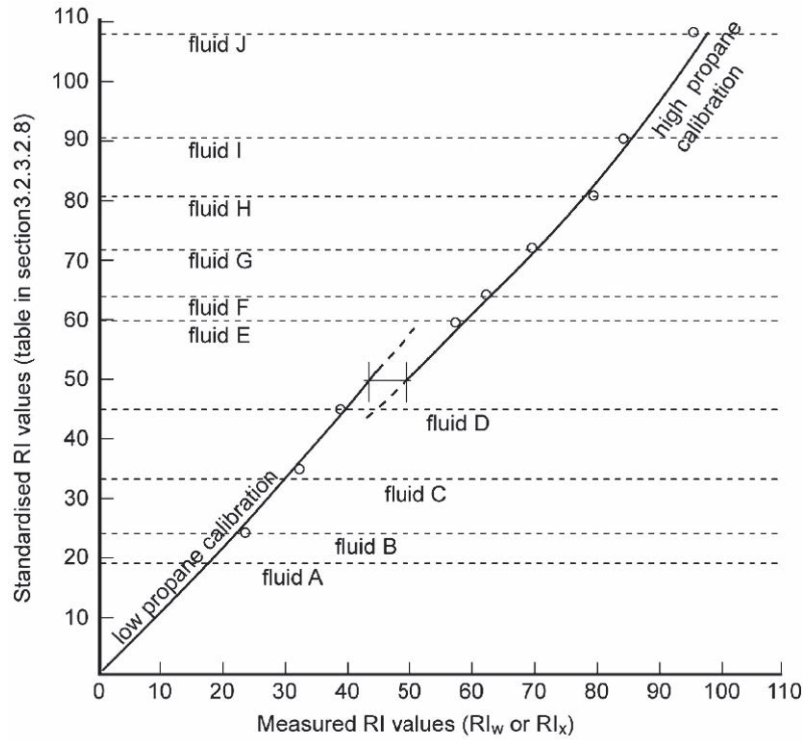

Figure C.1 — Illustration of calibration curve

## Annex D (informative)

### Suggested fire-resistant classification scheme

Category	A	B	C	D	E	F	G	H
<b>Ignitability factor, <i>RI</i></b>	> 100	100 to 80	79 to 65	64 to 50	49 to 36	35 to 25	24 to 14	≤ 13
<b>Flame length index, <i>RL</i></b>	> 100	100 to 56	55 to 51	50 to 11	10 to 7	≤ 6	-	-
<b>Smoke density, <i>D</i></b>	< 0,01	0,01 to 0,05	0,051 to 0,1	> 0,1	-	-	-	-

## **Annex E** (informative)

### **Example pro-forma for test results**

#### **E.1 General**

Clauses E.2 and E.3 give example pro-forma (worksheets) for test results obtained at the low propane flow rate and high propane flow rate respectively.

**E.2 Example worksheet for low propane rate results**

Laboratory: ..... Date: ..... Operator: .....

Fluid type: ..... Fluid identification: .....

Air flow rate: a) at beginning of test: ..... b) at the end of the test: .....

Humidity: a) at beginning of test: ..... b) at the end of the test: .....

**A Stage 1: no fluid flow**

Time h/min/s	Propane flow rate [0,130 ± 0,005] m <sup>3</sup> /h	Fluid temperature [10 to 25] °C	Exhaust temperature <i>T<sub>p</sub></i> °C	Atmospheric temperature <i>T<sub>A1</sub></i> °C	Smoke opacity <i>V<sub>0</sub></i>
Average of at least four readings over 60 s			<i>T<sub>p</sub></i> =	<i>T<sub>A1</sub></i> =	<i>V<sub>0</sub></i> =

**B Stage 2: with fluid flow**

Time h/min/s	Fluid flow rate [90 ± 0,5] ml/min	Propane flow rate [0,130 ± 0,005] m <sup>3</sup> /h	Fluid temperature [10 to 25] °C	Exhaust temperature <i>T<sub>EX</sub></i> °C	Atmospheric temperature <i>T<sub>A2</sub></i> °C	Flame length <i>L<sub>A</sub></i> mm	Smoke opacity <i>V<sub>1</sub></i>
Average of at least ten readings over 120 s				<i>T<sub>EX</sub></i> =	<i>T<sub>A2</sub></i> =	<i>L<sub>A</sub></i> =	<i>V<sub>1</sub></i> =

**C Calculations**

Uncorrected ignitability factor  $RI_W = 500(T_p - T_{A1})/[7(T_{EX} - T_{A2})] = 500(-)/[7(-)] = \text{-----}$

Flame length index  $RL_A = 5\ 000/L_A = 5\ 000/ = \text{-----}$

Smoke density  $D = \lg(V_0/V_1) = \lg(/) = \text{-----}$

**E.3 Example worksheet for high propane rate results**

Laboratory: ..... Date: .....  
 Fluid type: ..... Fluid identification: .....  
 Air flow rate: a) at beginning of test: ..... b) at the end of the test: .....  
 Humidity: a) at beginning of test: ..... b) at the end of the test: .....

**A Stage 1: no fluid flow**

Time h/min/s	Propane flow rate [0,400 ± 0,005] m <sup>3</sup> /h	Fluid temperature [10 to 25] °C	Exhaust temperature $T_p$ °C	Atmospheric temperature $T_{A1}$ °C	Smoke opacity $V_0$
Average of at least four readings over 60 s			$T_p =$	$T_{A1} =$	$V_0 =$

**B Stage 2: with fluid flow**

Time h/min/s	Fluid flow rate [90 ± 0,5] ml/min	Propane flow rate [0,400 ± 0,005] m <sup>3</sup> /h	Fluid temperature [10 to 25] °C	Exhaust temperature $T_{EX}$ °C	Atmospheric temperature $T_{A2}$ °C	Flame length $L_A$ mm	Smoke opacity $V_1$
Average of at least ten readings over 120 s				$T_{EX} =$	$T_{A2} =$	$L_A =$	$V_1 =$

**C Calculations**

Uncorrected ignitability factor  $RI_X = [100(T_p - T_{A1}) / (T_{EX} - T_{A2})] + 30 = [100(-) / (-)] + 30 =$  \_\_\_\_\_  
 Flame length index  $RL_X = (6\ 250 / L_B) + 37,5 = (6\ 250 / ) + 37,5 =$  \_\_\_\_\_  
 Smoke density  $D = \lg(V_0 / V_1) = \lg(/) =$  \_\_\_\_\_







---

---

**ICS 75.080, 13.220.40**

Price based on 28 pages