**Fire tests — Calibration and use of
heat flux meters —**

**Part 2:
Primary calibration methods**

*Essais au feu — Étalonnage et utilisation des appareils de mesure du
flux thermique —*

Partie 2: Méthodes d'étalonnage primaire



Reference number
ISO 14934-2:2013(E)

© ISO 2013



COPYRIGHT PROTECTED DOCUMENT

© ISO 2013

All rights reserved. Unless otherwise specified, no part of this publication may be reproduced or utilized otherwise in any form or by any means, electronic or mechanical, including photocopying, or posting on the internet or an intranet, without prior written permission. Permission can be requested from either ISO at the address below or ISO's member body in the country of the requester.

ISO copyright office
Case postale 56 • CH-1211 Geneva 20
Tel. + 41 22 749 01 11
Fax + 41 22 749 09 47
E-mail copyright@iso.org
Web www.iso.org

Published in Switzerland

Contents

Page

Foreword	v
Introduction	vi
1 Scope	1
2 Normative references	1
3 Terms and definitions	1
4 Principles	1
4.1 General principles.....	1
4.2 Principle of the vacuum black-body cavity (VBBC) method (method 1).....	1
4.3 Principle of the spherical black-body cavity method (method 2).....	2
4.4 Principle of the variable temperature black-body (VTBB) method (method 3).....	2
5 Suitability of a gauge for calibration	2
5.1 Types of heat flux meters.....	2
5.2 Design of heat flux meters.....	3
5.3 Measuring range.....	3
5.4 Status of heat flux meter prior to calibration.....	3
6 Vacuum black-body cavity (VBBC) method (method 1)	3
6.1 Apparatus.....	3
6.2 Operating procedure.....	6
6.3 Uncertainty.....	6
7 Spherical black-body cavity method (method 2)	7
7.1 Apparatus.....	7
7.2 Operating procedure.....	11
7.3 Uncertainty.....	11
8 Variable-temperature black-body (VTBB) method (method 3)	14
8.1 Apparatus.....	14
8.2 Operating procedure.....	16
8.3 Uncertainty.....	18
9 Number of calibration levels	19
10 Expression of results	20
11 Calibration report	21
Annex A (normative) Operating procedure for vacuum black-body cavity method (VBBC) (method 1)	22
Annex B (normative) Calculating the irradiance from the vacuum black-body cavity (VBBC) to the heat flux meter	24
Annex C (informative) Examples of computer screens for calculating the irradiance from the vacuum black-body cavity (VBBC)	27
Annex D (normative) Operating procedure for spherical black-body cavity method (method 2)	29
Annex E (normative) Calculating the irradiance from the spherical black-body cavity to the heat flux meter	31
Annex F (normative) Drawings for the fixed and movable cooler to the spherical black-body cavity	34
Annex G (informative) Guidance notes for operators using the spherical black-body cavity method	38
Annex H (normative) Electrical substitution radiometer (ESR) operating procedure	39
Annex I (normative) Procedure for heat flux meter calibration using the 25-mm VTBB method	

(method 3)	41
Annex J (normative) Data reduction procedure for the VTBB method (method 3)	43
Annex K (informative) Precision of calibration	45
Bibliography	46

Foreword

ISO (the International Organization for Standardization) is a worldwide federation of national standards bodies (ISO member bodies). The work of preparing International Standards is normally carried out through ISO technical committees. Each member body interested in a subject for which a technical committee has been established has the right to be represented on that committee. International organizations, governmental and non-governmental, in liaison with ISO, also take part in the work. ISO collaborates closely with the International Electrotechnical Commission (IEC) on all matters of electrotechnical standardization.

International Standards are drafted in accordance with the rules given in the ISO/IEC Directives, Part 2.

The main task of technical committees is to prepare International Standards. Draft International Standards adopted by the technical committees are circulated to the member bodies for voting. Publication as an International Standard requires approval by at least 75 % of the member bodies casting a vote.

Attention is drawn to the possibility that some of the elements of this document may be the subject of patent rights. ISO shall not be held responsible for identifying any or all such patent rights.

ISO 14934-2 was prepared by Technical Committee ISO/TC 92, *Fire safety*, Subcommittee SC 1, *Fire initiation and growth*.

This second edition cancels and replaces the first edition (ISO 14934-2:2006), which has been technically revised.

ISO 14934 consists of the following parts, under the general title *Fire tests — Calibration and use of heat flux meters*:

- *Part 1: General principles*
- *Part 2: Primary calibration methods*
- *Part 3: Secondary calibration method*
- *Part 4: Guidance on the use of heat flux meters in fire tests*

Introduction

In many fire test methods, the radiation level is specified and, therefore, it is of great importance that the radiant heat flux is well defined and measured with sufficient accuracy. Radiant heat transfer is also the dominant mode of heat transfer in most real fires.

In practice, radiant heat flux is usually measured with so-called total heat flux meters of the Schmidt-Boelter (thermopile) or Gardon (foil) type. Such meters register the combined heat flux by radiation and convection to a cooled surface. The contribution to the heat transfer by convection depends mainly on the temperature difference between the surrounding gases and the sensing surface and on the velocity of the surrounding gases. It will, however, also depend on size and shape of the heat flux meter, its orientation and on its temperature level, which is near the cooling water temperature. In many practical situations in fire testing, the contribution due to convection to the sensing surface of the instrument can amount to 25 % of the radiant heat flux. Thus it is always necessary to determine and control this part.

To determine the fraction of total heat flux due to radiation, a calibration scheme is developed where primary calibration is performed on two different types of heat flux meters: (1) a total hemispherical radiometer sensitive to radiation only, and (2) a total heat flux meter, (most frequently used) sensitive to both radiant heat transfer and to convective heat transfer. A comparison of measurements between the two types of meters in secondary (or transfer) calibration methods allows a characterization of the influence of convection in the method. Where possible, in all calibrations and measurements of radiative heat flux, the uncertainty calculations should include the uncertainty associated with removing the convective component. For secondary calibration methods, a combined use of hemispherical radiometers and total heat flux meters makes it possible to estimate the convection contribution. The same arrangement can be used in calibration of fire test methods as well.

Primary calibration is performed in a black-body cavity under conditions where the convective part of the heat transfer can be neglected or controlled. One such apparatus is an evacuated black-body facility with the unique characteristic of negligible convection and conduction effects described in this document as the vacuum black-body cavity (VBBC) method (method 1). Other (non-evacuated) black-body facilities can also be suitable as primary heat sources for calibration, providing they are fully characterized, particularly in terms of any convection effects on the sensing surface of the heat flux meter being calibrated. One such facility, described in this document as the spherical black-body cavity method (method 2), is a furnace with an orifice pointing downwards to minimize the convection. Another is the variable temperature black-body method (method 3) in which the effect of the convective component is minimized by the adoption of a substitution procedure in which the heat flux meter to be calibrated is compared with a primary standard radiometer. Under such conditions the convective effect for each measurement can be assumed to be of a similar magnitude.

NOTE Schmidt-Boelter meters and Gardon meters are examples of suitable products available commercially. This information is given for the convenience of users of this part of ISO 14934 and does not constitute an endorsement by ISO of this product.

Fire tests — Calibration and use of heat flux meters —

Part 2: Primary calibration methods

1 Scope

This part of ISO 14934 describes three methods for calibration of total hemispherical radiometers and total heat flux meters that are exposed to a well-defined radiation from a radiant heat source. The equipment is designed to minimize influences due to convective heat transfer during calibration. It is important to note that when the instruments are used in practice they measure a combination of radiant and convective heat transfers. The latter will depend on the design of the heat flux meter, the orientation, local temperature and flow conditions, and on the temperature of the cooling water.

2 Normative references

The following documents, in whole or in part, are normatively referenced in this document and are indispensable for its application. For dated references, only the edition cited applies. For undated references, the latest edition of the referenced document (including any amendments) applies.

ISO 13943, *Fire safety — Vocabulary*

ISO 14934-1, *Fire tests — Calibration and use of heat flux meters — Part 1: General principles*

IEC 60584-2, *Thermocouples — Part 2: Tolerances*

ISO/IEC Guide 98-3, *Uncertainty of measurement — Part 3: Guide to the expression of uncertainty in measurement (GUM:1995)*

ISO/IEC Guide 99, *International vocabulary of metrology — Basic and general concepts and associated terms (VIM)*

3 Terms and definitions

For the purposes of this document, the terms and definitions given in ISO 13943, ISO 14934-1, ISO/IEC Guide 98-3 and ISO/IEC Guide 99 apply.

4 Principles

4.1 General principles

Calibration of heat flux meters (total hemispherical radiometers and total heat flux meters) is performed with a black-body radiant heat source.

4.2 Principle of the vacuum black-body cavity (VBBC) method (method 1)

This method is used to calibrate heat flux meters between 2 kW/m² and 70 kW/m². It is designed to accept total heat flux meters or total hemispherical radiometers with a housing diameter of up to 50 mm. These may have pipes for water or/and air that are located axially. Calibration of heat flux meters consists of reading the output voltage of total heat flux meters or total hemispherical radiometers when irradiated by a traceable black-body radiant source operating under vacuum. By lowering the absolute pressure in the black-body cavity to between 0,5 Pa and 2 Pa, the convective heat transfer is significantly

reduced. Heat flux meters to be calibrated are fixed on a support and form a part of the closed system. The operating procedure is given in [Annex A](#). The relation between the furnace and the irradiance to the heat flux meter is given in [Annex B](#). Examples of computer screens are given in [Annex C](#).

4.3 Principle of the spherical black-body cavity method (method 2)

This method is used to calibrate heat flux meters between 2 kW/m² and 70 kW/m². A black-body radiant heat source designed as a spherical furnace with an aperture at the bottom is used. The temperature level of the furnace is controlled with high precision and is very uniform inside the furnace assuring a high precision of the radiant heat level.

Heat flux meters to be calibrated are inserted through the aperture at the bottom of the furnace with the sensing surface of the heat flux meter oriented horizontally. The influence of convection is thus reduced to a minimum. The heat flux meter sees nothing but the controlled environment of the black-body emitter. The radiation level of this black-body emitter depends primarily on the measured temperature making it traceable to international thermal calibration standards.

The accuracy of the method depends on the design of the test apparatus. The operating procedure is given in [Annex D](#). The relation between the furnace temperature and the irradiance to the heat flux meter is described in [Annex E](#). The limits of errors assume that the apparatus is constructed according to the figures in [Annex F](#). Guidance notes for operators are given in [Annex G](#).

4.4 Principle of the variable temperature black-body (VTBB) method (method 3)

The technique uses the principle of electrical substitution radiometry to calibrate heat flux sensors up to 50 kW/m². The sensors are calibrated with reference to a room-temperature electrical substitution radiometer whose calibration is traceable to a primary standard high accuracy cryogenic radiometer (HACR). This is a standard for optical radiation power and is supported through a chain of independent calibrations.

The calibration uses the 25 mm cavity diameter variable temperature black-body (VTBB) facility as broadband radiant source. The VTBB consists of a dual-cavity, electrically heated graphite tube. The black-body temperature is controlled and is stable within $\pm 0,1$ K of the set value.

The heat flux sensor to be calibrated and the reference standard radiometer are located at a fixed distance away from the black-body aperture, depending on the heat flux level. The variation in the incident heat flux level at the sensor location is obtained by varying the VTBB temperature. The operating procedure for electrical substitution radiometer is given in [Annex H](#). The calibration procedure is given in [Annex I](#). The data reduction procedure is given in [Annex J](#).

5 Suitability of a gauge for calibration

5.1 Types of heat flux meters

All three methods are intended for calibration of total hemispherical radiometers and of total heat flux meters. The total heat flux meters are usually of so called Schmidt-Boelter and Gardon types. Along with the experimental calibration data, an expression of the sensitivity of the heat flux meter is normally also given. It should be noted that for each given wavelength, λ , the heat flux meter has a specific spectral sensitivity. For heat flux meters used in fire tests, it can, however, be assumed that the sensitivity does not depend on the wavelength over the spectral range of the radiating sources commonly examined. Deviations from the ideal directional response characteristics may be neglected.

The field of view is assumed to be hemispherical (solid angle 180°), and the surface is assumed to behave as a perfect black-body, both regarding the spectral characteristics and the directional response.

The methods can be used for radiometers with a limited field of view, provided that this field of view is characterized, and that corrections made for this field of view are traceable.

5.2 Design of heat flux meters

Radiometers and heat flux meters with a housing diameter of up to 50 mm and a sensing surface diameter up to 10 mm can be accommodated in methods 1 and 2. During the calibration the heat flux meter body temperature must remain constant. This is usually achieved by using water-cooling. In some cases an air supply is used to keep the window free from dust. If possible, water and/or air supply piping are routed parallel to the axis of the meter so as to keep the lines within the housing diameter of 50 mm.

NOTE For the VTBB, there is no restriction on the sensor-housing diameter, and on how the cooling water or purge gas lines are routed. However, it is recommended that the sensing surface of the gauge is limited to less than 10 mm in diameter.

5.3 Measuring range

Radiometers are typically designed for use within a certain range. They should be calibrated within this range. For radiometers that will be used beyond the range of the method used extrapolation of the obtained calibration results may not be used unless justified.

5.4 Status of heat flux meter prior to calibration

The coating on the sensor is visually inspected, and if the conditions indicate the need for repainting, the customer is informed accordingly.

6 Vacuum black-body cavity (VBBC) method (method 1)

6.1 Apparatus

6.1.1 General description of apparatus for method 1

The primary calibration apparatus is a closed and insulated system including two essential parts (see a schematic drawing in [Figure 1](#)):

- a gun which is a moving cylindrical tube (1) including the electrically heated [(3), (6)], black-body cavity (4), the diaphragms (5), the heat flux meter (10) and its cooling pipes,
- an insulated and cooled chamber (2).

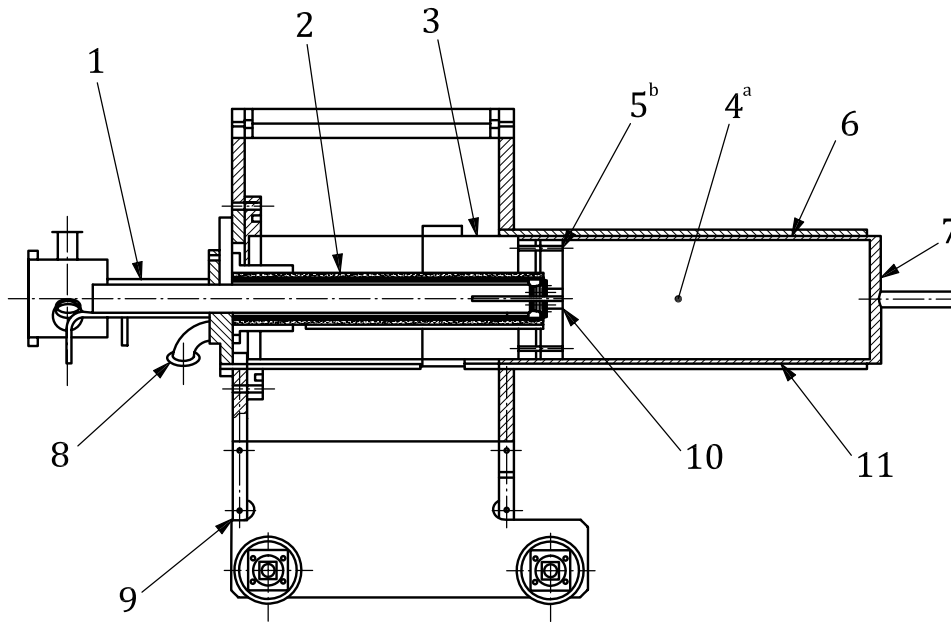

Key

- 1 water cooled heat flux meter holder
- 2 ceramic tube
- 3 electric heater
- 4 black-body cavity
- 5 diaphragm
- 6 three electric heaters
- 7 multi-points radial thermocouple
- 8 vacuum pump
- 9 mobile carriage
- 10 heat flux meter
- 11 multi-points longitudinal thermocouple

a See [Figure 3](#).

b See [Figure 2](#).

Figure 1 — Cross-section of the furnace (VBBC)

6.1.2 The vacuum black-body cavity (VBBC)

The cavity is a horizontally orientated cylinder with a diameter of about 160 mm and a length of about 420 mm (see [Figures 2](#) and [3](#)). The heat flux meter is put flush to the diaphragm in order to close the system composed of the black-body and the diaphragm.

The black-body cavity is put under vacuum using a combination of a primary pump and a molecular turbo pump. The pressure within the cavity is measured and recorded continuously.

The black-body cavity is electrically heated through the cylindrical wall by means of coils. Four proportional integral differential regulators (PID) control the heating of the cavity. These PID controllers maintain the black-body temperature to approximately $\pm 0,3$ K of the set value. A ceramic jacket is placed around the cavity to reduce heat losses. The heat flux meter is surrounded by three diaphragms in order to reflect the radiation coming from the cavity and to limit the losses generated by this opening. The black-body can be operated up to a temperature of about 900 °C.

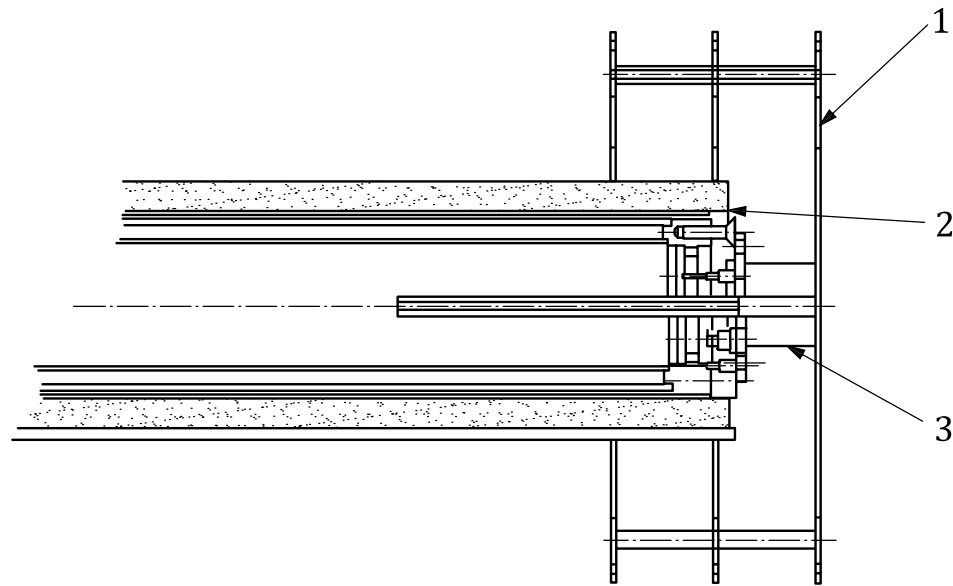
**Key**

- 1 diaphragm
- 2 heat flux meter interface for smooth body with and without flange
- 3 heat flux meter

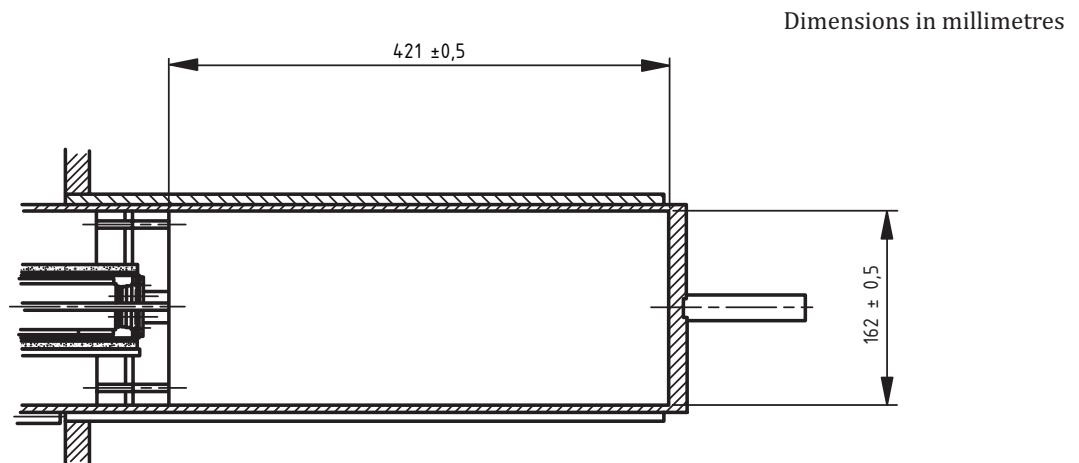
Figure 2 — Cross-section of the heat flux meter flush to the diaphragms**Figure 3 — Cross-section of the black-body cavity****6.1.3 Temperature measurement**

Temperature profiles of the cavity are measured with thermocouples.

- a) A set of type-S thermocouples measure the radial temperature variation at the back of the cavity; radial positions of the thermocouples from the centre are 0 mm, 27 mm, 54 mm, 81 mm.
- b) Type-K thermocouples are inserted at different points along the cavity to measure the temperature gradient. Positions of the thermocouples from the front of the black-body are 0 mm, 17 mm, 33 mm, 50 mm, 67 mm, 83 mm, 100 mm, 133 mm, 167 mm, 200 mm, 250 mm, 300 mm, 350 mm, 410 mm.

- c) A ceramic tube containing a calibrated type-S thermocouple is used to give a reference and to check the temperature variation along the cavity.

6.1.4 Pressure measurement

The pumping system is composed of two pumps:

- a) mechanical primary pump, which lowers the pressure from the atmospheric pressure to 10 000 Pa,
- b) molecular turbo pump, known as the secondary pump, which makes it possible to reduce the pressure to less than 1 Pa. The measurement of the pressure is performed using a Pirani gauge.

Returning to atmospheric pressure is carried out under nitrogen.

6.1.5 Data measurement and software – interfacing of the calibration set-up

The incident heat radiation on a heat flux sensor inserted in the black-body cavity can be determined from measuring the temperatures and pressure in the cavity and the position and geometry of the sensor. A systematic calculation has been developed to determine the incident heat radiation.

The response of the heat flux meter and different thermocouples are measured using a voltmeter with the appropriate accuracy. All required output voltages (pressure gauge, thermocouple, etc.) are recorded using a scanning data logging system.

The data reduction and calculation of the irradiance produced on the sensor is carried out using a special computer routine.

6.2 Operating procedure

The heat flux meter is inserted into the black-body cavity working under vacuum. In this case and to a first approximation, the heat flux meter output signal is directly proportional to the total incident heat flux irradiating the sensor.

In a preliminary step, the relationship between total incident heat flux on a typical laboratory heat flux meter and cavity temperature was calculated using a net heat radiation method and convection heat transfer modelling inside the black-body cavity. Then, when a heat flux meter is calibrated, this relationship with the same assumptions about experimental boundary conditions is used to obtain the total incident heat flux from measurements of cavity temperature.

The calibration procedure is given in detail in [Annex A](#). The data reduction procedure is described in [Annex B](#).

6.3 Uncertainty

6.3.1 Uncertainty in general

The estimation of the expanded uncertainty of a measurement is based on an analysis of the main sources of uncertainties. The contribution of each component arising from the method, the medium and the devices used is analysed. A summary of the estimated uncertainties is given in [Table 1](#).

6.3.2 Black-body temperature, heat transfer modelling and emissivity

The black-body temperature component takes all details of a temperature measurement into account. Heat transfer modelling component is obtained by an analysis of the influence of thermocouple positions, radiation and convection modelling and thermal resistance (about 1,3 % at low heat flux level). This part is the most important source of uncertainty. Emissivity uncertainty of each part of the black-body cavity can be considered as a negligible contribution to the total uncertainty.

6.3.3 Pressure output reading

The uncertainty on the pressure output reading is determined from details of the calibration and resolution of the instruments.

6.3.4 Radiometer reading

This contribution is calculated for a water-cooled gauge. Repeatability and influence of the cooling flow are in particular taken into account. Depending of the heat flux level, different scenarios for data acquisition of radiometer readings are applied. The result obtained is a compromise between the effect of time of equilibrium in the calibration programme heat flux levels and the resistance of the gauge's coating.

Table 1 — Summary of sources of uncertainty

Uncertainty source	Type	Relative uncertainty ± % at					
		272 °C (5,0 kW/ m ²)	375 °C (10,0 kW/ m ²)	542 °C (25,0 kW/ m ²)	671 °C (45,1 kW/ m ²)	700 °C (50,8 kW/ m ²)	800 °C (75,2 kW/ m ²)
Black-body temperature	A-B	0,24	0,20	0,20	0,19	0,19	0,18
Heat transfer modelling	B	1,27	1,07	0,85	0,73	0,71	0,64
Black-body emissivity	B	0,00	0,00	0,00	0,00	0,00	0,00
Pressure output reading	B	0,10	0,07	0,03	0,02	0,02	0,01
Radiometer reading	A-B	0,84	0,54	0,43	0,42	0,41	0,41
Combined expanded relative uncertainty	(<i>k</i> = 2)	3,1	2,4	1,9	1,7	1,7	1,6

The relative expanded uncertainty (*k* = 2) is estimated to be less than ± 2,5 % for the heat flux range between 10 and 75 kW/m².

7 Spherical black-body cavity method (method 2)

7.1 Apparatus

7.1.1 General description of apparatus for method 2

The method is a semi-closed method based on the use of a well-insulated, electrically heated spherical furnace chamber. A water cooled heat flux meter holder housing the heat flux meter is inserted in the opening at the bottom of the furnace. The furnace is shown in [Figure 4](#).

The spherical furnace should have a large area compared to the opening to act as a nearly perfect black-body emitter. The aperture in the water cooled sight tube defines the view factor under which the furnace radiates to the heat flux meter. The sight tube and the heat flux meter with its holder are at the bottom of the furnace to reduce the effect of convective currents.

7.1.2 The spherical furnace chamber

The spherical furnace consists of an inner shell of Inconel¹⁾ material which is heavily oxidized to enhance its spectral emissivity. On the outside of that Inconel shell, evenly distributed electrical heating coils are attached with a ceramic compound with good thermal conductivity. The furnace chamber is embedded in high temperature resistant ceramic insulation to minimize heat losses and establish an even temperature distribution. The inner diameter of the furnace chamber should be larger than 4,5 times the restricting aperture of the water cooled sight tube.

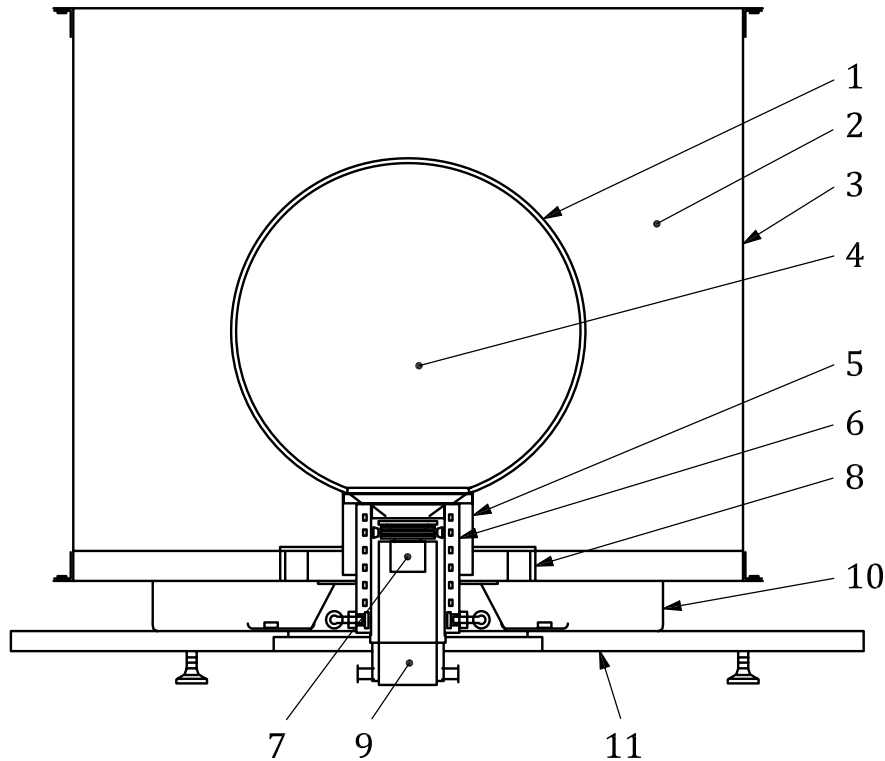

Key

- 1 spherical cavity with heater in ceramic casting
- 2 low density ceramic insulation
- 3 interior stainless steel housing
- 4 thermocouple attached to sphere interior surface
- 5 hard ceramic insulator
- 6 water cooled sight tube
- 7 heat flux meter
- 8 ceramic insulator stand-offs
- 9 movable, water cooled, heat flux meter holder
- 10 interior support structure
- 11 bottom face plate

Figure 4 — Vertical cross-section of the spherical furnace

1) Inconel is an example of a suitable product available commercially. This information is given for the convenience of users of this part of ISO 14934 and does not constitute an endorsement by ISO of this product.

7.1.3 The sight tube and the heat flux meter holder

The water cooled sight tube consists of an assembly of concentric cylinders, with a system of water channels in between. The sight tube shall be carefully machined to accurate dimensions. Its top opening forms an aperture, through which the furnace radiates to the heat flux meter. Some distance down (X_1 in Figures 5 and 6), a flange is located. This flange serves partly as a stray radiation shield, but mainly as a rest, in order to position the water cooled heat flux meter holder exactly. The sight tube with the heat flux meter holder is shown in Figure 5 where the main details are identified.

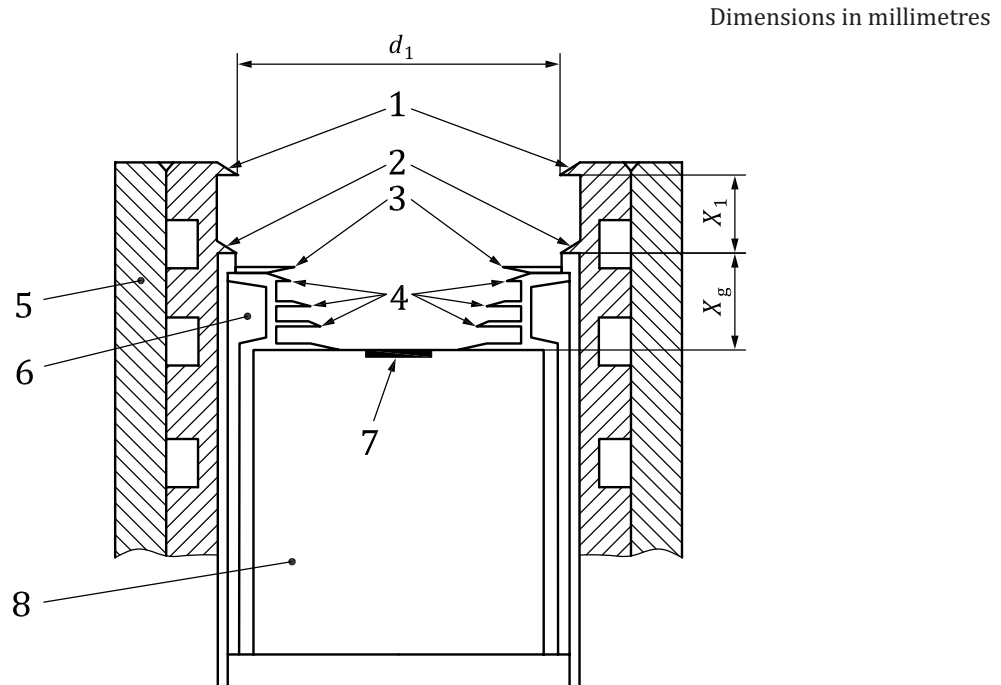

Key

- 1 restricting aperture
- 2 upper shielding flange and rest for heat flux meter holder
- 3 aperture disc
- 4 shielding flanges of heat flux meter holder
- 5 inner part of sight tube with water channels
- 6 heat flux meter holder with water channels
- 7 sensing surface
- 8 heat flux meter body (schematic)

NOTE 1 The aperture diameter, d_1 , is $(60,18 \pm 0,01)$ mm and the distance X_1 is $(13,05 \pm 0,03)$ mm. Note that the distance X_g varies, depending on the heat flux meter design, as it is the distance between the top of the holder and the sensing surface of the heat flux meter. Normally it is around 17 mm.

NOTE 2 The figure shows the cross-section at the level of the cut. Parts that lay behind the cut and that should be visible are not included.

Figure 5 — Cross-section of the inner part of the water cooled sight tube with the heat flux meter holder in its top position. This option is referred to as without spacer ring

Dimensions in millimetres

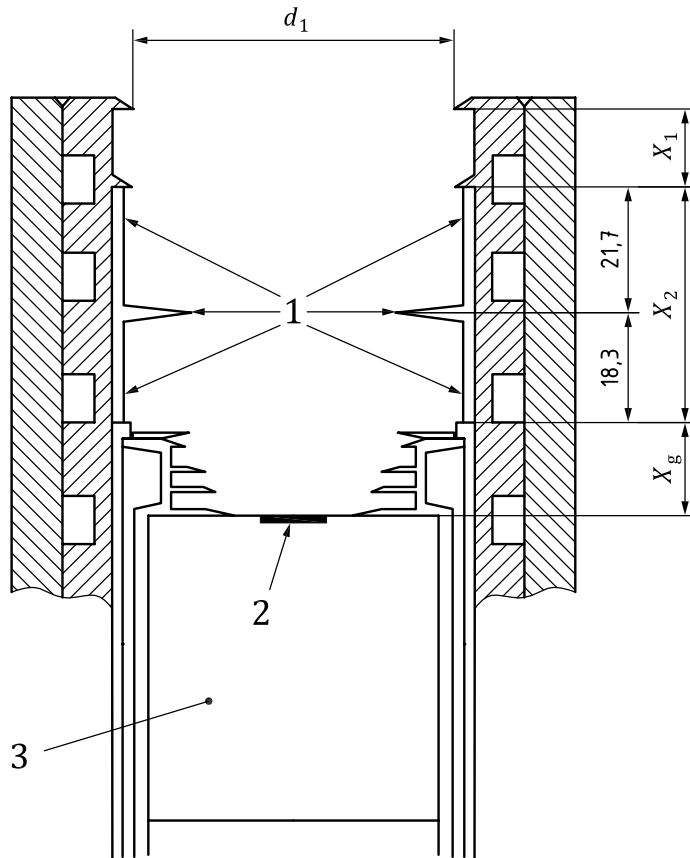

Key

- 1 spacer ring with shielding flange
- 2 sensing surface
- 3 heat flux meter body (schematic)

NOTE 1 The distance X_2 is $(40 \pm 0,02)$ mm.

NOTE 2 The figure shows the cross-section at the level of the cut. Parts that lay behind the cut and that should be visible are not included.

Figure 6 — Cross-section of the inner part of the water cooled sight tube with the heat flux meter holder 40 mm below the top position and with the spacer ring inserted. This option is referred to as with spacer ring

The sight tube is designed for use with the heat flux meter holder in two positions without causing reflections from the cooler walls. The top position (without spacer ring) and a position 40 mm below that (with spacer ring) provides for radiation ranges of 6 kW/m^2 to 75 kW/m^2 and 2 kW/m^2 to 25 kW/m^2 , respectively, at the temperature interval $400 \text{ }^\circ\text{C}$ to $1\ 000 \text{ }^\circ\text{C}$. The sight tube and the heat flux meter holder shall be accurately manufactured to provide an exact input for calculation of the radiation level at the sensing surface.

[Figure 5](#) shows the heat flux meter holder in its top position. The holder has a number of flanges which protect the heat flux meter from receiving radiation reflected from the cooled holder wall. The flanges also help to conserve the stratification of air, which reduces convective heat transfer to the heat flux meter sensing surface.

[Figure 6](#) shows the heat flux meter holder in its lowest position, with the spacer ring inserted between the stop flange and the holder. Inside the removable spacer ring there is another flange for shielding of reflection. The spacer also serves to ensure exact positioning of the holder in its lowest position.

If the diameter of the heat flux meter body is smaller than the inside diameter of the heat flux meter holder, a fixture shall be used to position the heat flux meter along the centre line of the holder.

7.1.4 Temperature measurement

The furnace temperature is measured with thermocouple type S (Platinum-Platinum/Rhodium) with protective alumina sheathing of high purity. The bare-wires of the thermocouple are welded together with a bead size of about 1,2 mm. The thermocouple is further protected against radiation by inserting it into welded tubing into the interior of the inner shell of the Inconel sphere.

The cooling water temperature is measured with a type K thermocouple. The thermocouple for measuring the temperature of the cooling water is inserted into the water pipe near to the heat flux meter and its holder.

The thermocouples shall be of tolerance class 1 in accordance with IEC 60584-2.

The final calibration of the whole system shall be performed radiometrically by using a calibrated pyrometer with a calibration uncertainty of ± 1 °C up to 1000 °C or better.

7.1.5 Dimension measurement

The heat flux meter depth (X_g) shall be measured with a calibrated dimension gauge having a resolution of 0,01 mm. The area of the heat flux meter's sensing surface shall be determined with a relative standard uncertainty less than 10 %.

7.1.6 Data logger

The data logging system should have appropriate accuracy to handle the signals from the temperature sensors as well as the low level voltage from the heat flux meter. The error after calibration should be less than ± 10 μ V. The accuracy of the temperature reading is determined so that the overall temperature uncertainty shall be less than 1,4 °C.

To account for possible errors in the rest of the measuring chain, the same logger and connectors should be used wherever possible in both calibration and actual measurement.

7.2 Operating procedure

Heat flux meters should be calibrated at 10 different flux levels, evenly distributed.

The procedure for a normal calibration is given in [Annex D](#). The data reduction procedure is described in [Annex E](#).

7.3 Uncertainty

7.3.1 Uncertainty in general

The estimation of the expanded uncertainty of a measurement is based on an analysis of the main sources of uncertainties. The contribution of each component arising from the method and the devices used is analysed. A summary of the estimated uncertainties is given below and in [Table 2](#) and [Table 3](#).

The error analysis for this system assumes that the water-cooled sight tube and heat-flux-meter holder are manufactured in accordance with the supplied drawings ([Annex F](#)). For a detailed error analysis, see References [\[5\]](#) and [\[11\]](#).

7.3.2 Approximations in the enclosure model and error due to reflection

The uncertainties due to the approximations in the enclosure model (see right part of [Figure E.2](#) in [Annex E](#)) and due to reflection errors act in different directions. The enclosure model assuming the cooler is a cylinder gives a relative error of 0 % to 0,5 % while the reflection error is estimated to be -0,8 % to 0 %. Combining them using the square root sum of squares and assuming a rectangular distribution of the errors results in a relative standard uncertainty of 0,54 %.

7.3.3 Convection

The maximum error from convection is estimated to $\pm 0,5$ % which results in a relative standard uncertainty of 0,29 %.

7.3.4 Emissivity of walls

The emissivity of the furnace wall influences the apparent emissivity of the furnace. The relative sensitivity coefficient calculated by parameter variation is 0,017. Assuming an emissivity of the furnace wall of 0,7-0,9 and a rectangular distribution results in a relative standard uncertainty of 7,2 %. The contribution to the combined relative uncertainty of the heat flux measurement is 0,12 %.

7.3.5 Aperture diameter

The furnace aperture influences both the apparent emissivity of the furnace and the view factors. The relative sensitivity coefficient calculated by parameter variation depends on whether a spacer ring is used or not but not on the furnace temperature. When no spacer ring is used the sensitivity coefficient becomes 1,0 while it is 1,65 when the spacer ring is used. Assuming a rectangular distribution results in a 0,02 % contribution to the combined relative uncertainty when no spacer ring is used for a 60 mm aperture. When the spacer ring is used, the contribution is 0,03 %.

7.3.6 Furnace diameter

The furnace diameter influences the apparent emissivity of the furnace. The relative sensitivity coefficient is calculated as 0,0056 without spacer ring and 0,0057 with spacer ring. Assuming a triangular distribution gives a relative standard uncertainty of 0,44 % and a contribution to the combined relative uncertainty of 0,0034 % without spacer ring and 0,0035 % with spacer ring.

7.3.7 Dimensions of cooler

The different dimensions of the cooler influence the view factors. The dimensions where there is a need for estimation of uncertainty are as follows: Distance in fixed cooler, x_1 , size of spacer ring, x_2 , and insertion depth, x_g . The relative standard uncertainty for x_1 is 0,23 %. For the insertion depth it is 0,3 % and for the size of the spacer ring 0,0058 %. The relative sensitivity coefficients are given in [Table 2](#) and [Table 3](#).

7.3.8 Temperature of cooler

The cooler is divided into two parts in the calculations, the upper and lower part. These two sections are assumed to have a uniform temperature each. The temperature of each part is the mean value of several temperatures in different locations in the cooler and it is assumed that this mean value is representative for the relevant overall cooler temperature. The uncertainty is due to this approximation and is estimated to give a contribution of between 0,012 (with spacer ring) and 0,048 (without spacer ring) as presented in [Table 2](#) and [Table 3](#). The relative sensitivity coefficients depend on both the furnace temperature and whether a spacer ring is used or not. Due to the low contribution to the combined relative uncertainty an average value of the coefficients at different temperatures is used.

7.3.9 Temperature of cooling water

Assuming a rectangular distribution and a water temperature of 25 °C (298 K) the relative standard uncertainty is 0,67 %. The relative sensitivity coefficient for the cooling water temperature depends on

both the furnace temperature and whether a spacer ring is used or not. Due to the low contribution to the combined relative uncertainty an average value of the coefficients at different temperatures is used.

7.3.10 Temperature of furnace

The uncertainty of the furnace temperature has a large impact on the uncertainty of the heat flux as indicated by the relative sensitivity coefficient of 4,66. The standard uncertainty of the temperature measurement is estimated to 1°C which results in a relative standard uncertainty of 0,15 % at 370°C (643 K) and 0,079 % at 1000°C (1273 K).

7.3.11 Area/diameter of sensing surface

The radius of the sensitive element of the meter is provided by the manufacturer of the heat flux meter or measured in each calibration. Assuming an uncertainty of 0,05 and a triangular distribution gives the relative standard uncertainty of 6,8 %. The sensitivity coefficient is estimated to 0,0049 without spacer ring and 0,0026 with spacer ring.

7.3.12 Voltage measurement

The uncertainty in voltage depends on the data logger used. The values in [Table 2](#) and [Table 3](#) are based on a $\pm 2 \mu\text{V}$ calibration.

Table 2 — Summary of sources of uncertainty for the option without spacer ring, see [Figure 5](#)

Uncertainty source Component	Type	Relative sensitivity coefficient	At 370 °C		At 1 000 °C	
			Relative Standard uncertainty	Contribution to combined relative uncertainty	Relative Standard uncertainty	Contribution to combined relative uncertainty
			%	%	%	%
Approximations in the enclosure model and unwanted reflections	B		0,5	0,5	0,5	0,5
Convection	B		0,3	0,3	0,3	0,3
Emissivity of walls	B	0,017	7,2	0,12	7,2	0,12
Aperture diameter	B	1	0,019	0,019	0,019	0,019
Furnace diameter	B	0,0056	0,62	0,0034	0,62	0,0034
Distance in fixed cooler, x_1	B	0,43	0,23	0,099	0,23	0,099
Insertion depth, x_g	B	0,57	0,3	0,17	0,3	0,17
Temperature of cooler	B	0,03	1,6	0,049	1,3	0,039
Temperature of cooling water	B	0,078	0,67	0,052	0,67	0,052
Area of sensor	A	0,0049	8,7 ^a	0,042	8,7 ^a	0,042
Temperature of furnace	A	4,66	0,15	0,72	0,079	0,37
Voltage measurement ($\pm 2\mu\text{V}$)	A		0,041	0,041	0,0041	0,0041
Combined expanded relative uncertainty	$k = 2$			1,6		1,1

^a Typical value, depends on the calibrated sensor

Table 3 — Summary of sources of uncertainty for the option with spacer ring, see Figure 6

Uncertainty source Component	Type	Relative sensitivity coefficient	At 370 °C		At 1 000 °C	
			Relative Standard uncertainty	Contribution to combined relative uncertainty	Relative Standard uncertainty	Contribution to combined relative uncertainty
			%	%	%	%
Approximations in the enclosure model and unwanted reflections	B		0,5	0,5	0,5	0,5
Convection	B		0,3	0,3	0,3	0,3
Emissivity of walls	B	0,017	7,2	0,12	7,2	0,12
Aperture diameter	B	1,65	0,019	0,032	0,019	0,032
Furnace diameter	B	0,0057	0,62	0,0035	0,62	0,0035
Distance in fixed cooler, x_1	B	0,31	0,23	0,071	0,23	0,071
Size of spacer ring	B	0,96	0,0058	0,0056	0,0058	0,0056
Insertion depth, x_g	B	0,41	0,3	0,12	0,3	0,12
Temperature of cooler	B	0,0095	1,6	0,016	1,3	0,012
Temperature of cooling water	B	0,074	0,67	0,05	0,67	0,05
Area of sensor	A	0,0026	8,7 ^a	0,023	8,7 ^a	0,023
Temperature of furnace	A	4,66	0,15	0,73	0,079	0,37
Voltage measurement ($\pm 2\mu V$)	A		0,041	0,041	0,0041	0,0041
Combined expanded relative uncertainty	$k = 2$			2,5		1,8

^a Typical value, depends on the calibrated sensor

8 Variable-temperature black-body (VTBB) method (method 3)

8.1 Apparatus

8.1.1 General description of apparatus for method 3

Figure 7 shows a schematic layout of the VTBB apparatus and the calibration scheme. The basic components are the cylindrical tube cavity providing broadband black-body radiation, the controller with pyrometer for temperature control, reference standard radiometer, test sensor and the associated data acquisition system.

8.1.2 Black-body cavity

The cylindrical cavity of the black-body is a thermally insulated graphite tube heated electrically. Direct resistance heating using large ac currents at low voltages provides for quick heating and cooling. The heated tube cavity diameter is 25 mm, and the heated section is 28,2 cm long with a centre partition, 0,3 cm thick.

The tube end caps are water-cooled and are directly connected to the heating electrodes. The design provides a sharp temperature gradient between the end cap and the graphite heater element. This helps in achieving a uniform temperature distribution along the cavity length of the graphite tube. Different lengths of graphite extension tubes can be attached to the end caps.

The radiating cavity is purged with argon gas during operation to prevent oxidation at low temperatures and sublimation at high temperatures.

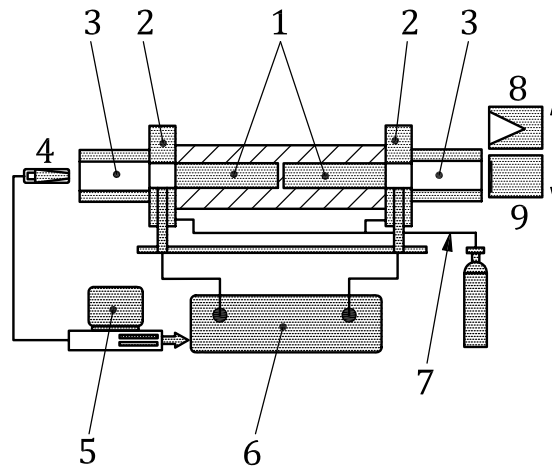

Key

- 1 heated graphite tube dual-cavity
- 2 water-cooled copper end caps
- 3 graphite tube extension (not cooled)
- 4 control pyrometer
- 5 temperature controller/computer
- 6 power supply
- 7 purge gas lines (argon)
- 8 transfer standard radiometer
- 9 test heat flux sensor

Figure 7 — Schematic layout of the 25 mm variable-temperature black-body of method 3

8.1.3 Temperature measurement/control

An optical pyrometer measures the black-body temperature by sensing radiation from one end of the furnace. Four different aperture filters are used with the pyrometer to cover the black-body operating temperature range from 973 K to 2 973 K. The output of the pyrometer is also used for black-body temperature control to the set value. A PID controller regulates the power supply to maintain the black-body cavity temperature to within $\pm 0,1$ K of the set value. The maximum recommended operating temperature for the furnace is 2 973 K.

8.1.4 Reference standard radiometer

The reference standard radiometer is a room-temperature electrical substitution radiometer (ESR) ([Figure 8](#)). The radiometer is water-cooled and is suitable for continuous operation. The incident heat radiation from the radiating source is nearly completely absorbed by multiple internal reflections within the black-cavity of the radiometer, to within a few fractions of a percent. The electrical power required to produce the same temperature rise in the cavity as the incident heat radiation is determined by measurement of voltage and current through a precision resistor. A radiometer is used to directly measure the actual incident heat radiation; hence, the uncertainty in the absolute temperature of the black-body cavity and the cavity emissivity do not influence the uncertainty in the flux measurement, as long as the cavity temperature remains stable in the time between the exposure of the ESR and the calibration of the gauge. The radiometer used covers a range from 0,4 kW/m² to 42 kW/m², and has a view angle of 86° and an aperture area of 0,992 5 cm². The radiometer has a time constant ($1/e$) of 6 s for a step change in irradiance. For large changes in heat flux level, it is necessary to allow about 60 s

for stabilization before measurements are made. For flux traceability, the ESR measurement should be directly traceable to a flux standard like HACR.

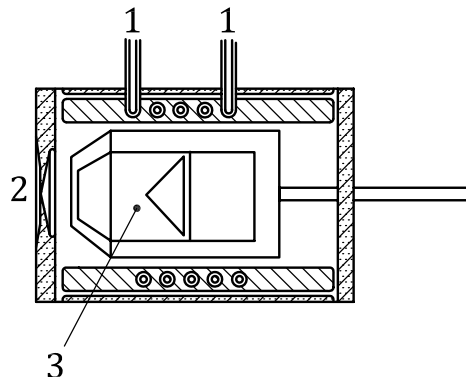

Key

- 1 cooling water
- 2 aperture
- 3 cavity

Figure 8 — Schematic layout of the reference electrical substitution radiometer

8.1.5 Radiometer and test sensor installation

The test sensor and the reference radiometer are located outside the black-body exit in a test-plane at a fixed distance from the black-body aperture. The distance between the black-body and the test plane depends on the calibration heat flux range. The black-body exit location is used as a reference plane for locating the sensor/radiometer with standard gauge blocks. For calibrations up to 50 kW/m², the test-plane is 12,5 mm away from the reference plane. For calibrations in the lower ranges of 25 kW/m² and 10 kW/m², the test-plane is at 62,5 mm and 140 mm away from the reference plane, respectively. The test sensor is mounted on a holder. Standard mounting blocks and holders are available for mounting 25 mm Gardon and 5 mm Schmidt-Boelter sensors. For water-cooled sensors, a re-circulating water pump is used for cooling.

8.1.6 Data acquisition

The sensor and the radiometer outputs are connected to different channels of a multiplexed digital voltmeter. After stabilization of the temperature, the black-body unit is positioned first in front of the radiometer and then the test sensor. The calibration is carried out sequentially; first measuring the flux with the radiometer followed by sensor output. The recording of the instrument output by the digital voltmeter is triggered by a computer command. The signal reading and the corresponding time are recorded for the test duration in approximately 0,4 s interval and the data are stored in a specified file for further analysis.

8.2 Operating procedure

8.2.1 Operating procedure in general

The sensors received for calibration are first inspected for continuity and the condition of the absorptance coating on the sensor surface. The value of the resistance measured by a multi-meter is recorded. The calibration procedure in the VTBB is given in detail in [Annexes H](#) and [I](#).

8.2.2 Radiometer self-calibration

[Annex H](#) describes the self-calibration of the radiometer, which shall be performed before the radiometer is used. While the incident heat radiation values are arrived using the actual calibration of the radiometer, the self-calibration is necessary to be consistent with the radiometer settings during calibration and use. In general, the self-calibration is carried out at a power level of about 920 mW.

8.2.3 Sensor calibration in VTBB

The heat flux sensor to be calibrated and the reference radiometer are located at a fixed distance away from the exit of the black-body depending on the range of calibration. [Annex I](#) gives the procedure for making calibration measurements. The measurements are made at 5 to 10 heat flux levels within the range of calibration. [Table 3](#) gives the approximate temperature settings of the VTBB and the corresponding heat flux level at the sensor for different locations from the black-body aperture. The values of heat flux listed in [Table 3](#) help in determining the best location for the sensor with reference to the black-body aperture.

Table 4 — Heat flux values at sensor plane for different black-body temperatures

$X = 12,5 \text{ mm}^a$		$X = 62,5 \text{ mm}^a$		$X = 140 \text{ mm}^a$	
Temperature	Heat flux	Temperature	Heat flux	Temperature	Heat flux
K	kW/m ²	K	kW/m ²	K	kW/m ²
1573	9	1823	5	1573	1
1773	13	1963	7	1973	3
1973	19	2108	10	2273	5
2123	24	2233	12	2473	7
2273	31	2373	15	2573	8
2373	36	2573	20	2673	10
2453	41	2773	27		
2553	47				
2653	55				

^a Distance from black-body exit to radiometer/sensor location.

8.2.4 Data reduction

The data reduction procedure is described in [Annex J](#). The measured responsivity of the sensor is expressed in mV/(kW/m²). The regression curve fit for the data are generally linear with regression factors close to unity. In some cases, a small degree of nonlinearity may be observed at low heat flux levels, when calibrating with the radiometer/sensor located close to the black-body exit, due to argon gas flow effects. However, this effect reduces with increasing heat flux and the responsivity is largely determined by the readings at high heat flux levels.

8.2.5 Convective heat flux error

The gauge surface temperature rises during calibration due to radiant heating. Since the calibration is under ambient conditions, a free-convection flow develops leading to heat loss from the gauge surface and a net reduction of the heat flux measured by the gauge. The correction due to convective heat loss is negligible if the gauges are water-cooled or if the calibration duration is short with no significant rise in the surface temperature. The convection heat-loss when not negligible often appears as a nonlinearity in the gauge response for increasing incident radiant heat flux.

If the gauge surface temperature-rise during calibration is significant, a correction for the calculated flux due to convective heat loss at the gauge location is necessary. Theoretical estimate for the convective heat loss is possible by approximating the gauge surface by a simplified flat-plate configuration. The

convection losses increase with decreasing surface area exposed to free convection. The calculations show the 1,0 cm × 1,0 cm heated vertical plate 50 K above the surroundings temperature, the maximum convection heat loss is about 0,6 kW/m². By limiting the gauge surface temperature-rise, it is possible to minimize the convective heat loss. However, it is necessary to ensure the convective heat losses are within the desired accuracy for the specific test conditions, or to correct for convection losses.

8.3 Uncertainty

8.3.1 Uncertainty in general

The uncertainties are grouped under two categories; Type-A evaluated using statistical methods, and Type-B evaluated by other means. The individual uncertainties are then combined using the square root of the sum-of-the squares to arrive at the combined measurement uncertainty.

8.3.2 Reference standard radiometer

The uncertainty associated with the calibration of the transfer standard is obtained from previous measurements discussed. This is considered as a Type-B uncertainty and estimated to be 0,6 %.

8.3.3 Black-body parameters

The primary standard VTBB has a long-term stability within ± 0,1 K of the set temperature. The corresponding uncertainty in the radiant heat flux will be 0,01 % at 1 000 K and 0,004 % at 2 773 K. This is negligible compared to the other test uncertainties and can be ignored. The black-body emissivity has no influence on the calibration. Higher values of emissivity help in realizing higher heat flux levels at the sensor surface for a given operating temperature. The uniformity of radiation from the black-body aperture has no major influence on the calibration because of identical effects on both the reference standard and the test sensor.

8.3.4 Alignment errors

The test sensor and the radiometer are positioned at a fixed distance from the black-body exit using a gauge block, and the black-body exit as the reference plane. The effective radiating aperture is nearer to the heated end of the graphite tube cavity, which is about 8,5 cm inside of the black-body exit with the short extension piece installed. Assuming a maximum error of about 0,2 mm in the location of the radiometer and the sensor with respect to the reference plane, the corresponding uncertainties will be 0,2 %, 0,14 % and 0,09 % at sensor locations of 12,7 mm, 62,5 mm and 140 mm, respectively. The corresponding uncertainty in heat flux will be 0,4 %, 0,3 % and 0,2 % at sensor locations of 12,7 mm, 62,5 mm and 140 mm, respectively. The errors due to angular misalignment vary as the cosine of the angle. Assuming a maximum misalignment of about 2°, the corresponding uncertainty will be 0,06 %.

8.3.5 Aperture size effect

Due to different sensing areas of the radiometer and the sensor, a correction to the radiometer measurement may be necessary in some cases to account for the non-uniform distribution of the heat flux across the sensing area. This correction can be estimated by considering the variation of the view factor across the radiometer aperture. For the VTBB calibration set-up, the correction is less than 0,3 % of the measured radiometer reading.

8.3.6 Radiometer/sensor reading

The sensor and the radiometer readings are averaged over a period of 10 s to 60 s depending on the heat flux level. If the sensors are water-cooled, longer averaging times can be used. Because of long time constant, the unsteadiness in the radiometer output due to purge gas flow and other effects will be much less compared to the sensor output which has a time constant of 50 ms to 300 ms. The standard deviation of the mean (standard error) of the sensor output measured at two locations from the black-

body exit shows a uncertainty of about 0,2 % and reducing significantly at higher heat flux levels greater than 10 kW/m².

8.3.7 Long-term repeatability

The long-term repeatability of the calibration procedure in the VTBB is monitored through calibration of a reference Schmidt-Boelter sensor at frequent intervals. This reference sensor is calibrated each time before a customer calibration is performed. The uncertainty due to long-term repeatability of the procedure is determined from results of several tests on this reference Schmidt-Boelter sensor in the same facility and using similar instrumentation and experimental set up.

8.3.8 Combined uncertainty

The individual uncertainties discussed above have been listed in [Table 4](#) and the combined uncertainty (u_c) determined by calculating the square root of the sum-of-the-squares of individual uncertainties. The relative expanded uncertainty (U) expressed for a coverage factor of $k = 2$, is about 2 %. The uncertainty values shown correspond to a typical Gardon sensor calibration.

**Table 5 — Summary of sources of uncertainty in the measurement range of heat fluxes
10 kW/m² to 50 kW/m²**

Uncertainty source	Type	Relative uncertainty %
Reference radiometer	B	0,6
Black-body temperature	B	0,1
Black-body emissivity	B	0,0
Black-body aperture uniformity	B	0,0
Sensor/radiometer alignment (distance)	B	0,4
Sensor/radiometer alignment (angular)	B	0,1
Radiometer aperture averaging effect	B	0,1
Radiometer output reading	A	0,2
Sensor output reading	A	0,2
Repeat tests on a similar gauge	A	0,7
Combined expanded relative uncertainty	$k = 2$	2,1

9 Number of calibration levels

Heat flux meters should normally be calibrated at 10 different flux levels. The radiation levels chosen for the calibration could be either evenly distributed over the range 0 kW/m² to the maximum allowable of the heat flux meter, or more concentrated in a range of particular interest.

The number of radiation levels used for calibration influences the uncertainty in the regression of the calibration. When a linear regression has been performed then the standard deviation is calculated either by means of the computer program used for the regression or by

$$\hat{s}^2 = \frac{1}{\nu} \sum_{i=1}^m (\hat{y}_i - y_i)^2 \quad (1)$$

where

ν is the number of degrees of freedom;

m is the number of radiation levels;

\hat{y}_i is the value from the model;

y_i is the measured value for the level x_i .

The number of degrees of freedom, ν , equals number of radiation levels minus the number of parameters that are set in the regression, i.e. Two for linear regression. The uncertainty for the regression curve is then calculated as the standard deviation times a coverage factor in order to get a 95 % confidence interval. If the degree of freedom is small, i.e. less than 10 then this shall be taken from the t -distribution.

10 Expression of results

The calibration results should be reported in a table with the contents as given in the list below:

- total heat flux, q_{tot} (kW/m²);
- incident heat radiation, I_{rad} (kW/m²);
- output voltage, U_{out} (mV).

A graph should be plotted of the total heat flux, q_{tot} (kW/m²) versus output voltage U_{out} (mV) from the heat flux meter from the processed data. After this a best fit should be calculated, using either a linear equation (resulting in A_1 only or in A_1 together with A_0) or a nonlinear approximation (A_0 , A_1 and A_2).

In case the nonlinearity for a certain application is negligible, it can be stated that the nonlinearity during the calibration was negligible, and that therefore a value for A_2 is not given.

Apart from the table and the end result expressed in the constants A_0 , A_1 and A_2 , the calibration certificate should mention the following:

- heat flux meter body temperature during calibration, in °C;
- field of view of the heat flux meter, expressed in degrees. In case of view-limiting apertures, specify field of view from the centre of the sensing surface to the edge of the view-limiting aperture. In case of flat receivers, specify 180°;
- absorptance of coatings
- source temperature, in °C;
- spectral range. In case of window material specify the 50 % transmission points in microns. These are the wavelengths at which the transmission is 50 % of the maximum transmission. In case of black coating without windows, specify 1 µm to 10 µm;
- transmission. In case of window materials, specify the average transmission of the window material if this is known. In case of absence of windows, specify not applicable;
- additional relevant source properties such as vacuum or not;

- uncertainty for each level. The uncertainty estimation should include the uncertainty of the calibration method, the uncertainty emanating from the convective heat transfer, and the uncertainty from the calibration itself.

11 Calibration report

The calibration report should contain the following information:

- a) name and address of the calibrating laboratory;
- b) date and identification number of the report;
- c) name and address of the client;
- d) name, type, serial number, and manufacturer of heat flux meter under calibration, and details of measuring range and absorptance of surface coating;
- e) date of the calibration;
- f) calibration method and calibration range;
- g) identification of the calibration equipment used;
- h) traceability of measurements;
- i) any deviation from the calibration method;
- j) calibration results consisting of a table as described in [Clause 10](#) and a graph showing the calculated radiation as a function of the output signal from the heat flux meter. This function should also be shown as straight line fit;
- k) uncertainty of the test results;
- l) date and signature.

Annex A (normative)

Operating procedure for vacuum black-body cavity method (VBBC) (method 1)

Procedure:

- a) Turn on the bench.
- b) Adjust the black-body temperature to the calibration level.
- c) Prepare the ice point for temperature measurement.
- d) Connect cooling water pipes of the heat flux meter to cooling bath and adjust it to 0,5 kg/min.
- e) Connect output signal of heat flux meter to the voltmeter.
- f) Verify all measuring devices to data loggers.
- g) Run the software.
- h) Switch on the Pirani gauge.
- i) Switch on the primary pump.
- j) Start the signal readings.
- k) Set up the heat flux meter on the holder and then Insert the system in the cavity.
- l) Open the vacuum circuit.
- m) When pressure is lower than 300 Pa, switch on the secondary pump.
- n) Wait until the pressure is approximately 1 Pa.
- o) Start collecting parameter measurements.
- p) Determine the standard deviation of the heat flux meter output over a 4 min period. The system is assumed to be stable when this value is less than 0,1 %.
- q) Stop collecting data.
- r) From each series, an average \bar{U}_i is calculated by software.
- s) Steps n), o), p) and q) are repeated two times at each irradiance level.
- t) Switch off the secondary pump.
- u) Close the vacuum circuit.
- v) Put the cavity at atmospheric pressure.
- w) Remove the heat flux meter, and have a look to the sensor in order to verify that there is no damage.
- x) Increase the black-body temperature to the next irradiance level or go to step z) if the routine is complete.
- y) Measurements are made at about 10 different levels.
- z) All data are stored in a file for analysis.

- aa) Wait for the black-body temperature to stabilize.
- bb) Repeat steps h) to v).
- cc) Remove the heat flux meter from the holder.
- dd) Switch off the software, the cooling bath and all devices running.
- ee) Proceed to data analysis.

.....

Annex B (normative)

Calculating the irradiance from the vacuum black-body cavity (VBBC) to the heat flux meter

B.1 Principle

The cavity is considered as a closed surface Σ , divided into n isothermal surface elements. To calculate the irradiance produced on a given surface, a leaving heat flux method (variant of the net radiation method) is applied. It consists of carrying out an estimation of the heat transfer between the surface elements.

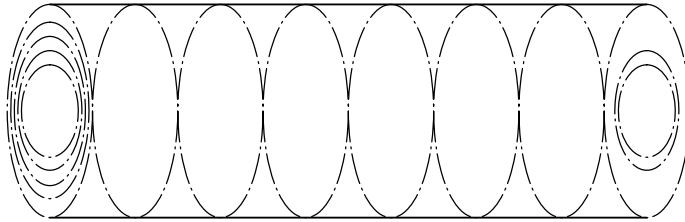

Figure B.1 — Example of surface Σ

For a given surface, S_i :

$$J_i = \varepsilon_i \sigma T_i^4 + (1 - \varepsilon_i) E_i \tag{B.1}$$

where

J_i is the leaving heat flux (radiosity) of surface i , which equals the emitted radiation plus the radiation reflected by surface i ;

ε_i is the emissivity of surface i ;

T_i is the temperature of surface i ;

E_i is the irradiance of surface i ;

$$E_i = \frac{1}{S_i} (J_0 S_0 f_{0,i} + \dots + J_n S_n f_{n,i}) \text{ where } f_{i,j} \text{ is the view factor of surface } i \text{ towards surface } j;$$

$$E_i = \frac{1}{S_i} (J_0 S_0 f_{i,0} + \dots + J_n S_n f_{i,n}) \text{ because } S_i f_{i,j} = S_j f_{j,i};$$

$$E_i = J_0 f_{i,0} + \dots + J_n f_{i,n} \tag{B.2}$$

Thus, the expression (B.1) can be written as

$$J_i = \varepsilon_i \sigma T_i^4 + (1 - \varepsilon_i)(J_0 f_{i,0} + \dots + J_n f_{i,n}) \tag{B.3}$$

Yielding

$$\frac{\varepsilon_i \sigma T_i^4}{1 - \varepsilon_i} = J_0 f_{i,0} + \dots + J_i \left(f_{i,i} - \frac{1}{1 - \varepsilon_i} \right) + \dots + J_n f_{i,n} \tag{B.4}$$

The result is a set of n equations of n unknown quantities, namely the n “radiosities” of the surface elements.

The set of equations is rewritten in the form $FJ = C$ with:

$$F = \begin{bmatrix} f_{0,0} - \frac{1}{1 - \varepsilon_0} & f_{0,1} & \dots & f_{0,n} \\ f_{1,0} & f_{1,1} - \frac{1}{1 - \varepsilon_1} & \dots & f_{1,n} \\ \vdots & \vdots & \ddots & \vdots \\ f_{n,0} & f_{n,1} & \dots & f_{n,n} - \frac{1}{1 - \varepsilon_n} \end{bmatrix} \quad J = \begin{bmatrix} J_0 \\ J_1 \\ \vdots \\ J_n \end{bmatrix} \quad C = \begin{bmatrix} -\frac{\varepsilon_0 \sigma T_0^4}{1 - \varepsilon_0} \\ -\frac{\varepsilon_1 \sigma T_1^4}{1 - \varepsilon_1} \\ \vdots \\ -\frac{\varepsilon_n \sigma T_n^4}{1 - \varepsilon_n} \end{bmatrix}$$

Simply divide by F to find J : $J = F^{-1}C$

The irradiance, E_i , on a particular surface element is obtained from the calculated leaving heat flux (radiosity), using Formula (B.2)

B.2 Modelling of the radiant heat transfer of the VBBC system

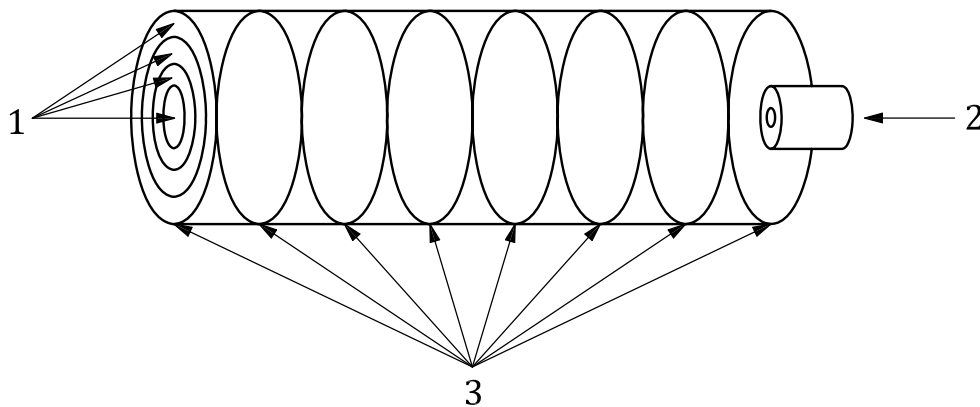

Key

- 1 n rings
- 2 heat flux meter
- 3 k crowns

Figure B.2 — Illustration of the method of splitting the cavity of the black body into isothermal surface elements for the purpose of modelling the radiant heat transfer to the heat flux meter

ISO 14934-2:2013(E)

To simplify calculations of view factors, the following modelling scheme is chosen:

- a) n rings. These rings are each considered as isothermal; with the temperature measured by the thermocouples on each interval;
- b) k crowns constituting the bottom of the cavity considered as isothermal. Their respective temperatures are deduced from the measurements taken by the basic cavity thermocouples;
- c) one disc representing the isothermal sensitive surface of the heat flux meter;
- d) one crown for the reflective diaphragm surrounding the flux meter.

.....

Annex C (informative)

Examples of computer screens for calculating the irradiance from the vacuum black-body cavity (VBBC)

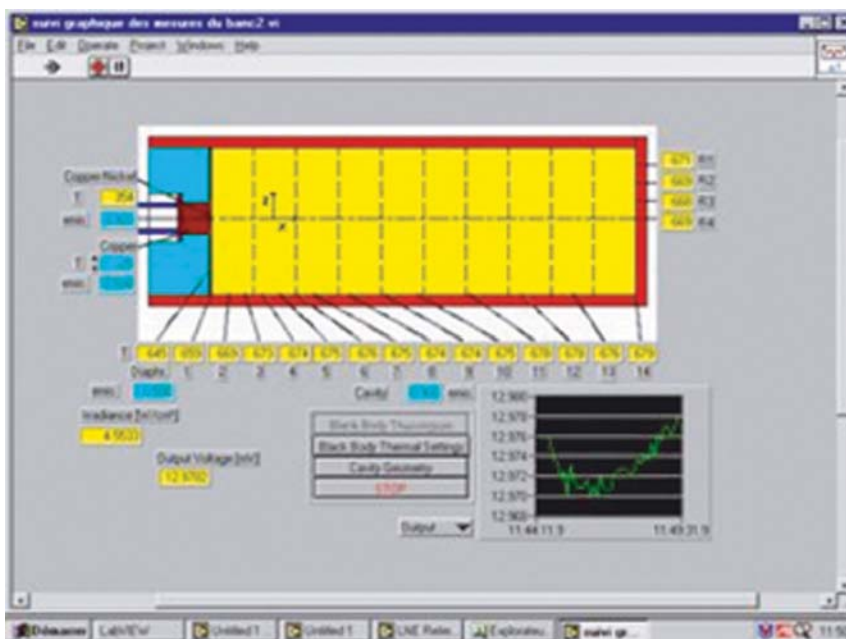

Figure C.1 — Example of temperature gradients along the cavity

Table C.1 — Temperature measurement, probe arrangement for VBBC

Longitudinal position of the probe (Distance from heat flux meter to back of cavity)	Cross position of the probe (Distance from centre of cavity)
mm	mm
0	0
17	27
33	54
50	81
67	—
83	—
100	—
133	—
167	—
200	—
250	—
300	—
350	—
410	—

Annex D (normative)

Operating procedure for spherical black-body cavity method (method 2)

D.1 Stepwise operating instructions

The stepwise operating instructions are listed below

- a) Identify the heat flux meter and enter the following data in the calibration protocol:
- b) manufacturer, type and serial number;
- c) maximum allowable radiation in kW/m².
- d) Decide which 10 radiation levels the heat flux meter is going to be calibrated at. Enter the temperatures corresponding to each radiation level in the protocol. If a fitting piece will be used, note this in the protocol.
- e) Measure the radius of the heat flux meter's receiving sensor and enter this in the protocol. **Be sure to measure only the sensing element.** This could be smaller than the painted area of the heat flux meter.
- f) Choose a suitable fixture for the heat flux meter according to its diameter. Connect water supply and the cables to the data logging system.
- g) Insert the heat flux meter with its fixture into the movable cooler and secure its position.
- h) Measure the depth X_g of the heat flux meter carefully, (distance between top of movable cooler and heat flux meter's receiving sensor) with a 0,01 mm depth gauge and note in the protocol.
- i) Insert the movable cooler into the fixed cooler and secure with lock nuts.
- j) Measure the insert depth if fitting piece is used, with a 0,01 mm depth gauge (may be omitted if fitting piece is very accurate) and note in the protocol.
- k) Connect all measuring devices to data logger.
- l) Turn on cooling water for fixed and movable cooler and for the heat flux meter. The temperature of the water should be approximately 5 °C above room temperature. Adjust the flow of all items.
- m) Water flow for the various items:
- n) fixed part of cooler: 3,3 l/min;
- o) movable part of cooler: 2,5 l/min;
- p) heat flux meter: according to manufacturer of heat flux meter.
- q) Switch on the furnace.
- r) Set the set point temperature corresponding to the first radiation level on the regulator.
- s) Allow furnace to stabilize on the set point temperature, the temperature shall be stable within ± 1 °C/min.
- t) Check cooling water temperature and flow, adjust if necessary.
- u) Take readings during 2 min (approx 120 readings) on stable level.

ISO 14934-2:2013(E)

- v) Repeat steps m) through p) for next level of radiation.
- w) Process the collected data according to the computer code ([Annex E](#)).

Annex E (normative)

Calculating the irradiance from the spherical black-body cavity to the heat flux meter

E.1 Calculation procedure

The incident heat radiation to the gauge is calculated for each measuring point by approximating the cooler as a cylinder according to [Figure E.2](#) and using the net-radiation method:

$$\frac{q_i}{\varepsilon_i} - \sum_{k=1}^5 \frac{1-\varepsilon_k}{\varepsilon_k} F_{ik} q_k = \sum_{k=1}^5 F_{ik} (e_{bi} - e_{bk}) \quad (\text{E.1})$$

where

- q_i is the net heat radiation per unit area leaving the area i ;
 - q_k is the net heat radiation per unit area leaving the area k ;
 - F_{ik} is the view factor for radiation leaving area i and reaching area k ;
 - ε_k is the emissivity for area k ;
 - e_{bi} is the black-body radiation (σT^4) leaving area i .
- area i is defined in [Figure E.1](#).

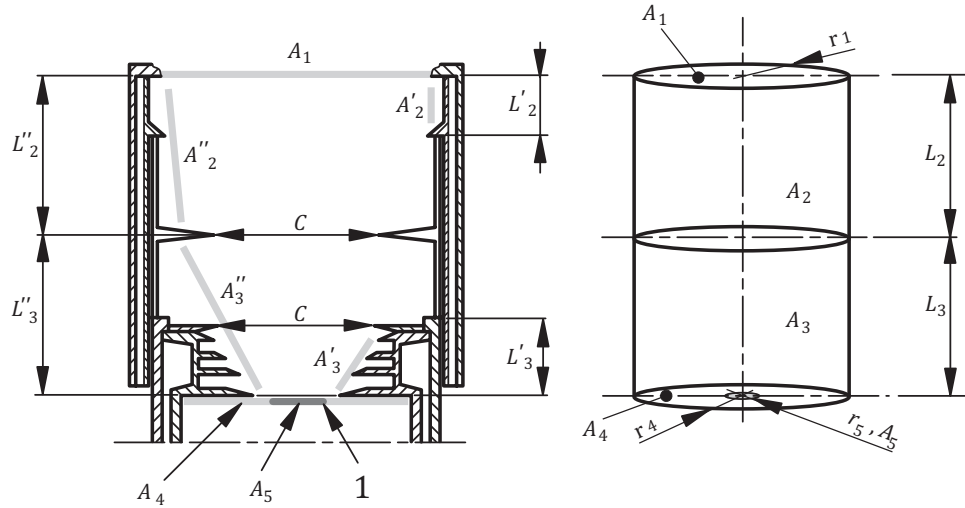

Key

- 1 sensing surface
- A areas
- L heights
- C apertures
- ' with spacer ring
- '' without spacer ring

Figure E.1 — Cylinder approximation of cooler — Left: schematic, Right: model

The calculations are conducted according to the following procedure.

- a) Calculate the apparent emissivity:

$$\epsilon_1 = \frac{1}{1 + \left(\frac{d^2}{4D^2}\right)(1 - \epsilon_f / \epsilon_f)} \tag{E.2}$$

- b) Calculate the viewfactors F_{ij} , $1 \leq i \leq 5$, $1 \leq j \leq 5$ with $F_{11} = F_{44} = F_{55} = F_{45} = F_{54} = F_{25} = F_{52} = 0$.
- c) Calculate the temperature of surfaces A_2 and A_3 .

The temperature of the surfaces depends on the water and furnace temperature. An expression for this relationship needs to be determined for each furnace and cooler by conducting measurements on the cooler surfaces and flanges before taking the furnace in use. Measurements should be conducted according to [Figure E.2](#) and the temperatures be plotted against $\sigma(T_f^4 - T_w^4)$ in order to construct a mean temperature for A_2 and A_3 depending on if the spacer ring is used or not. If no spacer ring is used then A_2 comprises of Thermocouple TC1 and A_3 of Thermocouples TC6 and TC7. If the spacer ring is used then A_2 comprises of Thermocouples TC1, TC2, and TC3, and A_3 of Thermocouples TC4, TC5, TC6 and TC7 as shown in [Figure E.2](#).

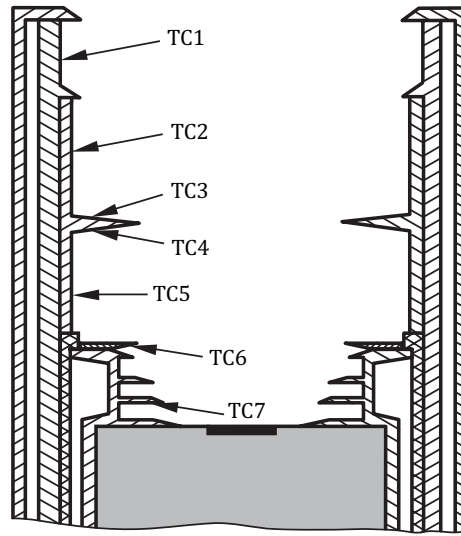

Figure E.2 — Location of thermocouples TC1-TC7 for determining mean temperatures of A_2 and A_3

d) Solve the following equations system:

$$\frac{q_1}{\varepsilon_1} - \frac{1-\varepsilon_2}{\varepsilon_2} F_{12} q_2 - \frac{1-\varepsilon_3}{\varepsilon_3} F_{13} q_3 - \frac{1-\varepsilon_4}{\varepsilon_4} F_{14} q_4 = \sum_1^5 F_{1k} (e_{b1} - e_{bk}) \quad (\text{E.3})$$

$$-\frac{1-\varepsilon_1}{\varepsilon_1} F_{21} q_1 + \frac{1-F_{22}(1-\varepsilon_2)}{\varepsilon_2} q_2 - \frac{1-\varepsilon_3}{\varepsilon_3} F_{23} q_3 - \frac{1-\varepsilon_4}{\varepsilon_4} F_{24} q_4 = \sum_1^5 F_{2k} (e_{b2} - e_{bk}) \quad (\text{E.4})$$

$$-\frac{1-\varepsilon_1}{\varepsilon_1} F_{31} q_1 - \frac{1-\varepsilon_2}{\varepsilon_2} F_{32} q_2 + \frac{1-F_{33}(1-\varepsilon_3)}{\varepsilon_3} q_3 - \frac{1-\varepsilon_4}{\varepsilon_4} F_{34} q_4 = \sum_1^5 F_{3k} (e_{b3} - e_{bk}) \quad (\text{E.5})$$

$$-\frac{1-\varepsilon_1}{\varepsilon_1} F_{41} q_1 - \frac{1-\varepsilon_2}{\varepsilon_2} F_{42} q_2 - \frac{1-\varepsilon_3}{\varepsilon_3} F_{43} q_3 + \frac{q_4}{\varepsilon_4} = \sum_1^5 F_{4k} (e_{b4} - e_{bk}) \quad (\text{E.6})$$

The incident heat radiation is calculated by the equation below using $\varepsilon_5 = 1$ and neglecting the second term on the left hand side since the cooler is designed to prevent reflections from A_1 on A_3 to A_5 .

$$-\frac{1-\varepsilon_1}{\varepsilon_1} F_{51} q_1 - \frac{1-\varepsilon_3}{\varepsilon_3} F_{53} q_3 + \frac{q_5}{\varepsilon_5} = \sum_1^5 F_{5k} (e_{b5} - e_{bk}) \quad (\text{E.7})$$

where

q_i is the net heat radiation per unit area leaving the area i ;

F_{ik} is the view factor for radiation leaving area i and reaching area k ;

ε_k is the emissivity for area k ;

e_{bi} is the black-body radiation (σT^4) leaving area i .

with i and k ranging from 1 to 5 and area 1-5 defined in [Figure E1](#).

Annex F
(normative)

Drawings for the fixed and movable cooler to the spherical black-body cavity

All parts are made of brass. All surfaces visible from the furnace are treated to give a matt black surface with low reflection.

Dimensions in millimetres

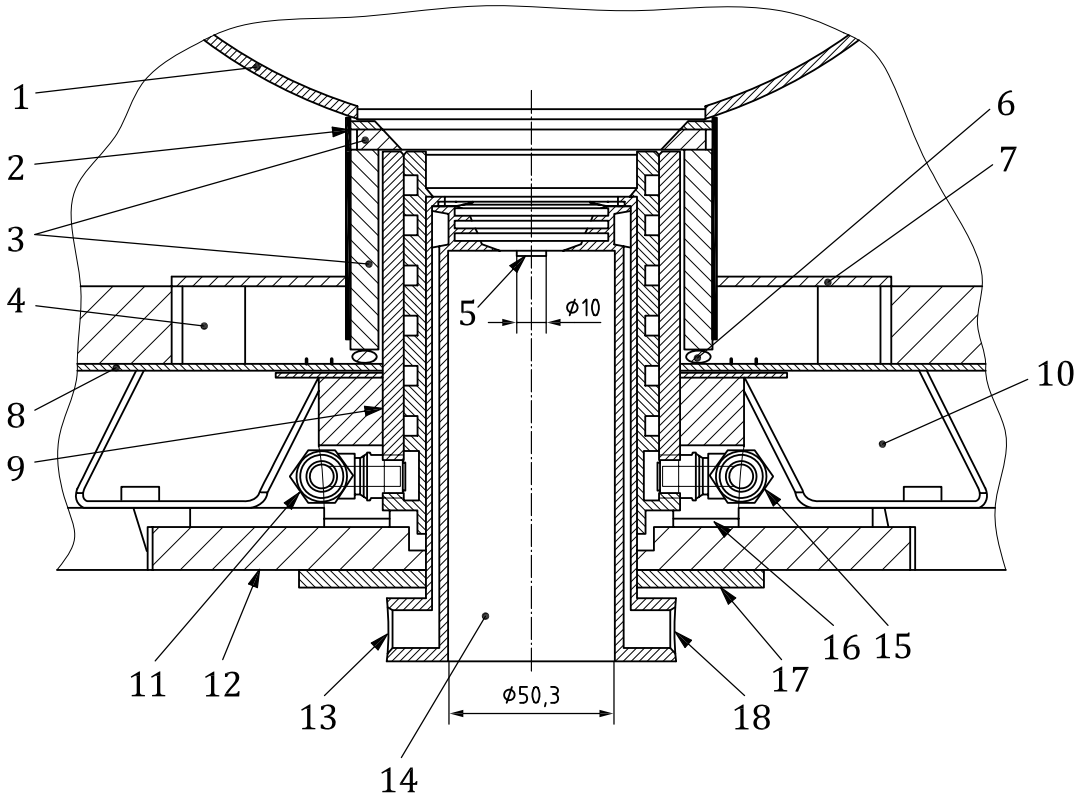

Key

- | | |
|---------------------------------|--|
| 1 spherical cavity emitter | 10 outer ring aperture support |
| 2 inconel spacer ring | 11 water outlet for sight tube |
| 3 ceramic refractory | 12 outside flange |
| 4 refractory posts | 13 water outlet for heat flux meter holder |
| 5 sensing surface | 14 movable, water cooled, heat flux meter holder |
| 6 ultra temperature gasket rope | 15 water inlet for sight tube |
| 7 inner mounting flange | 16 aluminium shim spacer |
| 8 inner shell housing | 17 sight tube mounting flange |
| 9 water cooled sight tube | 18 water inlet for heat flux meter holder |

Figure F.1 — Section showing assembly of spherical cavity, water cooled sight tube, and water cooled heat flux meter holder

Dimensions in millimetres

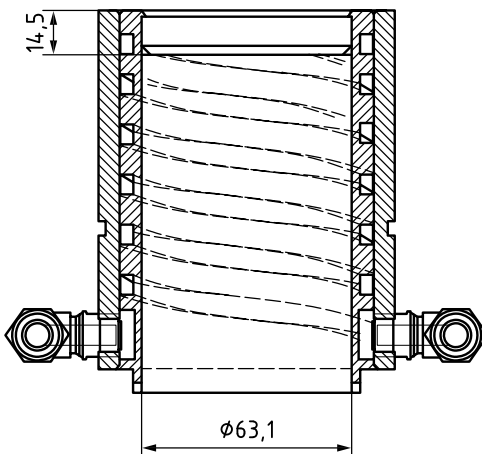

Figure F.2 — Section of water cooled sight tube

Dimensions in millimetres

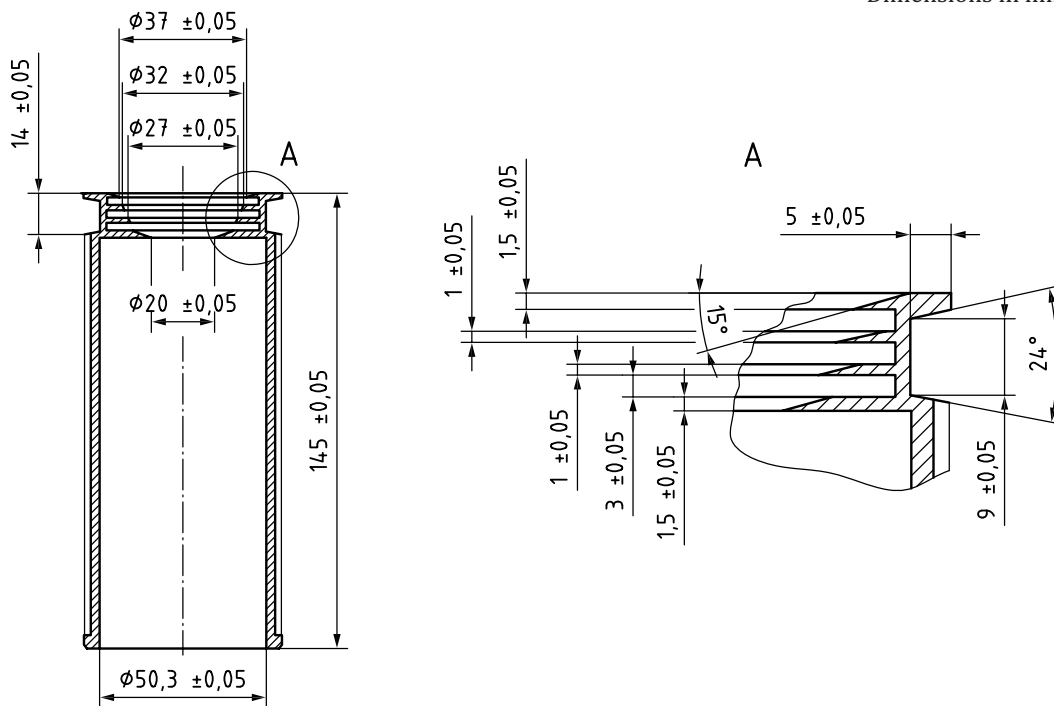

Figure F.3 — Details of flanges on movable, water cooled, heat flux meter holder

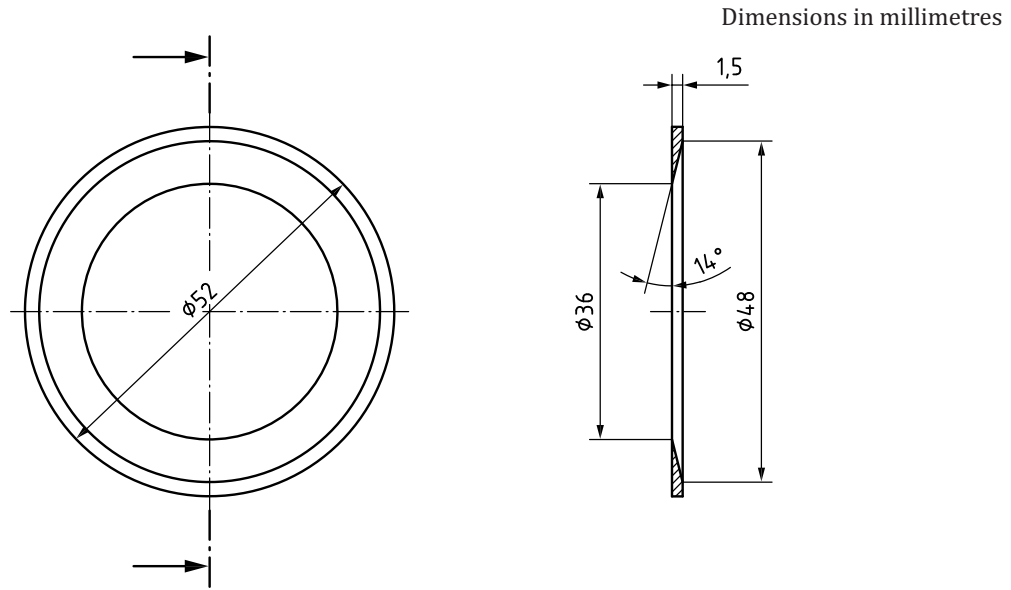

Figure F.4 — Aperture disc

Dimensions in millimetres

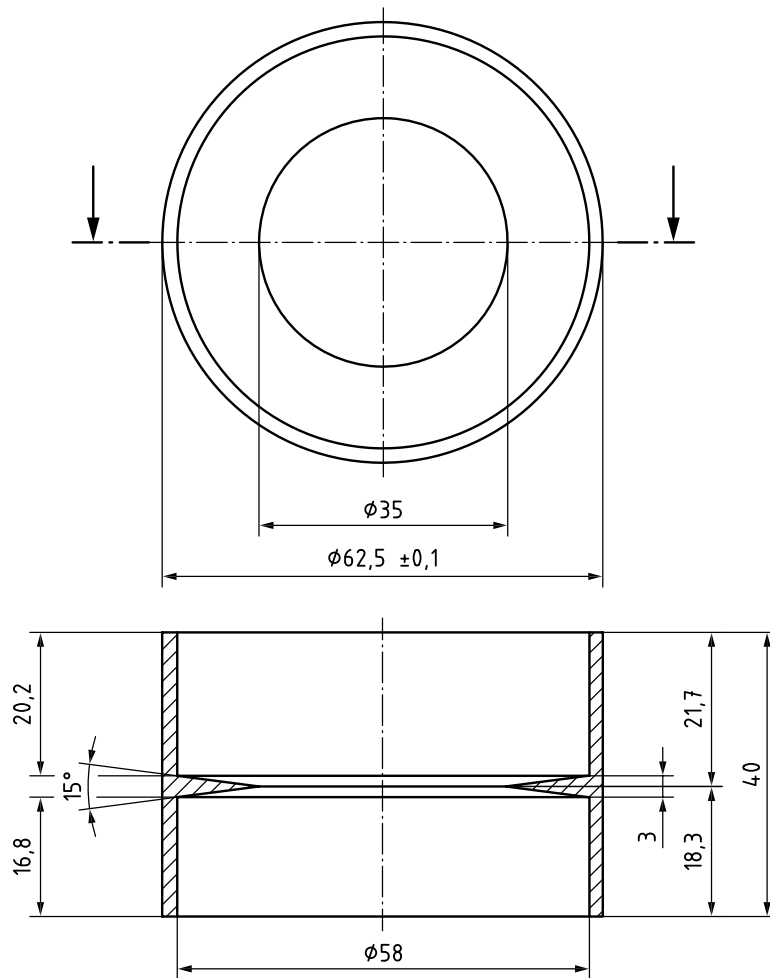

Figure F.5 — Spacer ring

Annex G (informative)

Guidance notes for operators using the spherical black-body cavity method

The furnace can normally be operated between room temperature and 1 100 °C, but it is recommended to use the range 400 °C to 1 000 °C. At lower temperatures the uncertainty increases and at higher temperatures the strain on the furnaces structure increases severely.

Without the spacer ring, i.e. with the movable cooler in its top position, the radiation can be varied between 6 kW/m² and 75 kW/m². With the spacer ring inserted and the cooler in its lowest position, the radiation can be varied between 2 kW/m² and 25 kW/m². Both ranges will allow calibration with a relative inaccuracy of less than 3 % of the calculated radiation level.

The cooling water temperature must be higher than the dew point of the ambient air, in order to avoid condensation of water on the cooler and the heat flux meter. For the heat flux meter itself and its operation, the temperature of the cooling water does not matter too much, but the accuracy of the calibration will be better the lower the water temperature.

Therefore it may be convenient to perform all normal calibrations with a water temperature of 25 °C, as this will be over the dew point in most situations. It is also sufficiently near the normal ambient temperature to minimize the need for corrections with respect to the water temperature when the heat flux meter is used in a real measurement, except for very low flux ranges.

Annex H (normative)

Electrical substitution radiometer (ESR) operating procedure

H.1 Radiometer/controller set-up

The radiometer/controller setup is listed below

- a) Radiometer controller power switch in off-position.
- b) Connect the radiometer controller/signal Bendix cable to the radiometer controller and the controller power cable to the mains.
- c) Cover the radiometer front end with the cap.
- d) Connect the cooling water pump outlet to the inlet of the radiometer.
- e) Connect cooling water pump inlet and the radiometer outlet to the coolant reservoir.
- f) Adjust the dial on the flow controller to give a flow-rate of 0,5 l/m or higher.
- g) Switch on radiometer controller.
- h) Allow about 20 min for stabilization.

H.2 Digital volt meter (DVM) check-out (as and when needed)

The Digital volt meter check-out is performed according to the procedure below

- a) Set switch "S1" to "OPERATE".
- b) Connect a standard voltage source to the BNC input connector.
- c) Set switch "S2" to "ZERO" position.
- d) Turn the DVM's "ZERO" adjust potentiometer to set the read-out to zero.
- e) Set switch "S2" to "SCALE" position.
- f) Turn the DVM's "SCALE" adjust potentiometer to set the read-out to standard voltage source value.

H.3 Dark signal

The Dark signal procedure is performed according to the procedure below

- a) Set both the switches "S1" and "S2" to "OPERATE".
- b) Allow the unit to stabilize for about 20 min.
- c) The steady read-out gives the dark-signal value.
- d) Turn the "TARE (R17)" adjustment potentiometer to set the read-out to 0,000.

H.4 Radiometer self-calibration and operation (See note)

The Radiometer self-calibration and operation procedure is listed below

- a) Set switch "S1" to "SCALE" position (refers to electric heater in use).
- b) Set switch "S2" to "VOLTS" position.
- c) Turn potentiometer "HEATER-R16" to adjust to the desired voltage.
- d) With switch in "S2" in "VOLTS" position, read the voltage " V ", in volts, on the meter.
- e) Set switch "S2" to "CURRENT" position.
- f) Read the heater current, I , in milliamperes, on the meter.
- g) Calculate electrical power $P_c = V \times I \times C_f$.
- h) where C_f is the radiometer aperture area, in square centimetres; For the radiometer in use, $C_f = 0,9925$.
- i) Set switch "S2" to "OPERATE" position.
- j) Allow the read-out to stabilize.
- k) Note down the indicated power, P_i , on the meter.
- l) If P_i is not equal to P_c , turn potentiometer "SCALE (R18)" to set read-out P_i , to P_c .
- m) Set both the switches "S1" and "S2" to "OPERATE" position.

NOTE The radiometer is self-calibrated at a power level of about 920 mW to be consistent with calibration in the laser facility. The heat flux value is calculated using the radiometer's actual calibration.

Annex I (normative)

Procedure for heat flux meter calibration using the 25-mm VTBB method (method 3)

I.1 Calibration set-up

The Calibration set-up is listed below

- a) Remove the standard graphite tube extension on the viewing end of the VTBB and replace it with the short extension.
- b) Locate/align the reference ESR and the test sensor at a fixed distance from the exit of the VTBB using standard gauge blocks²⁾.
- c) Note down position values for the positioning-stage on which the VTBB is mounted, corresponding to the ESR (station 1) and the test sensor (station 2).
- d) Identify another position (station 3) away from the ESR and the sensor, to station VTBB while being heated or cooled.
- e) Make cooling water pump connection to the ESR and set the flow-rate to 0,5 l/min or higher.
- f) If the sensor to be calibrated is of the water-cooled type, make appropriate cooling arrangements as per the manufacturer's specification.
- g) If the sensor is not water cooled, connect the body temperature thermocouple leads to the Fluke thermometer to monitor body temperature during testing.
- h) Connect the radiometer control analogue output to the digital volt meter (channel 1).
- i) Connect the sensor signal output to the digital volt meter (channel 2).
- j) Check all the connections, signal polarity and instrument cooling for proper functioning.
- k) Record dark signals for the ESR and test sensor for about 60 s.

I.2 Calibration measurements

The Calibration measurements is listed below

- a) Record laboratory temperature and humidity.
- b) Locate the VTBB at station 3.
- c) Turn on the black-body and bring up to the desired temperature (see [Table 3](#)) following the standard procedure for the black-body operation in the laboratory.
- d) Allow the temperature to stabilize.
- e) Move the VTBB in front of the ESR located at station 1.
- f) Allow about 60 s for the ESR readings to stabilize.

2) Recommended location: 12,5 mm (up to 50 kW/m²), 62,5 mm (up to 25 kW/m²), and 140 mm (up to 10 kW/m²).

ISO 14934-2:2013(E)

g) Record ESR output for about 20 s to 60 s depending on the heat flux level³⁾.

NOTE Use a convenient file name to store the radiometer and sensor output data for later analysis.

h) Move the VTBB to station 2 in front of the test sensor.

i) If the sensors are not water-cooled, go to step l).

j) For water-cooled sensors, record the sensor output for about the same duration as for ESR.

k) Go to step m).

l) Data taking duration will be limited by the sensor body-temperature rise with test time. Monitor body temperature rise when exposing to radiant heat flux. The exposure duration is limited to about 10 s or less at high heat-flux levels corresponding to sensor location of 12,5 mm from the black-body exit.

m) Move the VTBB to station 3.

n) Increase the temperature to the next value.

o) Follow steps d) to m) for other heat flux levels.

p) At the end of program, move the VTBB to station 3.

q) Shut down black-body following standard procedure in the laboratory.

r) Remove the radiometer and the test sensor from the setup and inspect.

3) > 60 s at 10 kW/m²; 20 s or lower at 50 kW/m²; for sensor location at 12,5 mm. 10 s to 20 s for other location.

Annex J (normative)

Data reduction procedure for the VTBB method (method 3)

The data reduction procedure is listed below

- a) the mean value of the radiometer output (E_I) in kW/m², and the test-sensor output (V) from the data for each temperature setting of the black-body.
- b) Subtract the dark signals from the mean values calculated in step a). For calibration under high heat-flux conditions, the dark signals are small compared to the signal levels.
- c) Calculate statistical quantities of interest such as standard deviation of the mean, from the output readings of radiometer and the sensor to include in measurement uncertainty.
- d) Convert the indicated radiometer mean value (E_I) to corrected power at the ECR (E_C) by using the correction factor ($E_C = 0,985\ 5 \times E_I$), and express the sensor output, expressed in millivolts.
- e) Perform a linear regression analysis for the heat flux (E_C) and the sensor output, expressed in millivolts. The slope of the linear regression gives the responsivity of the sensor in mV/(kW/m²). [Figure J.1](#) shows a typical calibration plot for the reference Schmidt-Boelter sensor.
- f) Calculate measurement uncertainty in the calibration as listed in [Table 4](#).

NOTE For calculation of mean values and other statistical quantities, a spreadsheet or a statistical software can be used.

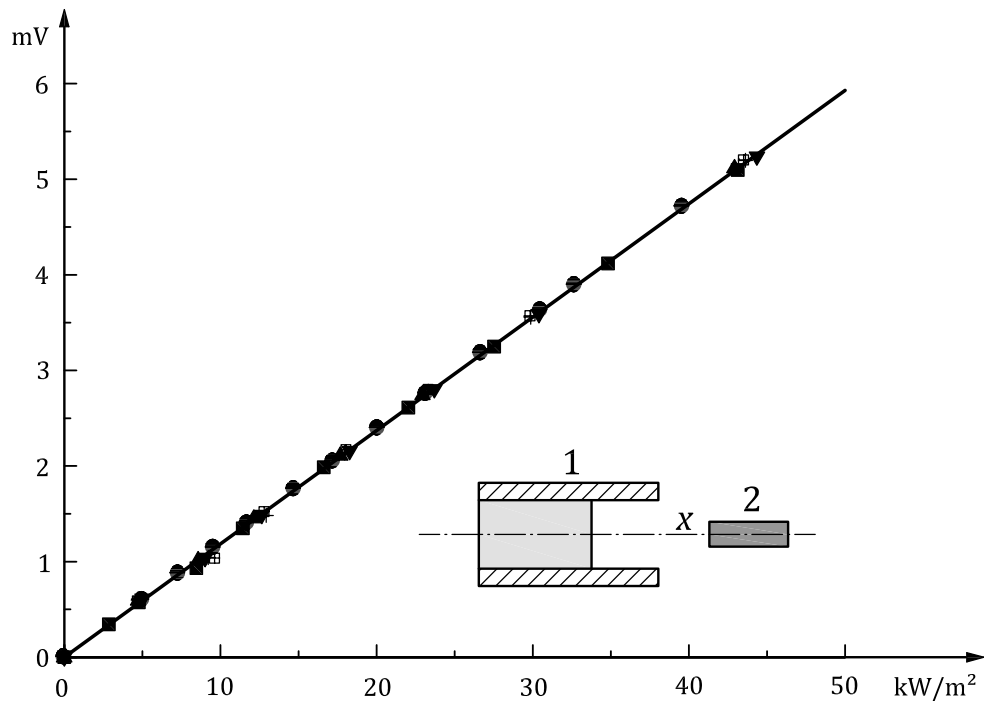

Key

- 1 black-body
- 2 gauge

NOTE x = distance between the black-body exit and the sensor.

Figure J.1 — Results of repeat calibrations on the reference Schmidt-Boelter sensor in the 25 mm variable-temperature black-body method (method 3)

Annex K (informative)

Precision of calibration

A Round-Robin utilizing the three methods described in this part of ISO 14934 was conducted in 2008-2010^[12]. The RR was conducted using three meters at 10 levels. A linear regression was applied to the calibration result of each meter and method which resulted in a $\pm 4\%$ variation at the 10 mV level.

.....

Bibliography

- [1] IEC 60050-845:1987, *International Electrotechnical Vocabulary. Lighting*
- [2] ISO 31-6:1992⁴⁾, *Quantities and units — Part 6: Light and related electromagnetic radiations*
- [3] Filtz, J.-R., *Note on primary calibration of heat flux meters* - March 2000, Annex to ISO/TC 92 /SC1 N607
- [4] Filtz J.-R., Lièvre M., Valin T., Lemonnier D., Blay D. *A vacuum blackbody cavity for radiometric calibration of Gardon Gauges* – International Metrology Congress – Saint Louis, France (2001)
- [5] Olsson S. *Calibration of Radiant Heat Flux Meters — The development of a Water Cooled Aperture for Use with Black Body Cavities*. Nordtest Project 873-90. SP REPORT 1991:58, National Testing and Research Institute, SP, Sweden, 1992. ISBN 91-7848-317-4
- [6] *The International Temperature Scale of 1990 (ITS-90)*. Sèvres, BIPM, 1990. Metrologia, 1990, vol. 27, pp. 3-10 and 107
- [7] Murthy A.V., Tsai B.K. *Transfer calibration of heat flux sensors at NIST*, HTD-Vol. 345, *ASME proceedings of the National Heat Transfer Conference*, Edited by Kaminski, D., Smith, A.M., and Smith, T.F., 7, pp. 81-88 (1997)
- [8] GENTILE T.T., HOUSTON J.M., HARDIS J.E., CROMER C.L., PARR A.C. The NIST high accuracy cryogenic radiometer. *Appl. Opt.* 1996, 35 pp. 1056–1068
- [9] MURTHY A.V., TSAI B.K., GIBSON C.E. Calibration of high heat flux sensors. *J. Res. Natl. Inst. Stand. Technol.* 1997, 102 (4) pp. 479–488
- [10] MURTHY A.V., TSAI B.K., SAUNDERS R.D. Aperture proximity effects in high heat flux sensors calibration. *J. Res. Natl. Inst. Stand. Technol.* 1998, 103 (6) pp. 621–624
- [11] Andersson P., Wetterlund I. *Uncertainty in heat flux calibrations performed according to NT FIRE 050* Nordtest project No. 1525-01 SP REPORT 2001:34, National Testing and Research Institute, SP, Sweden, 2001. ISBN 91-7848-882-6
- [12] Andersson P., Wetterlund I. *Round Robin of Primary Calibration of Heat Flux meters*, SP Technical Note 2011:05, SP Technical Research Institute of Sweden, Sweden, 2011

4) Withdrawn and replaced by ISO 80000-7:2008.

Vertical line of dots on the right side of the page.

ICS 13.220.50,13.220.40

Price based on 46 pages