**Ophthalmic optics — Spectacle
lenses — Fundamental requirements
for uncut finished lenses**

*Optique ophtalmique — Verres de lunettes — Exigences
fondamentales relatives aux verres finis non détourés*



Reference number
ISO 14889:2013(E)

© ISO 2013



COPYRIGHT PROTECTED DOCUMENT

© ISO 2013

All rights reserved. Unless otherwise specified, no part of this publication may be reproduced or utilized otherwise in any form or by any means, electronic or mechanical, including photocopying, or posting on the internet or an intranet, without prior written permission. Permission can be requested from either ISO at the address below or ISO's member body in the country of the requester.

ISO copyright office
Case postale 56 • CH-1211 Geneva 20
Tel. + 41 22 749 01 11
Fax + 41 22 749 09 47
E-mail copyright@iso.org
Web www.iso.org

Published in Switzerland

Contents

	Page
Foreword	iv
1 Scope	1
2 Normative references	1
3 Terms and definitions	1
4 Fundamental requirements for spectacle lenses	1
4.1 Performance	1
4.2 Design	1
4.3 Materials	2
4.4 Mechanical strength	2
4.5 Transmittance	2
5 Test methods	3
5.1 General	3
5.2 Inflammability	3
5.3 Test for mechanical strength	3
6 Identification	5
6.1 Identification of the spectacle lens to be stated on the package of each individual spectacle lens or in an accompanying document	5
6.2 Information to be made available	6

Foreword

ISO (the International Organization for Standardization) is a worldwide federation of national standards bodies (ISO member bodies). The work of preparing International Standards is normally carried out through ISO technical committees. Each member body interested in a subject for which a technical committee has been established has the right to be represented on that committee. International organizations, governmental and non-governmental, in liaison with ISO, also take part in the work. ISO collaborates closely with the International Electrotechnical Commission (IEC) on all matters of electrotechnical standardization.

The procedures used to develop this document and those intended for its further maintenance are described in the ISO/IEC Directives, Part 1. In particular the different approval criteria needed for the different types of ISO documents should be noted. This document was drafted in accordance with the editorial rules of the ISO/IEC Directives, Part 2. www.iso.org/directives

Attention is drawn to the possibility that some of the elements of this document may be the subject of patent rights. ISO shall not be held responsible for identifying any or all such patent rights. Details of any patent rights identified during the development of the document will be in the Introduction and/or on the ISO list of patent declarations received. www.iso.org/patents

Any trade name used in this document is information given for the convenience of users and does not constitute an endorsement.

The committee responsible for this document is ISO/TC 172, *Optics and photonics*, Subcommittee SC 7, *Ophthalmic optics and instruments*.

This third edition cancels and replaces the second edition (ISO 14889:2003), [subclauses 4.1](#), [4.4](#), [4.5.1](#) and [4.5.2](#) of which have been technically revised.



Ophthalmic optics — Spectacle lenses — Fundamental requirements for uncut finished lenses

1 Scope

This International Standard specifies fundamental requirements for uncut finished spectacle lenses. This International Standard is not applicable to protective spectacle lenses.

This International Standard takes precedence over the corresponding requirements of other standards, if differences exist.

2 Normative references

The following documents, in whole or in part, are normatively referenced in this document and are indispensable for its application. For dated references, only the edition cited applies. For undated references, the latest edition of the referenced document (including any amendments) applies.

ISO 8980-1, *Ophthalmic optics — Uncut finished spectacle lenses — Part 1: Specifications for single-vision and multifocal lenses*

ISO 8980-2, *Ophthalmic optics — Uncut finished spectacle lenses — Part 2: Specifications for progressive power lenses*

ISO 8980-3:2013, *Ophthalmic optics — Uncut finished spectacle lenses — Part 3: Transmittance specifications and test methods*

ISO 8980-4, *Ophthalmic optics — Uncut finished spectacle lenses — Part 4: Specifications and test methods for anti-reflective coatings*

ISO 13666, *Ophthalmic optics — Spectacle lenses — Vocabulary*

ISO 21987, *Ophthalmic optics — Mounted spectacle lenses*

3 Terms and definitions

For the purposes of this document, the terms and definitions given in ISO 13666 and the following apply.

3.1

manufacturer (of an uncut finished spectacle lens)

natural or legal person who places the uncut finished lens on the market

4 Fundamental requirements for spectacle lenses

4.1 Performance

In addition to the requirements specified in this International Standard, uncut finished lenses shall comply with the relevant parts of ISO 8980, and mounted lenses shall comply with ISO 21987.

4.2 Design

Spectacle lenses shall be designed so that the overall risk associated with their use according to the conditions intended by the manufacturer, relative to the risk when the spectacle lenses are not used, is

reduced to a level consistent with the materials used and compatible with the generally acknowledged state-of-the-art.

4.3 Materials

4.3.1 Physiological compatibility

Lenses shall not be made from materials known to be physiologically incompatible or known to create allergic or toxic reactions among a significant proportion of wearers when the lenses are used as intended by the manufacturer.

4.3.2 Inflammability

When the lens is tested as described in [5.2](#), there shall be no continued combustion after withdrawal of the test rod.

4.4 Mechanical strength

Uncut spectacle lenses shall withstand the quasi-static loading type test for minimum robustness described in [5.3](#).

The requirement for minimum robustness shall be satisfied if the spectacle lens withstands the application of a 22 mm diameter steel ball with a force of (100 ± 2) N, when tested as described in [5.3](#).

This test shall be carried out immediately after conditioning at a temperature of (23 ± 5) °C.

After this test, the following defects shall not be apparent:

a) Lens fracture.

A spectacle lens shall be considered to have fractured if it has cracked through its entire thickness into two or more pieces or if more than 5 mg of the lens material has become detached from the surface.

b) Lens deformation.

A spectacle lens shall be considered to have been deformed if a mark has appeared on the white paper underneath the lens.

NOTE If the spectacle lens is intended for use for industrial or other purposes where mechanical hazards exist, a higher level of mechanical strength or robustness may be required. If eye protection is required, the specific requirements are given in the appropriate International Standard.

4.5 Transmittance

4.5.1 General requirements

The transmittance shall conform to the requirements specified in ISO 8980-3:2013, 6.1. and 6.2.

4.5.2 Additional requirements for lenses intended for road use and driving

4.5.2.1 General

The transmittance shall conform to the requirements specified in ISO 8980-3:2013, 6.3.1.

4.5.2.2 Spectral transmittance

The transmittance shall conform to the requirements specified in ISO 8980-3:2013, 6.3.2.

4.5.2.3 Daylight use

The transmittance shall conform to the requirements specified in ISO 8980-3:2013, 6.3.3.

4.5.2.4 Driving in twilight or at night

The transmittance shall conform to the requirements specified in ISO 8980-3:2013, 6.3.4.

4.5.2.5 Relative visual attenuation coefficient (quotient) for recognition/detection of incandescent signal lights

The relative visual attenuation coefficient (quotient) shall conform to the requirements specified in ISO 8980-3:2013, 6.3.5.

5 Test methods

5.1 General

All tests described in this International Standard are type tests.

5.2 Inflammability

5.2.1 Apparatus

The test device consists of a steel rod (300 ± 3) mm long and 6 mm nominal diameter, with a flat end face perpendicular to its longitudinal axis, a heat source and a thermocouple with a temperature-indicating device.

5.2.2 Procedure

Heat one end of the steel rod over a length of at least 50 mm to a temperature of (650 ± 20) °C. Measure the temperature of the rod by means of the thermocouple attached at a distance of (20 ± 1) mm from the heated end of the rod.

With the rod positioned with its axis vertical, allow the heated face of the rod to rest under its own weight on the surface of the test sample for a period of not less than 5 s, and then remove the rod.

Repeat this test on a sample lens made from each material to be used. Carry out visual inspection to establish whether combustion continues after removal of the rod from the test sample.

5.3 Test for mechanical strength

5.3.1 Apparatus (see [Figure 1](#))

5.3.1.1 Loading device

A steel ball of 22 mm nominal diameter is fastened to the lower end of a tube, the nominal length of which is 70 mm. The loading mass shall be such that the force acting on the test specimen is (100 ± 2) N.

5.3.1.2 Specimen support

The specimen support consists of a steel supporting plate and a pressure ring. The upper face of the steel supporting plate and the lower face of the pressure ring are, by appropriate means, each fitted with a circular silicone rubber ring of (40 ± 5) IRDH having an inside diameter of $(35 \pm 0,1)$ mm and a nominal cross section of 3 mm × 3 mm.

If the specimen lens is of insufficient dimensions to enable its entire periphery to be adequately supported, a suitable adaptor sleeve shall be used.

The pressure ring has a mass of (250 ± 5) g.

NOTE 1 This pressure ring is necessary to ensure that the silicone seating presses securely against the upper surface of the specimen.

A sheet of carbon paper on top of a sheet of white paper is placed on the plane base of a cylindrical cavity in the supporting plate. The plane base of the cavity is located 1,5 mm below the surface to which the silicone ring is attached (assumed as being plane in this case), and parallel to it. In those cases where a supporting plate is designed to support a lens surface that is not rotationally symmetrical and therefore has a three-dimensional upper face to carry the silicone ring (see [5.3.2.2](#)), the distance of 1,5 mm is measured from the lowest point of the edge of the cavity to the plane base of it.

NOTE 2 An alternative method may be used (e.g. a mechanical sensor to measure deformation) if shown to be equivalent.

5.3.2 Procedure

5.3.2.1 Preparation

Carry out the test at the temperature specified in [4.4](#).

5.3.2.2 Positioning of the specimen

Centre the specimen on the support with the back surface downwards and place the pressure ring centrally on the specimen with its silicone rubber ring face down.

NOTE For lenses with other than rotationally symmetrical back surfaces, the supporting plate should be curved to conform to the lens back surfaces.

5.3.2.3 Application of the load

Lower the loading mass on to the lens at a speed not exceeding 400 mm/min. Maintain the force of (100 ± 2) N for (10 ± 2) s then remove the loading mass.

Dimensions in millimetres

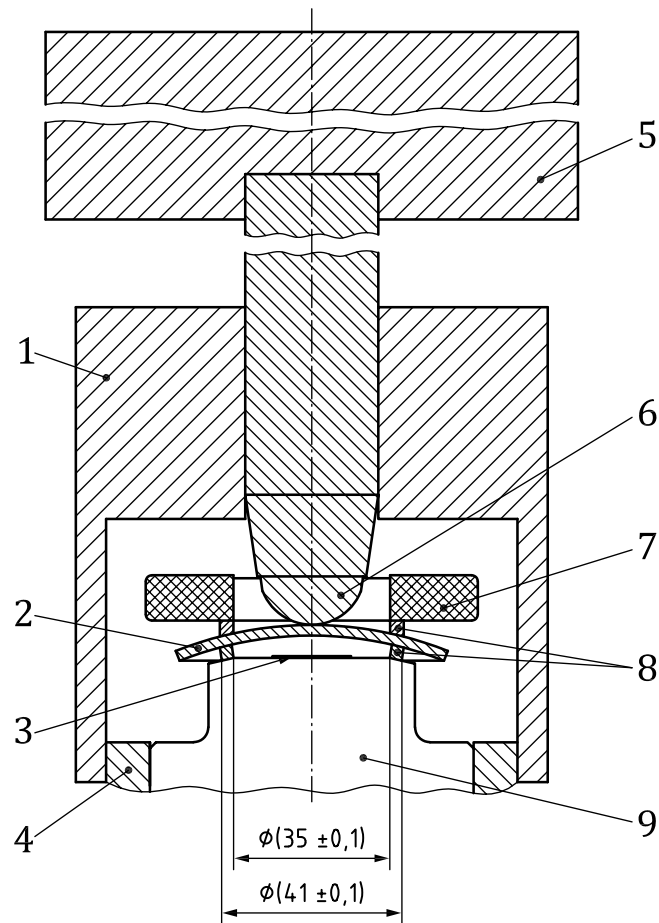
**Key**

- 1 guiding block
- 2 spectacle lens
- 3 carbon paper on white paper
- 4 centring ring
- 5 loading mass (100 ± 2) N
- 6 steel ball
- 7 pressure ring (250 ± 5) g
- 8 silicone seating rings ($35 \times 3 \times 3$) mm
- 9 support system

Figure 1 — Apparatus for minimum robustness test**6 Identification****6.1 Identification of the spectacle lens to be stated on the package of each individual spectacle lens or in an accompanying document**

6.1.1 At least the following information shall be stated for all spectacle lenses:

- a) dioptric power, in dioptres;
- b) nominal size, in millimetres;

ISO 14889:2013(E)

- c) colour, if the lens has noticeable colour in transmission;
- d) identification of any coating;
- e) manufacturer's or supplier's tradename or equivalent;
- f) material tradename, or refractive index or equivalent;
- g) "as-worn" corrected dioptric power, if applicable.

NOTE Corrected values for focal, prismatic and addition power occur when corrections are made, e.g. for the "as-worn" position.

6.1.2 The following additional information shall be stated for multifocal lenses:

- a) addition power;
- b) segment dimensions, in millimetres;
- c) prismatic effect of the prism segment, if any;
- d) an indication stating right lens or left lens, if applicable;
- e) style designation or tradename;
- f) method for addition power measurement, if not the front surface method;
- g) location of the distance reference point for aspheric multifocal lenses.

6.1.3 The following additional information shall be stated for progressive-power lenses:

- a) addition power;
- b) an indication stating right lens or left lens;
- c) style designation or tradename;
- d) method for addition power measurement, if not the front surface method.

6.2 Information to be made available

6.2.1 The following information shall be made available on request for all spectacle lenses:

- a) centre or edge thickness, in millimetres;
- b) optical properties (including Abbe number and spectral transmittance);
- c) density of the material.

6.2.2 If applicable, the following additional information shall be made available on request for multifocal and progressive-power lenses:

- a) the base curve or distance portion curve, in dioptres or millimetres;
- b) the prism thinning, if applicable;
- c) centration chart for re-marking the positions of the non-permanent markings from those of the permanent markings.

www.iso.org/iso/14889