**Implants for surgery — Total knee-joint
prostheses**

**Part 1:
Determination of endurance properties of
knee tibial trays**

Implants chirurgicaux — Prothèses totales de l'articulation du genou

*Partie 1: Détermination des propriétés d'endurance des tablettes tibiales du
genou*



Reference number
ISO 14879-1:2000(E)

© ISO 2000

PDF disclaimer

This PDF file may contain embedded typefaces. In accordance with Adobe's licensing policy, this file may be printed or viewed but shall not be edited unless the typefaces which are embedded are licensed to and installed on the computer performing the editing. In downloading this file, parties accept therein the responsibility of not infringing Adobe's licensing policy. The ISO Central Secretariat accepts no liability in this area.

Adobe is a trademark of Adobe Systems Incorporated.

Details of the software products used to create this PDF file can be found in the General Info relative to the file; the PDF-creation parameters were optimized for printing. Every care has been taken to ensure that the file is suitable for use by ISO member bodies. In the unlikely event that a problem relating to it is found, please inform the Central Secretariat at the address given below.

© ISO 2000

All rights reserved. Unless otherwise specified, no part of this publication may be reproduced or utilized in any form or by any means, electronic or mechanical, including photocopying and microfilm, without permission in writing from either ISO at the address below or ISO's member body in the country of the requester.

ISO copyright office
Case postale 56 • CH-1211 Geneva 20
Tel. + 41 22 749 01 11
Fax + 41 22 734 10 79
E-mail copyright@iso.ch
Web www.iso.ch

Printed in Switzerland

Contents

Page

Foreword.....	iv
1 Scope	1
2 Normative references	1
3 Terms and definitions	1
4 Principle.....	2
5 Apparatus	2
6 Procedure	3
7 Test report	4
8 Disposal of test specimens	4
Bibliography	7

Foreword

ISO (the International Organization for Standardization) is a worldwide federation of national standards bodies (ISO member bodies). The work of preparing International Standards is normally carried out through ISO technical committees. Each member body interested in a subject for which a technical committee has been established has the right to be represented on that committee. International organizations, governmental and non-governmental, in liaison with ISO, also take part in the work. ISO collaborates closely with the International Electrotechnical Commission (IEC) on all matters of electrotechnical standardization.

International Standards are drafted in accordance with the rules given in the ISO/IEC Directives, Part 3.

Draft International Standards adopted by the technical committees are circulated to the member bodies for voting. Publication as an International Standard requires approval by at least 75 % of the member bodies casting a vote.

Attention is drawn to the possibility that some of the elements of this part of ISO 14879 may be the subject of patent rights. ISO shall not be held responsible for identifying any or all such patent rights.

International Standard ISO 14879-1 was prepared by Technical Committee ISO/TC 150, *Implants for surgery*, Subcommittee SC 4, *Bone and joint replacements*.

ISO 14879 consists of the following part, under the general title *Implants for surgery — Total knee-joint prostheses*:

— *Part 1: Determination of endurance properties of knee tibial trays*

© ISO 2000

Implants for surgery — Total knee-joint prostheses —

Part 1:

Determination of endurance properties of knee tibial trays

1 Scope

This part of ISO 14879 specifies a test method for determining the endurance properties, under specified laboratory conditions, of tibial trays used in knee-joint prostheses to support and secure the plastics articulating surface. It applies to tibial trays which cover both the medial and lateral plateaux of the tibia.

The test method does not apply to tibial components manufactured solely from plastics materials.

This part of ISO 14879 does not cover methods of examining and reporting the final condition of the test specimen; these may be the subject of agreement between the test laboratory and the parties submitting the specimen for test.

2 Normative references

The following normative documents contain provisions which, through reference in this text, constitute provisions of this part of ISO 14879. For dated references, subsequent amendments to, or revisions of, any of these publications do not apply. However, parties to agreements based on this part of ISO 14879 are encouraged to investigate the possibility of applying the most recent editions of the normative documents indicated below. For undated references, the latest edition of the normative document referred to applies. Members of ISO and IEC maintain registers of currently valid International Standards.

ISO 4965:1979, *Axial load fatigue testing machines — Dynamic force calibration — Strain gauge technique.*

ISO 7207-1:1994, *Implants for surgery — Components for partial and total knee-joint prostheses — Part 1: Classification, definitions and designation of dimensions.*

3 Terms and definitions

For the purposes of this part of ISO 14879, the terms and definitions given in ISO 7207-1 apply, together with the following.

3.1

anteroposterior centreline

line which passes through the centre of the tibial tray, parallel to the sagittal

3.3

mediolateral centreline

line which passes through the centre of the tibial tray, parallel to the coronal, or frontal, plane

**3.4
moment arm**

d_{ml}
perpendicular distance between the anteroposterior centreline of the tibial component and the axis of load application

NOTE The distance is positive if the loading point is posterior to the centreline.

**3.5
moment arm**

d_{ap}
perpendicular distance between the mediolateral centreline of the tibial component and the axis of load application

4 Principle

The test specimen is placed in a test rig and fixed so that one condyle of the tray extends as a cantilever. A cyclic load is applied to the unsupported condyle through an ultra-high molecular weight polyethylene (PE-UHMW) spacer. The cyclic load is applied until the test specimen exhibits failure or until the chosen number of cycles has been attained. The specimen is examined for defects caused by the loading.

5 Apparatus

5.1 Testing machine, with the following characteristics:

- a) a sinusoidal dynamic-loading waveform or, if not sinusoidal, a smooth waveform with no overshoots;
- b) an error in applied load not greater than $\pm 2\%$ at the maximum load (in accordance with ISO 4965);
- c) instrumentation to maintain the values of the maximum and minimum loads on the tibial tray test specimen to an accuracy of $\pm 2\%$, and to stop the test if these loads differ from their specified values by more than $\pm 2\%$;
- d) instrumentation to record the number of cycles.

5.2 Means of fixing the test specimen, to allow:

- a) the test specimen to be held as a cantilever beam;
- b) fixing the inferior surface or clamping the superior surface of the unsupported test specimen tray away from the mid-line;

NOTE Epoxy resin or bone cement (see for information ISO 5833) may be used as an embedding material.

- c) the tibial tray to be supported up to the centreline (see Figures 1 and 2). If the tray includes a central stem or other prominence on the inferior surface, these shall be supported in the same manner.
- d) the load axis to be perpendicular to the undeflected superior surface of the test specimen.

5.3 Ultra-high molecular weight polyethylene spacer, to be placed between the test specimen and the load applicator to distribute the loading and reduce fretting.

The spacer shall have a diameter of $13\text{ mm} \pm 0,5\text{ mm}$ and a thickness at the rim of $6\text{ mm} \pm 0,5\text{ mm}$. The spacer diameter and/or shape may be modified to accommodate the tibial tray design being tested, but any deviations from these specified dimensions shall be included in the test report.

NOTE Material in accordance with grade 1 or grade 2 of ISO 5834-2 has been found suitable.

5.4 Load applicator, a rod of diameter $32 \text{ mm} \pm 1 \text{ mm}$ with a spherical indenter end.

It is recommended that the indenter be manufactured from a steel or cobalt-chrome alloy.

NOTE The load applicator may be modified to accommodate aspects of the tray design, such as a rim around the periphery.

6 Procedure

6.1 Determine the overall mediolateral and anteroposterior dimensions in accordance with ISO 7207-1:1994, Figures 2 and 3.

6.2 Fix the test specimen in the test rig in accordance with 5.2 c). If the test specimen is asymmetrical, ensure that it is fixed so that the bending moment is a maximum at the junction of the tray with the stem, or at the division between the medial and lateral compartments if no stem is present. Ensure that there is a clearance of at least 5 mm between the undersurface of the loaded compartment on the tibial tray and any part of the fixture. Ensure that the loaded part of the tibial tray does not make contact with any part of the fixture during testing.

6.3 Position the test specimen so that the load axis is perpendicular to the undeflected superior surface of the tray.

NOTE 1 The tray surface will not remain perpendicular to the load axis during loading.

NOTE 2 The loading point will be located at a distance d_{ml} from the anteroposterior and d_{ap} from the mediolateral centreline in the position where it is expected to be loaded *in vivo* at 0° flexion.

6.4 Use one of the following methods to determine the position of the loading point.

- a) **For biconcave tibial designs**, the loading point shall be at the intersection with the tray of a line drawn normal to the tray which intersects the deepest part of the recess in the articular surface.
- b) **For other tibial components**, the femoral component, the tibial articulating surface component and the tibial tray shall be assembled at 0° flexion and the position of the centre of pressure determined. The centre of pressure shall be on the line perpendicular to the tray which passes through the loading point.

NOTE The position of the centre of pressure may be determined using pressure-sensitive film, removable dye, a 3-D CAD system or component drawings.

6.5 Measure the dimensions d_{ap} and d_{ml} (3.4, 3.5 and Figure 1).

6.6 Place the spacer (5.3) between the test specimen and the load applicator (Figure 1 or 2).

The spacer should be replaced if, during testing, its thickness is reduced to 3 mm or if it fragments.

NOTE The spacer may be fixed to the tray using epoxy resin cement.

6.7 With the spherical indenter in place, start the testing machine and adjust it so that it applies the maximum load F_{max} , using a minimum load to maximum load ratio of 10, at a frequency not greater than 10 Hz. The value of F_{max} shall be stated by the party submitting the specimen for test. Visually inspect the tray under normal or corrected vision every 5×10^5 cycles (see 6.8) without removing the tray from the testing machine.

6.8 Continue the test until one of the following occurs:

- a) the spacer thickness is reduced to 3 mm or it fragments;

In this case note the occurrence and fit a new spacer before continuing the test;

- b) the tray fractures;

ISO 14879-1:2000(E)

- c) cracks are observed when the tray is inspected under normal or corrected vision;
- d) 5×10^6 cycles test duration is achieved;
- e) the test machine fails to maintain the specified load range [5.1 b)].

6.9 At the end of the test:

- a) record the total number of cycles of loading applied when the test was terminated;
- b) report the reason for termination of the test;
- c) examine the test specimens using the methods requested by the party that submitted the specimen for testing.

7 Test report

The test report shall include the following information:

- a) a reference to this part of ISO 14879;
- b) the identity of the test specimens, as stated by the party submitting the specimen for test, including tibial tray thickness, size, d and w as defined in ISO 7207-1, and materials of construction;
- c) details of the test conditions, including spacer diameter and thickness (including any deviations in diameter or shape), d_{ml} , d_{ap} , fixation method, frequency, and maximum load;
- d) whether one or more replacement spacers was used;
- e) a statement of results including number of cycles applied and location of fracture (if fractured), description of test specimens at the end of the test, and the results of examination requested by the party submitting the specimen for test.

8 Disposal of test specimens

Test prostheses shall not be used for clinical purposes after testing. Care should be exercised in the use of the specimens for further mechanical tests, because the loading regime may have altered the mechanical properties.

Dimensions in millimetres

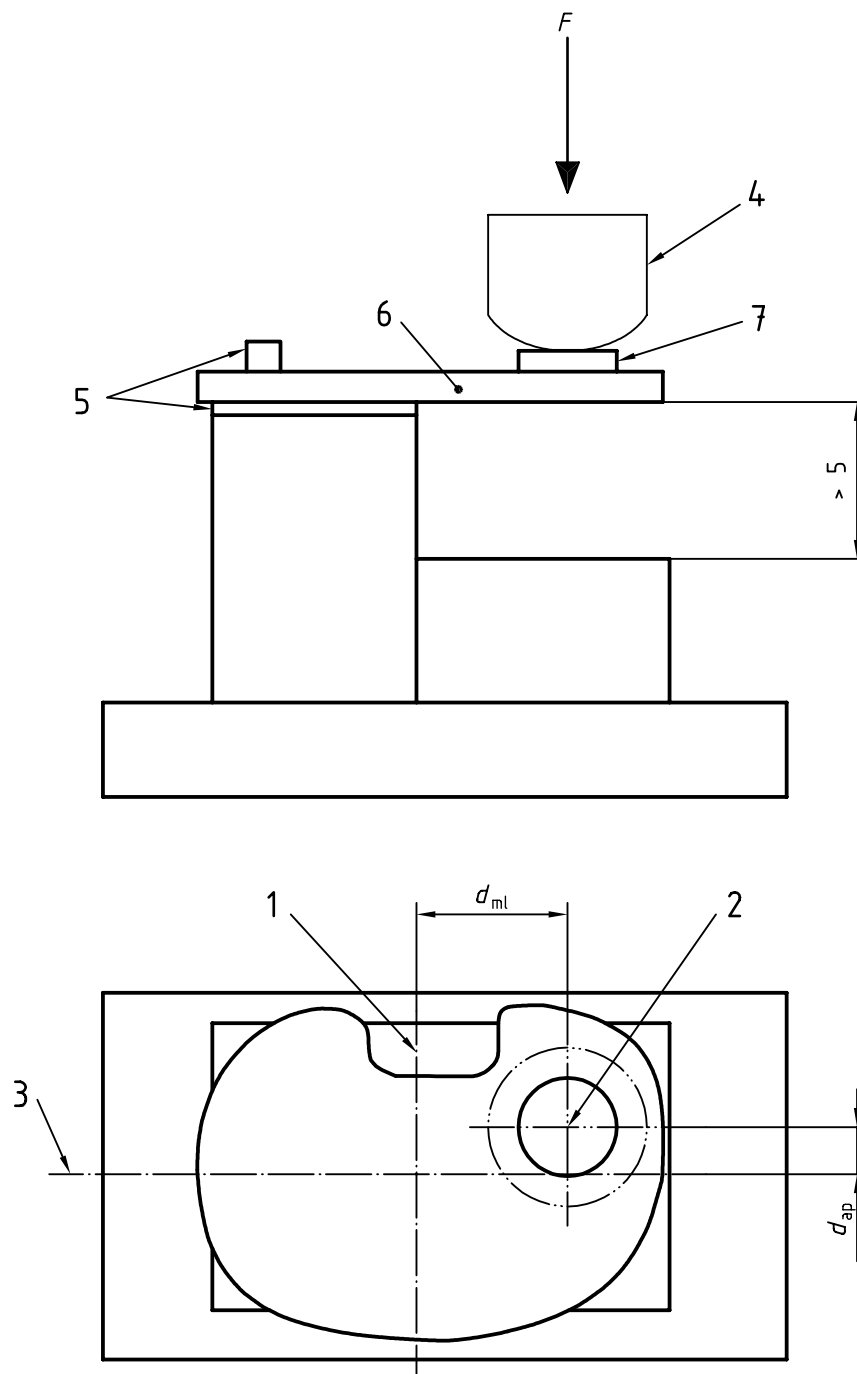

Key

- | | |
|------------------------------|--|
| 1 Anteroposterior centreline | 5 Fixation (away from the centreline and/or on the inferior surface) |
| 2 Point of load application | 6 Tibial tray |
| 3 Mediolateral centreline | 7 Spacer |
| 4 Load applicator | |

Figure 1 — Schematic diagram of test set-up for tibial trays without central stem (anterior view)

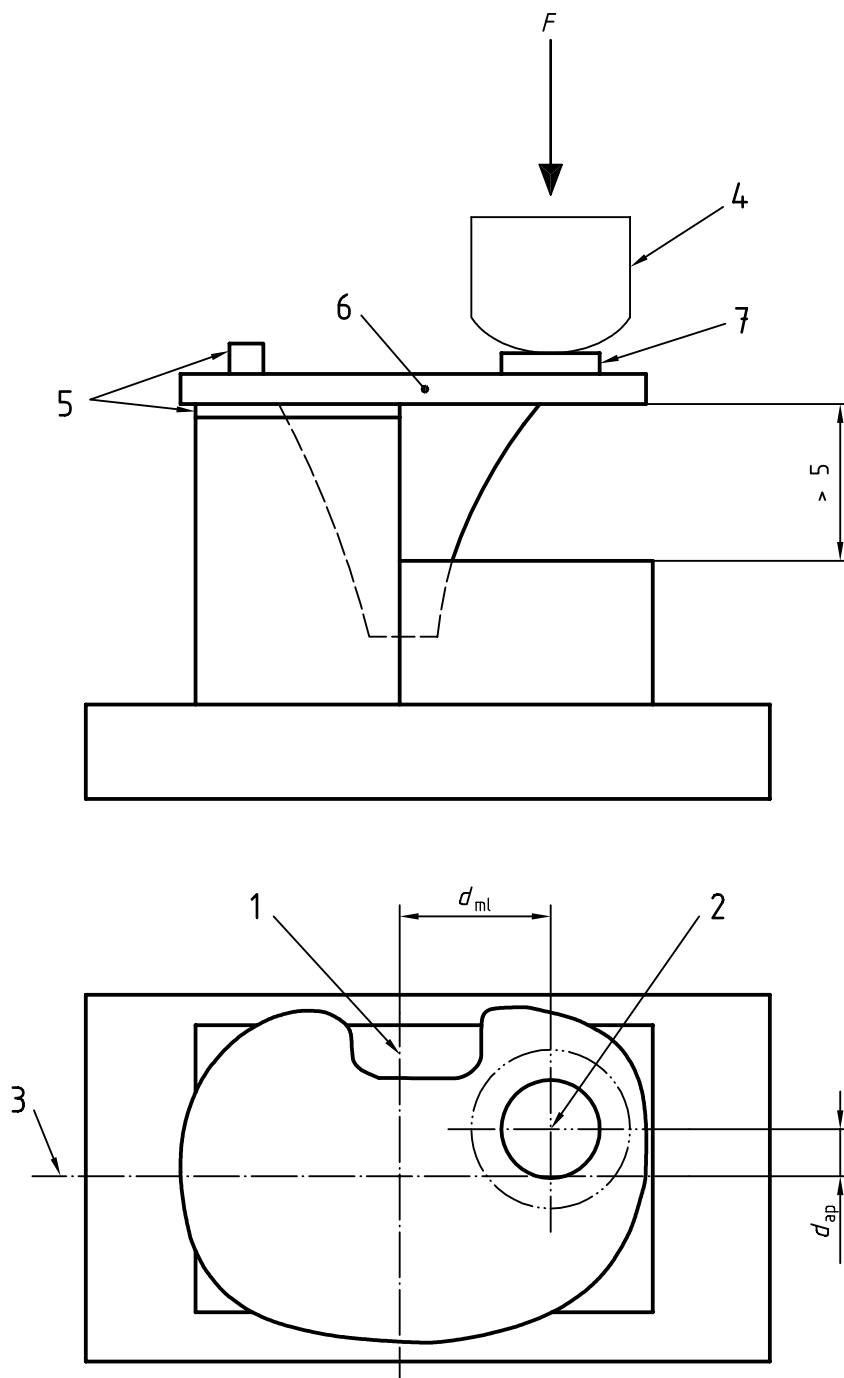

Key

- | | | | |
|---|----------------------------|---|--|
| 1 | Anteroposterior centreline | 5 | Fixation (away from the centreline and/or on the inferior surface) |
| 2 | Point of load application | 6 | Tibial tray |
| 3 | Mediolateral centreline | 7 | Spacer |
| 4 | Load applicator | | |

Figure 2 — Schematic diagram of test set-up for tibial trays with central stem (anterior view)

Bibliography

- [1] ISO 5833, *Implants for surgery — Acrylic resin cements*.
- [2] ISO 5834-2, *Implants for surgery — Ultra-high molecular weight polyethylene — Part 2: Moulded forms*.

ICS 11.040.40

Price based on 7 pages

© ISO 2000 – All rights reserved