

INTERNATIONAL STANDARD

ISO 14849

First edition
1999-08-01

Plastics — Phenol-formaldehyde mouldings — Determination of free ammonia and ammonium compounds — Indophenol method

*Plastiques — Pièces moulées à base de phénoplastes — Dosage de
l'ammoniac libre et des composés ammoniacaux — Méthode à l'indophénol*



Reference number
ISO 14849:1999(E)

Contents

1 Scope	1
2 Normative references	1
3 Terms and definitions	1
4 Principle	2
5 Reagents	2
6 Apparatus	3
7 Preparation of test sample	4
8 Procedure	4
9 Expression of results	7
10 Precision	7
11 Test report	8

© ISO 1999

All rights reserved. Unless otherwise specified, no part of this publication may be reproduced or utilized in any form or by any means, electronic or mechanical, including photocopying and microfilm, without permission in writing from the publisher.

International Organization for Standardization
Case postale 56 • CH-1211 Genève 20 • Switzerland
Internet iso@iso.ch

Printed in Switzerland

Foreword

ISO (the International Organization for Standardization) is a worldwide federation of national standards bodies (ISO member bodies). The work of preparing International Standards is normally carried out through ISO technical committees. Each member body interested in a subject for which a technical committee has been established has the right to be represented on that committee. International organizations, governmental and non-governmental, in liaison with ISO, also take part in the work. ISO collaborates closely with the International Electrotechnical Commission (IEC) on all matters of electrotechnical standardization.

International Standards are drafted in accordance with the rules given in the ISO/IEC Directives, Part 3.

Draft International Standards adopted by the technical committees are circulated to the member bodies for voting. Publication as an International Standard requires approval by at least 75 % of the member bodies casting a vote.

International Standard ISO 14849 was prepared by Technical Committee ISO/TC 61, *Plastics*, Subcommittee SC 12, *Thermosetting materials*.

Plastics — Phenol-formaldehyde mouldings — Determination of free ammonia and ammonium compounds — Indophenol method

1 Scope

This International Standard specifies a colorimetric comparison method for the determination of the amount of ammonia and ammonium compounds in phenol-formaldehyde mouldings.

NOTE This International Standard does not provide an absolute measure of the amount of ammonia present.

The amount of ammonia in a moulded article is of importance when corrosion of metal inserts or contamination of foodstuffs in contact with the article has to be considered.

2 Normative references

The following normative documents contain provisions which, through reference in this text, constitute provisions of this International Standard. For dated references, subsequent amendments to, or revisions of, any of these publications do not apply. However, parties to agreements based on this International Standard are encouraged to investigate the possibility of applying the most recent editions of the normative documents indicated below. For undated references, the latest edition of the normative document referred to applies. Members of ISO and IEC maintain registers of currently valid International Standards.

ISO 565:1990, *Test sieves — Metal wire cloth, perforated metal plate and electroformed sheet — Nominal sizes of openings.*

ISO 648:1977, *Laboratory glassware — One-mark pipettes.*

ISO 835-2:1981, *Laboratory glassware — Graduated pipettes — Part 2: Pipettes for which no waiting time is specified.*

ISO 1042:1988, *Laboratory glassware — One-mark volumetric flasks.*

ISO 3696:1987, *Water for analytical laboratory use — Specification and test methods.*

ISO 4788:1980, *Laboratory glassware — Graduated measuring cylinders.*

ISO 4793:1980, *Laboratory sintered (fritted) filters — Porosity grading, classification and designation.*

ISO 5725-2:1994, *Accuracy (trueness and precision) of measurement methods and results — Part 2: Basic method for the determination of repeatability and reproducibility of a standard measurement method.*

3 Terms and definitions

For the purposes of this International Standard, the following terms and definitions apply.

3.1

free ammonia

ammonia that is present in the form of NH_3 in phenol-formaldehyde mouldings

3.2

ammonium compound

an ammonium salt, present in a phenol-formaldehyde moulding, that has been produced by the reaction of ammonia with acid

NOTE In this method, ammonium compounds are determined as NH_3 .

4 Principle

The ammonia in a test portion of ground mouldings is extracted by heating with water. The extract is then distilled in alkaline conditions. The ammonia present in the distillate is determined by measuring the spectrophotometric absorbance of the indophenol blue generated by the reaction with phenol in the presence of hypochlorite ions. The reactions are as follows:

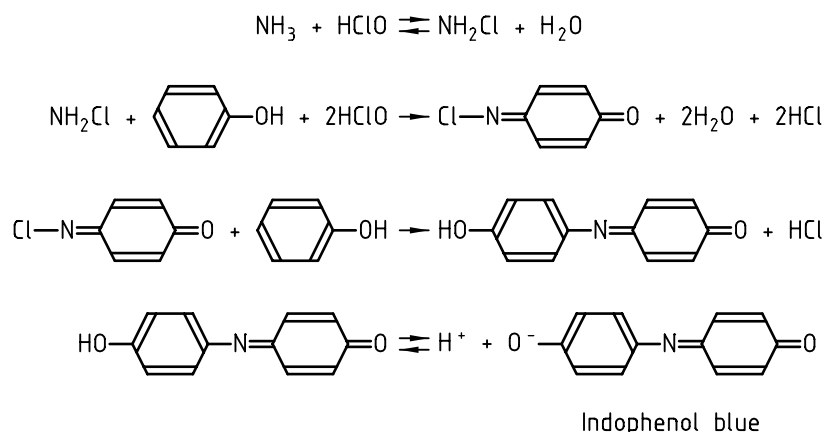

5 Reagents

During the analysis, use only ammonia-free reagents of recognized analytical grade, and only ammonia-free distilled water of grade 3 as defined in ISO 3696.

5.1 Potassium permanganate.

5.2 Sodium hydroxide, 2 % solution.

5.3 EDTA solution.

Dissolve 5 g of ethylenediaminetetraacetic acid disodium dihydrate in 100 ml of water.

5.4 Sodium phenolate solution.

Dissolve 20 g of sodium hydroxide in 100 ml of water. Then dissolve 25 g of phenol in 55 ml of this NaOH solution. Allow to cool to room temperature and add 6 ml of acetone. Dilute the resulting solution to 200 ml with water.

Since the solution of sodium phenolate tends to absorb carbon dioxide from the atmosphere, prepare it immediately before use.

5.5 Sodium hypochlorite solution, available-chlorine content 0,01 g/ml.

Determine the concentration of available chlorine in a solution of sodium hypochlorite with an available-chlorine content between 0,05 g/ml and 0,12 g/ml and dilute it with water so that the chlorine content is adjusted to approximately 0,01 g/ml.

Since sodium hypochlorite is prone to decomposition, prepare the solution immediately before use.

Determine the exact concentration of the sodium hypochlorite solution as follows:

Introduce 10 ml of the solution into a 200 ml volumetric flask and make up to 200 ml with water.

Transfer 10 ml of this solution to a conical flask. Dilute with 90 ml of water, making the total volume 100 ml. Add 1 g to 2 g of potassium iodide and 6 ml of acetic acid (1+1). Seal the flask and thoroughly mix the contents by shaking.

Place the flask containing the mixture in a dark place for about 5 min and then titrate the contents with 0,05 mol/l sodium thiosulfate solution (5.7). When the yellow solution becomes light-coloured, add about 2 ml of starch solution (5.8) and continue the titration until the blue colour of starch iodide disappears.

Separately, carry out a blank test on 10 ml of water and correct the titration volume accordingly.

Calculate the available-chlorine content N , in grams per millilitre, of the sodium hypochlorite solution from the equation

$$N = V_2 \times f \times \frac{200}{10} \times \frac{1}{V_1} \times 0,001\,773$$

where

V_1 is the volume, in millilitres, of sodium hypochlorite solution transferred to the conical flask (i.e. 10 ml);

V_2 is the volume, in millilitres, of 0,05 mol/l sodium thiosulfate solution required for the titration;

f is a correction factor for the case when the concentration of the sodium thiosulfate solution is not exactly 0,05 mol/l;

0,001 773 is the mass, in grams, of chlorine corresponding to 1 ml of 0,05 mol/l sodium thiosulfate solution.

5.6 Standard ammonia solution, $c(\text{NH}_3) = 0,01$ mg/ml.

Put 3,141 g \pm 0,001 g of ammonium chloride, which has been dried to constant mass at 105 °C (but in any case for a minimum of 2 h) into a 1 000 ml volumetric flask and make up to the mark with water. Pipette 10 ml of this solution into a second 1 000 ml volumetric flask and again make up to the mark with water.

5.7 Sodium thiosulfate solution, $c(\text{Na}_2\text{S}_2\text{O}_3) = 0,05$ mol/l.

Dissolve 7,906 g of sodium thiosulfate in water in a 1 000 ml volumetric flask, and make up to the mark with water.

5.8 Starch solution.

Take 1 g of starch, and dissolve in 100 ml of water.

6 Apparatus

Ordinary laboratory apparatus, plus the following:

6.1 Means for reducing the mouldings to powder, for example drill, file, ball mill, mortar and pestle.

6.2 Sieve, with nominal openings of 250 μm as specified in ISO 565.

6.3 Analytical balances, one accurate to 0,01 g, the other accurate to 0,001 g.

6.4 Flask, capacity 100 ml, with ground-glass stopper.

6.5 Graduated measuring cylinders, capacity 100 ml and 50 ml, with ground-glass stoppers, both conforming to ISO 4788.

6.6 Glass filter, porosity P160 as specified in ISO 4793, or **high-speed filter paper**.

6.7 One-mark pipette, class A as specified in ISO 648, capacity 10 ml, and graduated pipette, class A as specified in ISO 835-2, capacity 10 ml.

6.8 One-mark volumetric flasks, class A as specified in ISO 1042, capacities 50 ml, 200 ml and 1000 ml.

6.9 Conical flask, capacity 300 ml, with ground-glass stopper.

6.10 Distillation apparatus, as shown in Figure 1 or Figure 2.

6.11 Photometer or spectrophotometer.

7 Preparation of test sample

Reduce a representative sample of the moulding to powder by filing, milling, grinding or drilling, taking care that no undue heating of the material occurs. Sieve the powder, using the sieve described in subclause 6.2. The test sample shall consist of the portion that passes through the sieve. Keep the test sample in a tightly stoppered flask, and start the extraction procedure described in clause 8 within 1 h of preparing it.

8 Procedure

8.1 Extraction

Weigh out $5 \text{ g} \pm 0,1 \text{ g}$ of the sieved material (see clause 7) to the nearest 0,01 g. Place this test portion in a 100 ml flask (6.4). Using a 100 ml measuring cylinder (see 6.5), add 50 ml of water, heated to not less than 90 °C, and immediately stopper the flask with its ground-glass stopper. Shake the flask so that the powder is thoroughly wetted.

Allow to cool, and leave at room temperature for 1 h, with occasional shaking. Then filter the contents of the flask, without suction, through a glass filter or filter paper (6.6).

8.2 Distillation

Using a pipette (6.7), transfer 10 ml of the filtered extract to a 250 ml distillation flask (see Figure 1 or 2). Add 1 g of potassium permanganate (5.1) and 10 ml of 2 % sodium hydroxide solution (5.2). Gently distill the mixture using the apparatus shown in Figure 1 or 2. Collect the first 15 ml of distillate in a 50 ml measuring cylinder (see 6.5). Make up to 25 ml with water.

NOTE If the purple colour of potassium permanganate disappears, add further potassium permanganate so as to keep the purple colour.

8.3 Measurement

To the 25 ml of solution obtained in 8.2, add 1 ml of EDTA solution (5.3) and 10 ml of sodium phenolate solution (5.4), and mix by shaking the stoppered measuring cylinder. Then add 5 ml of sodium hypochlorite solution (5.5) and make up to 50 ml with water. Stopper and mix by shaking. Allow to stand for 30 min, keeping the temperature of the solution at $23 \text{ °C} \pm 2 \text{ °C}$.

Transfer part of this solution to a 10 mm absorption cell, and measure the absorbance at 630 nm wavelength. Also carry out a blank test at 630 nm wavelength using water, and correct the measured absorbance of the test solution.

From the calibration curve prepared as described in subclause 8.4, read off the mass of ammonia, in milligrams, in the test solution.

If the mass of ammonia in the test solution lies outside the range covered by the calibration curve, dilute the filtrate to bring it within the range of the calibration curve.

The depth of colour of the solution is temperature-dependent, and it is therefore essential that the temperature of the solution is kept at $23 \text{ °C} \pm 2 \text{ °C}$. The solutions used in the preparation of the calibration curve shall also be kept at this temperature.

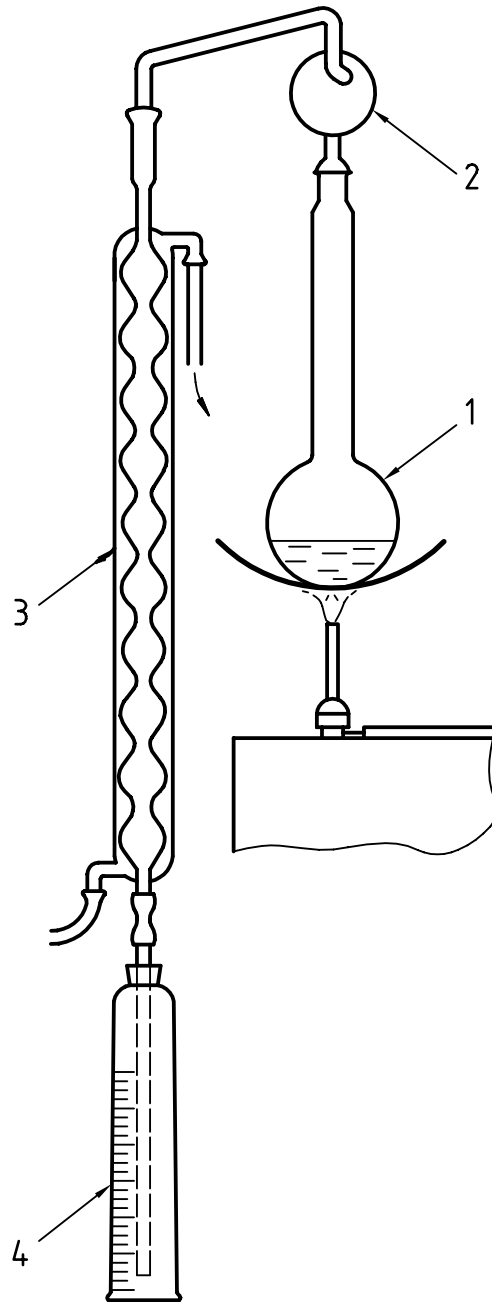
**Key**

- 1 Distillation flask (250 ml)
- 2 Splash head (Kjeldahl type)
- 3 Condenser
- 4 Measuring cylinder

Figure 1 — Example of distillation apparatus (simple distillation)

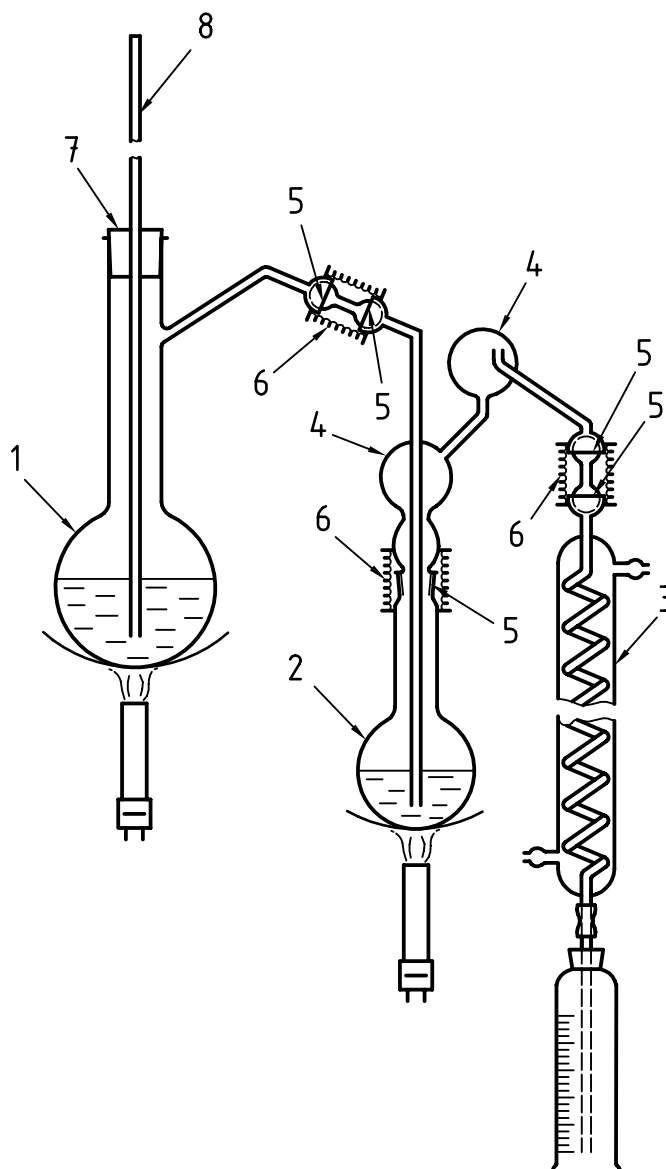

Key

- 1 Steam-generation flask
- 2 Distillation flask (250 ml)
- 3 Condenser
- 4 Splash heads
- 5 Ground-glass joints
- 6 Retention springs
- 7 Rubber bung
- 8 Glass tube

Figure 2 — Example of steam-distillation apparatus

8.4 Preparation of the calibration curve

Using between 0,5 ml and 10 ml of standard ammonia solution (5.6) and a series of 50 ml volumetric flasks (see 6.8), prepare at least three solutions with different ammonia concentrations. Then, using the procedure described in subclause 8.3, measure the absorbances and plot a graph showing the relationship between absorbance and the mass of ammonia in the solution. Ensure that the absorbance of the test solution lies within the range covered by the calibration solutions.

NOTE Interfering materials:

Iron(II) and copper(II) — Concentrations of less than 0,15 mg/l do not interfere with the measurement. For concentrations of up to 1 mg/l, the interference is removed by the addition of the EDTA.

Fatty-acid amines — No interference.

Aromatic amines, e.g. aniline — Cause interference when coloured material is generated by oxidation by hypochlorite.

p-Aminophenol — Generates indophenol blue by reaction with phenol in alkaline solution and therefore interferes.

Hydroquinone — No interference.

Hydroxylamine — Interference may be removed by oxidation with a quantitative addition of a 30 % aqueous solution of hydrogen peroxide.

9 Expression of results

Calculate the content of free ammonia and ammonium compounds *A*, expressed as a percentage by mass of ammonia (NH₃), in the sample using the equation

$$A = \frac{m}{1000} \times D \times \frac{50}{10} \times \frac{1}{m_0} \times 100$$

$$= \frac{m}{2m_0} \times D$$

where

*m*₀ is the mass, in grams, of the test portion (see 8.1);

m is the mass of ammonia, in milligrams, in the test solution (see 8.3);

D is the dilution factor in the case where the filtrate was diluted before distillation, given by

$$D = \frac{V_4}{V_3}$$

*V*₃ being the volume, in millilitres, before dilution, of the portion of filtered extract taken (i.e. 10 ml),

*V*₄ being the volume, in millilitres, after dilution, of the 10 ml portion of filtered extract.

10 Precision

The precision was determined from interlaboratory trials carried out in Japan in accordance with ISO 5725-2. The results are summarized in Table 1.

Table 1 — Interlaboratory trial data

Values in percent

	Type of resin ^a	q	s_r	s_R	m	n	p
Free ammonia ^b	Novolac	0,2/0,5	0,0130	0,0155	0,292	24	8
	Resol	0,001/0,005	0,00070	0,00072	0,0022	12	4
<p>where</p> <p>q is the measurement interval (max. and min. free-ammonia concentrations used);</p> <p>s_r is the repeatability standard deviation;</p> <p>s_R is the reproducibility standard deviation;</p> <p>m is the mean result;</p> <p>n is the number of tests;</p> <p>p is the number of laboratories which participated in the trials.</p> <p>^a Type of phenol-formaldehyde resin used to produce the mouldings used for the trials.</p> <p>^b Including ammonium compounds.</p>							

11 Test report

The test report shall include the following particulars:

- a) a reference to this International Standard;
- b) all details necessary for complete identification of the sample;
- c) the method used to reduce the mouldings to powder;
- d) the content of free ammonia and ammonium compounds;
- e) the date of the test.

ICS 83.080.10

Price based on 8 pages
