

---

---

**Intelligent transport systems — Traffic  
and travel information messages via  
traffic message coding —**

**Part 1:  
Coding protocol for Radio Data System —  
Traffic Message Channel (RDS-TMC)  
using ALERT-C**

*Systemes intelligents de transport — Informations sur le trafic et le  
tourisme via le codage de messages sur le trafic —*

*Partie 1: Protocole de codage pour le système de radiodiffusion de  
données (RDS) — Canal de messages d'informations sur le trafic  
(RDS-TMC) avec ALERT-C*



.....



**COPYRIGHT PROTECTED DOCUMENT**

© ISO 2013

All rights reserved. Unless otherwise specified, no part of this publication may be reproduced or utilized otherwise in any form or by any means, electronic or mechanical, including photocopying, or posting on the internet or an intranet, without prior written permission. Permission can be requested from either ISO at the address below or ISO's member body in the country of the requester.

ISO copyright office  
Case postale 56 • CH-1211 Geneva 20  
Tel. + 41 22 749 01 11  
Fax + 41 22 749 09 47  
E-mail [copyright@iso.org](mailto:copyright@iso.org)  
Web [www.iso.org](http://www.iso.org)

Published in Switzerland

# Contents

Page

Foreword .....	v
Introduction.....	vii
<b>1 Scope .....</b>	<b>1</b>
1.1 General scope.....	1
1.2 Content .....	1
1.3 Message management .....	2
1.4 Transmission .....	2
1.5 Event list.....	2
<b>2 Normative references.....</b>	<b>2</b>
<b>3 Terms, definitions and abbreviated terms .....</b>	<b>2</b>
3.1 Terms and definitions .....	2
3.2 Abbreviated terms .....	5
<b>4 Application .....</b>	<b>7</b>
4.1 General .....	7
4.2 Definition of the TMC "travel service" .....	7
4.3 TMC virtual terminal .....	8
4.4 Event-oriented end-user information messages.....	8
4.5 Strategic and tactical information .....	8
4.6 Geographic relevance.....	9
4.7 Transmitted message priority.....	9
4.8 Event List .....	10
4.9 Future extensions.....	10
<b>5 Presentation .....</b>	<b>10</b>
5.1 General .....	10
5.2 TMC virtual language .....	10
5.3 Message content .....	11
5.3.1 General .....	11
5.3.2 Event Description (11 bits) .....	11
5.3.3 Primary Location (16 bits) .....	11
5.3.4 Direction and Extent (4 bits).....	12
5.3.5 Duration (3 bits).....	13
5.3.6 Diversion Advice (1 bit).....	14
5.4 Implicit information .....	15
5.4.1 Road class and road number .....	15
5.4.2 Road segment.....	15
5.4.3 Area, region and country .....	15
5.4.4 Pre-assigned diversion advice.....	15
5.4.5 Urgency within the terminal .....	15
5.4.6 Directionality.....	15
5.4.7 Duration type .....	16
5.4.8 Nature .....	16
5.4.9 Update class .....	16
5.4.10 Quantifier type .....	16
5.5 Optional message content.....	16
5.5.1 General .....	16
5.5.2 Combination of additional information .....	17
5.5.3 Control codes (label 1).....	18
5.5.4 Length of route affected (label 2).....	18
5.5.5 Speed limit (label 3).....	18

5.5.6	Additional quantifiers (labels 4 and 5).....	19
5.5.7	Supplementary information (label 6) .....	19
5.5.8	Start and stop times (labels 7 and 8) .....	19
5.5.9	Multi-event messages (label 9).....	19
5.5.10	Detailed diversion instructions (label 10) .....	20
5.5.11	Destinations (label 11).....	20
5.5.12	Precise location reference (label 12) .....	20
5.5.13	Cross linkage to source of problem (label 13).....	21
5.5.14	Separator (label 14) .....	22
5.5.15	Other information as defined by sub-labels (label 15).....	22
5.5.16	Reference to telephone services (label 15, sub-label 1-2).....	22
6	Message management .....	25
6.1	General.....	25
6.2	System messages.....	26
6.2.1	General.....	26
6.2.2	Location table.....	26
6.2.3	Terminal requirements .....	26
6.2.4	Change of database numbers .....	27
6.3	Message repetition .....	27
6.4	Message updating.....	28
6.5	Message deletion .....	28
6.5.1	General.....	28
6.5.2	Message persistence.....	28
6.5.3	Detailed stop-time.....	29
6.5.4	Silent cancellation message.....	29
6.5.5	Null message.....	29
6.6	Message presentation .....	30
6.7	Out of area referencing .....	30
6.7.1	Structure of the INTER-ROAD concept.....	30
6.7.2	INTER-ROAD messages.....	31
6.7.3	Updating and cancellation of INTER-ROAD messages .....	31
7	Transmission.....	32
7.1	General.....	32
7.2	Format of type 8A groups .....	32
7.3	Immediate repetition.....	32
7.4	Single-group user messages.....	33
7.5	System messages.....	34
7.5.1	General.....	34
7.5.2	System information .....	34
7.5.3	Tuning information .....	38
7.6	Multi-group messages.....	40
7.6.1	First group .....	40
7.6.2	Subsequent groups .....	41
7.7	Summary of X-bit usage in RDS-TMC type 8A groups .....	43

## Foreword

ISO (the International Organization for Standardization) is a worldwide federation of national standards bodies (ISO member bodies). The work of preparing International Standards is normally carried out through ISO technical committees. Each member body interested in a subject for which a technical committee has been established has the right to be represented on that committee. International organizations, governmental and non-governmental, in liaison with ISO, also take part in the work. ISO collaborates closely with the International Electrotechnical Commission (IEC) on all matters of electrotechnical standardization.

The procedures used to develop this document and those intended for its further maintenance are described in the ISO/IEC Directives, Part 1. In particular the different approval criteria needed for the different types of ISO documents should be noted. This document was drafted in accordance with the editorial rules of the ISO/IEC Directives, Part 2. [www.iso.org/directives](http://www.iso.org/directives)

Attention is drawn to the possibility that some of the elements of this document may be the subject of patent rights. ISO shall not be held responsible for identifying any or all such patent rights. Details of any patent rights identified during the development of the document will be in the Introduction and/or on the ISO list of patent declarations received. [www.iso.org/patents](http://www.iso.org/patents)

Any trade name used in this document is information given for the convenience of users and does not constitute an endorsement.

For an explanation on the meaning of ISO specific terms and expressions related to conformity assessment, as well as information about ISO's adherence to the WTO principles in the Technical Barriers to Trade (TBT) see the following URL: [Foreword - Supplementary information](#)

The committee responsible for this document is ISO/TC 204, *Intelligent transport systems*.

This second edition cancels and replaces the first edition (ISO 14819-1:2003), which has been technically revised.

ISO 14819 consists of the following parts, under the general title *Intelligent transport systems — Traffic and travel information messages via traffic message coding*:

- *Part 1: Coding protocol for Radio Data System — Traffic Message Channel (RDS-TMC) using ALERT-C*
- *Part 2: Event and information codes for Radio Data System — Traffic Message Channel (RDS-TMC) using ALERT-C*
- *Part 3: Location referencing for Radio Data System — Traffic Message Channel (RDS-TMC) using ALERT-C*
- *Part 6: Encryption and conditional access for the Radio Data System — Traffic Message Channel ALERT C coding*

Compared to previous releases, this version includes the following additions:

- Precise location referencing
- Tendencies of Traffic Queue Lengths (TTQL)
- Coding of parking POIs
- Coding of interrupted roads

## ISO 14819-1:2013(E)

- Coding of other isolated POIs (except parking POIs)
- Coding of parallel roads
- Version identification of TMC location tables
- Location Table Exchange Format
- North American Safety Events in TMC
- Explicit Location Table Country Code transmission in TMC
- Guidelines for Service Providers and Terminal Manufacturers for Implementation of explicit Location Table Country Code transmission
- Coding of link roads
- GB-English - List of Quantifiers
- Additional Event Codes identified by Germany
- Additional TMC Events from Danish proposal
- Additional TMC Supplementary Information: Unconfirmed Report
- RDS-TMC delivery of IVR Telephone Number
- Coding of link roads

## Introduction

Traffic and traveller information (TTI) may be disseminated through a number of services and means of communication to the end user, including static displays (e.g. Variable Message Signs), broadcast audio to car radios, broadcast data services to in-vehicle equipment (e.g. installed navigation system) and to nomadic device terminals (e.g. portable navigation device).

For all such services, the data to be disseminated and the message structure involved in the various interfaces require clear definition and standard formats, in order to allow competitive products to operate with any received data.

This part of ISO 14819 describes the data specification for TTI messages, together with their network layer and their service layer, which shall be conveyed by the RDS-TMC feature, specified in IEC 62106 (Second edition - 2009).

The TTI information chain, from event to end-user is quite complex and the TISA (the Traveller Information Services Association) value chain shown in Figure 1 helps to understand the key components:



**Figure 1 — The Traveller Information Services Association TTI value chain**

A number of entities (e.g. companies, businesses) take part in one or more activities to complete the activities shown in the value chain. Two, in particular are described, for improved understanding:

**Service Provider:** An organisation that constructs a data service, by gathering data, processing data and supplying the data service. A Service Provider then negotiates for the use of the necessary data bandwidth with a Broadcaster and/or Transmission Operator. A Service Provider is responsible for the "quality" of the content to his customers and must provide suitable customer support.

**Broadcaster:** A traditionally incorporated organisation responsible for a continuous strand of audio programmes and their quality. A broadcaster may also be responsible for overall co-ordination of "broadcast transmissions" (often a Broadcaster is the licensee of a national regulator). A Broadcaster may also be a Service Provider.

TTI services for travellers, using spoken radio reports and in-vision reports occupy broadcast air-time and whilst valuable to some, they are considered less useful by others. Furthermore, only some are useful for travellers on the move. Due to the widespread adoption of the Radio Data System, in VHF/FM broadcasting on Band II there is the possibility of transmitting coded TTI messages digitally and "silently" using the RDS-TMC feature, which avoids the interruption of planned programmes. This TTI delivery method has a number of advantages: TTI messages can be decoded into the language of the end user, regardless of location, more messages can be made available and planned broadcast programme interruption is avoided, so make delivery of TTI messages more timely and topical.

The ALERT-C protocol defined in this part of ISO 14819 supports a data broadcasting service for travellers, providing information about many kinds of traffic and travel events. Messages include traffic incident information relating to national and regional routes and some urban roads and other information required by a traveller, such as roadworks and weather information.

## ISO 14819-1:2013(E)

This part of ISO 14819 is based on the ALERT-C traffic message coding protocol, which was a product of DRIVE Project V1029, "RDS Advice and Problem Location for European Road Traffic". The RDS-ALERT project aimed to define standards for RDS-TMC, working in conjunction with the European Broadcasting Union (EBU) and the European Conference of Ministers of Transport (ECMT).

The international standard has been implemented in many countries worldwide and, as a result of very extensive implementation experience, it has matured with many changes from the earliest version of the ALERT-C proposal of 1990. At that time CEN TC 278 Sub-working group (SWG) 4.1 developed the coding protocol, herein and the event list described in ISO 14819-2; meanwhile CEN TC 278 SWG 7.3 developed the location referencing method which is described in ISO 14819-3. Subsequently the TMC Forum was responsible for collecting specific additions and improvements intended for inclusion in this part of ISO 14819. Latterly, the Traveller Information Services Association (TISA) took over all responsibility (including TMC Forum legacy) for maintenance of this part of ISO 14819, which now includes an up to date set of industry supported enhancements to RDS-TMC.

The RDS system is fully described in IEC 62106 (Second edition, 2009) and it contains the 'hooks' to RDS-TMC, detailed in this part of ISO 14819. It employs a group structured data protocol. It uses type 3A groups defined to carry Open Data Application (ODA) identification and service and network layer information. This enables signalling of the TMC feature in other data groups. It uses type 8A groups defined to carry RDS-TMC messages and location information, together with TMC service tuning information.

Broadly, two types of RDS-TMC services are required: one that is, in effect, free of charge at the point of use by an end user and thus uses un-encrypted data, and one that is paid-for using encrypted data. The conditional access capability was developed by the TMC Forum and is described in ISO 14819-6.



# Intelligent transport systems — Traffic and travel information messages via traffic message coding —

## Part 1: Coding protocol for Radio Data System — Traffic Message Channel (RDS-TMC) using ALERT-C

### 1 Scope

#### 1.1 General scope

The ALERT-C protocol is designed to provide mostly event-oriented road end-user information messages. Many "hooks" have been left for future development and a few status-orientated road end-user information messages were included.

#### 1.2 Content

The presentation section of the ALERT-C protocol specifies messages that may be presented to the user in accordance with the general requirements set out above. It defines the message structure and content, and its presentation to the end-user.

RDS-TMC messages are language-independent, and can be presented in the language of the user's choice. The ALERT-C protocol utilises a standardised Event List (ISO 14819-2) of event messages with their code values, which also includes general traffic problems and weather situations.

ALERT-C defines two categories of information within messages: basic and optional items. In principle, basic information is present in all messages. Optional information can be added to messages where necessary.

Standard RDS-TMC user messages provide the following five basic items of explicit, broadcast information:

1. **Event description**, giving details of road event situations, general traffic problems and weather situations (e.g. congestion caused by accident) and where appropriate its severity (e.g. resulting queue length).
2. **Location**, indicating the area, road segment or point location where the source of the problem is situated.
3. **Direction and Extent**, identifying the adjacent segments or specific point locations also affected by the incident, and where appropriate the direction of traffic affected.
4. **Duration**, giving an indication of how long the problem is expected to last.
5. **Diversion advice**, showing whether or not end-users are recommended to find and follow an alternative route.

Optional information can be added to any message using one or more additional RDS data groups. This optional addition can give greater detail or can deal with unusual situations. Any number of additional fields can in principle be added to each basic message, subject only to a maximum message length of five RDS data groups.

### 1.3 Message management

The message management component deals with the message management functions of RDS-TMC. The ALERT-C protocol distinguishes between user messages and system messages. User messages are those potentially made known to the end-user, as defined in the presentation section. System messages are of use only to the RDS-TMC terminal, for message management purposes.

### 1.4 Transmission

The transmission component conveys the messages over-air. The ALERT-C protocol, which RDS-TMC uses, retains the fundamental approach of earlier work, which aims to code most messages entirely within a single RDS group.

RDS-TMC information comprises both 'system information' and 'user messages'. System information relates to the particular TMC service, and details the parameters that the terminal needs to be able to find identify and decode the TMC information. System information is transmitted in type 3A groups and in type 8A groups.

User messages contain the details of the traffic events; these may use one or more type 8A groups. Most messages may be transmitted using a single type 8A group, however messages with more detail (e.g. diversion advice) may use up to a total of five, type 8A groups.

### 1.5 Event list

The ALERT-C Event List contains all event descriptions. It is described in ISO 14819-2.

## 2 Normative references

The following documents, in whole or in part, are normatively referenced in this document and are indispensable for its application. For dated references, only the edition cited applies. For undated references, the latest edition of the referenced document (including any amendments) applies.

ISO 4217:2008, *Codes for the representation of currencies and funds*

ISO 8601:2004, *Data elements and interchange formats — Information interchange — Representation of dates and times*

ISO 14819-2, *Intelligent transport systems — Traffic and travel information messages via traffic message coding — Part 2: Event and information codes for Radio Data System — Traffic Message Channel (RDS-TMC) using ALERT-C*

ISO 14819-3, *Intelligent transport systems — Traffic and travel information messages via traffic message coding — Part 3: Location referencing for Radio Data System — Traffic message Channel (RDS-TMC) using ALERT-C*

IEC 62106:2009, *Specification of the radio data system (RDS) for VHF/FM sound broadcasting in the frequency range from 87.5 to 108.0 MHz*

## 3 Terms, definitions and abbreviated terms

### 3.1 Terms and definitions

For the purposes of this document, the following terms and definitions apply.

**3.1.1****Application Identifier**

signals the specific group type used by the Open Data Application

Note 1 to entry: Defined in the RDS specification IEC 62106.

**3.1.2****Continuity Index Field**

helps distinguish between different multi-group messages

Note 1 to entry: All groups within any particular multi-group message contain the same value of this continuity index.

**3.1.3****Country Code**

assigns a code to each country

Note 1 to entry: Country codes are not unique to one country and can be repeated in non-neighbouring countries.

Note 2 to entry: In RDS, The Country Code is transmitted in the first 4-bits of the PI code to signal the origin of the audio programme, which may be different to the country where the transmitter is located.

Note 3 to entry: Defined in the RDS specification IEC 62106.

**3.1.4****Direction and Extent**

identifies the adjacent segments or specific point locations also affected by the incident, and where appropriate the direction of traffic affected

**3.1.5****Diversion Advice**

shows whether or not end-users are recommended to find and follow an alternative route

**3.1.6****Duration**

gives an indication of how long the problem is expected to last

**3.1.7****End-user**

covers the meaning for all possible terminal clients

Note 1 to entry: This could be a vehicle driver, a user of a portable or fixed TMC receiver or an intelligent client that processes the information such as in a navigation system.

**3.1.8****Event Description**

gives details of the traffic problem (e.g. congestion caused by accident) and where appropriate its severity (e.g. resulting queue length) or weather situation

**3.1.9****Event List**

agreed table of event descriptions and parameters, assigning an event code value and giving the details of traffic problem (e.g. congestion caused by accident) and where appropriate its severity (e.g. resulting queue length) or the weather situation

Note 1 to entry: Defined in ISO 4217:2008.

**3.1.10****Foreign Location Table**

location table which is different from the default location table used by the transmitter

### 3.1.11

#### **INTER-ROAD**

way of referencing locations from other location tables via special multi-group messages

Note 1 to entry: These messages can be used to inform end-users about problems in other areas, in particular in neighbouring countries.

### 3.1.12

#### **Extended Country Code**

assigns a unique code to each country

Note 1 to entry: The combination of ECC and CC altogether assigns a unique code for each country.

Note 2 to entry: Defined in the RDS specification IEC 62106.

### 3.1.13

#### **Location**

indicates the area, road segment or point location where the source of the problem is situated

### 3.1.14

#### **Location Table**

agreed table which contains for each service information the area, road segment or point location where the source of the problem is situated

Note 1 to entry: Each location table is identified by three elements: a Number – Location Table Number, a Location Table Country Code, and a Location Table Extended Country Code. The combination of these three elements identifies a Location Table uniquely. Each service has a Location Table defined by Location Table Number, a Location Table Country Code and Location Table Extended Country Code.

### 3.1.15

#### **Location Table Country Code**

assigns a code to each location table, based on the country of origin of the locations referenced in this table

### 3.1.16

#### **Location Table Extended Country Code**

assigns a code to each location table, based on the country of origin of the locations referenced in this table

Note 1 to entry: Together the LTECC, LTCC and LTN identify a location database uniquely.

### 3.1.17

#### **Open Data Application**

provides the means for adding applications to an RDS transmission

Note 1 to entry: Defined in the RDS specification IEC 62106.

### 3.1.18

#### **Programme Identifier**

assigns a unique value to each audio programme source

Note 1 to entry: Defined in the RDS specification IEC 62106.

### 3.1.19

#### **Programme Identifier Country Code**

first four bits of the Programme Identifier are identical with Country Code if the RDS specification IEC 62106 is implemented

Note 1 to entry: The CC is signalled in the RDS PI Code for purposes of identifying the country of origin of the audio programme.

Note 2 to entry: Usually the Programme Identifier Country Code and the Location Table Country Code on an RDS-TMC transmission have the same value, but not always nor necessarily.

**3.1.20****Silent Cancellation Message**

used to delete messages from the end-user terminal

**3.1.21****Service-ID**

used to uniquely identify a particular TMC service from a service provider

**3.1.22****System Information**

enables an RDS-TMC terminal to decode and evaluate essential data, which describes the transmission being received

Note 1 to entry: System Information indicates an RDS-TMC service and comprises some service characteristics needed to select the RDS-TMC service.

**3.1.23****Terminal**

provides the user interfaces with the TMC service

Note 1 to entry: Their functionality may cover a range of terminal functions from simple terminals with a limited message repertoire and restricted location database to more sophisticated terminals offering full TMC message features and/or a wide range of strategic and tactical location databases.

**3.1.24****Tuning Information**

enables a RDS-TMC terminal to change from one transmitter to another at boundaries of a particular transmitter's coverage

Note 1 to entry: Each transmitter should direct the RDS-TMC terminal to specific frequencies or TMC services in adjacent areas.

**3.1.25****User Message**

describes the messages which are potentially made known to the end-user

Note 1 to entry: They contain event, location, direction and extent, duration etc. descriptions.

**3.1.26****TISA**

not-for-profit membership organisation established under Belgian law aiming at developing and maintaining worldwide traffic and traveller information standards such TMC and TPEG

**3.2 Abbreviated terms**

For the purposes of this document, the following abbreviated terms apply.

**3.2.1****AF**

Alternative Frequency - an RDS feature

**3.2.2****AFI**

Alternative Frequency Information - an RDS-TMC feature

**3.2.3****AID**

Application Identifier - an RDS feature

## **ISO 14819-1:2013(E)**

### **3.2.4**

#### **ALERT-C**

Advice and Problem Location for European Road Traffic, Version C

### **3.2.5**

#### **CC**

Country Code - an RDS feature

### **3.2.6**

#### **CT**

Clock Time - an RDS feature

### **3.2.7**

#### **EBU**

European Broadcasting Union

### **3.2.8**

#### **ECC**

Extended Country Code -an RDS feature

### **3.2.9**

#### **ECMT**

European Conference of Ministers of Transport

### **3.2.10**

#### **IVR**

Interactive Voice Response – an information telephone call, typically automated

### **3.2.11**

#### **LTCC**

Location Table Country Code

### **3.2.12**

#### **LTECC**

Location Table Extended Country Code

### **3.2.13**

#### **LTN**

Location Table Number

### **3.2.14**

#### **MGS**

Message Geographical Scope

### **3.2.15**

#### **ODA**

Open Data Application –an RDS feature

### **3.2.16**

#### **ON**

Other Network - an RDS feature

### **3.2.17**

#### **PI**

Programme Identifier - an RDS feature

### **3.2.18**

#### **PICC**

Programme Identifier Country Code

**3.2.19****RDS**

Radio Data System

**3.2.20****rfu**

Reserved for future use

**3.2.21****SID**

Service-ID

**3.2.22****TISA**

Traveller Information Services Association

**3.2.23****TMC**

Traffic Message Channel

**3.2.24****TN**

Tuned Network

**3.2.25****UTC**

Universal Co-ordinated Time

**4 Application****4.1 General**

Spoken broadcast traffic messages already provide a valuable information service to motorists in countries throughout Europe. Digital broadcasting techniques have now become available due to the widespread adoption of the Radio Data System (RDS). RDS enables traffic messages to be carried digitally and silently by a Traffic Message Channel (TMC), without necessarily interrupting the audio programme.

The ALERT-C protocol defined in this specification supports a digital, silent broadcast service for motorists, providing information about many kinds of traffic events. This includes roadworks, weather and traffic incident information relating to major national and international routes, regional routes and local roads.

Some basic information about public transport is included within the scope of the current protocol for the special case of ferries and short rail links designed to carry road vehicles, such as Alpine tunnels or the Channel Tunnel.

**4.2 Definition of the TMC "travel service"**

ALERT-C defines the Traffic Message Channel (TMC) as a travel service digitally and silently broadcast using RDS, which can provide an end-user with:

- event-oriented end-user information on the nature, severity and probable evolution of both urban and interurban traffic problems;
- reduced frustration and uncertainty due to this provision of timely and helpful information;
- assistance with journey planning, including rerouting and rescheduling of trips to avoid current or projected strategic traffic situations;

- details of local traffic incidents which may be avoidable through the use of minor diversions;
- status-orientated information on traffic conditions which can help to support intelligent on-vehicle route guidance equipment; and
- additional data on roadside amenities and tourism information which can in future complement and update on-vehicle mobile databases.

#### 4.3 TMC virtual terminal

Information broadcast digitally and silently can only be interpreted by suitable RDS-TMC terminals. These RDS-TMC terminals provide the user interfaces with the TMC service. Their functionality may vary substantially according to technical developments and market requirements, which cannot be wholly predicted in advance. Instead, a **virtual terminal** model is defined which covers a range of terminal functions, including:

- simple terminals with a limited message repertoire and restricted location database;
- more sophisticated terminals offering full TMC message features and/or a wide range of strategic and tactical location databases;
- terminals which monitor only a single, selected TMC service, and others which employ more sophisticated search strategies of several or many channels;
- terminals which are active before the start of a journey, and others which must acquire their TMC data after the journey begins; and
- terminals which provide output via speech synthesis and/or visual displays, and others which interface to more sophisticated on-vehicle route guidance equipment.

#### 4.4 Event-oriented end-user information messages

The ALERT-C protocol defines only **event-oriented end-user information** messages.

**End-user information** messages are those designed primarily to service an in-vehicle terminal, offering information directly to end-users via speech synthesis and/or displays. Terminals can also be used in home and office terminals or public access terminals, to assist in pre-trip journey planning.

**Event-oriented** messages describe deviations from the normal traffic equilibrium state, and include problems such as congestion, roadworks, adverse weather conditions, accidents, ferry delays or cancellations, etc.

#### 4.5 Strategic and tactical information

ALERT-C follows EBU Guidelines on Broadcasts for Motorists, revised June 1990, in distinguishing between strategic information, of value for trip planning and route selection in the medium term, and tactical information likely to be of relevance for immediate local diversions around current traffic problems.

In more detail, broadcast traffic information comprises:

- a) immediate "tactical" information, for transmission as soon as possible, with frequent repeats;
- b) medium-term "strategic" information, for transmission at intervals, according to available channel capacity;
- c) long-term "background" information, for transmission from time to time;
- d) forecasts such as weather and expected road conditions, traffic density, coming events, etc.; and
- e) tourist and other messages, including public transport information, which may be relevant for motorists.



The ALERT-C protocol follows these guidelines, aiming to allow as many as possible of the existing spoken messages to be carried in similar forms using the digital TMC medium.

#### 4.6 Geographic relevance

ALERT-C utilises location coding strategies prepared in guidelines developed within the DRIVE Project. These guidelines adopt hierarchical principles of structuring the location database in accordance with EBU Broadcast for Motorists group functional recommendations for strategic and tactical messages. This is dealt with in ISO 14819-3.

This protocol does not address the internal management of traffic messages by broadcasters in respect of geographic relevance. In the following it is assumed, that broadcasters will arrange to transmit messages with a priority that is appropriate to its geographic relevance. This means, that the frequency with which a message is inserted into the message cycle is not only dependent on the event but is also a function of the location in relation to the broadcasting area.

Extremely urgent messages (X-messages) have to be included by all relevant services that cover the respective area in which the X-message is located.

#### 4.7 Transmitted message priority

Message priorities used by broadcasters adopting RDS-TMC should follow the current approach set out in the EBU Guidelines on Broadcasts for Motorists, revised June 1990. In the context of RDS-TMC, this can be interpreted as the following range of transmitted message priorities:

- a) **Extremely urgent information** with highest priority, for immediate broadcast, interrupting existing RDS-TMC message cycles and being repeated very frequently;
- b) **Tactical information**, for non-delayed broadcast, with frequent repeats;
- c) **Strategic information**, broadcast at intervals according to RDS-TMC channel capacity; and
- d) **Background information**, broadcast less frequently, when channel capacity permits.

The ALERT-C protocol **does not** address the internal management of traffic messages by broadcasters in respect of broadcast message priority. The protocol assumes that broadcasters will arrange to transmit messages at the appropriate level of priority using existing procedures such as those defined by the EBU Guidelines on Broadcasts for Motorists, revised June 1990.

RDS is a single direction broadcast system – and hence a service provider has no means of knowing if any RDS data has been successfully and correctly received by any RDS audio receiver or TMC terminal.

A number of factors, including the topology of the broadcasting area, the insertion level of the RDS data signal and the location of a particular terminal affect its ability to receive RDS information. To optimise the possibility of a terminal receiving RDS data, all RDS groups are transmitted more than once.

For information that is static (or static for long periods), RDS groups are repeated periodically, the period between successive repeated groups may be several minutes.

For data relating to dynamically changing situations (e.g. traffic conditions), the appropriate RDS-TMC groups are repeated in quick succession. Typically a type 8A RDS-TMC message group is transmitted, followed by between three and eleven non-TMC groups, then an exact repeat of the type 8A RDS-TMC message, another gap of between three and eleven non RDS-TMC message groups, and finally another repeat of the RDS-TMC message group. The transmission of groups according to this so-called 'immediate' repetition pattern was shown in field trials to be optimal for a terminal to acquire RDS data.

In this ALERT-C protocol, a terminal is required to receive at least two identical RDS-TMC groups, through either immediate or periodic repetitions, before it can accept the data as being valid (see 7.3 and 7.6).

The protocol **does** address the separate question of message urgency within the decoder (see 5.4.5). This aspect of the protocol can be used by terminal manufacturers to determine how a terminal will respond when it receives an RDS-TMC message. Depending on the duration type of the event (see Explanatory notes in the Event List), a message is defined as dynamic or longer lasting dynamic messages may be inserted more often in the periodic repetition cycle and must be update more often in relation to their duration. Longer lasting messages may be transmitted less frequently.

#### 4.8 Event List

For the purposes of event-oriented end-user-information messages, ALERT-C protocol utilises a standard International list of traffic related event descriptions and weather information.

#### 4.9 Future extensions

Provision is made for future extensions to the protocol:

- using the undefined elements of the ALERT-Plus switch bit (x4);
- using the location numbers reserved in the upper part of the location tables; and
- by means of code combinations left unused in the present coding (e.g. continuity index 000 and 111).

### 5 Presentation

#### 5.1 General

The presentation section of the ALERT-C protocol specifies messages, which can be presented to the end-user in accordance with the general requirements set out in the application component. It defines the message structure and content, and its presentation to the end-user.

#### 5.2 TMC virtual language

Traffic Message Channel (TMC) information is conveyed using a "virtual language" in which the codes broadcast over-air comprise addresses of information stored in databases in the terminals. These databases contain lists of road event situations, including general traffic problems and weather situations, advice, durations and other information; plus lists of locations, including intersections, road numbers and place names.

Several processes are involved in the presentation section:

- a) before transmission, information concerning an event is mapped into the TMC virtual language by selection from nested menus of event descriptions and other items, or by a fully-automated traffic monitoring and reporting system;
- b) the resulting coded messages are transmitted via RDS, with frequent repetitions;
- c) in the terminal, the TMC codes are checked to see if they contain new information or are updates of already received messages. New codes are stored in memory and are subject to message management; and
- d) at appropriate times the codes are translated back into messages using look-up tables for presentation to the end-user.

In this virtual language concept, the Event List used at the source and those used in an individual terminal are not necessarily identical. For example, the messages may be input in one language and reproduced in another. Translated event descriptions are maintained by the Traveller Information Services Association ([www.tisa.org](http://www.tisa.org)).

Much of the information conveyed by the codes is implicit and is derived from secondary look-up tables stored in the terminals. These tables are not addressed by explicit fields in the broadcast information, but are derived from the context of the message itself combined with information from the message management and other RDS codes defined in IEC 62106:2009 ed2.0.

### 5.3 Message content

#### 5.3.1 General

The ALERT-C protocol defines two categories of information within messages: basic and optional items. In principle, basic information items are present in all messages. Optional information can be added to messages where necessary.

Distinction is also made between explicit and implicit information. **Explicit information** is broadcast directly using defined codes. **Implicit information** is derived from the secondary look-up tables stored within the terminal, which only occasionally will be explicitly overruled using optional, additionally transmitted codes.

RDS-TMC user messages provide the following five basic items of explicit, broadcast information:

- a) **Event Description**, giving details of the weather situation or traffic problem (e.g. congestion caused by accident) and where appropriate its severity (e.g. resulting queue length);
- b) **Location**, indicating the area, road segment or point location where the source of the problem is situated;
- c) **Direction and Extent**, identifying the adjacent segments or point locations also affected by the event, and where appropriate the direction of traffic affected;
- d) **Duration**, giving an indication of how long the problem is expected to last; and
- e) **Diversions Advice**, showing whether or not end-users are recommended to find and follow an alternative route.

#### 5.3.2 Event Description (11 bits)

The event description utilised by this part of ISO 14819 is given in the event list which is detailed in part 2 of ISO 14819. Many event descriptions are single phrase descriptions. In addition to these, the Event List contains event descriptions in which two or more phrases from the Datex1 Data Dictionary (:2000, version 3.1a) have been combined, so that they can be used (similarly as a single phrase description) in a single-group message. The event descriptions in the Event List are grouped into update classes. These are used to regulate updating and cancellation of messages (see 6.4). A number of attributes are attached to each event description in the Event List. These are described in 5.4, Implicit Information, and in the Explanatory notes in the Event List.

#### 5.3.3 Primary Location (16 bits)

Where the source of a problem (e.g. an accident; a bottleneck) occurs **at** a defined TMC location, its primary location can be broadcast using the relevant location number.

Where the source of a directional problem (e.g. queue) occurs **between** two TMC point locations, its primary location can be broadcast using the location number of the nearest downstream point, measured in the direction of traffic affected.

Where such an event is defined to be bi-directional (see 5.4.6) its primary location can be broadcast using **either** of the two nearest defined TMC locations which straddle the event.

Where a terminal receives a TMC message referring to a location not included in its database, it shall produce no message output to the end-user.

The highest 2048 location numbers shall not be used for geographical objects. They are reserved for special purposes. Some of these numbers are used in 'INTER-ROAD' messages to indicate the number of a foreign location table (i.e. a location table different from the default table used by the transmitter, see 6.7).

Other location numbers with a special function are:

- number 65533: indicates that the message is intended for all listeners, regardless their position or destination and regardless any geographic selection filter they may have activated in their terminal. This can be used for general, not necessarily urgent, information about the TMC-service, or for countrywide bad weather warnings. Instead of the location name, a terminal may present a phrase such as '(message) for all users';
- number 65534: 'silent' location code [again ignoring any geographic filter in a terminal], to indicate that no location name or alternative phrase shall be presented at all. This can also be used for general information messages, and may be useful for some other purposes; and
- number 65535 (the highest 16-bit number): for location-independent updating or cancelling of messages.

Messages with location 65533 and 65534 are subject to the normal updating rules given in 6.4, i.e. they can only overwrite, or be overwritten by, messages with the same special location number, provided that also the other rules in 6.4 are satisfied.

### 5.3.4 Direction and Extent (4 bits)

#### 5.3.4.1 General

This information within messages identifies the direction (1 bit) and a location extent (3 bits) of up to seven "steps" through adjacent, defined TMC locations also affected by the event. The last step in this chain identifies a secondary TMC location, which, together with the primary location, straddles the event.

#### 5.3.4.2 Direction (1 bit)

The direction bit (0 = positive, 1 = negative) shall indicate the direction of queue growth for all event types defined as directional; i.e. it is opposite to the direction of traffic flow affected. The convention specifying positive and negative directions along each road shall be fixed at the time of coding the definitive location database.

When an event is defined bi-directional, thus affecting both directions, the direction bit is only used for locating the secondary location (Section 5.3.4.3).

#### 5.3.4.3 Extent (3 bit)

The extent identifies a chain of up to seven steps through adjacent defined TMC locations, also affected by the event. The last step in this chain identifies the secondary location, which together with the primary location straddles the event.

When the event affects only one TMC location, the extent is zero.

Where occasionally the event affects more than seven adjacent point locations, they should normally be described at the segment level as being located within one or more segments. If exceptionally this is not adequate, further locations affected can be defined using optional additional information (see 5.5.2), adding up to 24 steps to the chain of steps.

### 5.3.5 Duration (3 bits)

The duration code in messages provides for eight levels of expected continuation of the problem. The interpretation of the duration code depends on the nature and the duration type of the event as defined in the Event List (see also 5.4).

For single-group messages, the duration is a basic item, coded in a pre-allocated 3-bit field (see also 7.4). For multi-group messages, the duration is an optional item (see 5.5). Also, more detailed stop-times and start-times of problems can be defined within multi-group messages (see 7.6).

Field trials suggested that estimating a valid duration is often difficult. Also, the information can be distracting, especially if it is of limited accuracy. Therefore, use of Code 0 in the first three following tables is recommended wherever there is uncertainty about duration. Also, where end-users can reasonably make their own assumptions about the likely duration, Code 0 should be used. Finally, terminal manufacturers may choose to make the presentation of duration a user-selectable option. The non-spoken duration is coded as 0 and is not allowed in multi-group messages.

In the case of dynamic events with an 'information' nature (as specified in the Event List), the duration code indicates periods relating to an end-user's current journey. These durations are defined as: "The situation is expected to continue for...".

Code	Meaning	Decrement?
0	(no explicit duration to be given)	do not decrement
1	for at least the next 15 minutes	do not decrement
2	for at least the next 30 minutes	decrement after 15 minutes
3	for at least the next 1 hour	decrement after 30 minutes
4	for at least the next 2 hours	decrement after 1 hour
5	for at least the next 3 hours	decrement after 1 hour
6	for at least the next 4 hours	decrement after 1 hour
7	for the rest of the day	do not decrement

Dynamic events with a 'forecast' nature shall be accompanied by durations that indicate how soon the situation is expected. These durations are defined as:

Code	Meaning	Decrement?
0	(no explicit start-time to be given)	do not decrement
1	within the next 15 minutes	do not decrement
2	within the next 30 minutes	decrement after 15 minutes
3	within the next 1 hour	decrement after 30 minutes
4	within the next 2 hours	decrement after 1 hour
5	within the next 3 hours	decrement after 1 hour
6	within the next 4 hours	decrement after 1 hour
7	later today	do not decrement

Some events are expected to last for longer periods, as identified in the Event List. In the case of information events, these durations are defined as "The situation is expected to continue...".

Code	Meaning	Decrement?
0	(no explicit duration to be given)	do not decrement
1	for the next few hours	do not decrement
2	for the rest of the day	do not decrement

Code	Meaning	Decrement?
3	until tomorrow evening	decrement at midnight
4	for the rest of the week	decrement Friday midnight
5	until the end of next week	decrement Sunday midnight
6	until the end of the month	do not decrement
7	for a long period	do not decrement

Longer period events described in the Event List as 'forecast' events shall be accompanied by time horizons, which indicate when the situation is expected. These durations are defined as:

Code	Meaning	Decrement?
0	(no explicit time horizon given)	do not decrement
1	within the next few hours	do not decrement
2	later today	do not decrement
3	Tomorrow	decrement at midnight
4	the day after tomorrow	decrement at midnight
5	this weekend	do not decrement
6	later this week	do not decrement
7	next week	do not decrement

As indicated above, some duration codes must be decremented in the terminal at the end of each time period specified. For this purpose RDS type 4A group shall be transmitted and used as time base.

Each new week starts at midnight on Sunday evening (i.e. 00:00, Monday morning, see ISO 8601).

Thus, "the end of next week" shall be decremented within the terminal to "the rest of the week" at midnight on Sunday evening. "Until tomorrow evening" shall be decremented to "for the rest of the day" at midnight on the day of message receipt. "For at least the next four hours" shall be decremented to "at least the next three hours" one hour after it was last received. This will ensure that a terminal will present reasonable durations or time horizons even if it could not update the respective message.

The infrastructure is expected to decrement the duration also at the times indicated above (duration countdown).

For international message exchange and for transmission Co-ordinated Universal Time (UTC) shall be used. For presentation to the end-user local time (based on the time zone at the terminal side) shall be used.

Some messages in the Event List are allocated a default of "no explicit duration to be given". With these messages, any permitted value defined above can be used to set persistence (see 6.5.2).

The duration type specified in the event list can be overridden using control codes defined in 5.5.3.

### 5.3.6 Diversion Advice (1 bit)

The diversion bit, included in single-group messages only indicates whether end-users are recommended to find and follow an alternative route around the traffic problem described elsewhere in the message. The messages are defined as:

Code	Meaning
0	(no diversion recommended)
1	end-users are recommended to avoid the area if possible.

For multi-group messages where the diversion bit is not present, a control code is defined which has the same effect as the diversion bit (see 5.5.3). If pre-defined diversion routes exist, they can be given to the end-users.

With bi-directional events, pre-defined diversion advice is given only for one direction (from secondary to primary location), as it is not always possible to decide whether a diversion advice for the opposite direction is also wanted.

## 5.4 Implicit information

### 5.4.1 Road class and road number

See ISO 14819-3.

### 5.4.2 Road segment

See ISO 14819-3.

### 5.4.3 Area, region and country

See ISO 14819-3.

### 5.4.4 Pre-assigned diversion advice

In some countries, motorway diversions are pre-assigned. These diversion routes can be stored in the terminal memory along with the location and extent codes that address them. Thus if the diversion bit is set, this route can be recommended to the end-user (see 5.3.6).

### 5.4.5 Urgency within the terminal

Each of the event descriptions listed in the Event list carries one of three levels of default urgency stored within the terminal:

- X        Extremely urgent, (present to all end-users immediately).
- U        Urgent, (present to end-users having selected this location, immediately).
- (blank)    Normal urgency, (make available to end-users on request).

Manufacturers are expected to use these levels to implement features that draw end-users' attention to specific messages, according to their urgency.

The urgency of a multi-event message (see 5.5.9) is equal to that of the most urgent of the constituent events.

It is also possible to transmit any message with an urgency other than its default, by using an optional additional control code (see 5.5.3). The service providers are responsible to decide which priority a given message should have, based not only on the urgency but also on location in relation to the service area (see 4.6).

### 5.4.6 Directionality

Each event description listed in the Event List has one of two default indications of direction, which may indicate either:

- a) only one direction of traffic affected (indicated by the direction bit, see 5.3.4.2);
- b) both directions affected by the event.

A multi-event message that contains any unidirectional event, is by default unidirectional.

The unidirectional default code may be overruled by explicitly sending two separate messages, one for each direction of traffic flow. The ALERT-C protocol also provides for an optional, additional control code that inverts the default directionality of a message, as defined in 5.5.3. If a bi-directional message is applied to a point location along a road, or to a road or road segment (as defined in ISO 14819-3), it should be made clear in presenting the message to the end-user (by additional words or other means) that both directions of traffic are affected.

#### 5.4.7 Duration type

Each event code carries one of two duration types, defined in the event list. These indicate whether an event is normally expected to be dynamic, or longer lasting. Interpretation of the duration field depends on this parameter. An optional, additional control code can invert the normal duration status (see 5.5.3).

#### 5.4.8 Nature

Each event description is defined as information or forecast description in the Event List. Some event descriptions are defined as silent; i.e. they produce no spoken message. Their functions are described in the message management section.

#### 5.4.9 Update class

Each event code belongs to an update class in the Event List. This is used for message management, e.g. updating or deletion of messages.

#### 5.4.10 Quantifier type

Some event descriptions have an additional quantifier, of which the type is specified in the event list (see also 5.5.6).

### 5.5 Optional message content

#### 5.5.1 General

Optional information can be added to any message using one or more additional RDS groups. This optional addition can give greater detail or can deal with unusual situations. Any number of additional fields can in principle be added to each basic message, subject only to a maximum message length of five RDS groups (see 7.2).

A 4-bit label specifies each of sixteen types of additional information. Each label is followed by a data field of defined length. The label types and data field lengths are as follows:

Label	Data field	Type of Information
0	3 bits	Duration (code 000 is not allowed for optional content)
1	3 bits	Control code
2	5 bits	Length of route affected
3	5 bits	Speed limit advice.
4	5 bits	Quantifier
5	8 bits	Quantifier
6	8 bits	Supplementary information code
7	8 bits	Explicit start time (or time when problem was reported) for end-user information only
8	8 bits	Explicit stop time for end-user information and message management
9	11 bits	Additional event
10	16 bits	Detailed diversion instructions



Label	Data field	Type of Information
11	16 bits	Destination
12	16 bits	Precise location reference
13	16 bits	Cross linkage to source of problem, on another route
14	0 bits	Separator
15	6 bits	Other information as defined by sub-labels

### 5.5.2 Combination of additional information

In composing multi-group messages, a service provider has to satisfy the following rules:

- a) label 0, label 7, label 8, label 13 and each control code under label 1 (see 5.5.3) may be used only once per message (this implies the maximum problem extent  $7+8+16 = 31$  steps);
- b) label 14 may be used as separator between different parts of a message (information blocks"). Some types of additional data fields are allowed only once per information block (see below), to avoid ambiguity. Separators can be helpful for terminals to make messages easier to understand for end-users, by grouping the message content syntactically. For instance, a terminal could use label 14 to make a short pause in spoken output;
- c) following labels may be used at most once per information block (i.e. before the first separator, between two subsequent separators, after the last separator, or per message if the message contains no label 14):
  - label 2 (length of route affected);
  - label 3 (speed limit advice).
- d) the remaining labels (4, 5, 6, 9, 10, 11, 15) can be used more than once (see further sections for the use of these labels); and
- e) if a detailed diversion route is valid for one or more specific destinations only, the destination(s), i.e. a label 11 plus data field for each, must immediately precede the (first) diversion instruction (i.e. label 10 plus data field). If destination(s) are used in connection with other (e.g. supplementary) information, they must not directly be followed by label 10 (in such cases a separator before label 10 is recommended). If the diversion bit is set (with label 1, code 5), then an additional detailed diversion route can only be given for (a) specific destination(s), and the use of a separator (label 14) between label 1 and the subsequent labels 11 and 10 is recommended (see also 5.5.10 and 5.5.11).
- f) label 15 shall only be used as the last label.

### 5.5.3 Control codes (label 1)

Each control code can be applied only once to any message. Their meanings are as follows; a detailed description is defined in the message management section.

ALERT-C defines eight terminal control codes that can be used in a 3-bits field following label 1 in any multi-group message. Their meanings are:

Code	Meaning
0	Default urgency increased by one level
1	Default urgency reduced by one level
2	Default directionality of message changed
3	Default dynamic or longer-lasting provision interchanged
4	Default spoken or unspoken duration interchanged
5	Equivalent of diversion bit set to "1"
6	Increase the number of steps in the problem extent by eight
7	Increase the number of steps in the problem extent by sixteen

Regarding Codes 0 and 1, urgency changes shall also wrap around so that increasing the most urgent level creates the least urgent of the three, and vice-versa.

Regarding Code 2, messages are either **directional** or **bi-directional**. Use of Code 2 reverses this status.

Code 3 changes the timescale of events, from **dynamic** to **longer term** or vice-versa.

Code 4 changes the default spoken duration from **spoken** to **unspoken** or vice-versa.

Use of Code 5 shall be equivalent to setting the diversion bit to "1" in a single-group message (see also 5.3.6).

Codes 6 and 7 deal with problems which extend further than is provided in the message problem extent field. When Code 6 is appended to a message, the number of steps indicated in the message shall be increased by eight. Code 7 provides for a further eight steps, where necessary, increasing the number of steps by sixteen.

### 5.5.4 Length of route affected (label 2)

The length of route affected can be added (at most once per information block), for use with events that do not already contain this information. The meaning of the data codes is as follows:

0	Problem extends for more than 100 km
1-10	Length of problem from 1 to 10 km (1 km interval)
11-15	Length of problem from 12 to 20 km (2 km interval)
16-31	Length of problem from 25 to 100 km (5 km interval)

### 5.5.5 Speed limit (label 3)

One speed limit advice per information block can be added to any message. The meaning of the data codes is as follows:

1-26	Maximum speed from 5 to 130 km/h (5 km/h interval)
------	--

### 5.5.6 Additional quantifiers (labels 4 and 5)

Some event descriptions have an additional quantifier, of which the type is specified in the event list. Label 4 must precede a 5-bits quantifier field and label 5 an 8-bits quantifier field. Which one is to be used depends on the event; see the Event List.

### 5.5.7 Supplementary information (label 6)

One or more supplementary phrases can be added to any message, using the codes defined in ISO 4217:2008.

### 5.5.8 Start and stop times (labels 7 and 8)

One start-time and/or one stop-time may be added once to any Message. Time and date codes shall use Co-ordinated Universal Time (UTC) and Modified Julian Day (MJD) The presentation will not use this information directly, but conversion to local time and date will be made in the terminal's circuitry. For this purpose RDS type 4A groups shall be transmitted and used to determine the local time. The meanings of the start and stop time codes are as follows:

0-95	00:00 to 23:45 (15 minute interval)
96-200	Hour and day, starting at midnight following message receipt (1 hour interval)
201-231	First to thirty-first day of the month (1 day interval)
232-255	January-15 to December-31 (half month interval)

A data code in the range 0-95 indicates a time during the current day. For example, a start time received at 09:00 with a code of 42 means "problem expected from 10:30 this morning" whereas the same code received at 11:00 means "problem reported at 10:30 this morning".

A data code in the range 96-200 indicates a time within the next few days. For example, a stop time received at 09:00 on Friday with a code of 153 means "until 09:00 Monday". A start time of 153 means "from 9:00 Monday". These codes shall be updated by broadcasters at midnight each day (i.e. at 00:00 UTC), by decrementing the code by 24. If the result in a code is less than 96, the appropriate code in the range 0 - 95 is to be calculated. For example a stop time with code 153 first transmitted on Friday will be decremented to 129 on 00:00 Saturday, to 105 on 00:00 Sunday and to code 36 on 00:00 on Monday.

A data code in the range 201-231 indicates a date during the next 31 days. For example, a stop time received on August-20 with a code of 218 means "until September-18".

A data code in the range 232-255 indicates a date during the next 12 months. For example, a stop time received in September with a code of 236 means "until mid-March next year" while 239 means "until the end of April next year".

Start times are for end-user information only, and do not affect terminal message management. Stop times override the normal terminal message management strategy, defined in the message management section (see 6.4), as well as providing an explicit announcement to the end-user.

### 5.5.9 Multi-event messages (label 9)

With label 9, one or more additional event codes can be added to any message, forming a multi-event message with the event coded in the first message group. The primary location, direction and extent given in the first group (see 5.3) apply to the whole message.

A multi-event message must not contain a silent event (i.e. an event indicated by 'S' in the Event List).

If a multi-event message contains a duration code (following label 0), this code shall be interpreted, as described in 5.2.4, according to the nature and duration type (see Event List) of the last event preceding the label 0 in the sequence of additional information. (This last preceding event may be the first-group event).

Any quantifier (following label 4 or 5) added to a multi-event message shall be taken to apply to the last event (which may be the first-group event) preceding the quantifier in the sequence of additional information. If this last preceding event does not allow for a quantifier, or only for a quantifier with a different field length, or has already been matched to a quantifier, the given quantifier shall be ignored.

The urgency of a multi-event message is equal to that of the most urgent of the constituent events. If all constituent events are bi-directional, the multi-event message is bi-directional, otherwise it is unidirectional.

#### 5.5.10 Detailed diversion instructions (label 10)

Information about a diversion route can be given by adding one or more locations along that route to the message. Each location along the diversion must be identified by label 10 followed by a 16-bits location code, which refers to the same TMC location table as that used for the same primary location in the message.

Up to three different diversion routes may be specified, preferably separated by label 14, and subject to the maximum of five groups per message. The second (and, if present, the third) route may only be given for specific destination(s), which means that the label(s) 10 and location(s) specifying that route must be preceded by at least one label 11 plus location code (see also 5.5.2, rule e) and 5.5.11). The locations along one diversion route must be given directly after one another, i.e. with no labels other than 10 in between.

The first location along the detailed diversion should be interpreted as "Diversion recommended via (location)", and subsequent locations as "... and then via (location)". The sequence of points along the diversion shall be the same as the sequence of diversion fields in the message.

Where detailed diversions are recommended in both directions, separate messages shall be used for each direction.

#### 5.5.11 Destinations (label 11)

In special cases, a general diversion advice (code 5 under label 1), a detailed diversion (see above) or another instruction or advice (under label 3, 6 or 9) may be relevant only for traffic heading for one or more particular destination(s). Each of such a destination can be indicated using label 11 followed by a 16-bit location code (referring to the same database as the primary location). The destination(s) is/are then followed by the information to which they apply (which are all items until the next label 11 or 14 or the end of the message). See 5.5.2 for some additional rules.

A destination given at the end of an information block applies to preceding information, which may be or include the first group event, e.g. a trip/journey time (from the primary location to that destination).

A destination shall be interpreted as "for traffic heading towards (location)", but directly following one label 11 as "... and (location)".

#### 5.5.12 Precise location reference (label 12)

Any message can be sent with a precise location reference. The precise location reference gives the location of the start and end of the event with reference to an existing TMC primary location (see ISO 14819-3).

The data sent as label 12 shall specify the hazard distance (D1) and information on reliability, status and direction of change of the hazard point. Label 12 may only be used once per message.

If the traffic problem has non-zero length one of the following two options shall be used to indicate its length - proper choice of event code, or Optional Message Content label 2 (Length of route affected), which requires the use of an additional group.

When the TMC message contains more than 1 event, then, if used, the precise location reference shall be the maximum distance D1 of all actual locations of the individual events which are contained in the message. Thus the event with a hazard point closest to the secondary location shall be chosen for the precise location reference.

#### 5.5.12.1 Coding of the hazard distance (D1), reliability, status and direction

The available 16 bits are divided into 11 bits for the description of the distance between hazard location and the pre-defined primary location (with a resolution of 100 m/bit), 2 bits to indicate the accuracy of the reported precise location, and 3 bits to indicate the reliability of the precise information, the type of the problem, and the direction of change of the location. The use of the bits is as follows:

bits 0-10	distance of hazard point location from pre-defined primary location (i.e. distance D1) with 100 m resolution	
bits 12/11	hazard location accuracy:	0/0 = 100 m accuracy or better 0/1 = 500 m accuracy or better 1/0 = 1 km accuracy or better 1/1 = accuracy more imprecise than 1 km
bit 13	hazard location reliability	0 = reliable 1 = approximate (confirmation desired)
bits 15/14	hazard point dynamics	0/0 = static (e.g. road works, black ice, hazard point is stationary) 0/1 = dynamic, approaching (e.g. tail of traffic jam queue, hazard point moves towards the secondary location) 1/0 = dynamic, receding (e.g. tail of traffic jam queue, hazard point moves towards the primary location) 1/1 = dynamics and movement unknown (hazard point may be moving in unknown direction)

#### 5.5.12.2 Coding of the traffic problem length (L)

In case of a non-zero length traffic problem its length shall be indicated (at choice, depending on the situation) in one of two ways - proper choice of event code (e.g. code 102 to indicate stationary traffic for 1 km) or use of label 2, length of route affected, as defined in section 5.5.4.

#### 5.5.13 Cross linkage to source of problem (label 13)

Any message can be cross-linked to another location, which constitutes the source of the traffic problem reported. In this case, instead of the cause of the problem being located at or before the primary location of the main message, it is located near to the cross-linked location.

Use of this option can be illustrated by means of an example. If an accident on Route 1 causes a queue onto Route 2, it can be reported on Route 2 by means of a message "accident, queuing traffic" whose primary location is on Route 2 (at the intersection with Route 1), cross-linked to the actual accident location on Route 1. Any queue length or affected length quantifier for the Route 2 message should give only the affected length on Route 2. The situation on Route 1 can be described by separate messages, which shall not utilise the cross-linkage field.

On receipt of this information the terminal should announce the traffic problems on Route 2, caused by an accident near the specified Route 1 location.

In multi-event messages the source of problem must be linked to the last preceding event (which may be the first group event).

**5.5.14 Separator (label 14)**

Label 14 may be used as a separator between different parts of a message (information blocks). Some types of additional data fields are allowed only once per information block (see below), to avoid ambiguity separators can be helpful for terminals to make messages easier to understand for end-users, by grouping the message content syntactically. For instance, a terminal can use label 14 to make a short pause in spoken output.

**5.5.15 Other information as defined by sub-labels (label 15)**

Label 15 is used to refer to a further range of 64 sub-labels. The sub-labels indicate types of additional information defined as follows:

Label	Sub-label	Data field	Type of Information
15	0		Reserved for future use
15	1		Indicates that the following telephone number is available for users to call to receive telephone based information from an IVR service.
15	2		Indicates that the following telephone number is available for the user to report information to a service provider.
15	3-62		Reserved for future use
15	63		Reserved for future use

The Traveller Information Services Association (TISA) has agreed to coordinate requests to use sub-labels 3-62 in conjunction with label 15.

**5.5.16 Reference to telephone services (label 15, sub-label 1-2)**

Sub-labels 1 and 2 in conjunction with label 15 may be used to indicate that the following telephone number is available for users to call to receive telephone based information (sub-label 1), typically from an IVR service, or contribute information by telephone (sub-label 2).

This indication shall always be made as supplementary information to an event. The indication can be sent as supplementary information to a null event, to the event “travel information telephone service available” or to any other event, and can be sent with any location code, or with location code 65533 or 65534 for presentation as a general information message without any specific location reference.

e.g. “Travel information telephone service available. For more information call 1234 (£0.10 / min) “ or “Child abduction in progress. To report information call 911 (Free)”.

Table 1 describes the structure and order for the data fields to be sent within the free text of a multi-group message. The data fields are described in detail in the following sections.

**Table 1 — Structure of label 15, sub label 1-2 data**

Label: 15
Sub-Label: 1 or 2
Telephone number 1
Telephone number 2
...
Telephone number n
<option>
IVR option number 1

IVR option number 2
...
IVR option number n
<end>
Time unit of call cost
Numerical value of call cost
Currency lookup reference

**5.5.16.1 Telephone number**

Each telephone number shall be coded as a variable length string. By default the telephone number shall be defined using numbers. Each digit of each telephone number shall be coded as a 4 bit BCD (binary coded decimal) value with the addition of “+”, “\* “ and “#”. The value 14 shall indicate that following values are IVR menu option numbers. The value 15 shall be used to indicate the end of the telephone number or option information. The value 13 shall indicate that following values are not 4-bit BCD but 5-bit Alpha characters to allow representation of numbers such as “555-INFO”. These values are described fully in Tables 2 and 3.

**Table 2 — Numerical value coding in telephone numbers**

Telephone Digit	Coded value		Telephone Digit	Coded value	
0	0	0000	8	8	1000
1	1	0001	9	9	1001
2	2	0010	+	10	1010
3	3	0011	#	11	1011
4	4	0100	*	12	1100
5	5	0101	< Alpha>	13	1101
6	6	0110	<option numbers follow>	14	1110
7	7	0111	<end>	15	1111

**Table 3 — Alpha value coding in telephone numbers**

5 BIT CODE		Meaning (text displayed)	Dialled Number	5 BIT CODE		Meaning (text displayed)	Dialled Number
0	00000	<switch to numbers>		16	10000	P	7
1	00001	A	2	17	10001	Q	7
2	00010	B	2	18	10010	R	7
3	00011	C	2	19	10011	S	7
4	00100	D	3	20	10100	T	8
5	00101	E	3	21	10101	U	8
6	00110	F	3	22	10110	V	8
7	00111	G	4	23	10111	W	9
8	01000	H	4	24	11000	X	9
9	01001	I	4	25	11001	Y	9
10	01010	J	5	26	11010	Z	9
11	01011	K	5	27	11011	<space> for clarity only	Not Dialed
12	01100	L	5	28	11100	“.” (dash) for clarity only	Not Dialed
13	01101	M	6	29	11101	<Option Letters follow>	
14	01110	N	6	30	11110	<Option Numbers follow>	
15	01111	O	6	31	11111	<End of telephone number>	

e.g. To code “555-TRAFFIC” takes 61 bits:

5	5	5	<alpha>	“-“	“T”	“R”	“A”	“F”	“F”	“I”	“C”	<end>
5	5	5	13	28	20	18	1	6	6	9	3	31
4 bits	4 bits	4 bits	4 bits	5 bits	5 bits	5 bits	5 bits	5 bits	5 bits	5 bits	5 bits	5 bits

5.5.16.2 Time

The unit of time for the description of the call cost shall be defined with a code comprising 3 bits as in Table 4:

**Table 4 — Call cost time period coding**

Code		Meaning
0	000	Free
1	001	Per second
2	010	Per minute
3	011	Per hour
4	100	Per Call
5	101	Per Day (Multiple calls on any individual day, incur single cost)
6	110	Variable fees apply
7	111	(Undefined) not displayed

e.g.

- per minute; £1.50/min,
- per call ; £1/call

NOTE: the use of local currency symbols is explained in 5.5.16.3.

If the given unit of time defines the call as Free or subject to variable network charges then no further data is included in the transfer.

The receiver must provide suitable translations to display the call cost time periods in users' selected languages.

e.g.

- per minute, /min,
- per sec, /sec
- per call, each call
- Variable costs, Costs Vary, Variable Network Charges apply
- Free Call or Toll Free

5.5.16.3 Cost information

Cost shall be signalled using an integer value to define the digits and a decimal multiplier to provide correct adjustment to appropriate number of decimal places. Cost information shall not be sent if the call time period is free or variable.

An integer value shall be sent representing the numerical cost. The actual value shall be determined based on the multiplier - dividing the integer by 10 or 100 or 1000 to get the displayed cost value.

Multiplier	Cost	Pos	Currency
2 bits	14 bits	1 bit	1 byte

A total of 17 bits shall be used to code the cost value: decimal multiplier, cost, currency symbol and currency symbol position indicator.



Cost: integer value representing the cost (14 bits).

Decimal Multiplier: represents the decimal multiplier (2 bits):

value	meaning
0	integer
1	/10
2	/100
3	/1000

Currency Position: defines whether the currency symbol should be placed before or after the currency value. A value of '1' indicates the currency symbol shall be placed in front of the cost number, e.g. "\$25", "£1" or "GBP1.00". A value of '0' indicates the currency symbol shall be placed after the cost number, e.g. "1.20EUR" or "1GBP".

Currency Symbol: defines the currency symbol that shall be displayed, according to ISO 4217:2008 currency definition. Implementation within the receiver may either display the 3 alpha characters from the ISO 4217 currency definition or substitute the actual desired local character.

e.g. "GBP" or "£" could be shown for code number 049. "£1.20" can be coded as Multiplier = 2, Cost = 120, Position = 1 and Currency = 049.

## 6 Message management

### 6.1 General

The message management section deals with the message management functions of RDS-TMC. For the broadcaster, message management functions include message insertion, deletion, repetition, and updating. Similarly, in the terminal, message management functions include the identification of new messages and deletion of old ones, updating messages.

The ALERT-C protocol therefore defines the following items:

- system information;
- tuning information;
- message insertion;
- message repetition;
- message updating;
- message deletion; and
- control codes.

A distinction is made between user messages and system messages. User messages are those potentially made known to the end-user, as defined in the presentation section. System messages are of use only to the RDS-TMC terminal, for message management purposes.

## 6.2 System messages

### 6.2.1 General

Two types of system messages are defined:

- a) system information; and
- b) tuning information.

System information is conveyed in type 3A groups with the Application Identification (AID) for ALERT-C.

Tuning information is transmitted in the type 8A group in the variants:

(4) X3 - X0 = 0100 to (9) X3 - X0 = 1001 with X4 = 1.

They are described in detail in 7.5.3.

### 6.2.2 Location table

System information also is used to indicate the service ID of the transmitter and the location table to which the location codes in messages from this transmitter refer. Every database has place for location codes between 1 and 65535. However, the highest 2048 codes are reserved and are not available for national location codes:

0	reserved for future use
1..63487:	available for location coding
63488..64511:	special location codes for future extensions
64512..65532:	for INTER-ROAD messages (see 6.7)
65533..65535:	special codes (see 6.5.5)

The use of the bits in system information is described in 7.5.

Not all of the 64 possible location databases (each containing up to 65,536 locations) may be defined for each Location Table Country Code. Ranges of database numbers are defined in such a way as to prevent any ambiguity of location.

The RDS-TMC Service-ID indicates that RDS-TMC messages received from this transmitter can be used to update messages from all other transmitters having the same location database number and RDS-TMC Service-ID. Messages from transmitters with a different location database number and/or Service-ID must be updated independently.

NOTE EN ISO 14819-3 contains a list (table) of database numbers.

### 6.2.3 Terminal requirements

Although the basic message elements are bearer independent, this protocol describes the transmission via the RDS-system. This implies some limitations in channel capacity and terminal processing capacity, which must be reflected in some restrictions and requirements, which are detailed in 7.5.2.3.

Recognition of an RDS-TMC service shall be accomplished by detection of a RDS type 3A group carrying either AID CD46 or CD47. The type 3A group indicates the group used to carry RDS-TMC messages on that transmitter, which shall be type 8A groups.

A terminal is expected to be able to store in memory at least 300 RDS-TMC messages. Messages are required to be stored in the terminal until they cease to be valid, are updated or are deleted according to the procedures detailed in 6.4.

This maximum applies to all non-silent ALERT-C user messages; there is no reason to store silent cancellation messages, which serve only to delete a message as detailed in 6.5.4 below.

Service providers are expected to ensure that the number of RDS-TMC messages that they have transmitted which have not been specifically cancelled, or will have automatically expired, does not exceed the 300 maximum.

**NOTE** Not only should this maximum be respected from a single transmitter or group of transmitters carrying the same RDS-TMC service, but needs to be respected across an area served by adjacent and different RDS-TMC services, across which terminals could reasonably be expected to travel.

#### 6.2.4 Change of database numbers

Fundamental changes in the location table may (very occasionally) need a change of the database number on the transmitter side and a change of the corresponding database in the terminals.

If the default location table has to be changed, it is in the responsibility of the broadcaster to make sure that always a correct identification of the messages is possible. This changing may be done by using the following rules:

- the changing procedure shall only be done during the hour after midnight
- the transmitter information will be broadcast with the new database number starting at 00:00 hr.
- during this period all messages to be transmitted have to be coded following the INTER-ROAD concept (see 6.7)
- for messages generated before this period, which would expire after this period, an adaptation of their duration is necessary ensuring their expiration at midnight
- after this period INTER-ROAD messages shall be re-coded to normal messages if they refer to the new database number to conserve channel capacity
- multi-group messages with five groups should be avoided during this period, as it is not always possible to recode them entirely in INTER-ROAD messages
- INTER-ROAD messages referring to other database numbers are not affected by database number changes
- the “Foreign Location Table” code (see 6.7.2) must be decided on a per-message basis (e.g. location of the old database may be also in the new database).

These rules will ensure that all terminals will be notified about the location table number change. The terminal has no guarantee that all old messages will be maintained after change of database number.

If the Service-ID has to be changed, it can be done in a similar way as for the location table number. During the hour of change of Service-ID, the broadcaster has to delete all messages (with silent cancellation messages) from the old service, and only then may switch to the new Service-ID and insert new messages from the new service.

### 6.3 Message repetition

Messages may be inserted several (or many) times. This message repetition will serve to reduce acquisition time and improve reception reliability of urgent messages. The frequency of message repetition should increase as a function of broadcast message priority, as indicated in 4.7.

## 6.4 Message updating

At the transmitter, messages are updated simply by removing the old message from the cycle and inserting the new message as if it were a completely new one.

In the terminal, a new message overwrites an existing stored message if it:

- has the same primary location, drawn from the same location table, as the existing message **OR** the special location code 65535 **AND**;
- has the same value of the direction bit **AND**;
- contains an event that belongs to the same update class as any event (a multi-group message may have more than one event) in the existing message, **AND**;
- comes from the same RDS-TMC service. (i.e. a service with the same LTN and SID) as the existing message **AND**;
- if the message relates to a forecast event (update classes 32 – 39), the same duration.

Any user message not fulfilling **ALL** these conditions shall be treated as a separate new message, and have no effect on any message stored in the terminal.

Provided the conditions above are fulfilled, a multi-group message may update a single-group message and vice-versa.

In no circumstances should an incomplete multi-group message update or overwrite any elements of an existing stored message.

## 6.5 Message deletion

### 6.5.1 General

The following rules for message deletion apply to complete as well as incomplete messages existing in a terminal's memory.

Four mechanisms are provided for deleting messages from the memory of the terminals.

### 6.5.2 Message persistence

Messages are deleted if no refresh has been received within a specified persistence period, which is related to the duration.

For dynamic events, as defined in the Event List, the duration codes shall be interpreted as:

Code	Persistence period (after last receipt of the message)
0	15 minutes (no message to end-user)
1	15 minutes (with message to end-user)
2	30 minutes
3	1 hour
4	2 hours
5	3 hours
6	4 hours
7	until midnight on the day of message receipt

For information and silent events defined as longer period in the Event List, the duration codes shall be interpreted as:

Code	Persistence period
0	1 hour
1	2 hours
2	until midnight on the day of message receipt
3-7	until midnight on the day after message receipt

For forecast events defined as longer period in the Event List, the duration code shall be interpreted as:

Code	Persistence of message
0	1 hour
1	2 hours
2	until midnight on the day of message receipt
3-7	until midnight on the day after message receipt

If the available part of a message does not specify a duration or detailed stop-time, duration code 0 shall be assumed.

A multi-event message without a duration code or a detailed stop-time shall have a persistence period of 15 minutes if at least one of the events is defined as dynamic, otherwise it shall be 1 hour.

### 6.5.3 Detailed stop-time

RDS-TMC also provides for an alternative method of message management based on detailed stop-time. Where a detailed stop-time of the incident is known with reasonable certainty, a broadcaster can indicate the stop-time using codes defined in 5.5.8. In this case, the message is retained in memory until the detailed stop-time is reached, or until midnight on the day after message receipt (whichever is the sooner).

A message may contain both a stop time and a duration time. Then the stop-time or the duration or midnight on the day after message receipt (whichever is sooner) determines the persistence period.

### 6.5.4 Silent cancellation message

The Event list contains several non-silent (i.e. to be announced to the end-user) cancellation descriptions like "problem cleared". Messages with such an event code are handled as normal messages and obey the normal rules. The (spoken) announcement (see 6.6 on message presentation) shall be made whether or not an original message has been overwritten in the terminal.

The Event List also provides for one Silent Cancellation Message (SCM) per update class. Response to a SCM is governed by the same rules as for message updating, in that an existing message is only cancelled if it meets the stated criteria. A SCM must not contain any optional information. Therefore it shall not be a multigroup message except in case of silent cancellation of an INTER-ROAD message (see 6.7).

### 6.5.5 Null message

The special silent event value 2047 ("Null Message", see ISO 14819-2 and ISO 14819-3) and the special location code 65535 can be used for three more general types of silent cancellation messages:

- a) The message uses the event value 2047 and the location code 65535. This message can be used as a general cancellation message to do a full cancellation of all messages that comes from the same RDS-

TMC service as defined by AFI = 1 or when the message comes from a non-conflicting service referenced with the tuning variants 6, 7, 8 or 9.

- b) The message uses the event value 2047 and any location code. This message can be used as a general cancellation message to do a full cancellation of all messages for that location code that comes from the same RDS-TMC service as defined by AFI=1 or when the message comes from a non-conflicting service referenced with the tuning variants 6, 7, 8 or 9.
- c) The message uses a silent cancellation event and location code 65535. This message can be used as a general cancellation message to do a full cancellation of all messages with an event code in the same update class as the silent cancellation event that comes from the same RDS-TMC service as defined by AFI = 1 or when the message comes from a non-conflicting service referenced with the tuning variants 6, 7, 8 or 9.

## 6.6 Message presentation

With respect to the presentation of messages to the user, the protocol recommends (and, in fact, assumes) the following terminal functions:

- a) On user request, all validated non-silent messages existing (completely or partially) in the terminal's memory at that moment, shall be presented. Extremely urgent messages must be presented first, followed by urgent and, finally, normal-urgency messages.
- b) Each newly (completely or partially) received, non-silent and urgent or extremely urgent message shall automatically and as soon as possible after receipt be presented, unless it is identical to (a part of) a message existing already in memory.

Information obtained from a not validated or unlinked message group shall never be presented.

Immediate presentation as described in b) may be suppressed if the presentable contents of the new message do not differ from the presentable contents of an overwritten message.

New extremely urgent messages have priority over those messages awaiting presentation.

In both functions a) and b), presentation of a message may be suppressed (or postponed) by user-selectable options such as a specific service or selected, geographic or urgency 'filters', 'mute' functions, etc. In some cases presentation of partially received messages is forbidden by the protocol, e.g. for INTER-ROAD messages at least the first two message groups must be available.

It is recommended that presentation as described in a) follows not only upon an explicit user request, but also upon a switch to another geographic selection filter, the cancelling of a 'mute' function and similar changes of 'mode'.

## 6.7 Out of area referencing

### 6.7.1 Structure of the INTER-ROAD concept

RDS-TMC messages normally refer to locations from the default location table for the transmitter (see 6.2.2). It is, however, also possible to reference locations from other tables via special multi-group messages: so called 'INTER-ROAD messages' (see 6.7.2). These messages can be used to inform end-users about problems in other areas, in particular in neighbouring countries.

In INTER-ROAD messages, each location is uniquely specified by adding the Location Table Country Code and Location Table Number to the original location code (the 16-bits location code itself can be used in every table and is therefore not unique). In the terminal, such an extended location code can be interpreted by means of a 'INTER-ROAD database', which is, in principle, a composition of (parts of) all or most national databases. In practice, a manufacturer may choose to compose it from any group of RDS-TMC location databases that are of interest for end-users to be combined.

The complete reference to a location in an INTER-ROAD database is the sequence: Location Table Country Code (4-bits) / Location Table Number (6-bits) / location code (16-bits).

### 6.7.2 INTER-ROAD messages

INTER-ROAD messages can and will be transmitted mixed with the transmission of normal RDS-TMC messages. It will not be necessary to have separate transmitting sessions.

An INTER-ROAD message can be recognised by the location field in the first message group, which is filled with a specific Foreign Location Table (FLT) Code. As a consequence INTER-ROAD messages always have a minimum of two RDS-TMC groups and messages with five RDS-TMC groups cannot entirely be transformed into an INTER-ROAD message.

- The 16-bits FLT Code in the location field is the key to the right part in the INTER-ROAD database. The FLT Code is composed of: 6-bits set to "1", followed by a 4-bits Location table country code and a 6-bits Location table number.
- As the reference in the INTER-ROAD database is LTCC/LTN/location, the first part of it is now fixed by the FLT Code in the location field.
- A number range of locations - from 64512 to 65532 - will be reserved in each TMC location table for the FLT Codes.
- In the second message group the terminal will find the code for the actual primary location related to the event. This location code is given in bits Y11 - Z12 (see 7.6.2), without preceding label. The remainder of the second group and any additional groups can be used for optional information coded in free format as described in 5.5.

Any other location code in the message, i.e. each code preceded by label 10, 11 or 13 (see 5.5) and the secondary location code implied by the extent code (see 5.3.4.3), refers to the same foreign location table as the primary location. An INTER-ROAD message can be interpreted if, in the terminal, the appropriate (part of the) foreign location table has been inserted/installed, either as a single database or (more likely) as part of an INTER-ROAD database. If the terminal cannot find both the primary and the secondary location in its database(s), it shall produce no message output to the user.

### 6.7.3 Updating and cancellation of INTER-ROAD messages

The updating rules of 6.4 fully apply to INTER-ROAD messages. Thus, an INTER-ROAD message can only be updated or refreshed by an INTER-ROAD message with the same primary location from the same foreign location table. INTER-ROAD messages are associated with the same service ID (see 6.2.2) as normal messages coming from the same transmitter. Silent cancellation of an INTER-ROAD message can be done by a Silent Cancellation Message (see 6.5.4) within its first group the FLT code and in its second group the primary location code of the INTER-ROAD message(s) to be cancelled. Similarly, the "Null Message" described in 6.5.5 under b) can be applied to a foreign location.

A message with the special location code 65535 in its first group overwrites (or, in case of a SCM, cancels) all messages, including all INTER-ROAD messages, within the same update class and from the same RDS-TMC service (see 6.4 and 6.5.5). The restriction on update class can be lifted by the use of event code 2047 (see 6.5.5, under a).

If code 65535 is given in bits Y11 - Z12 of the second group of a INTER-ROAD message, the updating and cancellation rules in 6.4 and 6.5.5 shall only be applied to INTER-ROAD messages with the same FLT code.

Example: an INTER-ROAD message with event code 2047 in its first group and location code 65535 in its second group cancels all INTER-ROAD messages with the same FLT code and from the same service.

As a consequence, a RDS-TMC service wishing to do a cancellation of all messages concerning locations from its own default location database, but not of non-expired INTER-ROAD messages, must do this by an

INTER-ROAD SCM (Silent Cancellation Message) with its own FLT code (i.e. own Location table country code and Location table number) in its first group, and code 65535 in its second group.

## 7 Transmission

### 7.1 General

The transmission section of RDS-TMC conveys the messages over-air. This section specifies the mapping of the messages defined by the presentation and message management sections into the RDS groups of the network and lower layers. At this level we also provide identification of the number of RDS groups used to convey each message and codes to identify, link and synchronise sequences of two or more groups.

### 7.2 Format of type 8A groups

RDS-TMC information is conveyed in RDS type 8A groups. Figure 2 shows the format of type 8A groups that are used to convey all RDS-TMC messages. Transmitter Information messages are also broadcast using only one group.

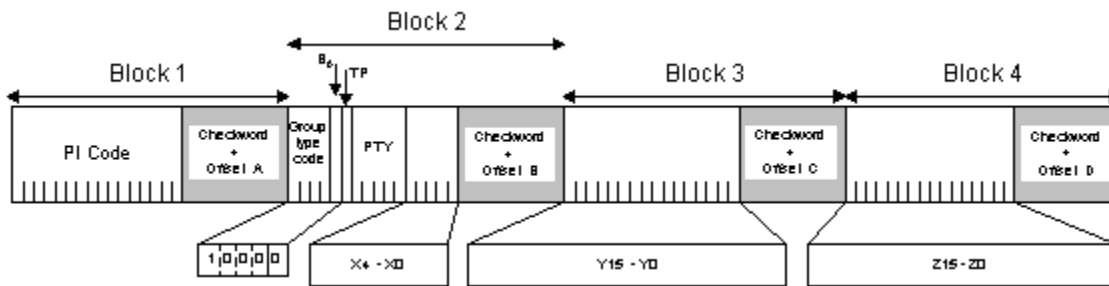

Figure 2 — RDS type 8A groups, showing the bit and block structure, defined for RDS-TMC

Sequences of two or more type 8A groups are used to convey additional information from the optional message content defined in 5.5. Each multi-group RDS-TMC message comprises a first group with basic information, which is always sent, first, followed by the other groups, in sequence. The maximum number of groups comprising any one RDS-TMC message is five.

### 7.3 Immediate repetition

ALERT-C assumes that periodic message repetition in the message management section (see 6.3) will be complemented by immediate repetition of each group in the transmission. Each group shall be sent at least twice in succession, before the next group is sent.

It is recommended that groups are accepted as valid only after two bit-by-bit (for the TMC-bits, except the continuity index) identical copies of the same group have been received, either through transmission or message repetitions. The use of the RDS error correction is up to the manufacturer of a terminal.

For multi-group messages, the first group is repeated, then the second, etc. If, for example, there are three groups in Message A (A1, A2, A3) and two in Message B (B1, B2) the immediate repetition sequence is:

A1 A1 A1 A2 A2 A2 A3 A3 A3 B1 B1 B1 B2 B2 B2 C...

RDS groups other than type 8A groups can come in between immediate repetitions, but no other type 8A group shall do so.



### 7.4 Single-group user messages

Single-group user messages are indicated in the transmission section by two bits in Block 2, bit X4 and the single-group user message identifier (bit X3). These bits are defined as follows for single-group messages:

X4	X3
0	1

Type 8A groups constituting single-group messages may follow any other type of RDS group without restriction (see 7.5.2.3 for details of timing between two 8A groups).

Bit X4 = 1 is used for tuning information and for future use.

The TMC data fields in a message were defined in 5.3 as:

1. event (11 bits);
2. location (16 bits);
3. direction (1 bit)
4. extent (3 bits);
5. duration (3 bits); and
6. diversion advice (1 bit).

These message data fields are carried within single-groups as follows:

**Table 5 — TMC data fields carried within single-groups**

Data field	MSB	LSB
duration/persistence	X2	X0
diversion advice	-	Y15
direction	-	Y14
extent	Y13	Y11
event	Y10	Y0
location	Z15	Z0

The data field bit allocations are illustrated in Figure 3.

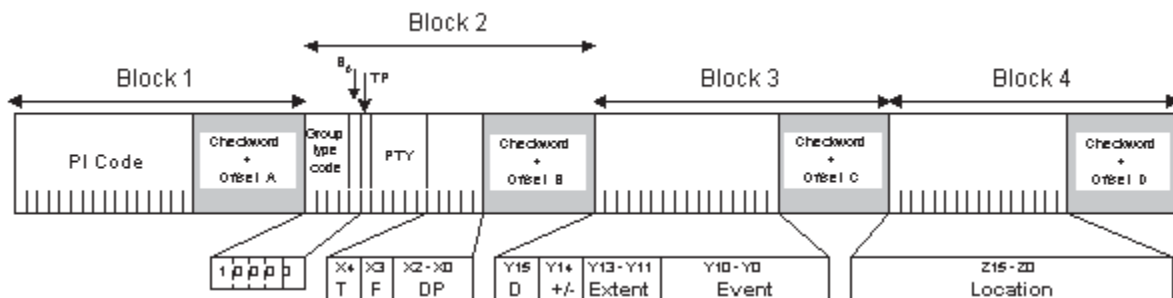

**Figure 3 — RDS-TMC single-group full message structure**

Key: T = 0 indicates User message;  
T = 1 indicates Tuning Information (or reserved for future use)

F = 0 indicates multi-group message;  
F = 1 indicates single-group message

DP = Duration and Persistence values

D = 0 indicates no diversion is recommended  
D = 1 indicates that drivers are advised to follow the indicated diversion

+/- = 0 indicates positive direction  
+/- = 1 indicates negative direction

## 7.5 System messages

This section covers very complex, inter-related parameters and requires very careful consideration when establishing a service and designing terminal products. Advice and consultation with the “TMC community” should be sought before proceeding.

### 7.5.1 General

Two types of system message are currently defined:

- System information; and
- Tuning information

### 7.5.2 System information

#### 7.5.2.1 Introduction

RDS-TMC is defined within the overall RDS system to use an Open Data Application (ODA), which inherently requires RDS type 3A groups to signal the presence of RDS-TMC. By definition each ODA is allocated an application ID and additionally in the case of RDS-TMC the fixed group type 8A is used.

Two application ID's are assigned for TMC operational services: CD46 and CD47. These two ODA's and associated application ID's differ in the rules under which the identification of the Location Table parameters shall be transmitted.

One application ID is assigned for TMC testing of (CD46 or CD47 based) services: OD45. OD45 transmissions are for test purposes only. Normal, production version, TMC terminals shall ignore TMC transmissions with this application ID.

The RDS type 3A group has capacity which the application itself may use for additional information as described in the following section.

The System Information enables an RDS-TMC product to decode and evaluate essential data, which describes the transmission being received. The System Information indicates an RDS-TMC service and comprises some service characteristics needed to select the RDS-TMC service.

#### 7.5.2.2 Format of the System Information in the type 3A group

The System Information shall be transmitted in variants 0 (00) and 1 (01), always and 2 (10) of Block 3 of the type 3A group (See Figure 4). The variant 2 (10) is optional for ODA CD46 and mandatory for ODA CD47. The System Information shall be transmitted in variants 0 (00) and 1 (01) of Block 3 of the type 3A group (See Figure 4).

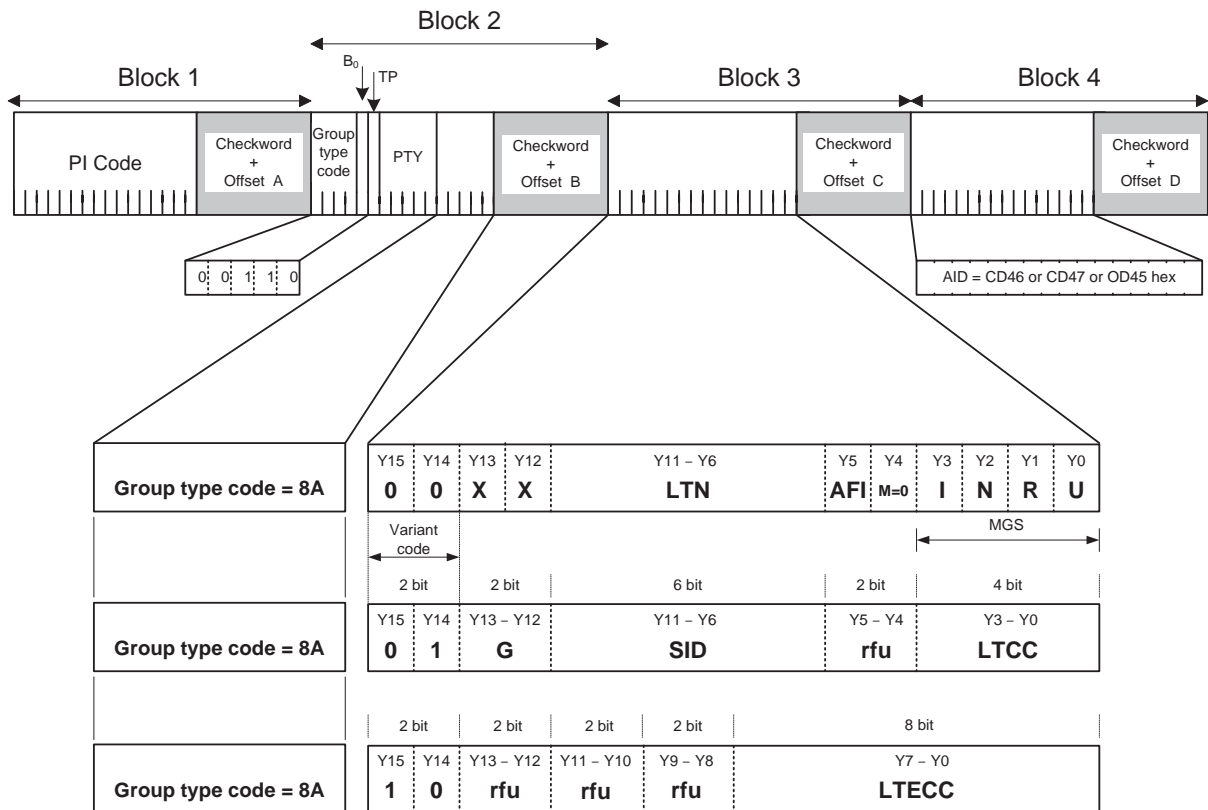

Figure 4 — RDS type 3A group structure, RDS-TMC carrying system information

- Key:
- LTN = Location Table Number (6 bits)
  - LTCC= Location Table Country Code (4 bits)
  - AFI = Alternative Frequency Indicator (1 bit)
  - MGS = Message Geographical Scope (total of 4 bits)
  - I = International (INTER-ROAD) (1 bit)
  - N = National (1 bit)
  - R = Regional (1 bit)
  - U = Urban (1 bit)
  - SID = Service Identifier (6 bits)
  - G = Gap parameter (2 bits)
  - M = Mode of Transmission (1 bit) *to be set to 0 always ('basic mode')*
  - LTECC = Location Table Extended Country Code (8 bits)

NOTE Service Providers shall set all 'rfu' bits to 0 in transmissions according to this part of ISO 14819.

### 7.5.2.3 System Information

The supplied System Information comprises the LTCC (Location Table Country Code), LTN (Location Table Number), an AFI (Alternative Frequency Indicator), a MGS (Message Geographic Scope), and a SID (Service Identifier). Additionally for ODA CD47 the LTECC (Location Table Extended Country Code) is supplied always, and is optional for ODA CD46.

The LTCC, LTN combinations assigned to each country are given either in ISO 14819-3, or, when not, allocated by TISA. With ODA CD47 a service provider is free to set the field LTCC independent of the value of the Country Code in the PI code (first nibble of the PI code, PICC). The LTECC value assigned to each country for purposes of location table identification are identical to the ECC value per country as given in IEC 62106

## ISO 14819-1:2013(E)

With ODA CD46 the value of the LTCC field shall be set equal to the value of the PICC, unless a signed license agreement with TISA ([www.tisa.org](http://www.tisa.org)) is in place specifying the terms and conditions under which a requesting service provider may differ the value of LTCC and PICC in the System Information of its transmission. Rationale for this restriction is backwards compatibility of terminals built under prior versions of EN ISO 14819 (2003 and before). Terminals are recommended only to accept a CD46 service with LTCC unequal to PICC, when a TISA license agreement is in place, as published on the TISA web site at time of manufacture of the terminal.

If all frequencies of programme network (equal PI code) carry the same RDS-TMC service, then the AFI should be set to AFI = 1. In all other cases the AFI should be AFI = 0.

The four bits of the MGS (Message Geographical Scope) indicate the geographical relevance of the RDS-TMC service.

The definition of the geographical relevance is as follows:

- International (I = 1): in addition to national (see below) gives strategic INTER-ROAD messages for at least the major events in neighbouring countries.
- National (N = 1): covers at least all strategic information for at least the transmitter broadcast area and national wide continuity is guaranteed (e.g., by AFI and/or tuning information). Example: a national service would be, e.g. a service covering all Germany.
- Regional (R = 1): gives tactical information for at least all motorways in the region and all other major roads of regional importance Example: a regional service would be, e.g., the WDR, covering only North Rhine Westphalia)
- Urban (U = 1): covers at least all major (through going) axes, ring roads etc. in the broadcasting area, gives more roads and more details than a regional service.

The SID identifies the data service provider as defined in the introduction. SID should uniquely be assigned on a national level. Meaning of the Service-ID code transmitted:

- 0 = general service;
- all other numbers = specific service.

The terminal contains a list of all acceptable Service-IDs, these have the following meanings:

- 0 = accepts a service from any station; or
- all other Service-IDs = tune to the service specified.

The Service-ID is linked to the Location Table Country Code (LTCC) & Location Table Extended Country Code (LTECC).

Service providers will be allocated an SID in the range 1 – 63 by a coordinating authority. SID = 0 is reserved for general services which will allow terminals to receive information for traffic safety reasons.

### 7.5.2.4 RDS-TMC transmission modes

A particular RDS-TMC service across an area or country will most likely use a network of transmitters, which may or may not correspond to the network used to provide an audio service. Like the RDS audio receiver, the RDS-TMC terminal will need to evaluate frequencies and switch to the transmitters providing the optimum signal for the required service. In order that a terminal may evaluate alternative frequencies for the RDS-TMC service without losing any of the ALERT-C messages, minimal and predictable gaps between successive RDS-TMC groups in the data stream should be created. The terminal can exploit these gaps for frequency evaluation and re-tuning.

The size of the gaps required is dependent on the functions the RDS-TMC terminal has to carry out. If the RDS data stream provides the RDS-TMC terminal with a list of 'alternative frequencies' on which the same and immediately adjacent RDS-TMC services are carried, relatively short gaps in which frequency evaluation may take place are sufficient. If however, a terminal is required to carry out a PI code search, longer gaps are required.

The transmission of RDS-TMC within the RDS data stream shall be arranged so that 'short' gaps between any two types 8A groups are always present – the so-called 'Basic Mode'. Formerly, an additional transmission mode, the 'Enhanced Mode' (now withdrawn with this specification), was intended to suppress entirely the transmission of type 8A groups at regular and predictable times, to create extended gaps between successive type 8A groups.

#### 7.5.2.5 The basic mode

The basic mode is indicated by setting Mode bit 'M' (Y4) in the type 3A variant 0 group to '0'.

The minimum value for the 'Basic' inter-8A gap is given by the value of the parameter 'G' transmitted in the type 3A variant 1 group, so that between two successive 8A groups there shall be a number of  $n$  non-8A groups, with  $n \geq G$ . The parameter G is coded by bits Y13 and Y12. These two bits allow for four alternative inter-8A group gap sizes to be signalled as in Table 19 below, which also shows the corresponding maximum average number of type 8A groups transmitted for each gap size.

**Table 6 — Coding of gap parameter G**

Binary Code Y13 Y12	Gap value G <sup>1</sup>	Group rate <sup>2</sup> (groups/s)
00	3	2.85
01	5	1.90
10	8	1.27
11	11	0.95
<sup>1</sup> Gap value = minimum number of non 8A groups between two 8A groups <sup>2</sup> Group rate = maximum theoretical average rate for the 8A type groups		

NOTE: that in addition to using the transmitted value of G, the terminal may also be able to implicitly determine the inter-TMC message group (8A group) gap from examination of the data stream.

NOTE: that although it is possible to transmit an average of up to 2.85 TMC message groups/second, not more than 2.5 of these should be 'user messages' to limit the required processing capabilities in the terminal.

#### 7.5.2.6 The enhanced mode

Enhanced mode is withdrawn with this version of the specification. Only basic mode is supported (indicated by Mode bit 'M' (Y4) in the type 3A variant 0 group to '0').

#### 7.5.2.7 System Information Repetition rates

The 3A group variants 0 and 1 contain the System Information for the TMC service and shall be transmitted always. These two 3A group variants 0 and 1 may be injected at any position of the sequence, but with a minimum transmission rate of one 3A group variant 0 or 1 every 10 seconds, a maximum transmission rate of one 3A group variant 0 or 1 every second, and a maximum jitter of  $\pm 2$  RDS groups.

The 3A group variant 2 may contain additionally the LTECC for the TMC service.

This 3A group variant 2 may be injected at any position of the sequence, but with a minimum transmission rate of one 3A group variant 2 every minute, and a maximum transmission rate of one 3A group variant 2 every second.

7.5.3 Tuning information

7.5.3.1 General

As described above, an RDS-TMC terminal will need to change from one transmitter to another at boundaries of a particular transmitter’s coverage. Each transmitter should direct the RDS-TMC terminal to specific frequencies or TMC services in adjacent areas.

Where the *same* RDS-TMC service is *only* carried by all transmitters in the same (or generically related) audio programme service (AFI=1), the frequencies transmitted in the type 0A groups should be used to identify suitable frequencies.

In all other cases, appropriate variants within RDS-Tuning Information are used; either on their own or in combination with frequency information transmitted in EON type 14A group variants.

7.5.3.2 Format of the Tuning Information

The Tuning Information for RDS-TMC is transmitted in the type 8A group in the variants (4) 0100 to (9) 1001 under X4 = 1. (The remaining variants (0 to 3 and 10 to 15) are reserved for future use. Future development of the ALERT-C protocol should be done using these remaining variants, or the type 8A group with X4 = 0, or by using an additional AID for transmission of additional data.

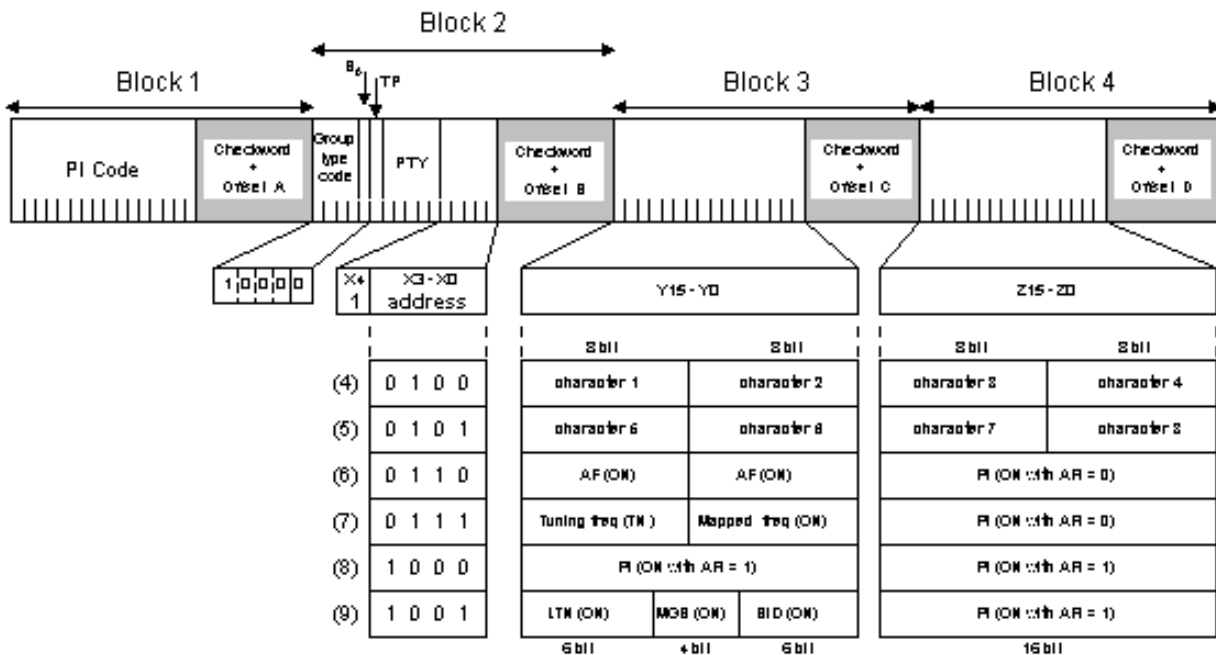

Figure 5 — Format of RDS-TMC tuning information

**Variants 4 and 5** allow the transmission of an eight-character TMC service provider name. The character repertoires to be used are given in Annex E of IEC 62106. The information transmitted shall be static.

**Variant 6** provides **specific** frequencies to be used for the continuation of the *same* RDS-TMC service carried on a network with a different PI code, which is indicated in Block 4. The transmission of AFs follow the practice described in IEC 62106, Section 3.2.1.6. Several variant 6 groups may need to be transmitted, although good RDS practice suggests that the number of groups to be transmitted should be limited by including only the frequencies of neighbouring transmitters as in IEC 62106, Section 3.2.1.6.2.

**Variante 7** provides mapped frequency pair information for the TMC network. The terminal should only use the Mapped frequency (ON) if tuned to the corresponding Tuning Frequency (TN). The PI code of the Other Network is given in Block 4. Several variant 7 groups may need to be transmitted.

**Variante 8** is used to indicate the PI codes of the adjacent programme services on which the *same* RDS-TMC service is carried. All transmitters within the referenced network should carry the RDS-TMC service.

Variants 6, 7 and 8 may contain a list of Tuning Information (e.g. several AF(ON)/PI(ON)). In case of an odd number of frequencies in variant 6 the list should be completed with a filler code (code 205). In case of an odd number of PI codes in variant 8, one PI code may be transmitted twice or PI = 0 should be added to complete the list.

**Variante 9** provides the PI(ON) codes of Other Networks with different system parameters (database-ID, MGS-parameters, Service-ID). If both services contain a common part of the message set, they are allowed to update each other (If Location Table Number and/or Location table country code are different, such an updating is only possible via the INTER-ROAD mechanism). One way downward referencing is not allowed with this variant.

### 7.5.3.3 Conditions for using Tuning Information

The variants 6, 7, 8 and/or AFI = 1 (TN) shall only be used by broadcasters if the tuned and the referenced frequency fulfil the following conditions:

- same LTN and LTCC;
- same SID;
- non-conflicting message content (services may update each other in the common part of the message set);
- same N-bits of MGS;
- same transmission mode parameters; and
- service has to be 24 hour-service if indicated as national and/or international.

The variant 9 shall only be used by broadcasters if the tuned and the referenced frequency fulfil the following conditions:

- non-conflicting message content (services may update each other in the common part of the message set);
- one way downward reference is not allowed; and
- if LTN or/and Location Table Country Code (CC) differ, updating may be done only by INTER-ROAD.

Maximum 32 variants of 6, 7, 8 and 9 together shall be used.

Note: in order to optimise the automatic tuning processes in the RDS-TMC terminal, ideally the number of frequencies and PI codes referenced in the Tuning Information should be limited to those for the immediately adjacent areas.

### 7.5.3.4 Repetition rate

All tuning information for the *same* RDS-TMC service should be transmitted at least once every two minutes, and for *different* services, once every ten minutes. As tuning information data on any single transmitter should be static, no immediate repetition of tuning information groups is required.

## 7.6 Multi-group messages

Multi-group messages are sequences of between two and five type 8A groups which constitute a detailed RDS-TMC message.

All multi-group messages contain a three-bit continuity index field X2-X0 the purpose of which is to help distinguish between different multi-group messages. All groups within any particular multi-group message shall contain the same value of this continuity index. The continuity index is maintained constant throughout each of a message's immediate transmission repetitions, but not necessarily the periodic message repetition.

The continuity index must be incremented for each subsequent multi-group message even if it is the periodic repetition of itself. Six values are defined in total for the continuity index, from 001 to 110 inclusive. The values 000 and 111 are reserved for other functions.

When the index has reached 110, its next value shall be 001.

RDS-TMC message insertion should be arranged in such a way that:

- each multi-group message is fully transmitted, including immediate repetitions, within fifteen seconds (i.e. at the lowest of the four defined TMC transmission rates, a five-group message, originated and repeated twice, with an inter-type 8A group gap of eleven groups requires a total of 169 groups – requiring 14.82 seconds);
- any given value of the continuity index must not re-occur in a different message within a period of 15 seconds (at higher transmission rate with shorter multi-group messages, this period must also be respected).

In the terminal subsequent groups shall be **linked** to a first group if:

- the first group, second group and (where relevant) any subsequent groups are each correctly received at least **once** within any fifteen second period; **AND**
- the continuity index has the same value in all the groups being linked; **AND**
- the group sequence identifier shows that there are no missing **intermediate** groups in the message. (Missing groups at the end of a message shall not prevent linking of two or more initial groups).

Before being presented to the end-user, any group must also have been **validated** (received identically, at least twice) as specified in 7.3. Linking is required for at least **one** of the copies. Validation of each group (for which error correction is allowed) may occur before, during or after reception of the linked sequence.

When the first two or more groups of a multi-group message have been received, linked and validated, without having linked and/or validated one or more subsequent groups, any additional information (labels plus data fields), which is complete, shall be presented to the end-user. If, however, the last correctly received group ends with one or more detailed diversion instructions, no part of the diversion shall be presented until the whole diversion has been correctly received.

### 7.6.1 First group

The first group of a multi-group message is indicated in the transmission section by the bit X4 (see 7.4), the single-group message identifier (bit X3) defined in 7.4, and by the first group indicator (bit Y15). For the first group of multi-group messages, these bits are defined as:

X4	X3	Y15
0	0	1

Type 8A groups constituting the first group of multi-group messages may follow any type of RDS group, without restriction.



The TMC data fields in the first group of a multi-group message comprise:

- a) event description (11 bits);
- b) location (16 bits); and
- c) direction and extent (4 bits).

These three fields (see Table 6) are mapped into type 8A groups in exactly the same way as for single-group messages (see 7.4). Thus the bit allocations are as illustrated in Table 7:

**Table 7 — RDS-TMC data fields - First group**

Data field	MSB	LSB
continuity index	X2	X0
direction	-	Y14
extent	Y13	Y11
event	Y10	Y0
location	Z15	Z0

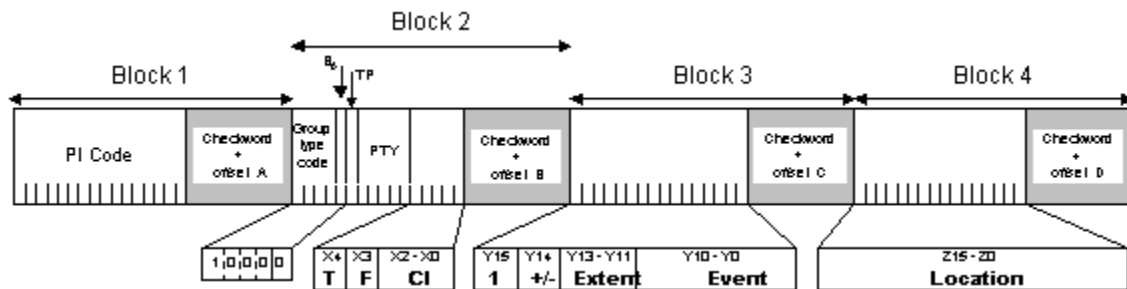

**Figure 6 — RDS-TMC multi-group message - first group**

- Key:
- T = 0 indicates User message;
  - T = 1 indicates Tuning Information (or reserved for future use)
  - F = 0 indicates multi-group message;
  - F = 1 indicates single-group message
  - CI = Continuity Index values;
  - +/- = 0 indicates positive direction;
  - +/- = 1 indicates negative direction.

Where only the first group of a multi-group message has been correctly received and verified, RDS-TMC terminals may present the event, location and extent information to the end-user, together with a warning that further details of the event may follow. Further details shall be given on receipt, linking and verification of the subsequent message groups. This is not the case for INTER-ROAD and other reserved location codes, where at least the first two groups must have been received, linked and verified for a correct partial message presentation to the user.

**7.6.2 Subsequent groups**

Subsequent groups of multi-group messages are indicated in the transmission section by the bit X4, the single-group message identifier bit X3, and the first group indicator bit Y15, as follows:

X4 X3 Y15  
0 0 0

Subsequent groups of multi-group messages are distinguished from service messages by the fact that the continuity index field (X2-X0) is not assigned the value 000.

The message re-assembly requirement is met by defining Y14 as the second group indicator (value 1 in the second group, 0 in any subsequent groups); and bits Y13-Y12 as a group sequence identifier, which counts down from (N minus 2) to zero for an N group message. Y12 is the least significant bit. Thus, the group sequence identifier equals (N minus 2) in the second group, and zero in the last. The maximum value permitted for N is 5.

Thus the bit allocation for subsequent groups of multi-group messages is as follows ( see Table 8):

**Table 8 — RDS-TMC data fields - subsequent groups**

Data field	MSB	LSB
continuity index	X2	X0
second group indicator	-	Y14
group sequence identifier	Y13	Y12
free format	Y11	Z0

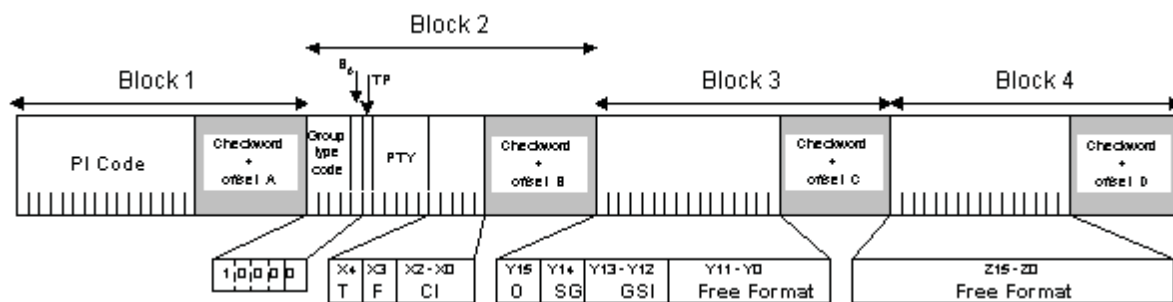

**Figure 7 — RDS-TMC multi-group message - subsequent group structure**

- Key:
- T = 0 indicates User message;
  - T = 1 indicates Tuning Information (or reserved for future use);
  - F = 0 indicates multi-group message;
  - F = 1 indicates single-group message;
  - CI = Continuity Index values;
  - SG (Second Group) = 0 indicates third, fourth, or fifth group;
  - SG (Second Group) = 1 indicates second group;
  - GSI = Group sequence values.

Therefore subsequent groups of multi-group messages each provide 28 bits of free-format coding space in Blocks 3 and 4 for the optional message labels and data fields defined in the presentation and message management sections (see Sections 5 and 6). Bit Y11 is the most significant bit, and Z0 the least significant bit.

The first 4-bit label is coded in bits Y11-Y8 of Block 3, followed immediately by the data field of length defined in 5.5. Where a second 4-bit label is required, this continues immediately.

If the total number of bits required for labels and data fields is greater than 28, coding continues without interruption at bit Y11 of a subsequent group. If the total number of bits required for labels and data fields

equals 28, no further bits need be transmitted. If the total number of bits required for labels and data fields is less than 28, all unused bits (which will be the least significant bits) shall be set to zero.

In an INTER-ROAD message, the optional information labels and data fields start at bit Z11 of the second group.

**7.7 Summary of X-bit usage in RDS-TMC type 8A groups**

X4	X3-X0	Y15-Y0, Z15-Z0
0	0000 (0)	<i>Reserved for future use</i>
0	0001 (1)	ALERT-C multi-group
0	0010 (2)	ALERT-C multi-group
0	0011 (3)	ALERT-C multi-group
0	0100 (4)	ALERT-C multi-group
0	0101 (5)	ALERT-C multi-group
0	0110 (6)	ALERT-C multi-group
0	0111 (7)	<i>Reserved for future use</i>
0	1000 (8)	ALERT-C single-group
0	1001 (9)	ALERT-C single-group
0	1010 (10)	ALERT-C single-group
0	1011 (11)	ALERT-C single-group
0	1100 (12)	ALERT-C single-group
0	1101 (13)	ALERT-C single-group
0	1110 (14)	ALERT-C single-group
0	1111 (15)	ALERT-C single-group
1	0000 (0)	<i>Reserved for future use</i>
1	0001 (1)	<i>Reserved for future use</i>
1	0010 (2)	<i>Reserved for future use</i>
1	0011 (3)	<i>Reserved for future use</i>
1	0100 (4)	ALERT-C tuning information
1	0101 (5)	ALERT-C tuning information
1	0110 (6)	ALERT-C tuning information
1	0111 (7)	ALERT-C tuning information
1	1000 (8)	ALERT-C tuning information
1	1001 (9)	ALERT-C tuning information
1	1010 (10)	<i>Reserved for future use</i>
1	1011 (11)	<i>Reserved for future use</i>
1	1100 (12)	<i>Reserved for future use</i>
1	1101 (13)	<i>Reserved for future use</i>
1	1110 (14)	<i>Reserved for future use</i>
1	1111 (15)	<i>Reserved for future use</i>

Vertical line of small characters or artifacts.

---

---

**ICS 03.220.20; 35.240.60**

Price based on 43 pages