

INTERNATIONAL STANDARD

ISO 14743

First edition
2004-05-01

Pneumatic fluid power — Push-in connectors for thermoplastic tubes

*Transmissions pneumatiques — Raccords instantanés pour tubes
thermoplastiques*



Reference number
ISO 14743:2004(E)

© ISO 2004

PDF disclaimer

This PDF file may contain embedded typefaces. In accordance with Adobe's licensing policy, this file may be printed or viewed but shall not be edited unless the typefaces which are embedded are licensed to and installed on the computer performing the editing. In downloading this file, parties accept therein the responsibility of not infringing Adobe's licensing policy. The ISO Central Secretariat accepts no liability in this area.

Adobe is a trademark of Adobe Systems Incorporated.

Details of the software products used to create this PDF file can be found in the General Info relative to the file; the PDF-creation parameters were optimized for printing. Every care has been taken to ensure that the file is suitable for use by ISO member bodies. In the unlikely event that a problem relating to it is found, please inform the Central Secretariat at the address given below.

© ISO 2004

All rights reserved. Unless otherwise specified, no part of this publication may be reproduced or utilized in any form or by any means, electronic or mechanical, including photocopying and microfilm, without permission in writing from either ISO at the address below or ISO's member body in the country of the requester.

ISO copyright office
Case postale 56 • CH-1211 Geneva 20
Tel. + 41 22 749 01 11
Fax + 41 22 749 09 47
E-mail copyright@iso.org
Web www.iso.org

Published in Switzerland

Contents

Page

Foreword	iv
Introduction	v
1 Scope	1
2 Normative references	1
3 Terms and definitions	1
4 Performance requirements	1
4.1 Material	1
4.2 Pressure and temperature	2
5 Features	2
6 Outside diameter of tube	2
7 Design	3
8 Marking	7
9 Performance requirements and testing	7
9.1 General	7
9.2 Test samples	7
9.3 Tensile test	8
9.4 Proof and burst pressure test (for polyamide tubing only)	8
9.5 Connecting force test	9
9.6 Disconnecting force test	10
9.7 Leakage test (to be performed before disconnecting)	10
9.8 Cyclic endurance (impulse) test with vibration (for polyamide tubing only)	13
10 Designation	15
11 Identification statement (reference to this International Standard)	16
Annex A (normative) Polyamide tubes for testing	18
Annex B (normative) Polyurethane tubes for testing	20
Bibliography	22

Foreword

ISO (the International Organization for Standardization) is a worldwide federation of national standards bodies (ISO member bodies). The work of preparing International Standards is normally carried out through ISO technical committees. Each member body interested in a subject for which a technical committee has been established has the right to be represented on that committee. International organizations, governmental and non-governmental, in liaison with ISO, also take part in the work. ISO collaborates closely with the International Electrotechnical Commission (IEC) on all matters of electrotechnical standardization.

International Standards are drafted in accordance with the rules given in the ISO/IEC Directives, Part 2.

The main task of technical committees is to prepare International Standards. Draft International Standards adopted by the technical committees are circulated to the member bodies for voting. Publication as an International Standard requires approval by at least 75 % of the member bodies casting a vote.

Attention is drawn to the possibility that some of the elements of this document may be the subject of patent rights. ISO shall not be held responsible for identifying any or all such patent rights.

ISO 14743 was prepared by Technical Committee ISO/TC 131, *Fluid power systems*, Subcommittee SC 4, *Connectors and similar products and components*.

Introduction

In pneumatic fluid power systems, power is transmitted and controlled through air under pressure within a circuit.

Components are connected through their ports by means of connectors (fittings) and conductors.

Pneumatic fluid power — Push-in connectors for thermoplastic tubes

1 Scope

This International Standard specifies the general requirements and test methods for the design and performance of push-in connectors for use with thermoplastic tubes with outside diameters of 3 mm to 12 mm, inclusive.

This International Standard is intended to establish uniform methods of testing complete push-in connector assemblies as used in pneumatic fluid power applications. It is not applicable to air braking systems.

NOTE In road vehicles, it is necessary to exercise special care to ensure that these connectors are never used in an air braking system.

2 Normative references

The following referenced documents are indispensable for the application of this document. For dated references, only the edition cited applies. For undated references, the latest edition of the referenced document (including any amendments) applies.

ISO 1746 ¹⁾, *Rubber or plastics hoses and tubing — Bending tests*

ISO 4759-1:2000, *Tolerances for fasteners — Part 1: Bolts, screws, studs and nuts — Product grades A, B and C*

ISO 5598, *Fluid power systems and components — Vocabulary*

ISO 8573-1, *Compressed air — Part 1: Contaminants and purity classes*

ISO 16030, *Pneumatic fluid power — Connections — Ports and stud ends*

3 Terms and definitions

For the purposes of this document, the terms and definitions given in ISO 5598 apply.

4 Performance requirements

4.1 Material

4.1.1 Connectors shall be made from materials that will fulfil the performance requirements.

4.1.2 In order to ensure proper grip, the locking mechanism, tube end of reducers and plugs shall be made from suitable thermoplastics.

1) To be published. (Revision of ISO 1746:1998)

4.2 Pressure and temperature

4.2.1 Push-in connectors shall provide connections from $-0,09 \text{ MPa}$ [$-0,9 \text{ bar}^2$] to a working pressure of $1,6 \text{ MPa}$ (16 bar) when used at temperatures between $-20 \text{ }^\circ\text{C}$ and $+80 \text{ }^\circ\text{C}$.

4.2.2 The connector assembly shall meet the performance requirements given in Clause 9.

4.2.3 The connectors shall be capable of meeting or exceeding the combination of the highest pressure and temperature of the tubes specified in Annex A. When tubing with a lower rated pressure is used, the maximum working pressure of the tube and connector assembly shall be that of the tubing.

5 Features

Design is at the choice of the manufacturer. Two examples are shown in Figure 1.

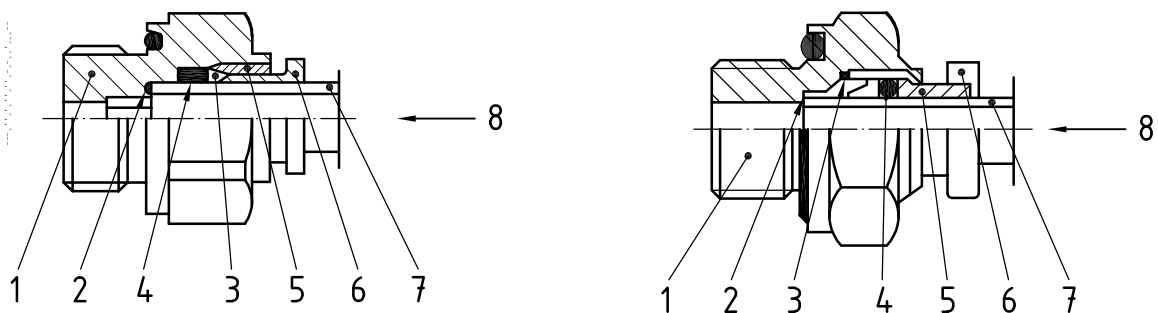

a) With sealing system located beyond the locking mechanism

b) With sealing system located in front of the locking mechanism

Key

- | | |
|---------------------|-------------------------------|
| 1 body | 5 releasing sleeve |
| 2 tube stop | 6 removable button (optional) |
| 3 grab ring of tube | 7 tube |
| 4 sealing of tube | 8 entry of the tube |

Figure 1 — Examples of design and description of the features of push-in connectors for use with thermoplastic tubes

6 Outside diameter of tube

The outside diameter of the tube shall be chosen from the following range of sizes:

- 3 mm, 4 mm, 6 mm, 8 mm, 10 mm and 12 mm.

2) $1 \text{ bar} = 0,1 \text{ MPa} = 10^5 \text{ Pa}$; $1 \text{ MPa} = 1 \text{ N/mm}^2$

7 Design

7.1 Push-in connector dimensions shown in Figures 2 to 7 shall conform to the dimensions given in Tables 1 to 4.

7.2 Hexagon tolerances across flats shall be in accordance with ISO 4759-1:2000, Grade C. The minimum hexagon across-corner turn diameter of 1,092 times the normal across flats dimension shall be used.

7.3 Details of contour shall be at the option of the manufacturer, as long as the dimensions given in the tables are maintained.

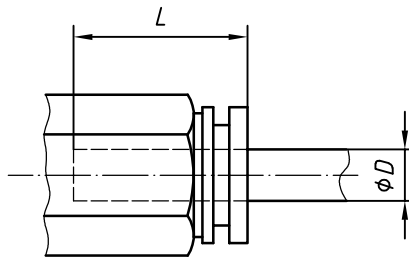

Figure 2 — Tube insertion depth

Table 1 — Maximum tube insertion depth

Dimensions in millimetres

Tube OD D	Insertion depth L max.
3	16
4	18
6	19
8	20
10	24
12	25

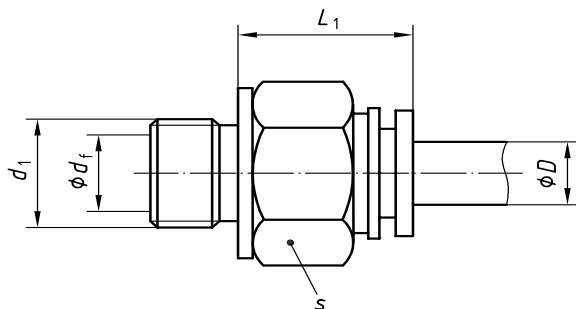

Figure 3 — Stud adaptor (SDS)

Table 2 — Dimensions for stud adaptors (SDS)

Dimensions in millimetres

Tube OD <i>D</i>	<i>d</i> ₁ ^a	<i>L</i> ₁ max.	<i>s</i> ^b max.	Flow diameter <i>d</i> _f min.
3	M3	10	8	1,2
	M5	17	10	1,8
4	M5	22	12	2
	M7	22	12	2,5
6	M7	23	14	4
	G 1/8	23	14	4
8	G 1/8	24	17	5,5
	G 1/4	24	19	6
10	G 1/4	27	19	7,5
	G 3/8	27	22	8
12	G 3/8	30	22	10
	G 1/2	30	26	10

^a Thread and stud end in accordance with ISO 16030.
^b Hexagon socket or outside diameter at the choice of the manufacturer.

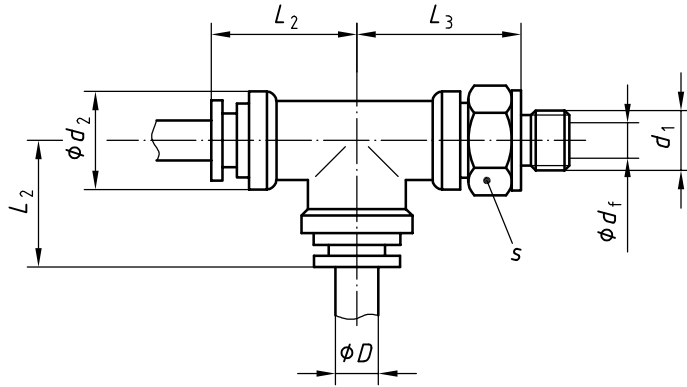

Figure 4 — Swivel male run tee (SWRT)

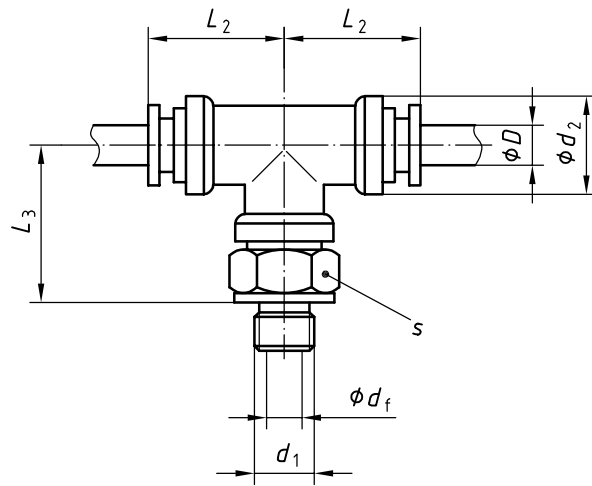

Figure 5 — Swivel male branch tee (SWBT)

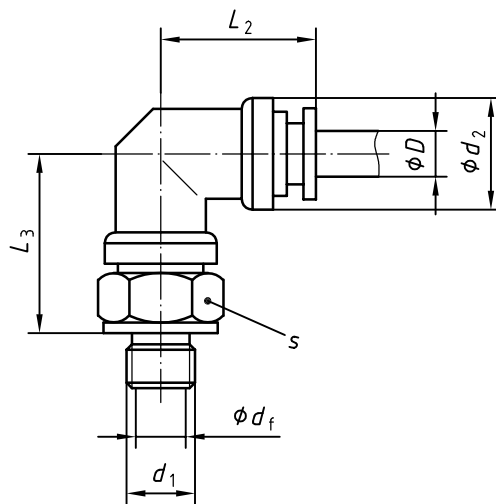

Figure 6 — Swivel male elbow (SWE)

Table 3 — Dimensions for swivel male run tees (SWRT), swivel male branch tees (SWBT) and swivel male elbows (SWE)

Dimensions in millimetres

Tube OD <i>D</i>	<i>d</i> ₁ ^a	<i>d</i> ₂ max.	<i>L</i> ₂ max.	<i>L</i> ₃ max.	<i>s</i> ^b max.	Flow diameter <i>d</i> _f min.
3	M3	10	19	16	6	1,2
	M5	10	19	18	10	1,8
4	M5	13	21	21	10	2
	M7	13	21	21	12	2,5
6	M7	15	23	26	14	4
	G 1/8	15	23	26	14	4
8	G 1/8	17	26	28	14	5,5
	G 1/4	17	26	28	19	6
10	G 1/4	22	29	32	19	7,5
	G 3/8	22	29	32	22	8
12	G 3/8	24	32	37	22	10
	G 1/2	24	32	37	26	10

^a Thread and stud end in accordance with ISO 16030.
^b Hexagon socket or outside diameter at the choice of the manufacturer.

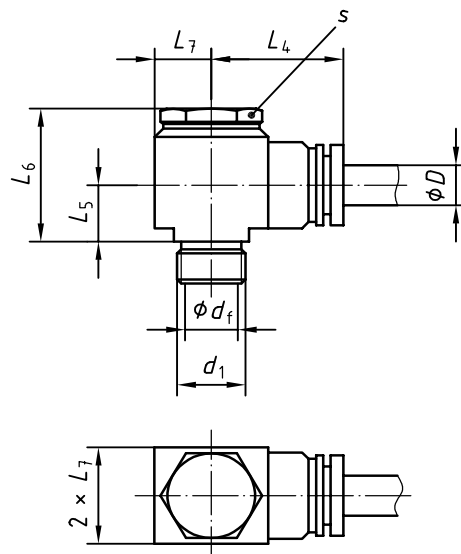

Figure 7 — Male banjo elbow (BJE) connectors

Table 4 — Dimensions for male banjo elbow (BJE) connectors

Dimensions in millimetres

Tube OD <i>D</i>	<i>d</i> ₁ ^a	<i>L</i> ₄ max.	<i>L</i> ₅ max.	<i>L</i> ₆ max.	<i>L</i> ₇ max.	<i>s</i> max.	Flow diameter <i>d</i> _f min.
3	M3	20	10	22	5	6	1,2
	M5	20	10	25	8	10	1,8
4	M5	24	10	25	8	10	2
	M7	24	12	26	9	12	2,5
6	M7	24	12	26	9	14	4
	G 1/8	24	12	26	9	14	4
8	G 1/8	26	14	29	11	14	5,5
	G 1/4	32	14	32	11	19	6
10	G 1/4	39	14	34	13	22	7,5
	G 3/8	39	16	39	13	22	8
12	G 3/8	44	16	39	15	22	10
	G 1/2	44	16	42	17	26	10

^a Thread and stud end in accordance with ISO 16030.

8 Marking

Each push-in connector shall be permanently marked with the manufacturer's/supplier's name or trademark and with the outside diameter of the tube with which it is to be used.

9 Performance requirements and testing

9.1 General

9.1.1 This clause establishes minimum qualification requirements for tensile load, pressure capabilities, leakage, connection forces, disconnection forces and cyclic endurance (impulse) for pneumatic push-in connectors for use with thermoplastic tubes.

9.1.2 Unless otherwise specified, tests shall be conducted at room temperature ($23\text{ °C} \pm 5\text{ °C}$) and a relative humidity level of $65\% \pm 5\%$.

9.1.3 Unless otherwise specified, a tolerance of $\pm 5\%$ applies to all test characteristics.

9.2 Test samples

9.2.1 Three test samples shall be subjected to the proof and burst pressure tests; six test samples shall be subjected to all other tests.

9.2.2 Prior to testing, polyamide tubing shall be conditioned at a relative humidity level of $65\% \pm 5\%$ and at an ambient temperature of $23\text{ °C} \pm 5\text{ °C}$ for a minimum of 14 days (336 h).

9.2.3 Test samples shall consist of a push-in connector connected to the test tubing defined in Annexes A and B. Except for the tests specified in 9.6 and 9.7, the tubes for the test samples shall be cut to provide a length that is 20 times the outside diameter of the tube between the two ends of the connectors when connected. The tubes shall be connected in accordance with the connector manufacturer's specification.

9.2.4 Prior to testing, each connector to be tested shall be connected and disconnected four times and then connected a fifth time so that testing can be conducted.

9.3 Tensile test

9.3.1 Procedure

9.3.1.1 The test shall be conducted under unpressurized conditions.

9.3.1.2 The test sample shall be placed in a tensile machine and fixture so that the samples and end fixtures are co-linear. One end of the test sample shall be stationary, and the opposite end shall be attached to the moving member of the test apparatus. A tensile load shall be applied at a rate of 1 mm/s along the axis of the test specimen.

9.3.2 Pass/fail criteria

The test sample shall withstand the minimum tensile load shown in Table 5 without separation from the connector.

Table 5 — Minimum tensile load for tensile test

Tube OD, <i>D</i> , mm	3	4	6	8	10	12
Minimum tensile load for polyamide (PA) tube, N	60	70	120	170	250	300
Minimum tensile load for polyurethane (PU) tube, N	25	50	100	150	200	200

9.4 Proof and burst pressure test (for polyamide tubing only)

9.4.1 Description

The proof and burst pressure test is conducted with polyamide tubing, as specified in Annex A, and is intended to evaluate the ability of the connector to retain the tubing at a proof pressure of 1,5 times the rated pressure and at a minimum burst pressure of three times the rated pressure.

9.4.2 Apparatus

The test apparatus shall consist of a suitable source of pressure and the necessary gauges and piping. The test fluid shall be water.

9.4.3 Procedure

9.4.3.1 Plug one end of the test specimen and mount it in the apparatus with the plugged end unrestrained. Apply a proof pressure of 1,5 times the rated pressure to the test specimen and hold for a minimum of 30 s.

9.4.3.2 Increase pressure at a constant rate of 0,1 MPa/s to 0,2 MPa/s (1 bar/s to 2 bar/s) so as to reach the specified minimum burst pressure, i.e. three times the rated pressure. See Figure 8 for a typical pressure trace for the proof and burst pressure test.

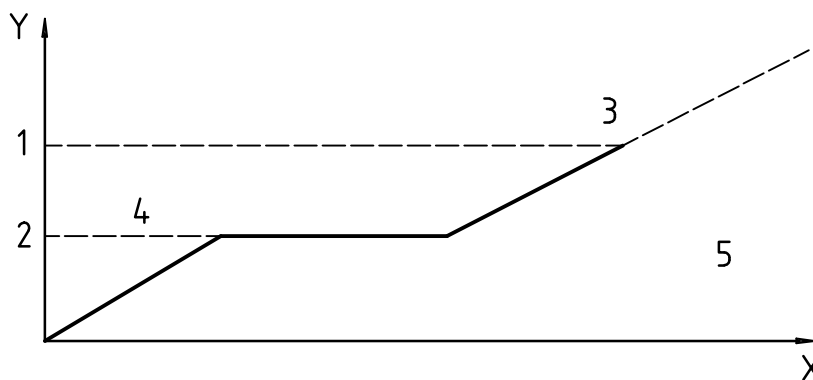
**Key**

X time

Y pressure

1 3 times the rated pressure

2 1,5 times the rated pressure

3 burst pressure

4 proof pressure

5 0,1 MPa/s to 0,2 MPa/s

Figure 8 — Typical pressure trace for proof and burst pressure test**9.4.4 Pass/fail criteria**

9.4.4.1 The connection under test shall not exhibit any visual deformation or visual evidence of leakage after being subjected to the proof pressure for a minimum of 30 s.

9.4.4.2 The connection under test shall not fail after being subjected to the minimum burst pressure.

9.5 Connecting force test**9.5.1 Apparatus**

Use an appropriate compression machine and suitable gauge to measure forces.

9.5.2 Procedure

Mount the threaded end of the connector into a stationary fixture. Insert the tube into the connector by applying a compression load with the compression test machine set at a rate of 1 mm/s, and measure and record the maximum connecting force.

9.5.3 Pass/fail criteria

The force needed to connect shall not exceed the value given in Table 6 for the relevant tube outside diameter.

Table 6 — Maximum connecting and disconnecting forces

Tube OD, D , mm	3	4	6	8	10	12
Maximum connecting force, N	35	45	60	80	100	130
Maximum disconnecting force, N	30	40	50	60	70	80

9.6 Disconnecting force test

9.6.1 Apparatus

Use an appropriate tensile test machine and suitable gauge to measure forces.

9.6.2 Procedure

Apply a permanent load on the connector's releasing mechanism according to the manufacturer's recommendation. Apply a tensile load with the tensile test machine set at a rate of 1 mm/s, and measure and record the maximum disconnecting force.

9.6.3 Pass/fail criteria

The force needed to disconnect shall not exceed the value given in Table 6 for the relevant tube outside diameter.

9.7 Leakage test (to be performed before disconnecting)

9.7.1 Description

This test is intended to evaluate leakage after a test sample has been subjected to various temperatures and pressures.

9.7.2 Apparatus

9.7.2.1 The tube and connector shall be installed as shown in Figure 9 in a temperature cabinet capable of controlling the temperature within the ranges specified in Figures 10 and 11.

9.7.2.2 The radius of the bend in the tubing shall be in accordance with Table A.1 for polyamide tubing and Table B.1 for polyurethane tubing.

9.7.2.3 The length of the tube, l , shall be calculated from the following formula:

$$l = 2L_{\text{real}} + \pi (R + 0,5D)$$

where

L_{real} is the actual insertion depth of the test sample, in millimetres (see Figure 2 for an illustration of this dimension);

R is the minimum bending radius from Table A.1 or Table B.1, in millimetres;

D is the outside diameter of the tubing, in millimetres.

9.7.2.4 The distance between the ports, A , shall be calculated from the following formula:

$$A = 2R + D$$

where

R is the minimum bending radius from Table A.1 or Table B.1, in millimetres;

D is the outside diameter of the tubing, in millimetres.

9.7.2.5 A mass flowmeter of a range of less than 5 cm³/min shall be used to measure the leakage rate at each of the four leakage measurement sites indicated in Figure 9.

9.7.2.6 Compressed air of purity classes ISO 8573-1 3 – – shall be used.

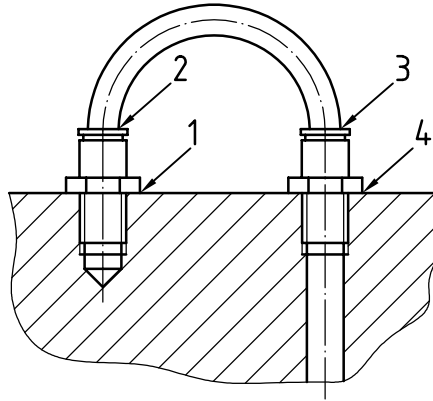

Key

1 to 4 leakage measurement sites

Figure 9 — Test assembly for leakage test and locations of leakage measurement sites

9.7.3 Procedure

9.7.3.1 Subject the test sample to the temperature cycle defined in Figure 10 (for polyamide tubing) and Figure 11 (for polyurethane tubing), within a tolerance of ± 2 °C. The rate of temperature increase and decrease is at the option of the person performing the test, as long as the requirements of Figures 10 and 11 are met.

9.7.3.2 When each point labelled P_1 is reached, apply pressure at 0,1 MPa (1 bar), 0,6 MPa (6 bar) and – 0,09 MPa (– 0,9 bar), then measure and record the leakage rate at each pressure level for all of the leakage measurement sites indicated in Figure 9.

9.7.3.3 When the point labelled P_2 is reached, apply pressure at 0,1 MPa (1 bar) and 0,6 MPa (6 bar), then measure and record the leakage rate at each pressure level for all of the leakage measurement sites indicated in Figure 9.

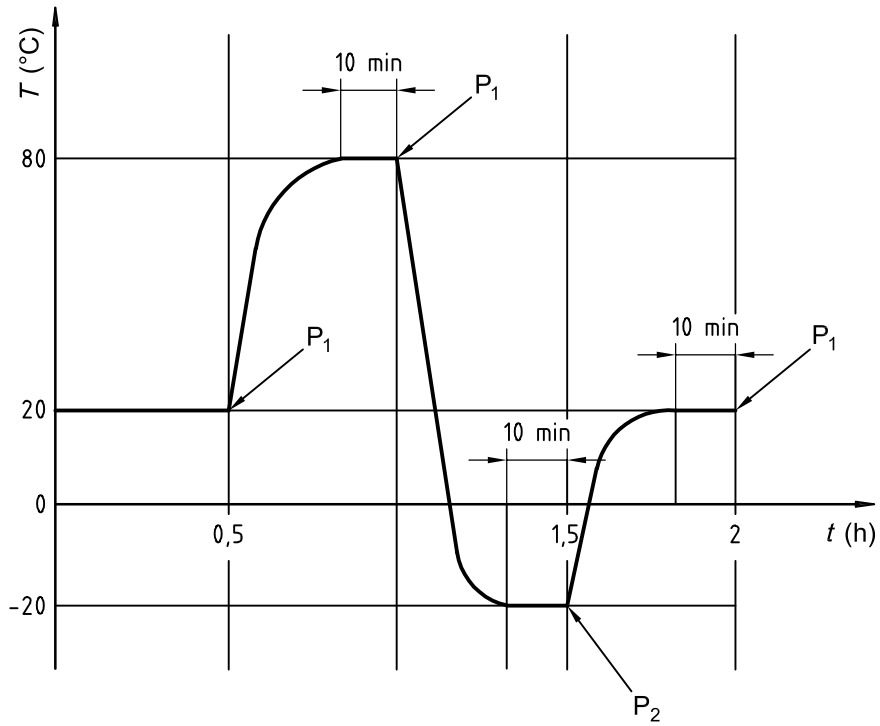

Figure 10 — Temperature cycle trace for polyamide tubing

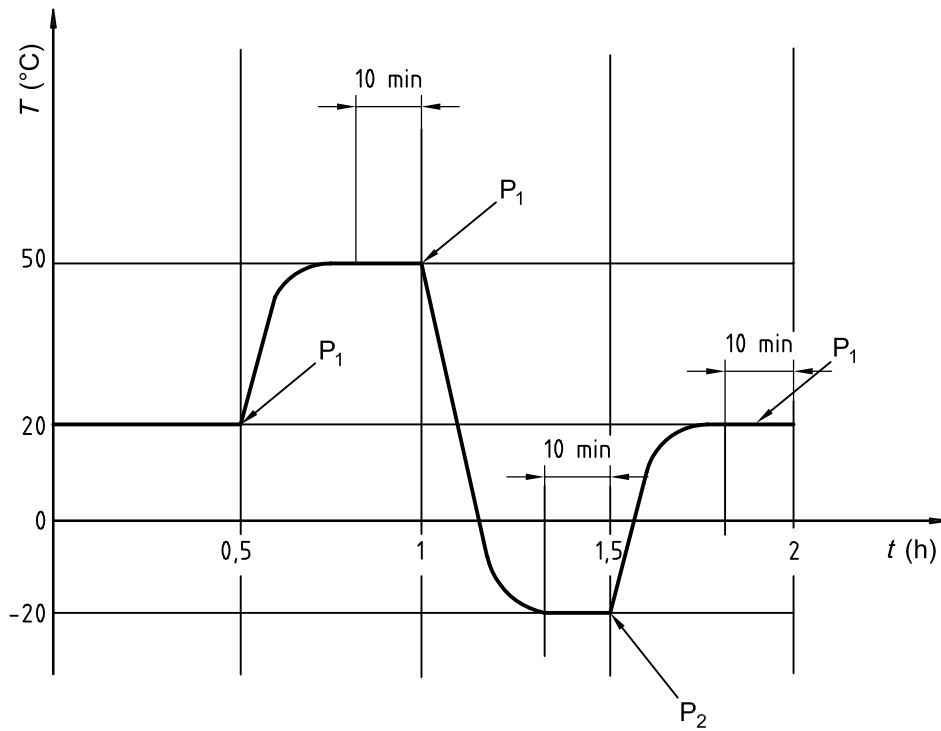

Figure 11 — Temperature cycle trace for polyurethane tubing

9.7.4 Pass/fail criteria

The leakage rate at the various temperature and pressure levels shall not exceed the maximum allowable leakage rate values given in Table 7.

Table 7 — Maximum allowable leakage rate

Temperature, °C, ± 2 °C	Polyamide tubing	– 20	+ 20	+ 80
	Polyurethane tubing	– 20	+ 20	+ 50
Maximum allowable leakage rate, cm ³ /min	at 0,1 MPa (1 bar) and 0,6 MPa (6 bar)	2	1	1
	at – 0,09 MPa (– 0,9 bar)	—	1	—

9.8 Cyclic endurance (impulse) test with vibration (for polyamide tubing only)

9.8.1 Description

This test is intended to evaluate the endurance of a tube and connector assembly under vibration and pressure pulsating conditions. This test applies only to polyamide tubing.

9.8.2 Apparatus

9.8.2.1 Equipment capable of vibrating one end of the test sample in accordance with the requirements of 9.8.3.2 and Figures 12 and 13 shall be provided.

9.8.2.2 A mass flowmeter to measure the leakage rate shall be provided.

9.8.3 Procedure

9.8.3.1 Mount one end of the test assembly on the static support and the other end on the vibration head, making sure that the tubing is bent at the minimum bending radius specified in Annex A with a tolerance of ${}_{-10}^{0}$ %. The length of the tubing sample shall ensure that the tubing is not bent to a radius smaller than the minimum bending radius specified in Annex A during displacement.

9.8.3.2 Using dry air, pressurize the test sample at 0 MPa (0 bar) and 0,6 MPa (6 bar) in accordance with the pressure cycle shown in Figure 12. Subject the test sample to vibration with a constant displacement of 20 mm peak-to-peak at a frequency from 5 Hz to 18 Hz (see Figure 13), then to a constant acceleration of 117,7 m/s² at a frequency up to 500 Hz with a sweep rate of 1 octave/min. Each test sample shall be subjected to vibration for 8 h in each direction (X, Y and Z axes).

9.8.3.3 For each measurement of the leakage rate, stabilize the pressure at 0,6 MPa (6 bar) for 1 min to take the first leakage rate measurement, then stabilize the pressure at 0,1 MPa (1 bar) for 1 min to take the second measurement, and then complete the cycle until the next measurement points are reached. Each measurement shall be taken during the last 10 s of the pressure-stabilization interval and during the mechanical vibration cycle.

9.8.4 Pass/fail criteria

The total leakage rate for all six test samples, at room temperature, shall not exceed 3 cm³/min.

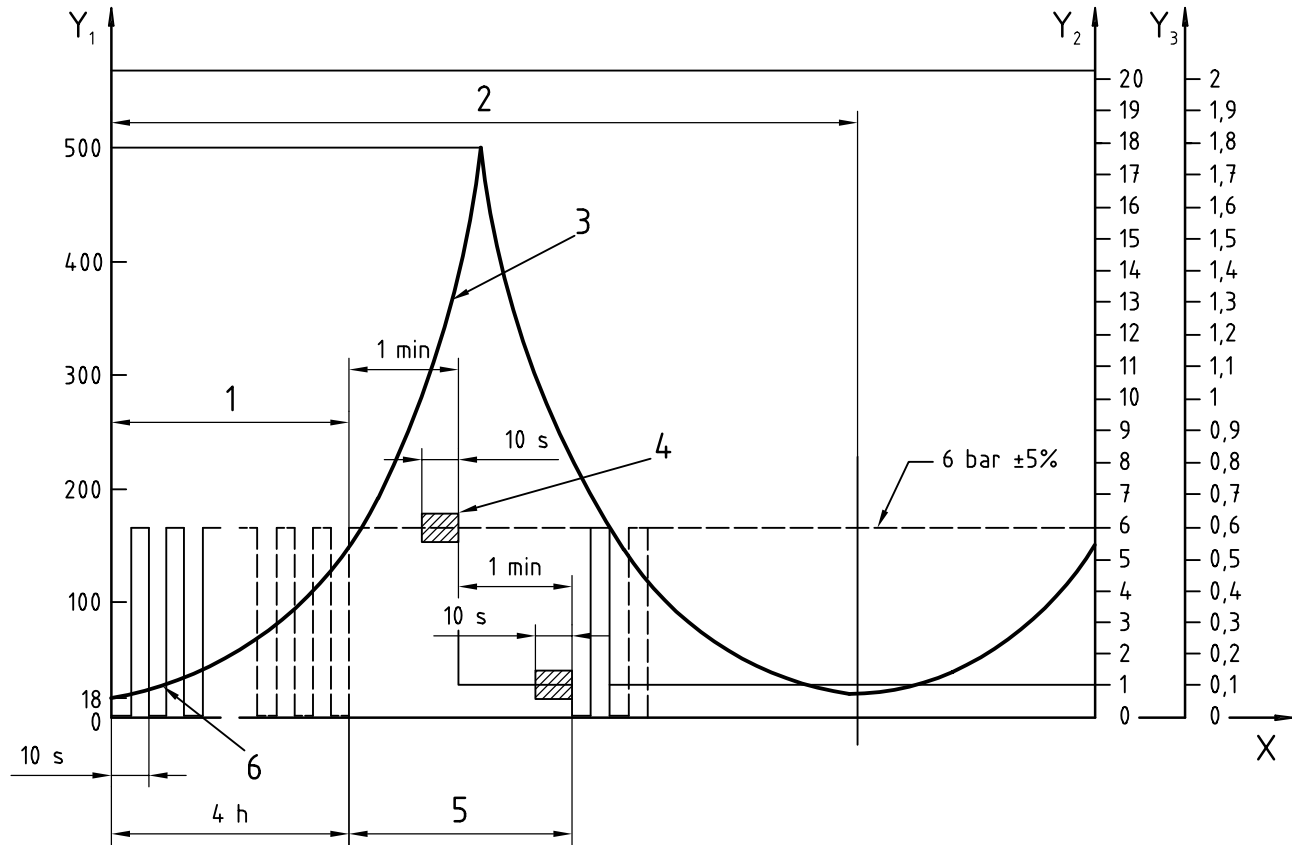

Key

X time, s

Y₁ frequency, Hz

Y₂ pressure, bar

Y₃ pressure, MPa

1 pressure cycle

2 one complete vibration cycle

3 constant acceleration of 117,7 m/s² at a frequency from 18 Hz to 500 Hz, with a sweep rate of 1 octave per minute

4 measurement frame

5 general tolerance for leakage rate measurement ± 5 %

6 constant displacement 20 mm peak-to-peak at a frequency from 5 Hz to 18 Hz

Figure 12 — Vibration profile and pressure cycle for the cyclic endurance (impulse) test with vibration

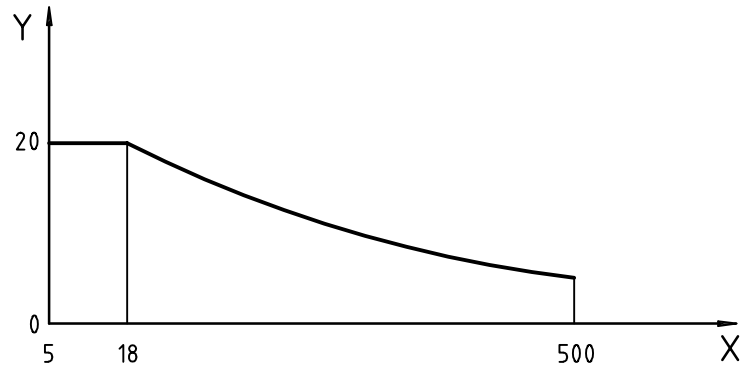

NOTE Because of the frequency and the constant acceleration, the peak-to-peak displacement cannot exceed 20 mm for a frequency higher than 18 Hz.

Key

X frequency, Hz

Y peak-to-peak displacement, mm

Figure 13 — Peak-to-peak displacement vs. frequency

10 Designation

10.1 Connectors shall be designated by an alphanumeric code to facilitate ordering. They shall be designated by ISO 14743 followed by a space, then the connector style letter symbol (see 10.2), followed by a space, and for the ends, the outside diameter of the tube with which they are to be connected, each separated by a small \times . For the threaded ends, the thread designation shall be included in the code.

10.2 The letter symbol designation of the connector shall have two parts: the connection end type immediately followed by the shape of the connector. The following letter symbols shall be used:

Connector end type	Symbol
Swivel	SW
Banjo	BJ
Bulkhead	BH
Plug	PL
Port	P
Stud	SD
Tube end	TE

Shape	Symbol
Straight	S
Elbow	E
Tee	T
Run tee	RT
Branch tee	BT
Cross	K
Y	Y

10.3 Stud connectors and port connectors shall be designated by specifying the tube to be connected first, then the thread size for the stud or port end.

10.4 Tube ends shall be designated by specifying the tube to be connected first, then the tube end size.



10.5 Table 8 gives examples of designations.

11 Identification statement (reference to this International Standard)

Use the following statement in test reports, catalogues and sales literature when electing to comply with this International Standard:

“Pneumatic push-in connectors in accordance with ISO 14743:2004, *Pneumatic fluid power — Push-in connectors for thermoplastic tubes.*”

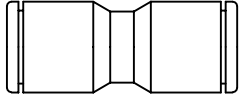
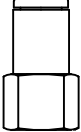
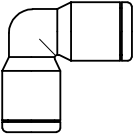
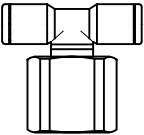
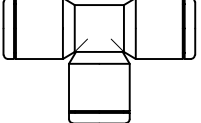
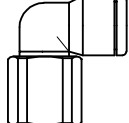
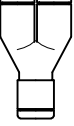
Table 8 — Examples of designation

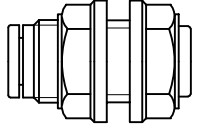
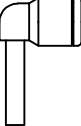
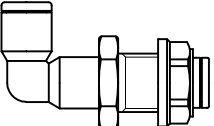
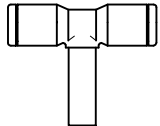
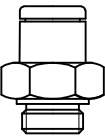
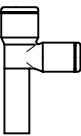
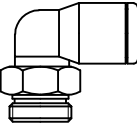
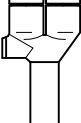
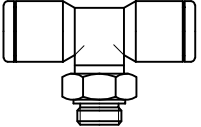
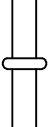
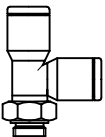
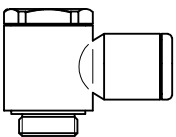
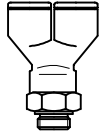
	ISO 14743 S 6 ISO 14743 S 6 × 4		ISO 14743 PS 6 × G 1/8
	ISO 14743 E 6		ISO 14743 SWPBT 6 × G 1/8
	ISO 14743 T 6		ISO 14743 SWPE 6 × G 1/8
	ISO 14743 Y 6 ISO 14743 Y 6 × 4		ISO 14743 TES 6 × 4
	ISO 14743 BHS 6		ISO 14743 TEE 6
	ISO 14743 SWBHE 6		ISO 14743 TEBT 6
	ISO 14743 SDS 6 × G 1/8		ISO 14743 TERT 6
	ISO 14743 SWE 6 × M7		ISO 14743 TEY 6
	ISO 14743 SWBT 6 × M7		ISO 14743 TE 6
	ISO 14743 SWRT 6 × M7		ISO 14743 BJE 6 × G 1/8
	ISO 14743 SWY 6 × M7		

Annex A (normative)

Polyamide tubes for testing

A.1 Scope

This annex defines the dimensions, tolerances, rated pressures and test method for determining the rated pressure of polyamide 11 and 12 tubes used for testing pneumatic push-in connectors defined in this International Standard.

This annex is applicable to tubes with outside diameters between 3 mm and 12 mm, inclusive. The rated pressures of the tubes vary according to the temperatures at which they are to be used, which range from -20 °C to $+80\text{ °C}$.

NOTE The mechanical characteristics of polyamide tubes allow a connector to be anchored on the outside of the tubing wall; the outside diameters defined in this annex, except for the diameter 3 mm, have been chosen from the range of outside diameters of rigid tubes given in ISO 4397.

A.2 Material requirements

The material shall be homogeneous, and the tubes shall not present any defects in appearance. Tubes intended for general use are manufactured from plasticized polyamide. Normalized material, heat- and light-stabilized (93 ± 3) Shore A, is recommended.

A.3 Dimensions and tolerances

Dimensions of tubes shall be in accordance with Table A.1. Each dimension shall be measured at its minimum and maximum in the same cross-section. Both of these measured values shall fall within the tube outside diameter tolerance given in Table A.1.

Table A.1 — Dimensions and tolerances for polyamide tubes for testing

Dimensions in millimetres

Tube outside diameter <i>D</i>		Wall thickness <i>e</i>		Tube inside diameter <i>d</i>	Minimum bending radius at 23 °C ^a
nom.	tol.	nom.	tol.	ref.	
3	$\pm 0,08$	0,6	$\pm 0,08$	1,8	15
4	$\pm 0,08$	0,75	$\pm 0,08$	2,5	20
6	$\pm 0,08$	1	$\pm 0,08$	4	35
8	$\pm 0,08$	1	$\pm 0,08$	6	55
10	$\pm 0,08$	1,25	$\pm 0,08$	7,5	75
12	$\pm 0,1$	1,5	$\pm 0,08$	9	75

NOTE Ovality is included in general tolerances.

^a The method of determining the bending radius shall be in accordance with ISO 1746.

A.4 Test method to determine rated pressure

A.4.1 Description

In this test, five test samples of each outside diameter size at least 300 mm each in length are subjected to an increasing internal pressure until burst.

A.4.2 Procedure

A.4.2.1 The test shall be conducted at an ambient temperature of $(23 \pm 2) ^\circ\text{C}$ and test fluid temperatures of $(23 \pm 2) ^\circ\text{C}$ and $(80 \pm 2) ^\circ\text{C}$.

A.4.2.2 Test samples shall be purged of air before pressure is applied.

A.4.2.3 Apply hydrostatic pressure by means of a hydraulic pump or accumulator system with a calibrated pressure gauge graduated in megapascals or bars, increase the pressure at a constant rate of 0,1 MPa/s to 0,2 MPa/s (1 bar/s to 2 bar/s) until burst occurs. Record the maximum pressure reached during the test as the burst pressure.

A.4.3 Determination of rated pressure

The tubing shall be rated at the relevant rated pressure in Table A.2 if the burst pressure of each of the five test samples exceeds the relevant minimum burst pressure given in Table A.2.

Table A.2 — Rated pressures and minimum burst pressures for polyamide tubes

Tube outside diameter <i>D</i> mm	Rated pressure MPa (bar)				Minimum burst pressure MPa (bar)	
	from $-20 ^\circ\text{C}$ to $+20 ^\circ\text{C}$	from $+20 ^\circ\text{C}$ to $+30 ^\circ\text{C}$	from $+30 ^\circ\text{C}$ to $+50 ^\circ\text{C}$	from $+50 ^\circ\text{C}$ to $+80 ^\circ\text{C}$	at $23 ^\circ\text{C}$	at $80 ^\circ\text{C}$
3	1,75 (17,5)	1,45 (14,5)	1,1 (11)	0,9 (9)	8,1 (81)	2,6 (26)
4	2,6 (26)	2,1 (21)	1,5 (15)	0,8 (8)	7,9 (79)	2,5 (25)
6	2,4 (24)	2,0 (20)	1,5 (15)	0,8 (8)	7,1 (71)	2,3 (23)
8	1,7 (17)	1,4 (14)	1,1 (11)	0,5 (5)	5,1 (51)	1,6 (16)
10	1,7 (17)	1,4 (14)	1,1 (11)	0,6 (6)	5,3 (53)	1,7 (17)
12	1,8 (18)	1,45 (14,5)	1,1 (11)	0,6 (6)	5,3 (53)	1,7 (17)

Annex B (normative)

Polyurethane tubes for testing

B.1 Scope

This annex defines the dimensions, tolerances, rated pressures and test method for determining the rated pressure of polyurethane tubes used for testing pneumatic push-in connectors defined in this International Standard.

This annex is applicable to tubes with outside diameters between 3 mm and 12 mm, inclusive. The rated pressures of the tubes vary according to the temperatures at which they are to be used, which range from -20 °C to $\pm 50\text{ °C}$.

NOTE The mechanical characteristics of polyurethane tubes allow a connector to be anchored on the outside of the tubing wall; the outside diameters defined in this annex, except for the diameter 3 mm, have been chosen from the range of outside diameters of rigid tubes given in ISO 4397.

B.2 Material requirements

The material shall be homogeneous, and the tubes shall not present any defects in appearance. Normalized material, heat- and light-stabilized (63 ± 2) Shore D, is recommended.

B.3 Dimensions and tolerances

Dimensions of tubes shall be in accordance with Table B.1. Each dimension shall be measured at its minimum and maximum in the same cross-section. Both of these measured values shall fall within the tube outside diameter tolerance given in Table B.1.

Table B.1 — Dimensions and tolerances for polyurethane tubes for testing

Dimensions in millimetres

Tube outside diameter <i>D</i>		Wall thickness <i>e</i>		Tube inside diameter <i>d</i>	Minimum bending radius at 23 °C ^a
nom.	tol.	nom.	tol.	ref.	
3	$\pm 0,1$	0,6	$+ 0,10$ $- 0,05$	1,8	10
4	$\pm 0,1$	0,75	$+ 0,10$ $- 0,05$	2,5	12
6	$\pm 0,1$	1	$+ 0,10$ $- 0,05$	4	15
8	$\pm 0,1$	1,25	$+ 0,10$ $- 0,05$	5,5	20
10	$\pm 0,15$	1,5	$+ 0,15$ $- 0,07$	7	25
12	$\pm 0,15$	2	$+ 0,15$ $- 0,07$	8	35

NOTE Ovality is included in general tolerances.

^a The method of determining the bending radius shall be in accordance with ISO 1746.

B.4 Test method to determine rated pressure

B.4.1 Description

In this test, five test samples of each outside diameter size at least 300 mm each in length are subjected to an increasing internal pressure until burst.

B.4.2 Procedure

B.4.2.1 The test shall be conducted at an ambient temperature of $(23 \pm 2) ^\circ\text{C}$ and test fluid temperatures of $(23 \pm 2) ^\circ\text{C}$ and $(50 \pm 2) ^\circ\text{C}$.

B.4.2.2 Test samples shall be purged of air before pressure is applied.

B.4.2.3 Apply hydrostatic pressure by means of a hydraulic pump or accumulator system with a calibrated pressure gauge graduated in megapascals or bars, and increase the pressure at a constant rate of 0,1 MPa/s to 0,2 MPa/s (1 bar/s to 2 bar/s) until burst occurs. Record the maximum pressure reached during the test as the burst pressure.

B.4.3 Determination of rated pressure

The tubing shall be rated at the relevant rated pressure in Table B.2 if the burst pressure of each of the five test samples exceeds the relevant minimum burst pressure given in Table B.2.

Table B.2 — Rated pressures and minimum burst pressures for polyurethane tubes

Tube outside diameter <i>D</i> mm	Rated pressure MPa (bar)		Minimum burst pressure MPa (bar)	
	from $-25 ^\circ\text{C}$ to $+25 ^\circ\text{C}$	from $+25 ^\circ\text{C}$ to $+50 ^\circ\text{C}$	at $23 ^\circ\text{C}$	at $50 ^\circ\text{C}$
3	1,0 (10)	0,65 (6,5)	3 (30)	1,9 (19)
4	1,0 (10)	0,65 (6,5)	3 (30)	1,9 (19)
6	0,85 (8,5)	0,55 (5,5)	2,55 (25,5)	1,6 (16)
8	0,85 (8,5)	0,55 (5,5)	2,55 (25,5)	1,6 (16)
10	0,85 (8,5)	0,55 (5,5)	2,55 (25,5)	1,6 (16)
12	0,85 (8,5)	0,55 (5,5)	2,55 (25,5)	1,6 (16)

Bibliography

- [1] ISO 228-1:2000, *Pipe threads where pressure-tight joints are not made on the threads — Part 1: Dimensions, tolerances and designation*
- [2] ISO 4397, *Fluid power systems and components — Connectors and associated components — Nominal outside diameters of tubes and nominal inside diameters of hoses*
- [3] ISO 6358:1989, *Pneumatic fluid power — Components using compressible fluids — Determination of flow-rate characteristics*

ICS 23.100.40

Price based on 22 pages