

---

---

**Rolling bearings — Linear motion  
rolling bearings —**

**Part 1:  
Dynamic load ratings and rating life**

*Roulements — Roulements à mouvement linéaire —*

*Partie 1: Charges dynamiques de base et durée nominale*





**COPYRIGHT PROTECTED DOCUMENT**

© ISO 2017, Published in Switzerland

All rights reserved. Unless otherwise specified, no part of this publication may be reproduced or utilized otherwise in any form or by any means, electronic or mechanical, including photocopying, or posting on the internet or an intranet, without prior written permission. Permission can be requested from either ISO at the address below or ISO's member body in the country of the requester.

ISO copyright office  
Ch. de Blandonnet 8 • CP 401  
CH-1214 Vernier, Geneva, Switzerland  
Tel. +41 22 749 01 11  
Fax +41 22 749 09 47  
copyright@iso.org  
www.iso.org

# Contents

	Page
<b>Foreword</b> .....	<b>iv</b>
<b>Introduction</b> .....	<b>v</b>
<b>1 Scope</b> .....	<b>1</b>
<b>2 Normative references</b> .....	<b>1</b>
<b>3 Terms and definitions</b> .....	<b>1</b>
<b>4 Symbols</b> .....	<b>7</b>
<b>5 Basic dynamic load ratings</b> .....	<b>8</b>
5.1 Linear ball bearings .....	8
5.1.1 Recirculating linear ball bearings, sleeve type with raceway grooves .....	8
5.1.2 Recirculating linear ball bearings, sleeve type without raceway grooves .....	9
5.1.3 Recirculating linear ball bearings, linear guideway, carriage type .....	9
5.1.4 Non-recirculating linear ball bearings, linear guideway, deep groove and four-point-contact types .....	10
5.2 Linear roller bearings .....	11
5.2.1 Recirculating linear roller bearings, linear guideway, carriage type .....	11
5.2.2 Non-recirculating linear roller bearings, linear guideway, flat, V-angle and crossed roller types .....	11
<b>6 Dynamic equivalent load</b> .....	<b>12</b>
<b>7 Basic rating life</b> .....	<b>12</b>
<b>Bibliography</b> .....	<b>14</b>

## Foreword

ISO (the International Organization for Standardization) is a worldwide federation of national standards bodies (ISO member bodies). The work of preparing International Standards is normally carried out through ISO technical committees. Each member body interested in a subject for which a technical committee has been established has the right to be represented on that committee. International organizations, governmental and non-governmental, in liaison with ISO, also take part in the work. ISO collaborates closely with the International Electrotechnical Commission (IEC) on all matters of electrotechnical standardization.

The procedures used to develop this document and those intended for its further maintenance are described in the ISO/IEC Directives, Part 1. In particular the different approval criteria needed for the different types of ISO documents should be noted. This document was drafted in accordance with the editorial rules of the ISO/IEC Directives, Part 2 (see [www.iso.org/directives](http://www.iso.org/directives)).

Attention is drawn to the possibility that some of the elements of this document may be the subject of patent rights. ISO shall not be held responsible for identifying any or all such patent rights. Details of any patent rights identified during the development of the document will be in the Introduction and/or on the ISO list of patent declarations received (see [www.iso.org/patents](http://www.iso.org/patents)).

Any trade name used in this document is information given for the convenience of users and does not constitute an endorsement.

For an explanation on the meaning of ISO specific terms and expressions related to conformity assessment, as well as information about ISO's adherence to the World Trade Organization (WTO) principles in the Technical Barriers to Trade (TBT) see the following URL: [www.iso.org/iso/foreword.html](http://www.iso.org/iso/foreword.html)

This document was prepared by Technical Committee ISO/TC 4, *Rolling bearings*, Subcommittee SC 8, *Load ratings and life*.

This second edition cancels and replaces the first edition (ISO 14728-1:2004), of which it constitutes a minor revision with the following changes:

- improvement of [Figures 2, 4, 8](#) and [9](#);
- correction of terms and definitions (change of ball/roller guide systems to linear ball/roller bearings);
- correction of font ( $\phi$  changed to  $\varphi$ );
- alignment with the latest drafting rules.

A list of parts in the ISO 14728 series can be found on the ISO website.

## Introduction

It is often impractical to establish the suitability of a linear motion rolling bearing selected for a specific application by testing. The following procedures have proved to be an appropriate and convenient substitute for testing:

- life calculation with dynamic load (ISO 14728-1);
- static load safety factor calculation with static load (ISO 14728-2).

The life of a linear motion bearing is given by the distance which one of the raceways moves, in relation to the other raceway, before the first evidence of fatigue develops in the material of one of the raceways or one of the rolling elements.

The formulae for calculating the basic dynamic load ratings are derived from the theory of Lundberg<sup>[7]</sup> and Palmgren<sup>[8]</sup>.



# Rolling bearings — Linear motion rolling bearings —

## Part 1: Dynamic load ratings and rating life

### 1 Scope

This document specifies methods of calculating the basic dynamic load rating and basic rating life for linear motion rolling bearings manufactured from contemporary, commonly used, high quality, hardened bearing steel in accordance with good manufacturing practice and basically of conventional design as regards the shape of the rolling contact surfaces. The life of linear motion rolling bearings is defined and the conditions are established for reliable life calculations.

This document is not applicable to designs where the rolling elements operate directly on the slide surface of the machine equipment, unless that surface is equivalent in all respects to the raceway of the linear motion rolling bearing component it replaces.

### 2 Normative references

There are no normative references in this document.

### 3 Terms and definitions

For the purposes of this document, the terms and definitions given in ISO 281 and ISO 5593, and the following apply.

ISO and IEC maintain terminological databases for use in standardization at the following addresses:

- IEC Electropedia: available at <http://www.electropedia.org/>
- ISO Online browsing platform: available at <http://www.iso.org/obp>

#### 3.1

##### **recirculating linear ball bearing, sleeve type, with or without raceway grooves**

basically cylindrical sleeve provided with a number of closed loops of recirculating balls designed to achieve linear rolling motion along a hardened cylindrical shaft

Note 1 to entry: See [Figure 1](#).

Note 2 to entry: The raceways in the sleeve can be designed cylindrical as well as steel inserts with raceway grooves parallel to the axis.

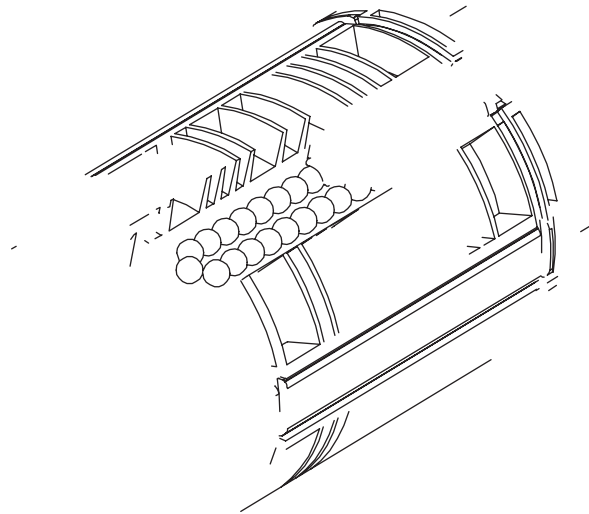

**Figure 1 — Recirculating linear ball bearing, sleeve type**

**3.2**

**recirculating linear ball (or roller) bearing, linear guideway, carriage type**

linear ball (or roller) bearing provided with a number of symmetrically arranged, closed loops of recirculating balls (or rollers) designed to achieve linear rolling motion along a hardened guideway furnished with adequate raceways

Note 1 to entry: See [Figure 2](#).

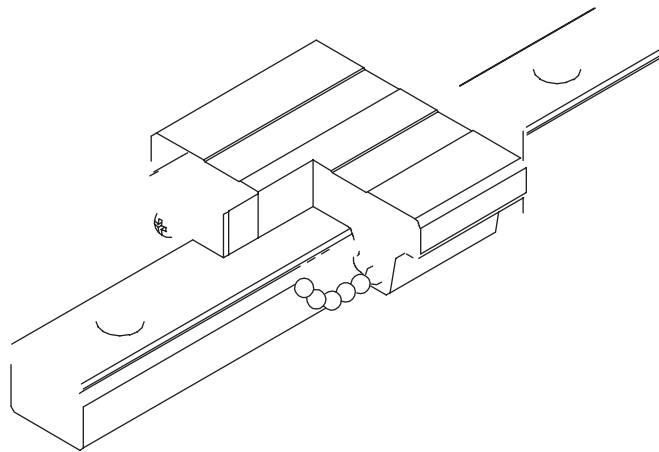

**Figure 2 — Recirculating linear ball (or roller) bearing, linear guideway, carriage type**



**3.3****non-recirculating linear ball bearing, linear guideway, deep groove type**

linear bearing with balls as rolling elements, each ball having two points of contact

Note 1 to entry: See [Figure 3](#).

Note 2 to entry: The cross-sectional radii of the raceway grooves in the two guideways are equal and may lie between  $0,52 D_w$  and infinity.

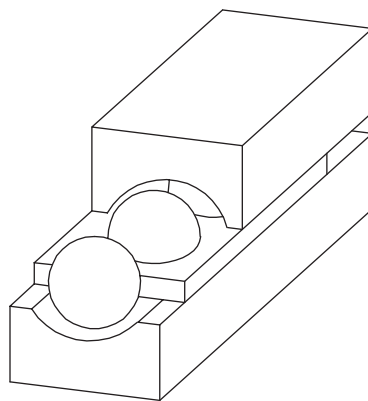

**Figure 3 — Non-recirculating linear ball bearing, linear guideway, deep groove type**

**3.4****non-recirculating linear ball bearing, linear guideway, four-point-contact type**

linear bearing with balls as rolling elements, each ball having four points of contact

Note 1 to entry: See [Figure 4](#).

Note 2 to entry: The cross-sectional radii of the raceway grooves for the four points of contact in the two guideways are equal and may lie between  $0,52 D_w$  and infinity.

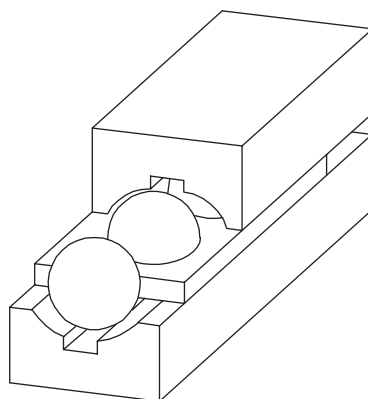

**Figure 4 — Non-recirculating linear ball bearing, linear guideway, four-point-contact type**

3.5

**non-recirculating linear roller bearing, linear guideway, flat type**

linear bearing with needle rollers or cylindrical rollers as rolling elements

Note 1 to entry: See [Figure 5](#).

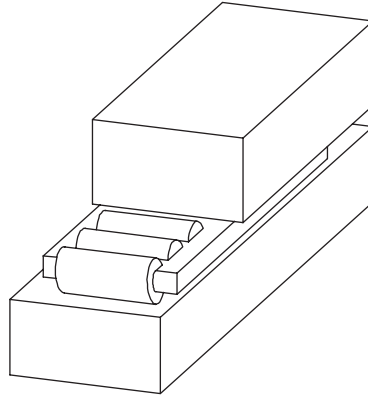

**Figure 5 — Non-recirculating linear roller bearing, linear guideway, flat type**

3.6

**non-recirculating linear roller bearing, linear guideway, V-angle type**

linear bearing with guideways designed as parts of a V with a 90° angle

Note 1 to entry: See [Figure 6](#).

Note 2 to entry: Needle rollers or cylindrical rollers are used as rolling elements.

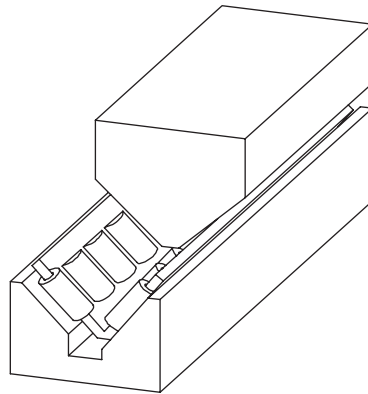

**Figure 6 — Non-recirculating linear roller bearing, linear guideway, V-angle type**

**3.7****non-recirculating linear roller bearing, linear guideway, crossed roller type**  
linear bearing with cylindrical rollers arranged in a crossed roller construction

Note 1 to entry: See [Figure 7](#).

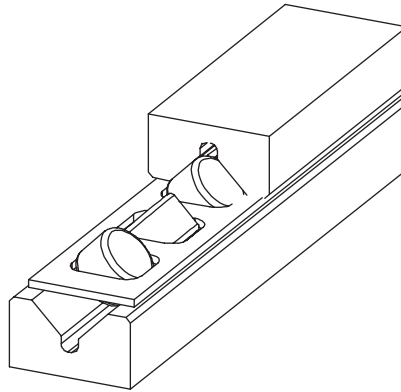

**Figure 7 — Non-recirculating linear roller bearing, linear guideway, crossed roller type**

**3.8****life**

<for an individual linear motion rolling bearing> distance one of the raceways moves in relation to the other raceway before the first evidence of fatigue develops in the material of one of the raceways or one of the rolling elements

**3.9****reliability**

<for a group of apparently identical linear motion rolling bearings operating under the same conditions> percentage of the group that is expected to attain or exceed a specified life

Note 1 to entry: The reliability of an individual linear motion rolling bearing is the probability that the bearing will attain or exceed a specified life.

**3.10****basic rating life**

<for an individual linear motion rolling bearing or a group of apparently identical linear motion rolling bearings operating under the same conditions> life associated with 90 % reliability, with contemporary, commonly used material and manufacturing quality and under conventional operating conditions

**3.11****basic dynamic load rating of a linear motion rolling bearing**

constant stationary load that a linear motion rolling bearing could theoretically endure for a basic rating life of  $10^5$  m

Note 1 to entry: If a basic rating life of  $5 \times 10^4$  m is used to define the basic dynamic load rating, then a conversion factor should be used as shown below:

— for basic dynamic load rating of linear ball bearings:

$$C_{100B} = \frac{C_{50B}}{1,26}$$

— for basic dynamic load rating of linear roller bearings:

$$C_{100R} = \frac{C_{50R}}{1,23}$$

**3.12 dynamic equivalent load**

constant stationary load under the influence of which a linear motion rolling bearing would have the same life as it would attain under the actual load conditions

**3.13 direction of load**

direction of load applied for load rating calculation

Note 1 to entry: For calculation of basic dynamic load ratings, the direction of the load is defined for all linear motion bearings as shown by the arrows in [Figure 8](#).

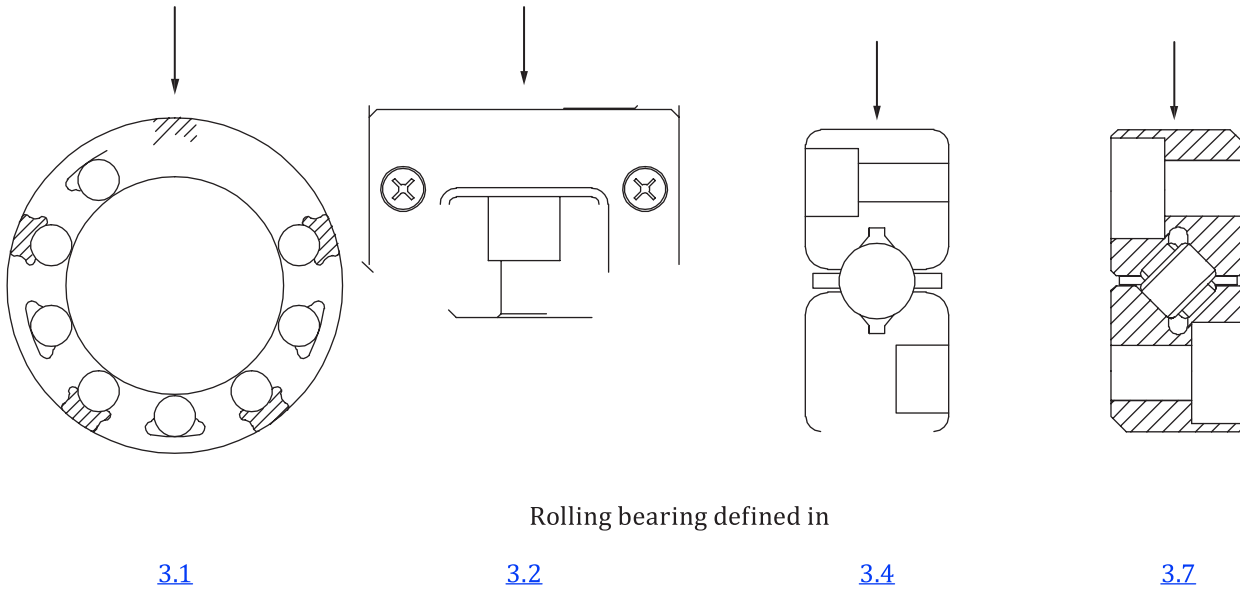

**Figure 8 — Direction of load**

**3.14 pitch diameter**

<of recirculating linear ball bearing, sleeve type> diameter of the circle containing the centres of the balls in contact with the raceways, in a plane perpendicular to the bearing axis

**3.15 nominal contact angle**

angle between the direction of load on the linear bearing and the nominal line of action of the resultant of the forces transmitted by a bearing raceway member to a rolling element

Note 1 to entry: See [Figure 9](#).

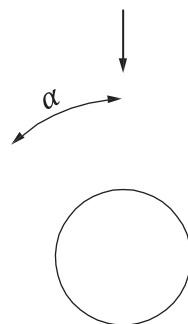

**Figure 9 — Nominal contact angle**

## 4 Symbols

For the purposes of this document, the symbols given in ISO 281, ISO 15241 and [Table 1](#) apply.

**Table 1 — Symbols, terms and units**

Symbol	Term	Unit
$b_m$	Rating factor for contemporary, commonly used, high quality, hardened bearing steel in accordance with good manufacturing practice, the value of which varies with bearing type and design	1
$C$	Basic dynamic load rating	N
$C_0$	Basic static load rating	N
$C_{50B}$	Basic dynamic load rating for linear ball bearings calculated for a basic rating life of $5 \times 10^4$ m	N
$C_{50R}$	Basic dynamic load rating for linear roller bearings calculated for a basic rating life of $5 \times 10^4$ m	N
$C_{100B}$	Basic dynamic load rating for linear ball bearings calculated for a basic rating life of $10^5$ m	N
$C_{100R}$	Basic dynamic load rating for linear roller bearings calculated for a basic rating life of $10^5$ m	N
$c_L$	Adjustment factor for recirculating linear ball bearings, sleeve type, with or without raceway grooves, applicable in the calculation of load ratings	1
$D_{pw}$	Pitch diameter of ball rows	mm
$D_w$	Ball diameter	mm
$D_{we}$	Roller diameter applicable in the calculation of load ratings	mm
$F$	Load on bearing	N
$f_c$	Factor that depends on the geometry of the bearing components, the accuracy to which the various components are made, and on the material	1
$f_s$	Correction factor for short stroke application, applicable for recirculating linear ball bearings, sleeve type with or without grooves, specified by the manufacturer	1
$i$	Number of rows of balls or rollers applicable in the calculation of load ratings NOTE In the case of recirculating linear bearings, sleeve type, it is the total number of rows of balls.	1
$i_t$	Number of load-carrying rows of balls in loaded zone $-90^\circ < \varphi_j < +90^\circ$ of recirculating linear ball bearings, sleeve type, with or without raceway grooves, applicable in the calculation of load ratings	1
$k_F$	Dynamic load factor	1
$k_i$	Factor for recirculating linear ball bearings, sleeve type, with or without raceway grooves, applicable in the calculation of load ratings	1
$L_{we}$	Roller length applicable in the calculation of load ratings	mm
$L_{10}$	Basic rating life associated with 90 % reliability	$10^5$ m
$l_s$	Travel length of linear bearings	mm
$l_t$	Raceway length applicable in the calculation of load ratings. For recirculating linear bearings, that of sleeve or carriage, determined by the manufacturer, and for non-recirculating linear bearings, that of guideway, equal to the centre distance between the load-carrying balls or rollers at both ends of one row	mm
$P$	Dynamic equivalent load	N
$p$	Exponent	1
$r_g$	Cross-sectional radius of the raceway groove on guideway	mm
$t_w$	Centre distance between two neighbouring balls or rollers	mm
$Z$	Number of balls or rollers in one row	1
$Z_t$	Number of load-carrying balls or rollers in one row applicable in the calculation of load ratings	1

**Table 1** (continued)

Symbol	Term	Unit
$\alpha$	Nominal contact angle	°
$\varphi_j$	Angle between the direction of load and the ball row $j$	°
$\lambda$	Reduction factor	1

## 5 Basic dynamic load ratings

### 5.1 Linear ball bearings

#### 5.1.1 Recirculating linear ball bearings, sleeve type with raceway grooves

The basic dynamic load rating for this bearing, in vertical loading position, is given in [Formula \(1\)](#):

$$C_{100B} = b_m \times f_c \times k_i \times l_t^{1/30} \times Z_t^{2/3} \times D_w^{2,1} \quad (1)$$

where

$$f_c = \lambda \times c_L \times 29,8 \left[ 2,18 \times \left( 1 - \frac{D_w}{D_{pw}} \right)^{-4,67} + \left( \frac{2 \times r_g}{2 \times r_g - D_w} \right)^{-1,37} \right]^{-0,3}$$

$$k_i = \frac{\sum_{j=1}^{j=i_t} (\cos \varphi_j)^{2,5}}{\left[ \sum_{j=1}^{j=i_t} (\cos \varphi_j)^5 \right]^{0,3}}$$

$$b_m = 1,3$$

$$\lambda = 0,9$$

$$c_L = 1 \text{ to } 1,2$$

In the number of load-carrying rows of balls in the loaded area,  $i_t$ , those rows which are arranged in an angular area of  $-90^\circ < \varphi_j < +90^\circ$  to the direction of normal load (see [Figure 8](#)) shall be taken into account.

The values of  $b_m$  and  $\lambda$  given above are the maximum values, smaller values may be used by the manufacturer.

The value of  $c_L$  is determined by the manufacturer in the range given above.

The values for  $k_i$  of recirculating linear ball bearing, sleeve type, with equally spaced ball rows, are given in [Table 2](#).

### 5.1.2 Recirculating linear ball bearings, sleeve type without raceway grooves

The basic dynamic load rating for this bearing, in vertical loading position, is given in [Formula \(2\)](#):

$$C_{100B} = b_m \times f_c \times k_i \times l_t^{1/30} \times Z_t^{2/3} \times D_w^{2,1} \quad (2)$$

where

$$f_c = \lambda \times c_L \times 22,9 \left[ 0,91 \times \left( 1 - \frac{D_w}{D_{pw}} \right)^{-4,67} + \left( 1 + \frac{D_w}{D_{pw}} \right)^{-1,67} \right]^{-0,3}$$

$$k_i = \frac{\sum_{j=1}^{j=i_t} (\cos \varphi_j)^{2,5}}{\left[ \sum_{j=1}^{j=i_t} (\cos \varphi_j)^5 \right]^{0,3}}$$

$$b_m = 1,3$$

$$\lambda = 0,9$$

$$c_L = 1 \text{ to } 1,2$$

In the number of load-carrying rows of balls in the loaded area,  $i_t$ , those rows which are arranged in an angular area of  $-90^\circ < \varphi_j < +90^\circ$  to the direction of normal load (see [Figure 8](#)) shall be taken into account.

The values of  $b_m$  and  $\lambda$  given above are the maximum values, smaller values may be used by the manufacturer.

The value of  $c_L$  is determined by the manufacturer in the range given above.

The values for  $k_i$  of recirculating linear ball bearing, sleeve type, with equally spaced ball rows, are given in [Table 2](#).

**Table 2 — Values of  $k_i$**

$i$	3	4	5	6	7	8	9	10
$k_i$	1,000	1,000	1,104	1,329	1,531	1,681	1,807	1,948

### 5.1.3 Recirculating linear ball bearings, linear guideway, carriage type

The basic dynamic load rating for this bearing is given in [Formula \(3\)](#):

$$C_{100B} = b_m \times f_c \times l_t^{1/30} \times i^{0,7} \times Z_t^{2/3} \times D_w^{2,1} \times \cos \alpha \quad (3)$$

where

$$f_c = \lambda \times 24,5 \times \left( \frac{2 \times r_g}{2 \times r_g - D_w} \right)^{0,41}$$

$$b_m = 1,3$$

$$\lambda = 0,9$$

The values of  $b_m$  and  $\lambda$  given above are the maximum values, smaller values may be used by the manufacturer.

The values of  $f_c$  calculated with  $\lambda = 0,9$  are given in [Table 3](#).

The load-carrying ability of a bearing is not necessarily increased by the use of smaller raceway groove radii, but it is reduced by the use of larger raceway groove radii than those indicated in [Table 3](#).

**Table 3 — Values of  $f_c$**

$r_g$	$f_c$
0,52 $D_w$	83,9
0,53 $D_w$	71,6
0,54 $D_w$	64,1
0,55 $D_w$	58,9
0,56 $D_w$	55,1
0,57 $D_w$	52,1
0,58 $D_w$	49,7
0,59 $D_w$	47,7
0,60 $D_w$	46,0

**5.1.4 Non-recirculating linear ball bearings, linear guideway, deep groove and four-point-contact types**

The basic dynamic load rating for these bearings is given in [Formula \(4\)](#):

$$C_{100B} = b_m \times f_c \times l_t^{1/30} \times i^{0,7} \times Z_t^{2/3} \times D_w^{2,1} \times \cos \alpha \tag{4}$$

where

$$f_c = \lambda \times 24,2 \times \left( \frac{2 \times r_g}{2 \times r_g - D_w} \right)^{0,41}$$

$$l_t = (Z_t - 1) \times t_w$$

$$b_m = 1,3$$

$$\lambda = 0,9$$

The values of  $b_m$  and  $\lambda$  given above are the maximum values, smaller values may be used by the manufacturer.

The values of  $i$  and  $Z_t$  are given in [Table 4](#).

**Table 4 — Values of  $i$  and  $Z_t$**

Bearing	$i$	$Z_t$
Deep groove type	1	$Z$
Four-point-contact type	2	$Z$



The values of  $f_c$  calculated with  $\lambda = 0,9$  are given in [Table 5](#).

**Table 5 — Values of  $f_c$**

$r_g$	$f_c$
0,52 $D_w$	82,8
0,53 $D_w$	70,7
0,54 $D_w$	63,3
0,55 $D_w$	58,2
0,56 $D_w$	54,4
0,57 $D_w$	51,5
0,58 $D_w$	49,1
0,59 $D_w$	47,1
0,60 $D_w$	45,4
$\infty$	21,8

## 5.2 Linear roller bearings

### 5.2.1 Recirculating linear roller bearings, linear guideway, carriage type

The basic dynamic load rating for this bearing is given in [Formula \(5\)](#):

$$C_{100B} = b_m \times f_c \times l_t^{1/36} \times i^{7/9} \times Z_t^{3/4} \times L_{we}^{7/9} \times D_{we}^{35/27} \times \cos \alpha \quad (5)$$

where

$$f_c = \lambda \times 195$$

$$b_m = 1,1$$

$$\lambda = 0,83$$

The values of  $b_m$  and  $\lambda$  given above are the maximum values, smaller values may be used by the manufacturer.

### 5.2.2 Non-recirculating linear roller bearings, linear guideway, flat, V-angle and crossed roller types

The basic dynamic load rating for these bearings is given in [Formula \(6\)](#):

$$C_{100B} = b_m \times f_c \times l_t^{1/36} \times i^{7/9} \times Z_t^{3/4} \times L_{we}^{7/9} \times D_{we}^{35/27} \times \cos \alpha \quad (6)$$

where

$$f_c = \lambda \times 194$$

$$l_t = (Z_t - 1) \times t_w$$

$$b_m = 1,1$$

$$\lambda = 0,83$$

The values of  $b_m$  and  $\lambda$  given above are the maximum values, smaller values may be used by the manufacturer.

The values of  $i$  and  $Z_t$  are given in [Table 6](#).

**Table 6 — Values of  $i$  and  $Z_t$**

Bearing	$i$	$Z_t$
Flat type	1	$Z$
V-angle type	2	$Z$
Crossed roller type	2	$Z/2$

## 6 Dynamic equivalent load

The dynamic equivalent load for a linear motion rolling bearing is given in [Formula \(7\)](#):

$$P = k_F \times F \tag{7}$$

The dynamic load factor  $k_F$  is taken to be one ( $k_F = 1$ ) when the direction of bearing load,  $F$ , is normal (as shown in [Figure 8](#)) and bearing clearance is in the normal range. For bearing load directions other than normal and/or with additional torque loads, the values of  $k_F$  should be specified by the bearing manufacturer.

## 7 Basic rating life

The basic rating life for a linear motion rolling bearing is given in [Formula \(8\)](#) for the two bearing types:

$$L_{10} = \left( \frac{C}{P} \right)^p \tag{8}$$

The values of  $p$  are given in [Table 7](#).

**Table 7 — Values of  $p$**

Bearing type	$p$
Linear ball bearing	3
Linear roller bearing	10/3

The conditions established for reliable life calculations are as follows:

Dynamic equivalent load:

$$P \leq 0,5C$$

$$P \leq C_0$$

Applied stroke for all types of recirculating linear ball (or roller) bearings:

$$l_s \geq 2l_t$$

Applied stroke for all types of non-recirculating linear ball (or roller) bearings:

$$l_s \leq l_t$$

and when the balls or rollers stroke within the raceway in the rolling direction.

The life of recirculating linear ball bearings, sleeve type is influenced by applied shorter stroke as defined above and can be adapted in [Formula \(9\)](#):

$$L_{10} = f_s \left( \frac{C}{P} \right)^p \quad (9)$$

where

$$f_s = f \left( \frac{l_s}{l_t} \right)$$

The correction factor  $f_s$  shall be specified by the manufacturer.

## Bibliography

- [1] ISO 281, *Rolling bearings — Dynamic load ratings and rating life*
- [2] ISO 5593, *Rolling bearings — Vocabulary*
- [3] ISO 12090-1, *Rolling bearings — Profiled rail guides for linear motion rolling bearings — Part 1: Boundary dimensions and tolerances for series 1, 2 and 3*
- [4] ISO 12090-2, *Rolling bearings — Profiled rail guides for linear motion rolling bearings — Part 2: Boundary dimensions and tolerances for series 4 and 5*
- [5] ISO 10285, *Rolling bearings — Sleeve type linear ball bearings — Boundary dimensions and tolerances*
- [6] ISO 15241, *Rolling bearings — Symbols for physical quantities*
- [7] LUNDBERG G., & PALMGREN A. *Dynamic capacity of rolling bearings*, Acta Polytechnica, Mechanical Engineering Series, Royal Swedish Academy of Engineering Sciences, Vol. 1, No. 3 (1947)
- [8] LUNDBERG G., & PALMGREN A. *Dynamic capacity of roller bearings*, Acta Polytechnica, Mechanical Engineering Series, Royal Swedish Academy of Engineering Sciences, Vol. 2, No. 4 (1952)



