

INTERNATIONAL STANDARD

ISO
14679

First edition
1997-09-15

Adhesives — Measurement of adhesion characteristics by a three-point bending method

Adhésifs — Détermination des caractéristiques d'adhésion par une méthode de flexion à trois points

This material is reproduced from ISO documents under International Organization for Standardization (ISO) Copyright License number IHS/ICC/1996. Not for resale. No part of these ISO documents may be reproduced in any form, electronic retrieval system or otherwise, except as allowed in the copyright law of the country of use, or with the prior written consent of ISO (Case postale 56, 1211 Geneva 20, Switzerland, Fax +41 22 734 10 79), IHS or the ISO Licensor's members.



Reference number
ISO 14679:1997(E)

ISO 14679:1997(E)**Foreword**

ISO (the International Organization for Standardization) is a worldwide federation of national standards bodies (ISO member bodies). The work of preparing International Standards is normally carried out through ISO technical committees. Each member body interested in a subject for which a technical committee has been established has the right to be represented on that committee. International organizations, governmental and non-governmental, in liaison with ISO, also take part in the work. ISO collaborates closely with the International Electrotechnical Commission (IEC) on all matters of electrotechnical standardization.

Draft International Standards adopted by the technical committees are circulated to the member bodies for voting. Publication as an International Standard requires approval by at least 75 % of the member bodies casting a vote.

International Standard ISO 14679 was prepared by Technical Committee ISO/TC 61, *Plastics*, Subcommittee SC 11, *Products*.

It is technically similar but not identical to ENV 1966:1995.

© ISO 1997

All rights reserved. Unless otherwise specified, no part of this publication may be reproduced or utilized in any form or by any means, electronic or mechanical, including photocopying and microfilm, without permission in writing from the publisher.

International Organization for Standardization
Case postale 56 • CH-1211 Genève 20 • Switzerland
Internet central@iso.ch
X.400 c=ch; a=400net; p=iso; o=isocs; s=central

Printed in Switzerland

Adhesives – Measurement of adhesion characteristics by a three-point bending method

1 Scope

This International Standard specifies a test method to determine the ability of a cured adhesive (if necessary with a primer) to adhere to a substrate with a certain surface finish, or which has been subjected to a specific surface preparation, using the “three-point bending method”.

This standard is only applicable to quality assurance and only to substrates which are rigid or resistant enough to bending, such as steel or aluminium alloys. For other substrates, the thickness is adjusted to the modulus of elasticity or a suitable stiffener is used.

The adhesive is allowed to cure without the application of pressure in order to obtain the thickness needed to provide sufficient rigidity, otherwise a bonded reinforcing piece of the same material and the same thickness as the substrate is substituted for the block of adhesive.

This test method is not suitable for film adhesives.

2 Normative references

The following standards contain provisions which, through reference in this text, constitute provisions of this International Standard. At the time of publication, the editions indicated were valid. All standards are subject to revision, and parties to agreements based on this International Standard are encouraged to investigate the possibility of applying the most recent editions of the standards indicated below. Members of IEC and ISO maintain registers of currently valid International Standards.

ISO 286-1:1988, *ISO system of limits and fits - Part 1: Bases of tolerances, deviations and fits.*

ISO 4588:1995, *Adhesives - Guidelines for the surface preparation of metals.*

ISO 9142:1990, *Adhesives - Guide to the selection of standard laboratory ageing conditions for testing bonded joints.*

ISO 10365:1992, *Adhesives - Designation of main failure patterns.*

ISO 13895:1996, *Adhesives - Guidelines for the surface preparation of plastics.*

3 Definition

For the purposes of this International Standard, the following definition applies:

interfacial zone: The zone between the adhesive and substrate, adhesive and coating or coating and substrate, where the physical, chemical and mechanical properties are different from those of substrate, the adhesive or any coating applied before bonding (see figure 1).

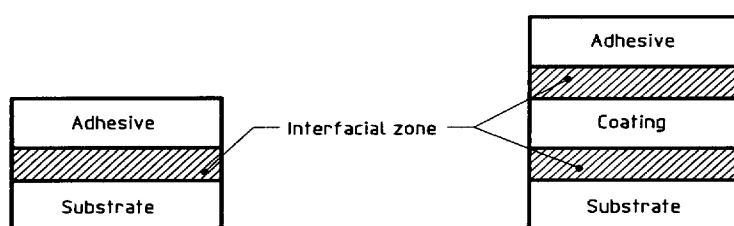

Figure 1 — Schematic diagram of test specimens showing the interfacial region

4 Principle

A specimen consisting of a substrate at the centre of which a rectangular block of adhesive has been moulded, thus giving a single substrate/interfacial zone/adhesive zone, is subjected to bending (see figure 2). The force-deformation curve is recorded and, from this curve, the maximum force and maximum specimen deformation are determined (these values correspond to the initiation of fracture, i.e. the moment when clear space is just visible between the adhesive and the substrate). They represent the adhesive power of the adhesive.

Note 1 The block of adhesive modifies the rigidity of the substrate in the area covered by the block. When the specimen is bent, therefore, a fracture is produced in the interfacial zone, at the edge of the block of adhesive, chiefly as a result of the adhesive forces acting perpendicular to the plane of bonding.

Note 2 As a general rule, the adhesive will be sufficiently rigid for adhesion failure to occur at the interfacial zone.

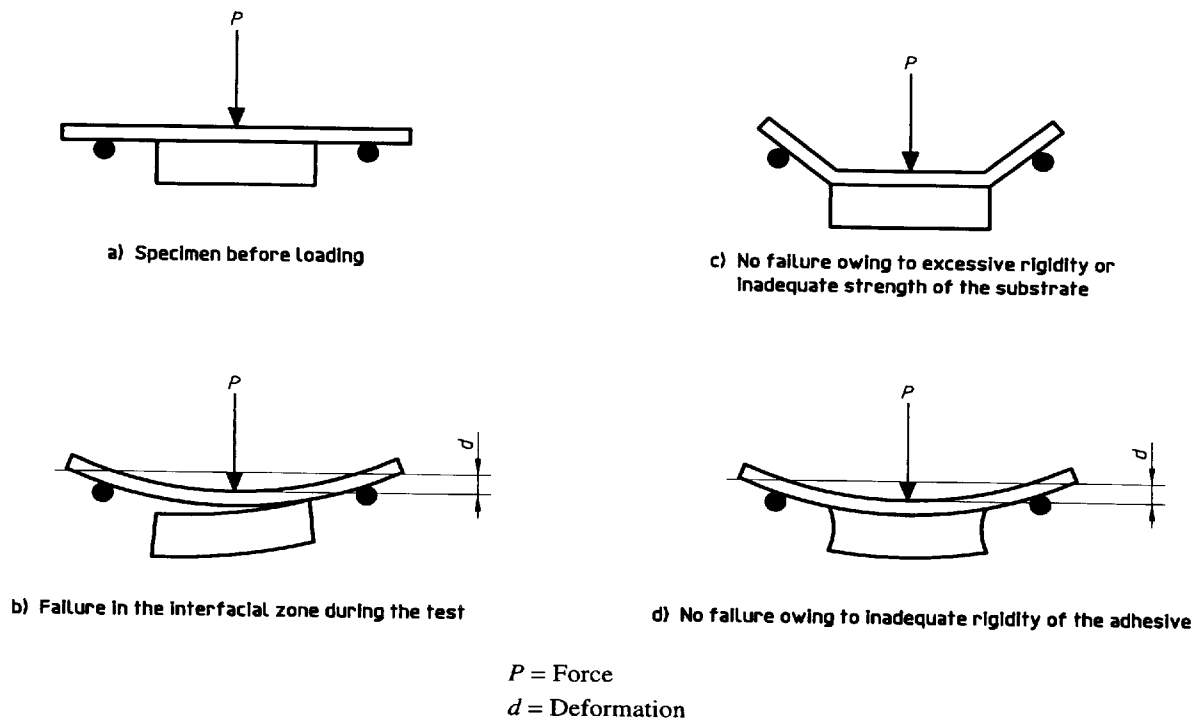

Figure 2 — Principle of the test

5 Apparatus

5.1 Specimen preparation device (see figure 3), consisting of the following three elements:

- located underneath, an aluminium alloy plate (see figure 4) with substrate seatings positioned at regular intervals;
- in the centre, a silicone rubber mould (see figure 5) containing adhesive-moulding cells, of dimensions equal to those required for the blocks of adhesive, above the substrate seatings and obtained from a negative mould;
- on top, an aluminium alloy securing plate (see figure 6), with cutouts above the cells to allow them to be filled.

The whole assembly is held together by bolting the lower plate to the securing plate, thus ensuring that the silicone rubber mould fits tightly against the lengths of substrate.

5.2 Syringe, graduated in 1/100ths of a cubic centimetre, or some other suitable device capable of placing a constant amount of adhesive in each cell.

5.3 Bending machine, capable of fracturing the specimen at between 10% and 80% of the full-scale reading of the force-indicating instrument. The rate of displacement of the moving head shall be 0,5 mm/min +/- 0,001 mm/min.

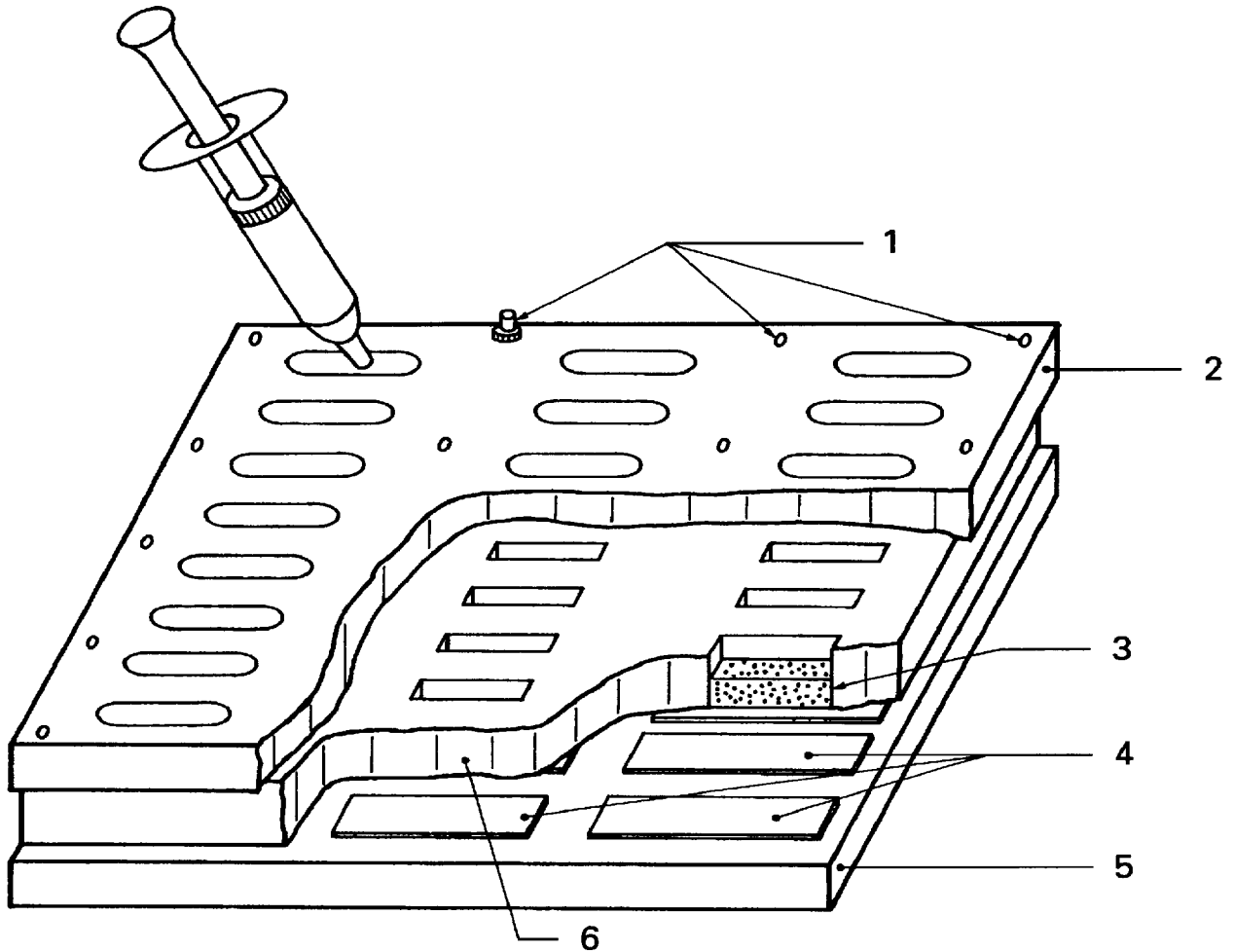

Key

- | | | | |
|---|---------------------|---|-----------------------|
| 1 | Securing bolts (20) | 4 | Substrates |
| 2 | Securing plate | 5 | Lower plate |
| 3 | Adhesive | 6 | Silicone rubber mould |

Figure 3 — Specimen preparation device

Dimensions in millimetres

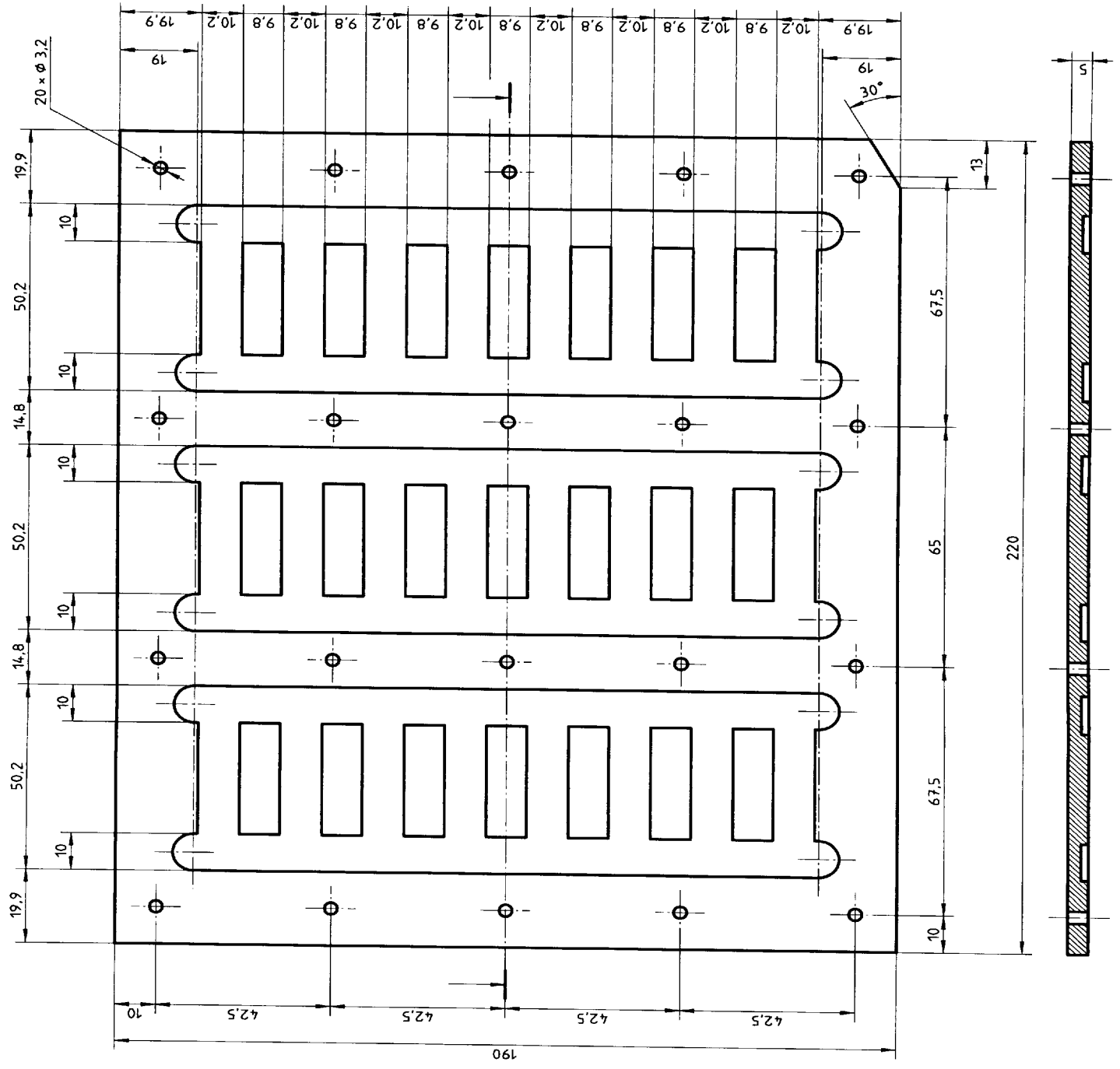

Standard tolerance grade 7 (IT7) as defined in ISO 286-1.

Figure 4 — Lower plate

Dimensions in millimetres

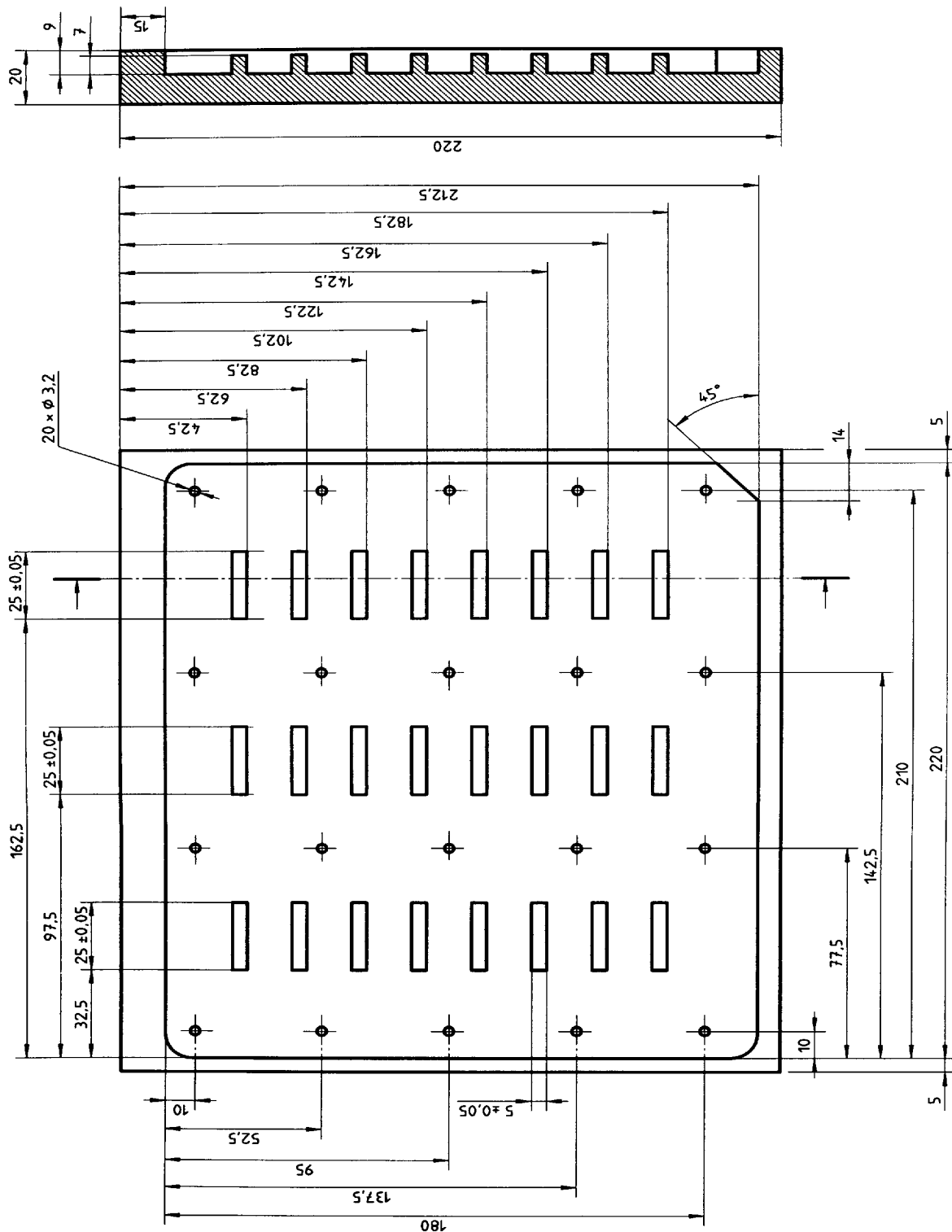

Standard tolerance grade 7 (IT7) as defined in ISO 286-1.

Figure 5 — Silicone rubber mould

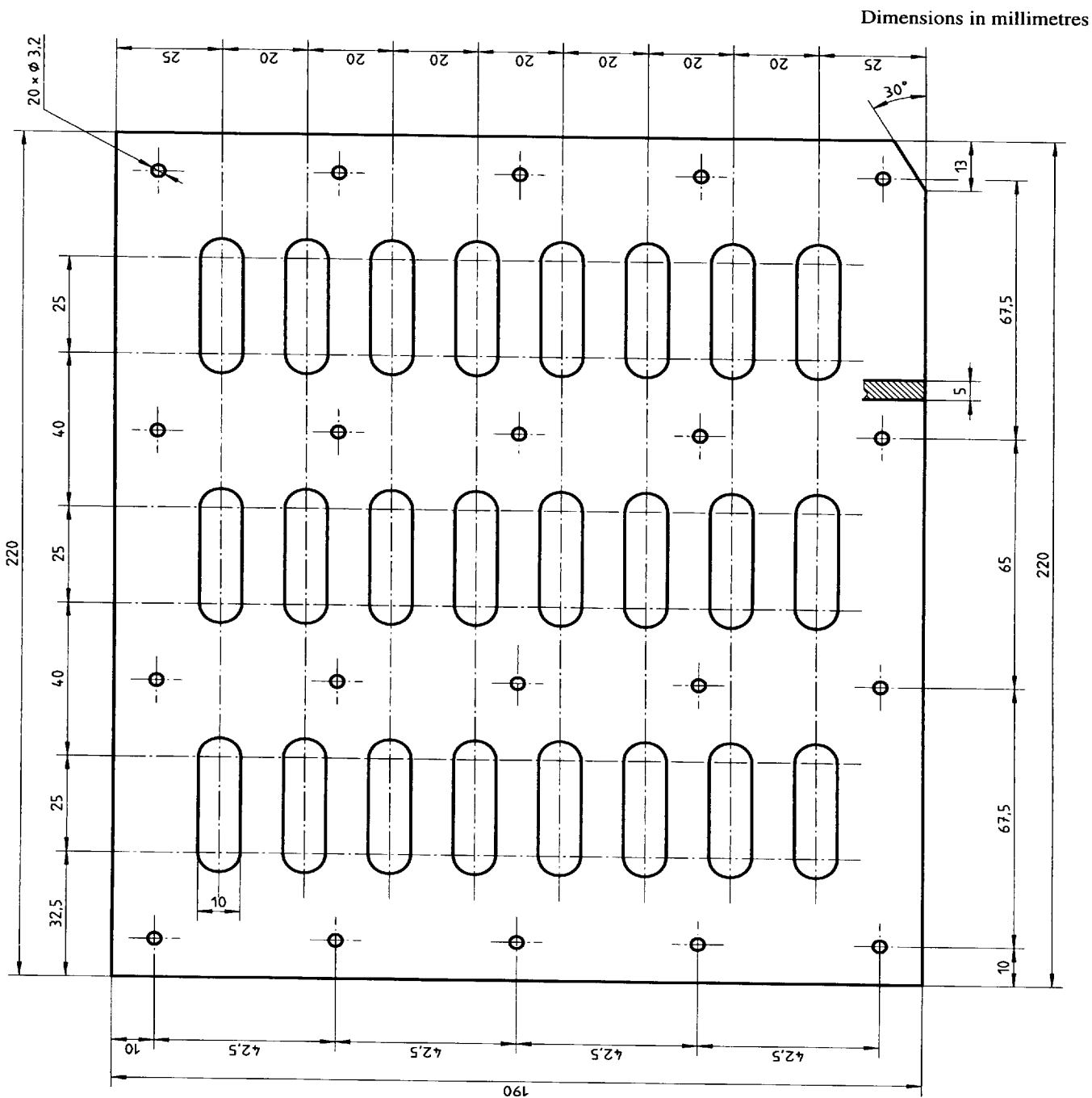

Standard tolerance grade 7 (IT7) as defined in ISO 286-1.

Figure 6 — Securing plate

5.4 Test rack (see figure 7), comprising two rigid support bars and a central load-application bar, disposed symmetrically so that the specimen can be centered perpendicular to the line of displacement of the load-application bar. The support bars shall be 6 mm in diameter and positioned 33 mm apart. The load-application bar shall have a diameter of 12 mm. The lengths of all three bars shall be over 15 mm.

Dimensions in millimetres

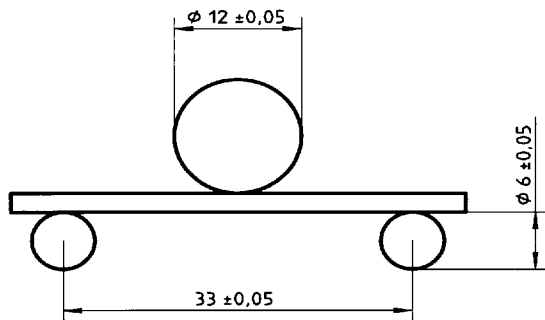

Figure 7 — Test rack

5.5 Measurement equipment, capable of measuring the force acting on the specimen with an accuracy of 1% and the deformation of the specimen with an accuracy of 0,001 mm.

6 Specimens (see figure 8)

6.1 Dimensions

Each specimen shall comprise a substrate measuring $(50 \pm 0,1)$ mm x $(10 \pm 0,1)$ mm x $(e \pm 0,02)$ mm (see note 3), die-stamped in one piece or cut by some other means affording adequate precision and surface evenness, plus a block of adhesive moulded on to the centre of each substrate and measuring $(25 \pm 0,05)$ mm x $(5 \pm 0,05)$ mm x $(4 \pm 0,1)$ mm.

Note 3 The substrate thickness e will depend on the type of adhesive used and on its shrinkage, viscosity, etc.

Dimensions in millimetres

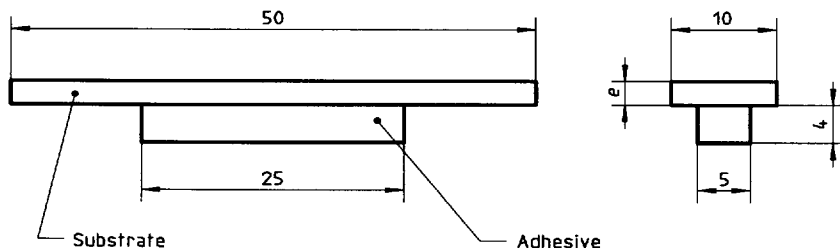

e = Thickness of substrate

Figure 8 — Specimen

6.2 Substrate material

The substrate shall be made of steel or aluminium alloy sheet.

Note 4 Suitable lengths of substrate may be made from 1-mm-thick type XC 18 or E 24 steel sheet, quality 1 or 2, or from 1,5-mm-thick type 2024 (AU 4 G 1 A 5 T 3) aluminium alloy sheet.

Other materials may be used, providing the thickness of the substrate is adjusted as a function of the modulus of elasticity of the material or the substrate is bonded to a suitable stiffener before testing.

6.3 Preparation of substrate surface before bonding

The surface of the substrate on to which the block of adhesive is to be moulded shall be prepared in accordance with ISO 4588 for metal substrates or ISO 13895 for plastics, or as specified in the referring standard.

6.4 Preparation of specimens

Perform the operations described in 6.4.1 and 6.4.2 at 23 °C +/- 2 °C and (50 +/- 5) % relative humidity.

6.4.1 Inserting the substrates

Following surface preparation, place the substrates on the seatings on the lower plate with the prepared side facing upwards. Place the silicone rubber mould on top of this assembly and screw it down tight with the securing plate. Make sure that the cells do not suffer from deformation.

6.4.2 Inserting the adhesive

Using the syringe or other suitable device, introduce 0,5 cm³ of adhesive into each cell, taking care that the adhesive makes complete contact with the substrate and the walls of the mould and that no air bubbles are occluded in the adhesive.

6.4.3 Curing

Allow the adhesive to cure in accordance with the instructions provided by the supplier of the adhesive.

6.4.4 Opening the mould

Remove the bolts from the lower plate and the securing plate and extract the specimens from the silicone rubber mould, pressing gently on the blocks of adhesive so as not to damage the interfacial zone.

6.4.5 Conditioning

Store the specimens for a minimum of 24 h at 23 °C +/- 2 °C and (50 +/- 5) % relative humidity before testing. Perform the test under the same conditions.

Any ageing carried out on the specimens before testing shall be in accordance with ISO 9142.

7 Procedure

Verify the dimensions of the specimens. Place a specimen on the support bars of the test rack, place the load-application bar carefully on the specimen and start the machine so that the load-application bar descends at a rate of 0,5 mm/min \pm 0,001 mm/min.

Record the force-displacement curve up to and beyond fracture.

Note the type of fracture propagation (slow or fast, continuous or intermittent).

In addition, observe and record the specimen failure pattern in accordance with ISO 10365, noting in addition the precise position of initiation of the fracture and the method of examination used (naked eye, magnifying glass, optical microscope, scanning electron microscope, etc.).

Test at least six specimens.

After each series of tests, carry out the test on an unbonded specimen (substrate only) which has been subjected to the same surface preparation procedure.

8 Expression of results

From each of the force-displacement curves recorded (see figure 9), extract and note the following information:

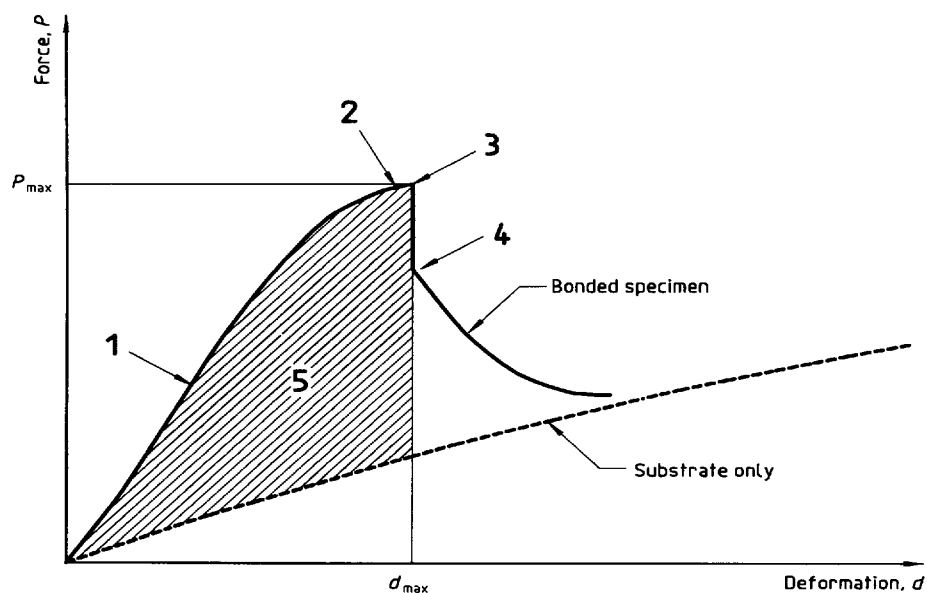

Key

- | | |
|-----------------------|---|
| 1 Maximum slope | 4 Fracture propagation |
| 2 Maximum force | 5 Area enclosed between curves for bonded specimen and substrate only |
| 3 Maximum deformation | |

Figure 9 — Force-deformation curve

- the slope P/d of the curve in the linear region corresponding to the first part of the recording or, in the absence of a linear region, the maximum value of the gradient of the curve (this value corresponds to the compliance of the specimen);
- the values of the force and displacement, P_{\max} and d_{\max} , at the moment of initiation of fracture;
- the area enclosed between the curve for the bonded specimen, the curve for the substrate only and the ordinate to the x -axis at d_{\max} .

If the failure is initiated in the interfacial region, the maximum values of the force and deformation and the area enclosed will be a measure of the adhesive power of the adhesive. However, if the fracture begins inside the block of adhesive, these parameters are linked to the cohesive power of the adhesive and are not therefore a measure of the adhesive power.

9 Test report

The test report shall include following information:

- a) a reference to this International Standard;
- b) all details necessary for complete identification of the adhesive and details of its method of use;
- c) all details necessary for complete identification of the substrate material used;
- d) the substrate thickness;
- e) a detailed description of the surface preparation carried out before bonding;
- f) the adhesive-curing conditions;
- g) details of the conditioning and any ageing carried out before testing;
- h) the number of specimens tested;
- i) details of the test machine and force-indicating instrument used (including rigidity and sensitivity);
- j) the results obtained, expressed in accordance with clause 8;
- k) the specimen failure pattern, position of initiation of fracture and method used to examine the specimens;
- l) the date of the test.

ICS 83.180

Descriptors: plastics, adhesives, adhesive bonded joints, tests, adhesion tests, bend tests, measurement, adhesion.

Price based on 11 pages
