

INTERNATIONAL STANDARD

ISO 14678

First edition
2005-08-15

Adhesives — Determination of resistance to flow (sagging)

Adhésifs — Détermination de la résistance au fluage (coulure)



Reference number
ISO 14678:2005(E)

© ISO 2005

PDF disclaimer

This PDF file may contain embedded typefaces. In accordance with Adobe's licensing policy, this file may be printed or viewed but shall not be edited unless the typefaces which are embedded are licensed to and installed on the computer performing the editing. In downloading this file, parties accept therein the responsibility of not infringing Adobe's licensing policy. The ISO Central Secretariat accepts no liability in this area.

Adobe is a trademark of Adobe Systems Incorporated.

Details of the software products used to create this PDF file can be found in the General Info relative to the file; the PDF-creation parameters were optimized for printing. Every care has been taken to ensure that the file is suitable for use by ISO member bodies. In the unlikely event that a problem relating to it is found, please inform the Central Secretariat at the address given below.

© ISO 2005

All rights reserved. Unless otherwise specified, no part of this publication may be reproduced or utilized in any form or by any means, electronic or mechanical, including photocopying and microfilm, without permission in writing from either ISO at the address below or ISO's member body in the country of the requester.

ISO copyright office
Case postale 56 • CH-1211 Geneva 20
Tel. + 41 22 749 01 11
Fax + 41 22 749 09 47
E-mail copyright@iso.org
Web www.iso.org

Published in Switzerland

Foreword

ISO (the International Organization for Standardization) is a worldwide federation of national standards bodies (ISO member bodies). The work of preparing International Standards is normally carried out through ISO technical committees. Each member body interested in a subject for which a technical committee has been established has the right to be represented on that committee. International organizations, governmental and non-governmental, in liaison with ISO, also take part in the work. ISO collaborates closely with the International Electrotechnical Commission (IEC) on all matters of electrotechnical standardization.

International Standards are drafted in accordance with the rules given in the ISO/IEC Directives, Part 2.

The main task of technical committees is to prepare International Standards. Draft International Standards adopted by the technical committees are circulated to the member bodies for voting. Publication as an International Standard requires approval by at least 75 % of the member bodies casting a vote.

Attention is drawn to the possibility that some of the elements of this document may be the subject of patent rights. ISO shall not be held responsible for identifying any or all such patent rights.

ISO 14678 was prepared by the European Committee for Standardization (CEN) in collaboration with Technical Committee ISO/TC 61, *Plastics*, Subcommittee SC 11, *Products*, in accordance with the Agreement on technical cooperation between ISO and CEN (Vienna Agreement).

Throughout the text of this document, read “...this European Standard...” to mean “...this International Standard...”.

Contents

	Page
Foreword.....	v
Introduction.....	vi
1 Scope	1
2 Normative references	1
3 Terms and definitions	1
4 Guidance: Typical applications for the seven test methods are as follows:	2
5 Sampling	2
6 Safety	2
7 Method 1: Use of an applicator to apply a wet film	2
8 Method 2: Use of a plug former	6
9 Method 3: Use of a scraper	11
10 Method 4: Use of test blocks	13
11 Method 5: Flow from a lap joint.....	17
12 Method 6: Flow of adhesive through a hole.....	20
13 Method 7: Flow of structural adhesive films.....	21

Foreword

This European Standard (EN ISO 14678:2005) has been prepared by Technical Committee CEN/TC 193 "Adhesives", the secretariat of which is held by AENOR, in collaboration with Technical Committee ISO/TC 61 "Plastics, Subcommittee SC 11, Products".

This European Standard shall be given the status of a national standard, either by publication of an identical text or by endorsement, at the latest by February 2006, and conflicting national standards shall be withdrawn at the latest by February 2006.

According to the CEN/CENELEC Internal Regulations, the national standards organizations of the following countries are bound to implement this European Standard: Austria, Belgium, Cyprus, Czech Republic, Denmark, Estonia, Finland, France, Germany, Greece, Hungary, Iceland, Ireland, Italy, Latvia, Lithuania, Luxembourg, Malta, Netherlands, Norway, Poland, Portugal, Slovakia, Slovenia, Spain, Sweden, Switzerland and United Kingdom

Introduction

When an adhesive joint is prepared, it is important that the applied adhesive does not flow away from the area of the joint. Flow can occur before the joint has been assembled, e.g. before solvent or water has evaporated, or after the joint has been closed, but before the adhesive has set, e.g. during the curing, solidification, or drying process.

The flow of an applied adhesive will be influenced by the stress applied and the duration and temperature of the bonding process. The extent of flow of an adhesive will also be influenced by the surface energies involved and the degree of roughness of the adherents. The occurrence of flow under gravity is called sagging (see Clause 3).

This European Standard describes three types of test for the assessment of sagging. In the first type of test, which simulates the conditions before joint assembly, the extent of flow of an adhesive down a surface which is either vertical (Methods 1, 2 and 3) or at 60° to the horizontal (Method 4) is measured. In the second type of test, which simulates conditions after assembly (Methods 5 and 6), the flow of adhesive from a hole or slot is observed. The third type of test simulates conditions during the cure cycle for structural film adhesives (Method 7). The method appropriate to the type of adhesive and its consistency should be selected.

1 Scope

This European Standard describes seven methods for the assessment of the flow characteristics of adhesives after application at room temperature and during cure, by the measurement of sagging. These methods may be used both for specifying an adhesive and for quality control purposes.

2 Normative references

The following referenced documents are indispensable for the application of this document. For dated references, only the edition cited applies. For undated references the latest edition of the referenced document (including any amendments) applies.

EN 923:1998, *Adhesives — Terms and definitions*

EN 1067, *Adhesives — Examination and preparation of samples for testing*

EN 13887, *Structural Adhesives - Guidelines for surface preparation of metals and plastics prior to adhesive bonding*

EN ISO 15605, *Adhesives - Sampling (ISO 15605:2000)*

3 Terms and definitions

For the purposes of this European Standard, the terms and definitions given in EN 923:1998 together with the following apply.

3.1

flow

deformation of an adhesive or adhesive layer

3.2

sagging

downward movement of an adhesive film between the time of application and setting resulting in an uneven coating having a thick lower edge

NOTE The resulting sagging is usually restricted to a local area of a vertical surface.

4 Guidance: Typical applications for the seven test methods are as follows:

- * Method 1: Use of an applicator to apply a wet film (see Clause 7) - Resistance to flow after application.
- * Method 2: Use of a plug former (see Clause 8) - Resistance to sagging after application.
- * Method 3: Use of a scraper (see Clause 9) to apply a film of adhesive - Resistance to flow after application during cure.
- * Method 4: Use of test blocks (see Clause 10) to measure static flow of adhesives after application and during cure.
- * Method 5: Flow from a lap joint (see Clause 11) - Resistance to flow after application.
- * Method 6: Flow of adhesive through a hole (see Clause 12) - Resistance to dripping after application.
- * Method 7: Flow of structural adhesive films (see Clause 13) - Resistance to flow during the cure cycle.

5 Sampling

Take a sample of the product to be tested in accordance with EN ISO 15605. Examine and prepare this sample for testing in accordance with EN 1067, where applicable, depending on which of the seven test methods is to be employed.

6 Safety

Persons using this standard shall be familiar with normal laboratory practice.

This standard does not purport to address all the safety problems, if any, associated with its use.

It is responsibility of the user to establish safety and health practices and to ensure compliance with any European and national regulatory conditions.

7 Method 1: Use of an applicator to apply a wet film

7.1 Principle

A wet film of the adhesive of defined thickness and shape is applied to a flat horizontal surface of a substrate using an applicator. After application the test panel is placed vertically in the test atmosphere for a specified time. The extent of sagging of the applied adhesive is measured (using the top edge of the test panel as a reference).

7.2 Supplementary information

This method of test requires that the following supplementary information shall be specified when the method is performed:

- a) description of the test substrate;
- b) procedure for preparation of the test surface;
- c) details of the conditioning atmosphere;

- d) details of the test atmosphere;
- e) temperature;
- f) method of mixing of two-component adhesives and the time between mixing and application;
- g) method of application of the adhesive and the applicator gap size;

NOTE The wet film thickness given by an applicator is generally less than the depth of the gap.

- h) duration of the test.

7.3 Apparatus and materials

7.3.1 Test panel(s), of glass or other specified material. Dimensions of approximately (300 · 200) mm are convenient. Sufficient panels to allow for three strips of adhesive of similar thickness are required.

7.3.2 Applicator(s), of different gap sizes (or stencils and suitable applicators, if the nature of the adhesive requires this apparatus).

7.3.3 Enclosure(s), to provide the specified conditioning and/or test atmospheres.

7.4 Conditioning and pretreatment

Cut test panels as required. Thoroughly clean each panel and carry out any specified pretreatment. Condition the adhesive and the prepared test panels (if required) in the specified conditioning atmosphere.

NOTE If not otherwise specified, the recommended conditions are (23 ± 2) °C and (50 ± 5) % RH.

7.5 Procedure

Place a prepared test panel in a horizontal position and apply strips of the adhesive parallel to the longer edge (see Figure 1). Mark one of the longer edges as the reference edge and, as quickly as possible, measure the distance in millimetres of the further edge of each strip from it.

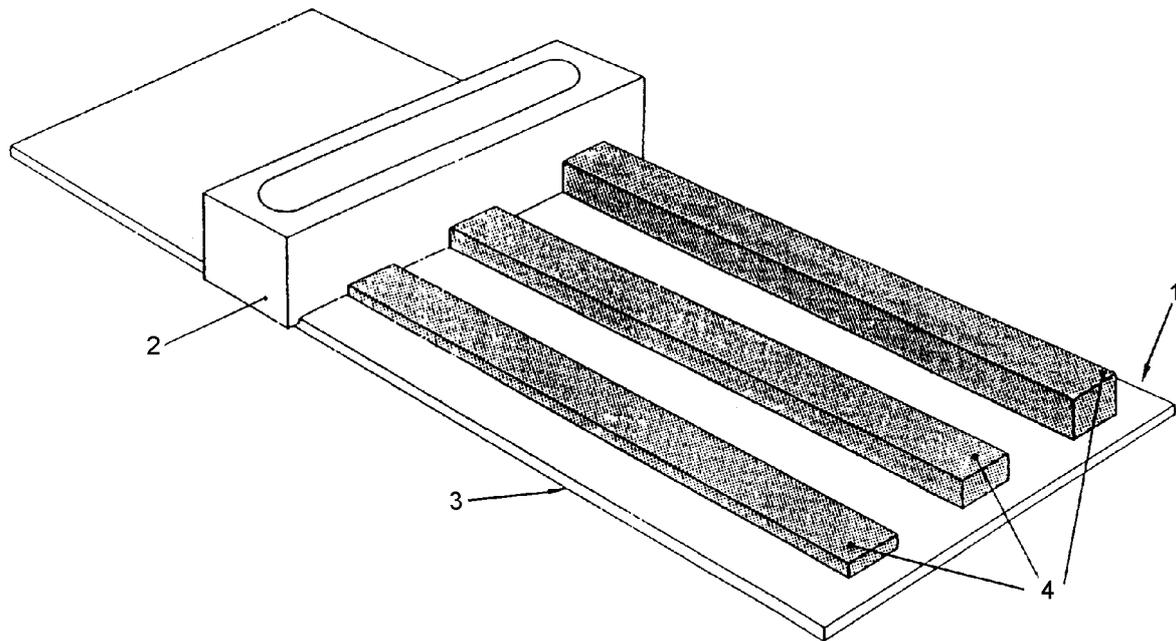

Key

- 1 Reference edge
- 2 Applicator
- 3 Test panel
- 4 Extruded strips

Figure 1 — Applicator for preparing adhesive strips (Method 1: Use of an applicator to apply a wet film)

Taking care to avoid vibration, mount the test panel within 2° of the vertical so that the strips are horizontal and the reference edge is at the top (see Figure 2). Place the panel in the test atmosphere for the specified time and then determine the sagging of the adhesive by measuring the maximum distance of flow of each strip from the reference edge.

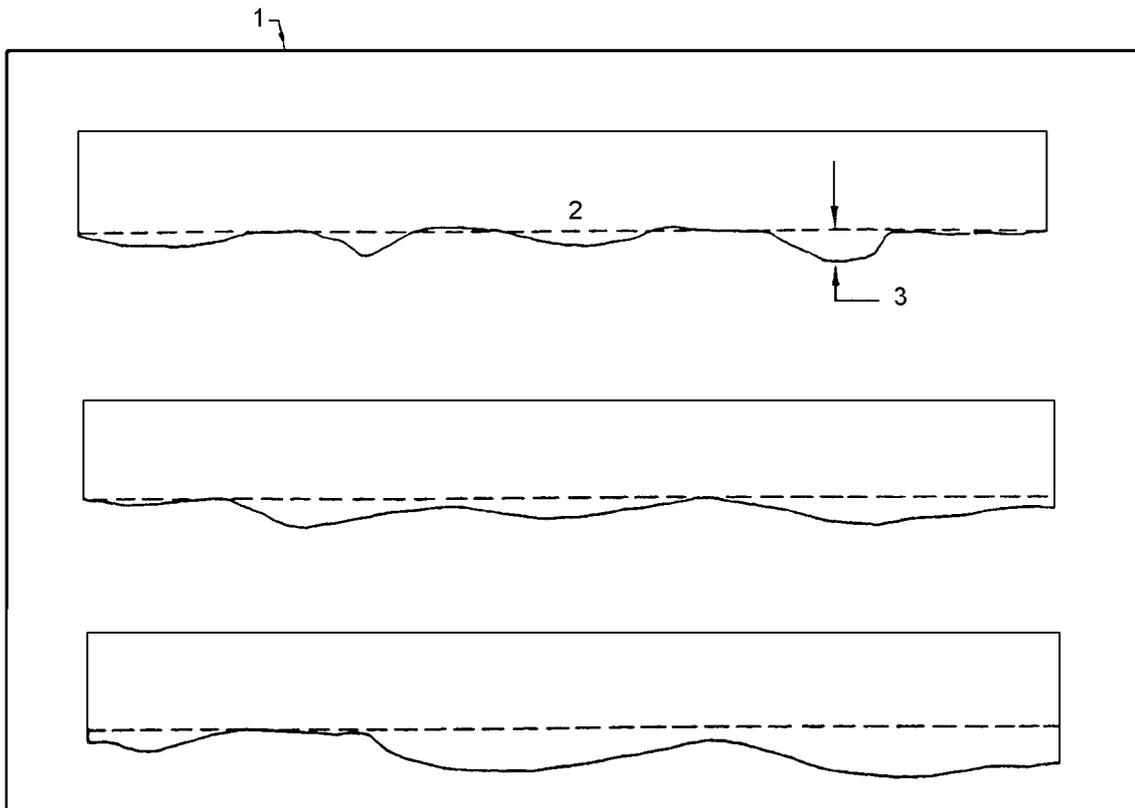

Key

- 1 Reference edge
- 2 Line of lower edge of strip before test
- 3 Maximum distance of flow

Figure 2 — Flow of adhesive strips (Method 1: Use of an applicator to apply a wet film)

NOTE The test panel may be reused only if the surface condition in the actual bonding process can be reproduced in the test.

Repeat the test for at least three strips at each applicator gap size.

7.6 Expression of results

For each strip calculate the sagging as the maximum difference in millimetres between the distance of the further edge of the strip from the reference edge before and after the test.

Express the result as the mean sagging in millimetres of the repeated tests at each specified applicator gap size.

7.7 Test report

The report shall state the following:

- a) reference to this European Standard;
- b) all information necessary for the complete identification of the adhesive;

- c) items of supplementary information given in 7.2;
- d) result for each applicator gap depth;
- e) that the method of test complied with the requirements of this standard, i.e. Method 1, or if it did not, the respects in which it did not comply;
- f) any operating details not specified in the method, as well as any incidents likely to have affected the results, such as, for example, phase separation, etc;
- g) date of the test.

8 Method 2: Use of a plug former

8.1 Principle

The adhesive is used to fill a cavity of known dimensions. The adhesive plug is then extruded and the apparatus is placed vertically in the test atmosphere for the specified time and the degree of sagging measured.

8.2 Supplementary information

This method of test requires that the following supplementary information shall be specified when the method is called up:

- a) details of the test atmosphere;
- b) details of the conditioning atmosphere;
- c) temperature;
- d) method of mixing of two-component adhesives and the time between mixing and application;
- e) duration of the test.

8.3 Apparatus and materials

8.3.1 Flow test apparatus. Block of metal, e.g. brass, light alloy or steel with a bright finish and overall dimensions not less than (100 · 50) mm.

The upper part of the block is drilled to provide a cylindrical cavity of diameter $(38 \pm 0,05)$ mm. The adhesive plug is extruded from the cavity by a solid plunger closely fitting the cavity and provided with means of positioning the face of the plunger flush with the face of the block and at a depth of $(9,5 \pm 0,05)$ mm. A graduated scale shall be marked or engraved on the lower face of the block. The first line shall be tangential to the lowest point of the circumference of the cavity and subsequent lines shall be spaced at $(1 \pm 0,1)$ mm or $(2 \pm 0,1)$ mm intervals over a distance of 50 mm. A suitable design is shown in Figure 3 with end plates fitted to support the block during filling.

Dimensions in millimetres

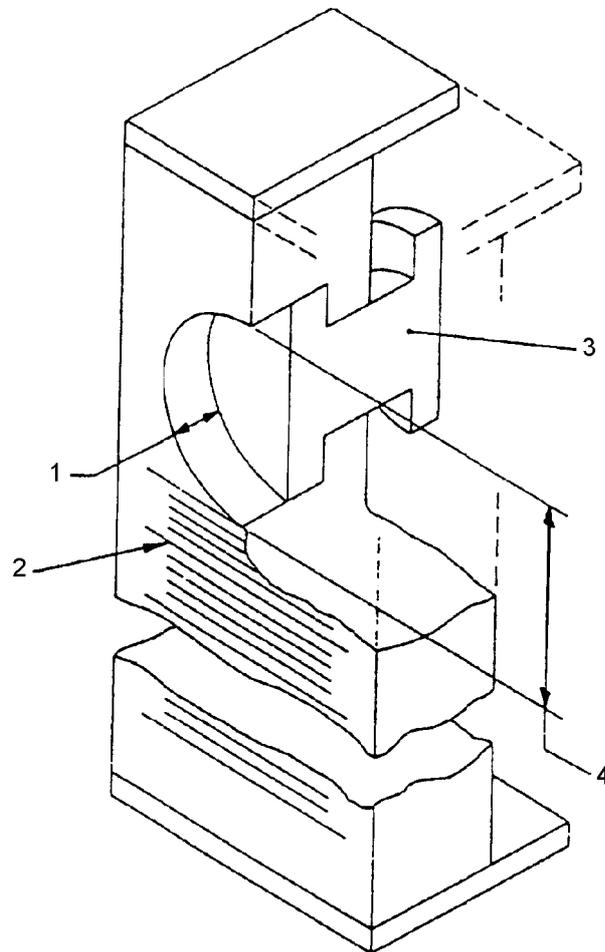

Key

- 1 Cavity depth $9,5 \pm 0,05$
- 2 Graduation
- 3 Plunger
- 4 Cavity diameter $38 \pm 0,05$

Figure 3 — Flow tester (Method 2: Use of a plug former)

8.3.2 Plastic scraper

8.3.3 Enclosure(s), to provide the specified test and conditioning atmosphere(s).

8.3.4 Solvent(s), suitable for cleaning the apparatus before and after use and for removal of excess adhesive.

8.4 Conditioning and pretreatment

Thoroughly clean the test apparatus with the solvent. Then condition it and the test adhesive for at least 5 h in the conditioning atmosphere.

NOTE If not otherwise specified the recommended conditions are (23 ± 2) °C and (50 ± 5) % RH.

8.5 Procedure

Place the test apparatus on a level surface with the drill face uppermost and depress the plunger until its face is 9,5 mm below the face of the block. Thoroughly mix or stir the adhesive, as appropriate, and fill the cavity, ensuring that no air pockets are formed. Level the adhesive flush with the face of the block with the scraper (8.3.2), drawing it across the filled cavity so that the excess adhesive is carried away from the graduated scale, i.e. the part of the face down which flow will subsequently occur.

Advance the plunger to the limit of its travel so that its face is level with the surface of the block thus leaving a test portion of adhesive in the form of a cylindrical plug, 38 mm in diameter, on the face of the block.

Taking care to avoid vibration immediately mount the apparatus vertically with the adhesive plug at the top (see Figure 4) and leave in the test atmosphere for the specified time.

Dimensions in millimetres

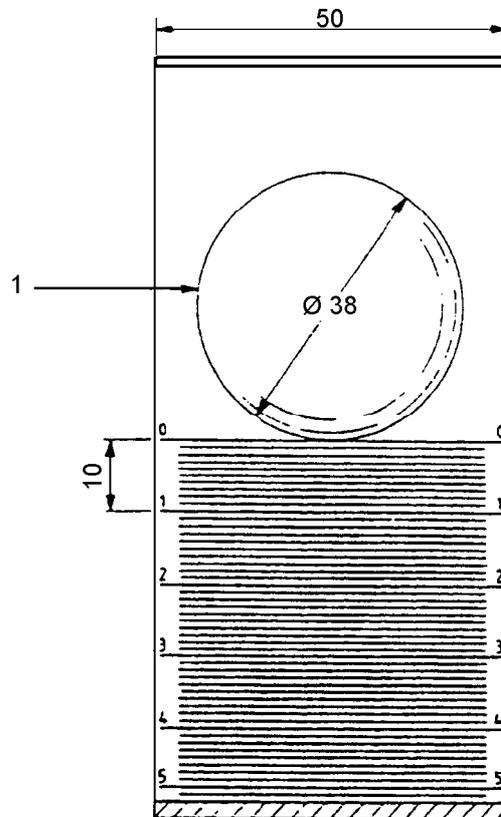
**Key**

- 1 Extruded adhesive plug

Figure 4 — Adhesive plug before testing (Method 2: Use of a plug former)

At the end of the test period, read to the nearest millimetre the lowest point of the adhesive flow (see Figure 5). Immediately clean the apparatus and repeat the test with a further test portion of adhesive. Carry out at least three tests.

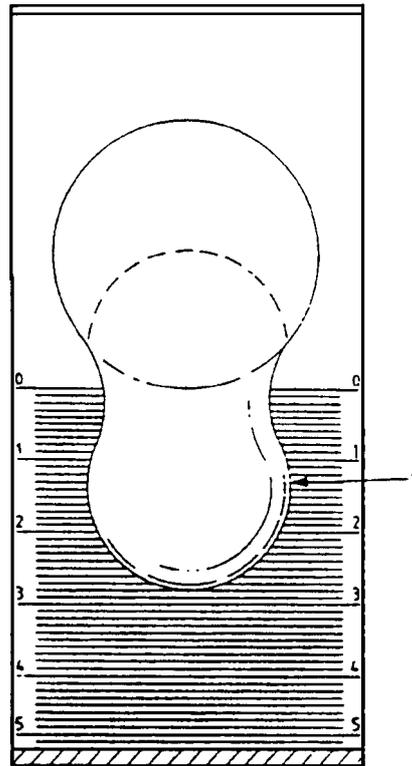

Key

- 1 Adhesive flow

Figure 5 — Adhesive plug after testing (Method 2: Use of a plug former)

8.6 Expression of results

Express the sagging as the mean of the distance in millimetres travelled by the adhesive for the repeated test results.

8.7 Test report

The report shall state the following:

- a) reference to this European Standard;
- b) all information necessary for the complete identification of the adhesive;
- c) items of supplementary information given in 8.2;
- d) result of each individual test and the mean;
- e) that the method of test complied with the requirements of this standard, i.e. Method 2, or if it did not, the respects in which it did not comply;
- f) any operating details not specified in the method, as well as any incidents likely to have affected the results, such as phase separation, etc.;
- g) date of the test.

9 Method 3: Use of a scraper

9.1 Principle

This method applies to sagging at room temperature or during curing and is recommended for quality control test purposes.

A wet film of adhesive of defined shape is applied to a flat horizontal surface of a substrate using a scraper. After application the panel is placed vertically at $(23 \pm 2) ^\circ\text{C}$ or in the test atmosphere for curing for a specified time.

The extent of sagging of the applied adhesive is measured.

9.2 Supplementary information

See Method 1, 7.2.

9.3 Apparatus and materials

9.3.1 Set of scrapers cut from $(1,62 \pm 0,05)$ mm thick aluminium sheet to the dimensions given in Figure 6.

9.3.2 Degreased flat aluminium plate of approximate dimensions 100 mm · 150 mm · 1,6 mm.

9.3.3 Circulating air oven (if required) to provide the specified conditioning and/or test atmospheres.

9.3.4 Ruler graduated in millimetres

Dimensions in millimetres

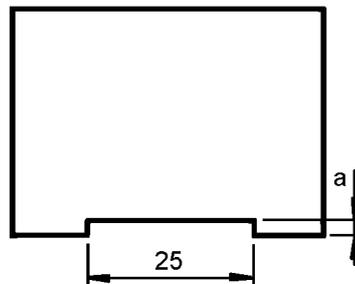

Key

Scraper:

1,6: $a = 1,6$

3,2: $a = 3,2$

4,8: $a = 4,8$

6,35: $a = 6,35$

Figure 6 — Scraper (Method 3: Use of a scraper)

9.4 Conditioning and pretreatment

Cut out test panels as required. Thoroughly clean each panel and then carry out any specified pretreatment. Condition the adhesive and the prepared test panels (if required) in the specified conditioning atmosphere.

NOTE If not otherwise specified the recommended conditions are (23 ± 2) °C and (50 ± 5) % RH.

9.5 Procedure

Select a scraper.

Place adhesive on the aluminium plate parallel to the 100 mm side so as to cover an approximate area of 38 mm · 75 mm with a depth greater than that of the scraper to be used.

Holding the scraper at an angle of 45°, draw the scraper slowly across the adhesive so as to deposit a uniform 25 mm · 75 mm, ribbon parallel to the 100 mm side of the aluminium plate.

NOTE Significant deviations from the 45° angle will change the film thickness and resultant sagging measurement.

Place the adhesive coated panel in a vertical position (with the adhesive ribbon horizontal) at either (23 ± 2) °C or in a circulating- air oven as specified. Materials to be tested in an oven shall be allowed to remain in the oven for 30 min. Materials to be tested at (23 ± 2) °C shall be allowed to remain at this temperature for the specified time.

At the end of the specified time, measure the width (W) of the adhesive ribbon.

Repeat the procedure with the other scrapers.

9.6 Expression of results

The measurement of sagging (S) shall be reported as the increase in ribbon width.

$$S = W - 25$$

where

S is the sagging in millimetres;

W is the adhesive ribbon width in millimetres.

9.7 Test report

The report shall state the following:

- a) reference to this European Standard;
- b) all information necessary for the complete identification of the adhesive;
- c) items of supplementary information given in 9.2;
- d) result for each scraper depth "a" (see Figure 6);
- e) that the method of test complied with the requirements of this standard; i.e. Method 3, or if it did not, the respects in which it did not comply;
- f) any operating details not specified in the method, as well as any incidents likely to have affected the results, such as phase separation, etc.;
- g) date of the test.

10 Method 4: Use of test blocks

10.1 Principle

This method characterizes the tendency to static flow of adhesives when applied (30 min test at ambient temperature) and when remaining in stoving ovens (duration and temperature as specified).

It applies particularly to heat curable adhesives.

The tendency of adhesives to flow is characterized by the displacement of a block of the sample placed on an inclined plane.

10.2 Apparatus and materials

10.2.1 Conditioned enclosure, stabilized at (23 ± 2) °C and (50 ± 5) % relative humidity.

10.2.2 Ventilated oven, temperature adjustable up to 250 °C and accurate to 2 °C.

10.2.3 Mounting, giving a slope of 60° in relation to the horizontal. Another slope may be used if specified.

10.2.4 Washers, from a film of polyethylene terephthalate, diameter 22 mm, thickness approximately 0,1 mm.

10.2.5 Equipment for preparing test blocks (see Figure 7).

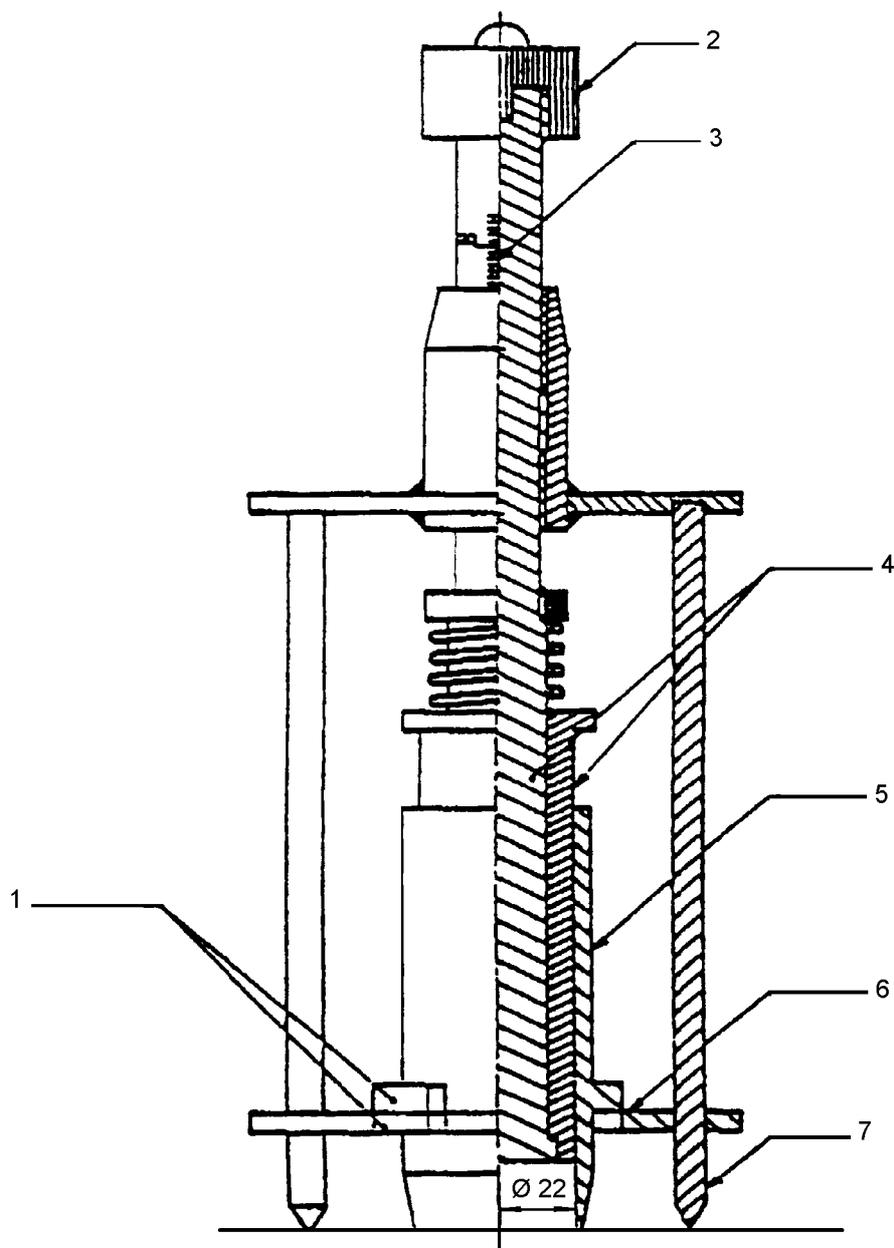

Key

- 1 Male and female lugs enabling stripping for cleaning
- 2 Knurled knob for adjusting height of block
- 3 Graduations in mm
- 4 Ejector piston assembly
- 5 Body of syringe
- 6 Lower platen
- 7 Tripod

Figure 7 — Device for preparing test blocks (Method 4: use of test blocks)

10.2.6 Ruler graduated in millimetres

10.2.7 Spatula

10.2.8 Test panels, 150 mm long and approximately 50 mm wide, as specified. For test panels made of steel sheet, in the absence of any other indication, use either a zinc electroplated steel sheet degreased and re-greased in accordance with EN 13887 or steel sheet coated with electrodeposited paint by the cationic method (for example, CORONA ED 3002 type) and stoved for 17 min at 200 °C.

10.3 Conditioning and pretreatment

Condition the product in the enclosure (10.2.1) for 16 h.

Procedure A: Homogenize the product, using the spatula (10.2.7), immediately before taking the test portion.

Procedure B: Take the product directly from the storage container.

NOTE 1 For products necessitating a mixture of several components, this is effected with a spatula for one minute and the test should be started 5 min after starting to mix.

NOTE 2 The choice of procedure A or B and of sampling conditions should be given in the manufacturer's technical data sheet.

10.4 Procedure

Carry out the test in the conditioned enclosure (10.2.1).

Adjust the graduation of the block-preparation device (10.2.5) to obtain the desired block thickness, usually 4 mm.

Turn the equipment upside down and place a washer (10.2.4) at the bottom of the cavity formed by the withdrawal of the piston.

Fill the cavity to the rim with the product to be tested taking care to keep the body of the syringe in contact with the lower platen.

In a period of time less than or equal to 15 min, place the equipment at one end of a test panel (10.2.8) located on a horizontal surface.

Raise the syringe body until it contacts the flange round the piston; raise it further in order to lift the piston slightly, so that the block is deposited onto the test panel.

Remove the equipment (10.2.5).

Mark the initial position of the edge of the block as shown in Figure 8.

(30 ± 2) s after depositing the block, place the test panel and block on the mounting (10.2.3) in the enclosure set at (23 ± 2) °C so that the block is on the sloping plane. Ensure that the mounting has already been brought to the temperature of the enclosure.

Leave the test panel and block in this position for 30 min.

Mark the new position of the edge of the block as shown in Figure 8.

Place the mounting, and the test panel and block in the oven (10.2.2) at the temperature and for the time specified.

Remove the test panel and block from the oven and mark the position of the edge of the block as shown in Figure 8.

Measure with the ruler (10.2.6) lengths L and L' (see Figure 8) in millimetres.

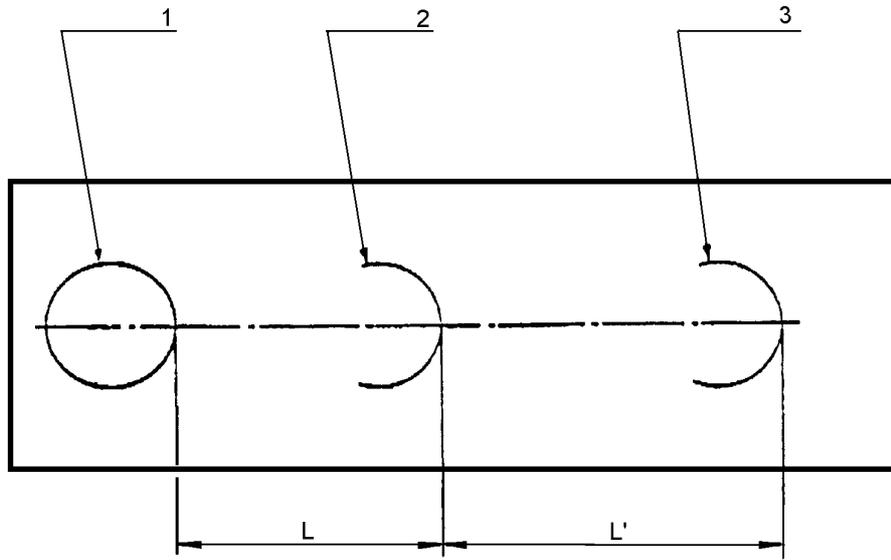

Flow without deformation of the block

8b

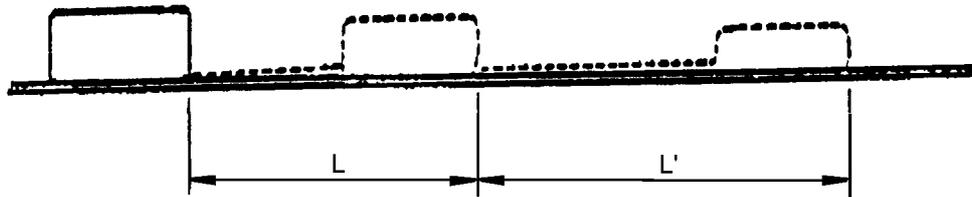

Flow with deformation of the block

8c

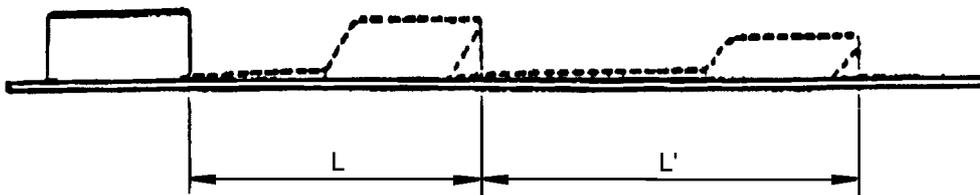

Key

- 1 Initial position of block
- 2 Position of block after test at ambient temperature
- 3 Position of block after test under stoving conditions

The marks shall be made outside the trajectory of the block.

Figure 8 — Marking of displacement of test blocks on test panel (Method 4: Use of test blocks)

10.5 Expression of results

The flow and/or sliding (displacement of the block without noticeable deformation) are characterized:

- . at ambient temperature by distance L in millimetres;
- . after stoving by distance L' in millimetres.

Whatever the form assumed by the block at the end of the different phases of the test, the distances are measured perpendicular to the top of the block (see Figure 8).

For fluid products with a flow rate exceeding 120 mm in 30 min, the time necessary to reach this limit shall be indicated.

10.6 Test report

The report shall state the following:

- a) reference to this European Standard;
- b) all information necessary for the complete identification of the adhesive;
- c) method of sampling the product (procedure A or B, see 10.3);
- d) thickness of the block (usually 4 mm);
- e) support used;
- f) slope, if this is different to 60° in relation to the horizontal;
- g) temperature and the stoving time;
- h) number of tests carried out;
- i) average displacement and the type of flow, i.e. flowing, sliding, mixed;
- j) that the method of test complied with the requirements of this standard, i.e. Method 4, or, if it did not, the respects in which it did not comply;
- k) any operating details not specified in the method, as well as any incidents likely to have affected the results, such as, for example, phase separation, etc;
- l) date of the test.

11 Method 5: Flow from a lap joint

11.1 Principle

The liquid adhesive fills an open slot between two panels of the test substrate. The test assembly is placed vertically in the test atmosphere for the specified time. Any flow from the slot is noted.

11.2 Supplementary information

This method of test requires that the following supplementary information shall be specified when this method is called up:

- a) description of the test substrate and its surface condition;
- b) thickness of the adhesive layer to be tested;
- c) details of the test atmosphere;
- d) details of the conditioning atmosphere;
- e) duration of the test.

11.3 Apparatus and materials

11.3.1 Panels, of the specified substrate and specified surface condition, measuring (50 · 100) mm and (50 · 25) mm.

11.3.2 Pairs of spacers, with approximate dimensions of (5 · 25) mm, of different thicknesses accurate to within 5 %, e.g. 0,5 mm, 1 mm, 1,5 mm, 2 mm, etc., to provide the specified thickness of adhesive layer in the test assembly.

11.3.3 Securing device, to hold the test assembly together.

11.3.4 Enclosure(s), to provide the specified conditioning and/or test atmosphere(s).

11.3.5 Plastic scraper

11.4 Conditioning

Condition the adhesive and the test panels in the specified conditioning atmosphere.

NOTE If not otherwise specified the recommended conditions are (23 ± 2) °C and (50 ± 5) % relative humidity.

11.5 Procedure

Take one large panel (11.3.1) and one small panel and a pair of spacers (11.3.2) of specified thickness and form a lap joint assembly as shown in Figure 9. Fill the slot between the two panels with adhesive, holding the assembly together with the securing device (11.3.3) if necessary. Lay the assembly on a horizontal surface with the smaller panel uppermost and level off the adhesive in the slot flush with the edges of the smaller panel using the scraper (11.3.5).

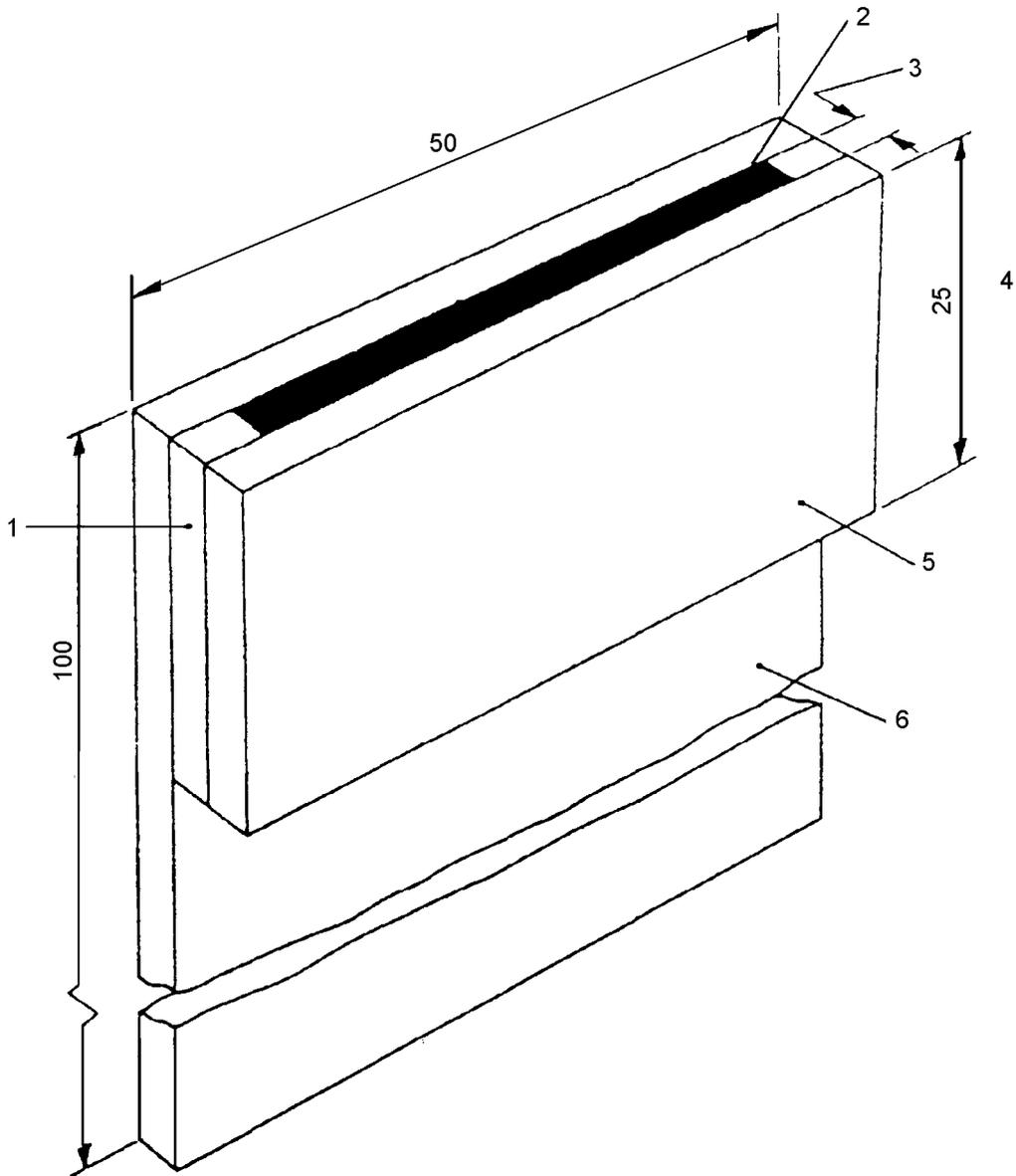

Key

- 1 Spacer
- 2 Adhesive
- 3 Thickness
- 4 Depth
- 5 Small panel
- 6 Large panel

Figure 9 — Test specimen for determining flow from lapped adhesive bond (Method 5: Flow from a lap joint)

Taking care to avoid vibration, immediately mount the assembly with the slot uppermost within 2° of the vertical and maintain it in this position in the test atmosphere for the specified time. At the end of the test period, examine the lower edge of the slot and note whether the adhesive has sagged below the plane of the lower slot edge.

11.6 Expression of results

Express the result as sagging or no sagging of the adhesive in the specified time, in the specified test atmosphere.

11.7 Test report

The report shall state the following:

- a) reference to this European Standard;
- b) all information necessary for the complete identification of the adhesive;
- c) items of supplementary information given in 11.2;
- d) result of the test;
- e) that the method of test complied with the requirements of this standard, i.e. Method 5, or if it did not, the respects in which it did not comply;
- f) any operating details not specified in the method, as well as any incidents likely to have affected the results, such as, for example, phase separation, etc;
- g) date of the test.

12 Method 6: Flow of adhesive through a hole

12.1 Principle

The liquid adhesive is placed to a specified depth in a shallow tray provided with holes of specified diameters. The tray is mounted in the test atmosphere for a specified time and the holes from which dripping of the adhesive occurs are noted.

12.2 Supplementary information

This method of test requires that the following supplementary information shall be specified when this method is called up:

- a) diameters of the holes to be used;
- b) details of the test atmosphere and conditioning period;
- c) duration of the test.

12.3 Apparatus and materials

12.3.1 Tray(s), of aluminium, e.g. dish or cap of stamped foil having a depth of at least 5 mm, provided with circular holes of different specified diameters e.g. 3 mm, 4 mm, 5 mm, etc.

12.3.2 Enclosure(s), to provide the specified test atmosphere.

12.4 Conditioning

Condition the adhesive in the test atmosphere for the specified time.

NOTE If not otherwise specified the recommended conditions are (23 ± 2) °C and (50 ± 5) % relative humidity.

12.5 Procedure

Clean the tray, place it on a flat surface and fill it to a depth of 5 mm with the adhesive.

Immediately raise the tray and support it in a horizontal position so that the holes are clear of the supporting surface by a distance of at least five times the diameter of the largest hole so that there is room for drops of adhesive to form and become detached.

Maintain the tray in the test atmosphere for the specified time. At the end of the test note for each hole whether dripping of adhesive has occurred.

12.6 Expression of results

Express the results as the diameter in millimetres of the largest hole through which there has been no dripping of the adhesive in the specified time in the specified atmosphere.

12.7 Test report

The report shall state the following:

- a) reference to this European Standard;
- b) all information necessary for the complete identification of the adhesive;
- c) items of supplementary information given in 12.2;
- d) result of the test;
- e) that the method of test complied with the requirements of this standard, i.e. Method 6 or, if it did not, the respects in which it did not comply;
- f) any operating details not specified in the method, as well as any incidents likely to have affected the results, such as, for example, phase separation, etc;
- g) date of the test.

13 Method 7: Flow of structural adhesive films

13.1 Principle

This method describes the determination of the flow behaviour of structural adhesives supplied in the form of adhesive films.

This test method is used:

- . for assessing the flow behaviour of adhesives;
- . for determining the alteration in flow behaviour due to adhesive storage time;
- . for determining environmentally-caused changes in flow behaviour.

A disc of adhesive film is compressed and cured under controlled conditions and the increase in surface area is measured.

13.2 Conditioning and pretreatment

13.2.1 Allow cold-stored adhesives to attain room temperature in their original packing. Cut test samples of diameter (38 ± 1) mm, out of the adhesive without removing the protective film.

13.2.2 Prepare at least three test samples for each test.

13.3 Apparatus

The apparatus consists of 2 level-ground pressure plates made of aluminium or steel fitted with drill-holes for temperature control purposes.

The pressure plates have markings ensuring that the samples can be laid centrally in the apparatus.

Select the thickness of the pressure plates in order to ensure a consistent pressure distribution in accordance with the curing system used. The area of the pressure plates is determined by the number of test samples to be tested simultaneously.

Allow an area of at least 100 cm^2 per test sample, with distance between the centres of adjacent test samples of at least 100 mm and a distance between the centre of a test sample and the edge of the pressure plate of at least 50 mm.

If the test is carried out on one test sample only, the spring-loaded test clamp may be used (see Figure 10).

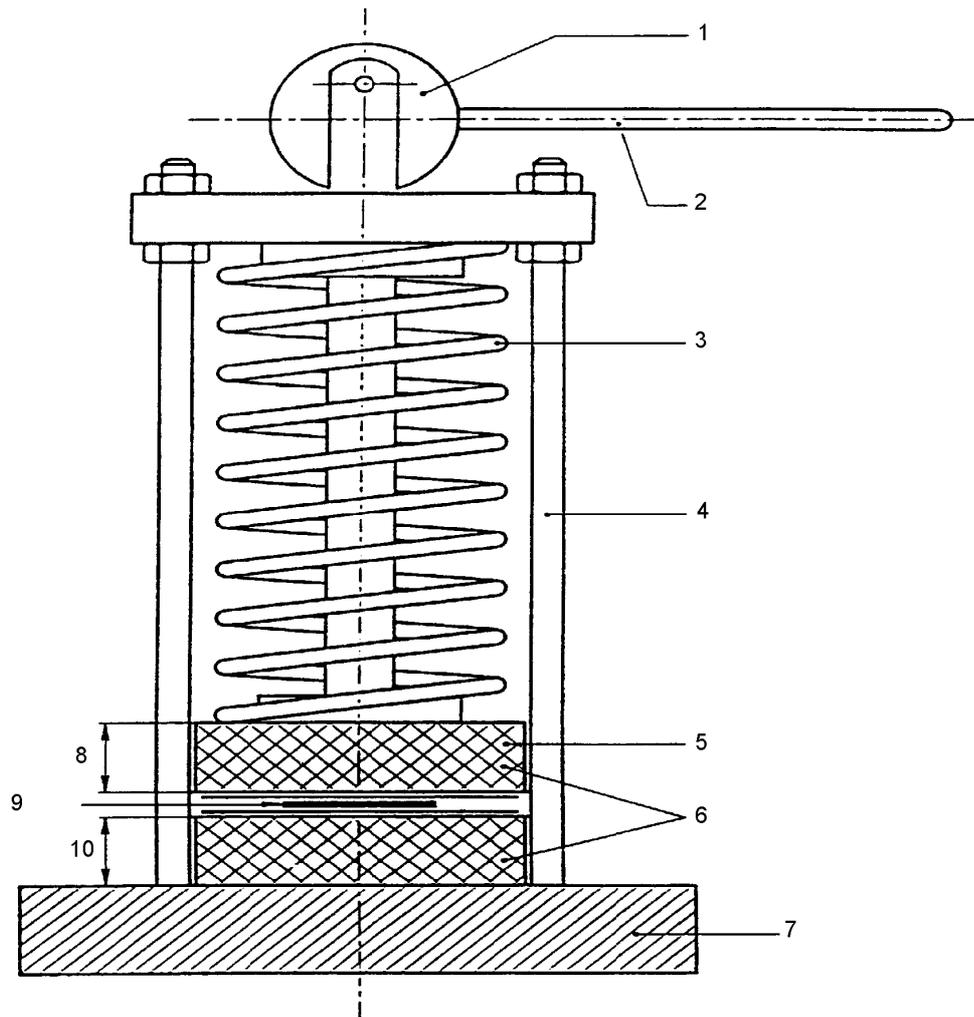

Key

- 1 Cam
- 2 Clamping and releasing lever
- 3 Pre-stressed spring (spring constant $c=20$ N/mm)
- 4 Guide rod
- 5 \varnothing 100 mm
- 6 Pressure plates with drill-holes for thermocouples
- 7 Base plate
- 8 30 mm
- 9 Test sample
- 10 30 mm

Figure 10 — Test device with a loaded spring (Method 7: Flow of structural adhesive films)

The following backing film may be used for the test:

- . polyethylene terephthalate foil 0,05 mm thick for test temperatures up to 140 °C.
- . polyvinylidene fluoride foil, 0,05 mm thick, for test temperatures over 140 °C.

NOTE In the case of comparative tests the type of backing film used can have an influence on the flow.

13.4 Procedure

Using a press or an autoclave or, in the case of a spring-loaded test clamp with the aid of an air-circulating oven, subject the test device and test samples to the curing cycle prescribed in the relevant material standard for the adhesive.

NOTE 1 The simultaneous testing of test samples having different flows can induce measuring errors due to interference between the test samples. An individual proof test using a spring-loaded test clamp should be carried out in arbitration cases.

The determination of the flow by means of an autoclave (pressure plates not guided in parallel) provides values which cannot be directly compared with those obtained by means of pressure plates guided in parallel (press, testing device in accordance with Figure 10).

Carry out the test in the case of cold-stored adhesives, within 8 h after reaching room temperature.

During the time between its removal of storage and its curing, the adhesive shall be maintained in a condition of humidity and temperature suitable to the material.

Measure the test sample diameter to an accuracy of 0,5 mm.

After removal of the protective film, lay the test sample between two backing films such that the central clearances, as given in 13.3, are obtained.

Arrange the test samples to ensure consistent pressure distribution on the backing film.

NOTE 2 In order to simplify the arrangement of the test samples on the backing film and the central locating of the backing films, markings can be made on the backing films. (Examples, see Figure 11).

Dimensions in millimetres

Example 1

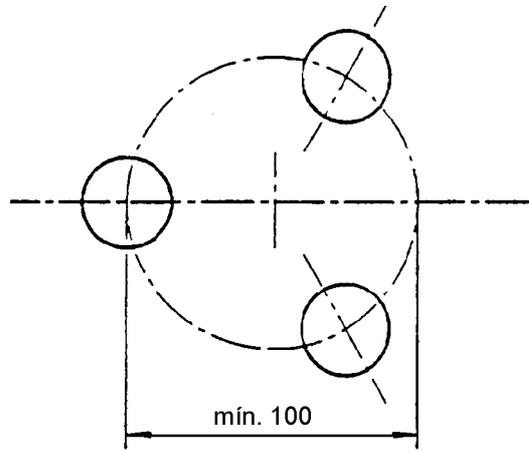

11 a

Example 2

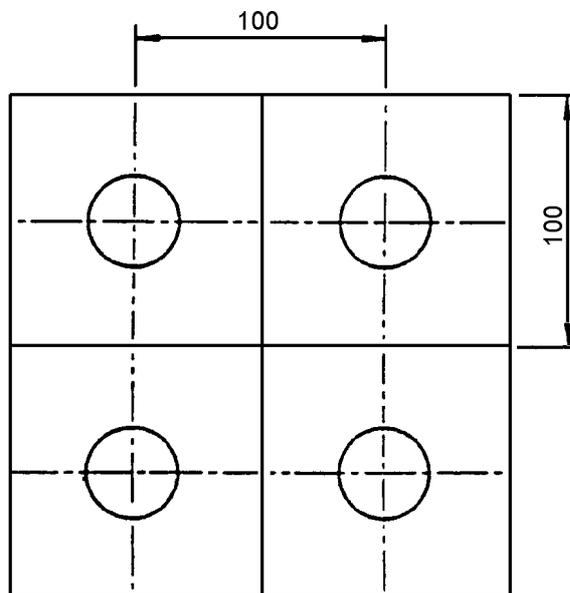

11 b

Figure 11 — Arrangement of test samples on backing film for storage in the test device (Method 7: Flow of structural adhesive films)

Carry out the flow test using the cure cycle given for the adhesive to be tested. Take the required data such as preheating, curing temperature and curing time from the relevant material standard.

Carry out the test with a pressure of 0,35 MPa unless otherwise specified in the material standard.

On completion of the curing cycle, remove the test samples together with the backing films from the test clamp and allow to cool to room temperature.

When the test samples have reached room temperature, measure the smallest and largest diameter of each test sample to an accuracy of 0,5 mm. Record the diameter d_2 as the mean value of the two measurements.

13.5 Calculation of flow

13.5.1 Calculation by diameter change

Use the following equation to calculate the flow (F) as a percentage:

$$F = \left(\frac{d_2^2}{d_1^2} - 1 \right) \cdot 100$$

where

d_1 = diameter of test sample before the test, in millimetres;

d_2 = diameter of the sample after the test, in millimetres.

13.5.2 Calculation of flow by area change during cure for bonding structural adhesive films

This calculation requires the following modified procedure.

13.5.3 Materials and apparatus:

- . Sections of polyethylene terephthalate film, 0,05 mm thick, of approximate dimensions 250 mm · 250 mm;
- . Sections of aluminium film, 0,025 mm thick, of approximate dimensions 250 mm · 250 mm;
- . Planimeter.

13.5.4 Procedure

Cut a sample from the centre and from either edge of the film using a (38 ± 1) mm diameter cutting die.

Weigh the sample to nearest 0,1 g and record the mass.

Cover the sample with aluminium foil on one side and polyethylene terephthalate on the other.

Cure the sample as specified in the manufacturer's technical data sheet or specification and determine the total area.

13.5.5 Calculation

Use the following equation to calculate the flow (F_1) in square millimetres per gram:

$$F_1 = \frac{A_t - A_o}{W_e - K}$$

where

- A_t = total area after cure in square millimetres;
- A_o = area of original specimen in square millimetres;
- w_e = mass of sample in grams;
- K = mass of carrier in grams.

Report the flow as the mean of the individual values for centre and edge specimens.

13.6 Test report

The test report shall contain the following information:

- a) reference to this European Standard;
- b) complete identification of adhesive including manufacturer's designation and date of manufacture, batch and roll numbers;
- c) curing cycle with information on temperature/time and pressure/time;
- d) adhesive storage life information (type, duration, temperature) before the test is carried out;
- e) date of manufacture of the samples;
- f) number of test samples;
- g) identification of the baking films used;
- h) description of the testing apparatus (material and dimensions of pressure plates, presses, autoclaves or the spring-load testing device);
- i) individual and mean values for flow factor in accordance with 13.5;
- j) that the method of test complied with the requirements of this standard, i.e. Method 7, or, if it did not, the respects in which it did not comply;
- k) any operating details not specified in the method, as well as any incidents likely to have affected the results, such as, for example, phase separation, etc;
- l) date of the test.

ICS 83.180

Price based on 26 pages