Graphical symbols for diagrams —
Part 8:
Valves and dampers

Symboles graphiques pour schémas —

Partie 8: Appareils de robinetterie et registres



Reference number
ISO 14617-8:2002(E)

© ISO 2002

PDF disclaimer

This PDF file may contain embedded typefaces. In accordance with Adobe's licensing policy, this file may be printed or viewed but shall not be edited unless the typefaces which are embedded are licensed to and installed on the computer performing the editing. In downloading this file, parties accept therein the responsibility of not infringing Adobe's licensing policy. The ISO Central Secretariat accepts no liability in this area.

Adobe is a trademark of Adobe Systems Incorporated.

Details of the software products used to create this PDF file can be found in the General Info relative to the file; the PDF-creation parameters were optimized for printing. Every care has been taken to ensure that the file is suitable for use by ISO member bodies. In the unlikely event that a problem relating to it is found, please inform the Central Secretariat at the address given below.

© ISO 2002

All rights reserved. Unless otherwise specified, no part of this publication may be reproduced or utilized in any form or by any means, electronic or mechanical, including photocopying and microfilm, without permission in writing from either ISO at the address below or ISO's member body in the country of the requester.

ISO copyright office
Case postale 56 • CH-1211 Geneva 20
Tel. + 41 22 749 01 11
Fax + 41 22 749 09 47
E-mail copyright@iso.ch
Web www.iso.ch

Printed in Switzerland

Contents

Page

Foreword	iv
Introduction.....	v
1 Scope.....	1
2 Normative references.....	1
3 Terms and definitions	1
4 General-purpose valves.....	3
5 Dampers	9
6 Valves for fluid power systems	10
7 Hygienic valves	20
8 Valves with special functions	21
Bibliography.....	23

Foreword

ISO (the International Organization for Standardization) is a worldwide federation of national standards bodies (ISO member bodies). The work of preparing International Standards is normally carried out through ISO technical committees. Each member body interested in a subject for which a technical committee has been established has the right to be represented on that committee. International organizations, governmental and non-governmental, in liaison with ISO, also take part in the work. ISO collaborates closely with the International Electrotechnical Commission (IEC) on all matters of electrotechnical standardization.

International Standards are drafted in accordance with the rules given in the ISO/IEC Directives, Part 3.

The main task of technical committees is to prepare International Standards. Draft International Standards adopted by the technical committees are circulated to the member bodies for voting. Publication as an International Standard requires approval by at least 75 % of the member bodies casting a vote.

Attention is drawn to the possibility that some of the elements of this part of ISO 14617 may be the subject of patent rights. ISO shall not be held responsible for identifying any or all such patent rights.

ISO 14617-8 was prepared by Technical Committee ISO/TC 10, *Technical product documentation*, Subcommittee SC 10, *Process plant documentation and tpd-symbols*.

ISO 14617 consists of the following parts, under the general title *Graphical symbols for diagrams*:

- *Part 1: General information and indexes*
- *Part 2: Symbols having general application*
- *Part 3: Connections and related devices*
- *Part 4: Actuators and related devices*
- *Part 5: Measurement and control devices*
- *Part 6: Measurement and control functions*
- *Part 7: Basic mechanical components*
- *Part 8: Valves and dampers*
- *Part 9: Pumps, compressors and fans*
- *Part 10: Fluid power converters*
- *Part 11: Devices for heat transfer and heat engines*
- *Part 12: Devices for separating, purification and mixing*
- *Part 15: Installation diagrams and network maps*

Other parts are under preparation.

Introduction

The purpose of ISO 14617 in its final form is the creation of a library of harmonized graphical symbols for diagrams used in technical applications. This work has been, and will be, performed in close cooperation between ISO and IEC. The ultimate result is intended to be published as a standard common to ISO and IEC, which their technical committees responsible for specific application fields can use in preparing International Standards and manuals.

1
2
3
4
5
6
7
8
9
10
11
12
13
14
15
16
17
18
19
20
21
22
23
24
25
26
27
28
29
30
31
32
33
34
35
36
37
38
39
40
41
42
43
44
45
46
47
48
49
50
51
52
53
54
55
56
57
58
59
60
61
62
63
64
65
66
67
68
69
70
71
72
73
74
75
76
77
78
79
80
81
82
83
84
85
86
87
88
89
90
91
92
93
94
95
96
97
98
99
100

Graphical symbols for diagrams —

Part 8: Valves and dampers

1 Scope

This part of ISO 14617 specifies graphical symbols for valves and dampers in diagrams, including symbols for general-purpose valves, those used in fluid power systems and hygienic valves used in the food and pharmaceutical industries.

For the fundamental rules of creation and application of graphical symbols in diagrams, see ISO 81714-1.

For an overview of ISO 14617, information on the creation and use of registration numbers for identifying graphical symbols used in diagrams, rules for the presentation and application of these symbols, and examples of their use and application, see ISO 14617-1.

2 Normative references

The following normative documents contain provisions which, through reference in this text, constitute provisions of this part of ISO 14617. For dated references, subsequent amendments to, or revisions of, any of these publications do not apply. However, parties to agreements based on this part of ISO 14617 are encouraged to investigate the possibility of applying the most recent editions of the normative documents indicated below. For undated references, the latest edition of the normative document referred to applies. Members of ISO and IEC maintain registers of currently valid International Standards.

ISO 14617-1:2002, *Graphical symbols for diagrams — Part 1: General information and indexes*

ISO 14617-2:2002, *Graphical symbols for diagrams — Part 2: Symbols having general application*

ISO 14617-4:2002, *Graphical symbols for diagrams — Part 4: Actuators and related devices*

ISO 81714-1:1999, *Design of graphical symbols for use in the technical documentation of products — Part 1: Basic rules*

3 Terms and definitions

For the purposes of this part of ISO 14617, the following terms and definitions apply.

NOTE The list has been restricted to terms whose meaning is not obvious and which have not been defined elsewhere in an International Standard, or which have been defined in various ways in different standards. In preparing these definitions, ISO and IEC standards on terminology have been consulted; see the references in parentheses. However, most of the definitions in those standards were prepared by different technical committees within a restricted scope. This means that many terms so defined have to be given more general or neutral definitions when applied in the context of graphical symbols.

3.1

safety valve

valve which automatically, without the assistance of any energy other than that of the fluid concerned, discharges a certified quantity of the fluid so as to prevent a predetermined safe pressure being exceeded, and which is designed to reclose and prevent the further flow of fluid after normal pressure conditions of service have been restored

[ISO 4126-1]

3.2

vacuum valve

valve which automatically and without the assistance of any energy other than that of the gas concerned, admits gas to a pipeline or tank in order to prevent a predetermined safe underpressure being exceeded

3.3

control valve

power-operated valve in an industrial-process control system for changing the flow rate of the process fluid

[IEC 60050-351]

3.4

restrictor

device which restricts the flow of a fluid thereby creating a pressure drop

[ISO 5598]

3.5

restrictor valve

valve in which the inlet and outlet ports are interconnected through a restricted passageway

NOTE In a fixed restrictor valve, the cross-sectional area cannot be altered; in an adjustable restrictor valve, the cross-sectional area can be adjusted.

3.6

release valve

valve through which non-desired air or steam in a pipe system may be released

3.7

pressure-reducing valve

pressure regulator

valve in which, with varying inlet pressure or outlet flow, the outlet pressure remains substantially constant, but in which the inlet pressure remains higher than the selected outlet pressure

3.8

pressure-relief valve

valve which limits maximum pressure by exhausting fluid when the required pressure is reached

3.9



exhaust valve

valve in which the outlet is automatically opened to exhaust when the air pressure falls at the inlet

4 General-purpose valves

4.1 Symbols of a basic nature

NOTE For general application rules, see R2101 (4.2.1).

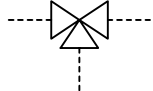
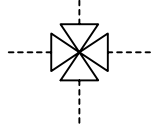
4.1.1	2101		Two-way valve See R2102 (4.2.2).
4.1.2	2102		Angled two-way valve See R2103 (4.2.3).
4.1.3	2103		Three-way valve
4.1.4	2104		Four-way valve

4.2 Application rules for the symbols in 4.1

4.2.1	R2101	Symbols for actuators and devices for delaying, automatic return, detaining, latching and blocking shall be chosen from ISO 14617-4. The imaginary direction of movement of the link between the symbol for a valve and that of the actuator or actuating function shall be — towards the valve: valve closing, and — from the valve: valve opening, independent of construction.
4.2.2	R2102	The symbol may be used as a symbol for a two-way valve in general or, in those installation diagrams where it is necessary to indicate whether a valve is straight or angled, as a symbol for a straight valve.
4.2.3	R2103	The symbol shall be used only when it is necessary to indicate the angled construction, for example, in certain installation diagrams.

4.3 Symbols giving supplementary information



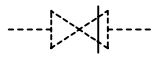

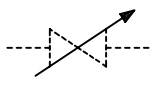
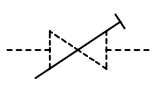
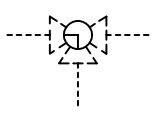
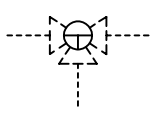
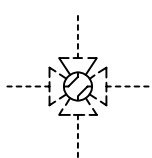
4.3.1 Functions

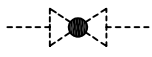
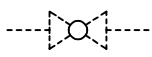

4.3.1.1	2111		Non-return function; check function Flow from left to right possible.
4.3.1.2	2112		Safety function Inlet or internal side to the left.

4.3.1.3	201		Adjustability See R201 (4.4.1).
4.3.1.4	203		Pre-set adjustability See R201 (4.4.1).
4.3.1.5	171	* >	Change of state when characteristic quantity passes set value from below, for example, in a safety valve or a pilot switch See R115 (4.4.2) and R121 (2-4.4.10).
4.3.1.6	172	* <	Change of state when characteristic quantity passes set value from above, for example, in a vacuum valve or pilot switch See R115 (4.4.2) and R122 (2-4.4.11).
4.3.1.7	2113		L-bore in a three- or four-way valve
4.3.1.8	2114		T-bore in a three- or four-way valve
4.3.1.9	2115		Double L-bore in a four-way valve

4.3.2 Construction

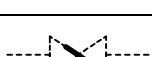
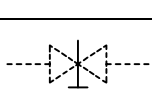
NOTE For the use of the symbols, see R2121 (4.4.3).

4.3.2.1	2121		Globe type
4.3.2.2	2122		Ball type
4.3.2.3	2123		Plug type
4.3.2.4	2124		Gate type
4.3.2.5	2125		Needle type
4.3.2.6	2126		Disc or butterfly type
4.3.2.7	2127		Piston type; plunger type

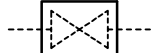
4.3.2.8	2128		Diaphragm type
4.3.2.9	2129		Hose type
4.3.2.10	2130		Reduced bore
4.3.2.11	2131		Jacket

4.4 Application rules for the symbols in 4.3

4.4.1	R201	The symbol should cross the centre of the symbol to which it is added. For examples, see X201 (2-5.5.1) to X206 (2-5.5.6), X2131 (4.5.4.1) and X2141 (4.5.5.1). If the symbol consists of an outline in the form of a square, rectangle or circle and a symbol inside indicating the function, another location could be more appropriate. For an example, see X207 (2-5.5.7).
4.4.2	R115	The asterisk shall be replaced with the letter symbol for the quantity or else shall be omitted. For examples, see X2121 (4.5.3.1) to X2125 (4.5.3.5).
4.4.3	R2121	The symbols shall be used only when it is necessary to show the construction.

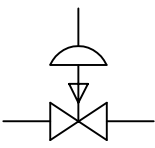
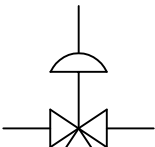
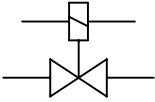

4.5 Application examples

4.5.1 Shut-off valves

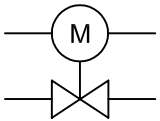
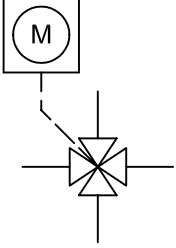
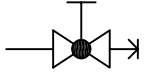
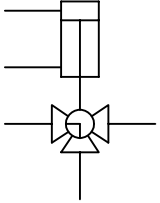
4.5.1.1	X2101	 403, 654, 725, 2101	Two-way valve with diaphragm actuator, opening when actuated and returning automatically to closed position at cessation of actuation
4.5.1.2	X2102	 403, 725, 2103	Three-way valve with diaphragm actuator
4.5.1.3	X2103	 403, 2101, IEC	Two-way valve with solenoid actuator

4.5.1.4	X2104	 <p>403, 2101, IEC</p>	Two-way valve with electric motor actuator
4.5.1.5	X2105	 <p>404, 741, 2104, IEC</p>	Four-way valve with actuating device of electric-motor type
4.5.1.6	X2106	 <p>403, 405, 565, 681, 2101, 2121</p>	Globe-type two-way valve with quick-release coupling, for example, for fire hydrant
4.5.1.7	X2107	 <p>403, 2103, 2113, 2442</p>	Ball-type three-way valve with double-acting fluid cylinder actuator

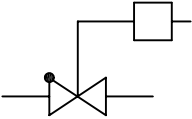
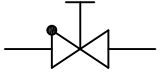
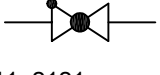
4.5.2 Non-return valves and check valves

4.5.2.1	X2111	 <p>403, 2001, 2101, 2111</p>	Weight-loaded non-return valve
4.5.2.2	X2112	 <p>403, 681, 2101, 2111</p>	Combined non-return valve and manually actuated stop valve
4.5.2.3	X2113	 <p>2101, 2111, 2121</p>	Globe-type non-return valve; lift-type non-return valve
4.5.2.4	X2114	 <p>2101, 2111, 2126</p>	Swing-type non-return valve

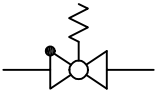
4.5.2.5	X2115	 403, 2002, 2101, 2122	Spring-loaded ball-type non-return valve
---------	-------	--	--

4.5.3 Valves with safety function

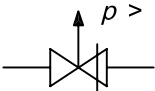
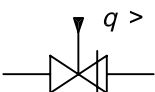
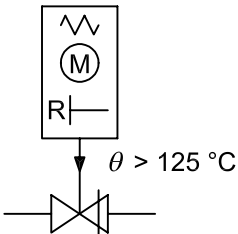
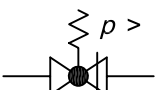
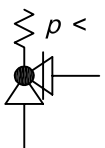
4.5.3.1	X2121	 171, 242, 403, 2101, 2112	Safety valve which opens when pressure p higher than set value
4.5.3.2	X2122	 171, 242, 403, 2101, 2112	Pipe break valve which closes when flow rate q is higher than set value
4.5.3.3	X2123	 171, 242, 403, 681, 741, 2002, 2101, 2112, IEC	Quick-acting valve which closes by spring actuator when temperature θ higher than 125 °C, with manual reset The spring is charged by an electric motor.
4.5.3.4	X2124	 171, 403, 2002, 2101, 2112, 2121	Globe type spring-loaded safety valve operating when pressure p higher than set value
4.5.3.5	X2125	 172, 403, 2002, 2102, 2112, 2121	Angled, globe-type, spring-loaded vacuum valve operating when pressure p lower than set value

4.5.4 Control valves

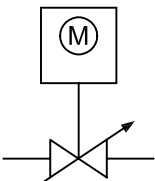
4.5.4.1	X2131	 201, 403, 741, 2101, IEC	Control valve with actuating device of electric motor type
---------	-------	---	--

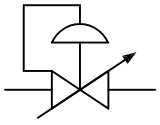
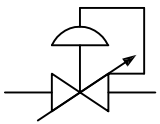
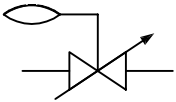
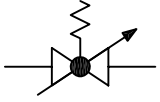
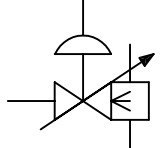
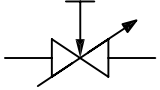
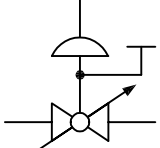
<p>4.5.4.2</p>	<p>X2132</p>	 <p>201, 403, 405, 725, 2101</p>	<p>Self-operating back-pressure control valve</p> <p>NOTE Flow from left to right is assumed.</p>
<p>4.5.4.3</p>	<p>X2133</p>	 <p>201, 403, 405, 725, 2101</p>	<p>Self-operating pressure reducing control valve</p> <p>NOTE Flow from left to right is assumed.</p>
<p>4.5.4.4</p>	<p>X2134</p>	 <p>201, 403, 715, 2101</p>	<p>Float-operated control valve</p>
<p>4.5.4.5</p>	<p>X2135</p>	 <p>201, 403, 2002, 2101, 2121</p>	<p>Spring-loaded globe-type relief valve</p>
<p>4.5.4.6</p>	<p>X2136</p>	 <p>201, 301, 403, 725, 2037, 2101</p>	<p>Diaphragm-operated de-superheater control valve</p>
<p>4.5.4.7</p>	<p>X2137</p>	 <p>201, 403, 681, 2101, 2125</p>	<p>Manually operated needle-type control valve</p>
<p>4.5.4.8</p>	<p>X2138</p>	 <p>201, 403, 501, 681, 725, 2101, 2122</p>	<p>Ball-type control valve, operated by diaphragm actuator or manual actuator</p>

4.5.5 Other valves

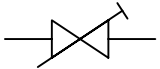
<p>4.5.5.1</p>	<p>X2141</p>	 <p>203, 2101</p>	<p>Restrictor valve</p>
----------------	--------------	--	-------------------------

5 Dampers

5.1 Symbols of a basic nature

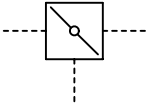
5.1.1	2151		Two- or three-way damper See R2101 (4.2.1).
-------	------	---	--

5.2 Application rules for the symbols in 5.1

See R2101 (4.2.1).

5.3 Symbols giving supplementary information

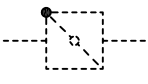
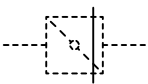
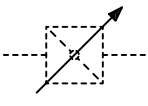
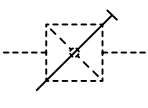
5.3.1	2111		Non-return function; check function Flow from left to right possible.
5.3.2	2112		Safety function Inlet is to the left.
5.3.3	201		Adjustability See R201 (4.4.1).
5.3.4	203		Pre-set adjustability See R201 (4.4.1).

5.4 Application rules for the symbols in 5.3

See 4.4.

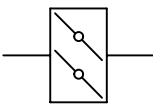
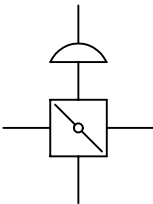

5.5 Application examples

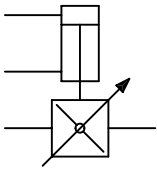
5.5.1	X2151	 <p data-bbox="400 1644 456 1671">2151</p>	Multi-leaf damper
5.5.2	X2152	 <p data-bbox="400 1928 564 1955">403, 725, 2151</p>	Three-way damper with diaphragm actuator

<p>5.5.3</p>	<p>X2153</p>	 <p>201, 403, 724, 2151</p>	<p>Control damper with double-acting fluid cylinder</p>
--------------	--------------	--	---

6 Valves for fluid power systems





6.1 Symbols of a basic nature



<p>6.1.1</p>	<p>2161</p>		<p>Valve See R2161 (6.2.1) and R2162 (6.2.2).</p>
<p>6.1.2</p>	<p>2162</p>		<p>Seat of a non-return valve</p>
<p>6.1.3</p>	<p>2163</p>		<p>Moving part of a non-return valve</p>

6.2 Application rules for the symbols in 6.1

<p>6.2.1</p>	<p>R2161</p>	<p>Symbols for actuators and devices for delaying, automatic return, detaining, latching and blocking shall be chosen from ISO 14617-4.</p>
<p>6.2.2</p>	<p>R2162</p>	<p>The symbol shall be divided into a number of equal rectangles, one for each distinctive valve position. In each rectangle, the asterisk shall be replaced with symbols for the flow paths. However, for certain valves, a simplified representation with only one rectangle may be used. See symbol 2175 (6.3.5) and R2172 (6.4.2).</p>

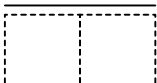
6.3 Symbols giving supplementary information

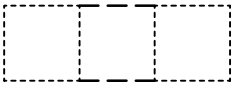
<p>6.3.1</p>	<p>2171</p>		<p>Open flow path See R2171 (6.4.1).</p>
<p>6.3.2</p>	<p>2172</p>		<p>Closed flow path</p>
<p>6.3.3</p>	<p>2173</p>		<p>Closed flow path of a leak-free valve</p>
<p>6.3.4</p>	<p>2174</p>		<p>Flow to open air</p>
<p>6.3.5</p>	<p>2175</p>		<p>Infinite number of intermediate positions of a valve See R2172 (6.4.2).</p>

6.3.6	2176		Transitory position See R2173 (6.4.3).
6.3.7	2177		Affected area See R2174 (6.4.4).

6.4 Application rules for the symbols in 6.3

6.4.1	R2171	When applicable, the symbol shall be supplemented with an indication of the actual flow direction. See the application examples in 6.5.	
6.4.2	R2172	For a valve with two distinct positions and an infinite number of intermediate positions a simplified representation is permitted implying that the symbol is omitted and only one rectangle drawn. For an example, see X2192 (6.5.2.2).	
6.4.3	R2173	The symbol for a transitory position shall be shown only when the flow paths in this position are necessary for the function of the circuit.	
6.4.4	R2174	The symbol for the affected area shall be used when it is necessary to show that two or more fluid circuits affect a valve on different areas. The width of the symbols shall correspond approximately to the different areas. For an example, see X2165 (6.5.1.5). Instead, the different areas may be indicated by symbols having the same width supplemented with numerical values.	

6.5 Application examples

6.5.1 Directional control valves

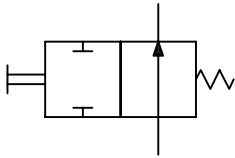
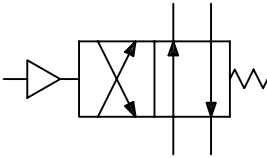
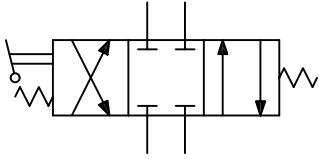
6.5.1.1	X2161	 <p>242, 402, 681, 2002, 2161, 2171, 2172</p>	Manually operated directional control valve with spring return to resting position
6.5.1.2	X2162	 <p>242, 244, 2002, 2161, 2171</p>	Direct, pneumatically operated directional control valve with spring return to resting position
6.5.1.3	X2163	 <p>242, 402, 688, 2002, 2161, 2171, 2172</p>	Lever-operated directional control valve with three positions and spring return to resting position (mid-position)

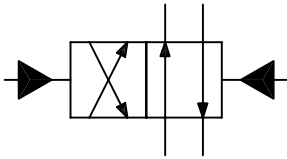
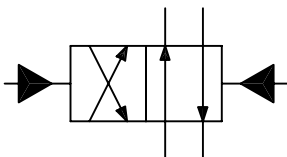
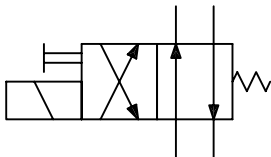
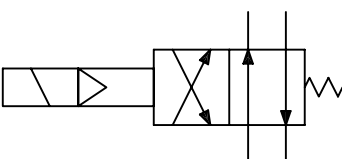
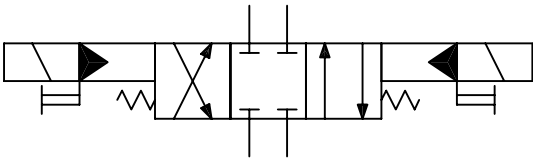
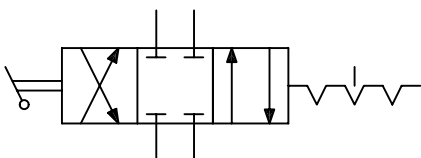
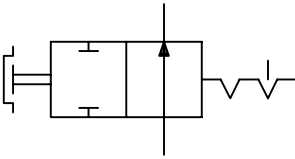
<p>6.5.1.4</p>	<p>X2164</p>	 <p>242, 243, 2161, 2171</p>	<p>Direct, hydraulically operated directional control valve</p>
<p>6.5.1.5</p>	<p>X2165</p>	 <p>242, 243, 2161, 2171, 2177</p>	<p>Direct, hydraulically operated directional control valve</p> <p>Different affecting areas are indicated.</p>
<p>6.5.1.6</p>	<p>X2166</p>	 <p>242, 402, 681, 2002, 2161, 2171, IEC</p>	<p>Manually or electrically operated directional control valve with spring return</p>
<p>6.5.1.7</p>	<p>X2167</p>	 <p>242, 718, 2002, 2161, 2171, IEC</p>	<p>Electropneumatically operated directional control valve with spring return</p>
<p>6.5.1.8</p>	<p>X2168</p>	 <p>242, 402, 681, 717, 2002, 2161, 2171, 2172, IEC</p>	<p>Electrohydraulically or manually operated directional control valve with spring return to resting position (mid-position)</p>
<p>6.5.1.9</p>	<p>X2169</p>	 <p>242, 402, 656, 657, 688, 2161, 2171, 2172</p>	<p>Lever-operated directional control valve, detained in all three positions</p>
<p>6.5.1.10</p>	<p>X2170</p>	 <p>242, 402, 656, 657, 681, 692, 2161, 2171, 2172</p>	<p>Manually operated directional control valve, detained in both positions with restricted access to actuator</p>

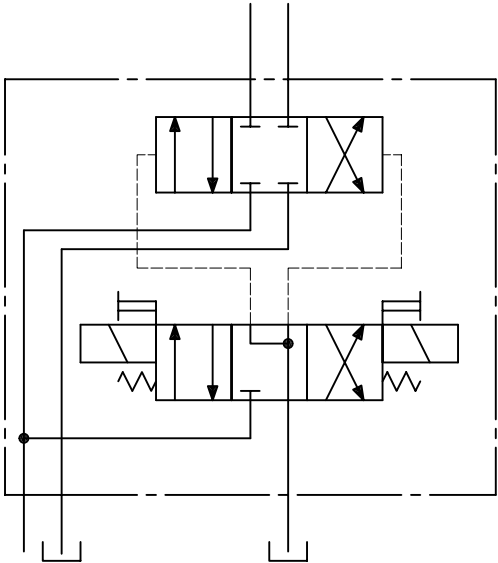
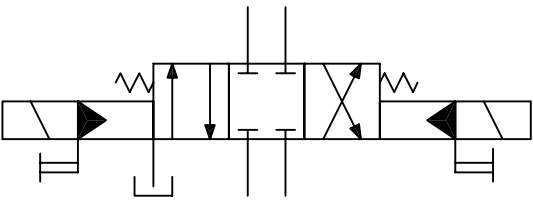
<p>6.5.1.11</p>	<p>X2171</p>	 <p>242, 243, 402, 405, 422, 501, 681, 2002, 2061, 2161, 2171, 2172, IEC</p>	<p>Directional control valve with pilot valve: main valve having three positions, actuated by internal pilot pressure, with spring return to mid-position; pilot valve having three positions, actuated electrically or manually, with spring return to mid-position</p> <p>Detailed and simplified forms shown.</p>
<p>6.5.1.12</p>	<p>X2172</p>	 <p>242, 243, 402, 681, 717, 2002, 2061, 2161, 2171, 2172, IEC</p>	

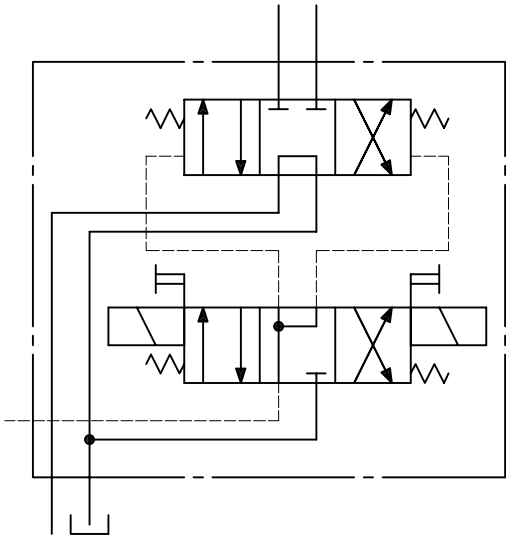
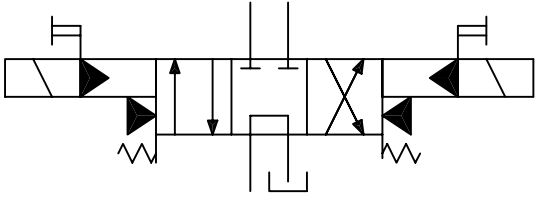
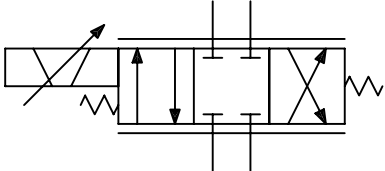
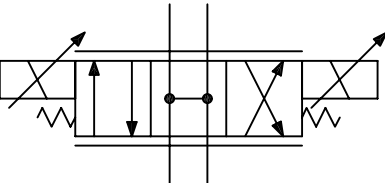
<p>6.5.1.13</p>	<p>X2173</p>	 <p>242, 402, 405, 422, 501, 681, 2002, 2061, 2161, 2171, 2172, IEC</p>	<p>Directional control valve with pilot valve: main valve having three positions, actuated by internal pilot pressure, with spring return to mid-position controlled by release of pilot pressure; pilot valve with three positions, actuated electrically or manually, with spring return to mid-position</p> <p>Detailed and simplified forms shown.</p>
<p>6.5.1.14</p>	<p>X2174</p>	 <p>242, 243, 402, 681, 717, 2002, 2061, 2161, 2171, 2172, IEC</p>	
<p>6.5.1.15</p>	<p>X2175</p>	 <p>201, 242, 2002, 2161, 2171, 2172, 2175, IEC</p>	<p>Directional servo-control valve with positive overlapping in mid-position, operated by double-acting solenoid, spring return to mid-position</p>
<p>6.5.1.16</p>	<p>X2176</p>	 <p>201, 242, 501, 2002, 2161, 2171, 2175, IEC</p>	<p>Directional servo-control valve with negative overlapping in mid-position, operated by two counter-acting solenoids, spring return to mid-position</p>

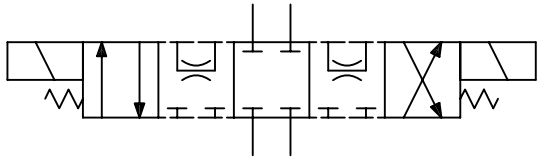
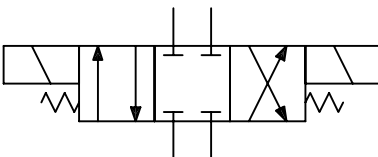
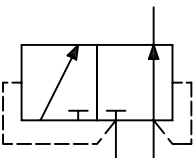
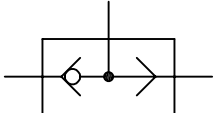
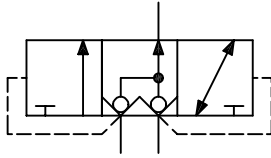
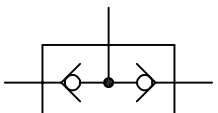
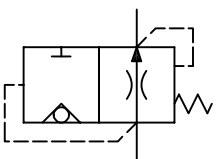

<p>6.5.1.17</p>	<p>X2177</p>	 <p>242, 2002, 2031, 2161, 2171, 2172, IEC</p>	<p>Electrically operated directional control valve</p> <p>Detailed and simplified forms shown. In the detailed form, the transitory positions shown.</p>
<p>6.5.1.18</p>	<p>X2178</p>	 <p>242, 2002, 2161, 2171, 2172, IEC</p>	
<p>6.5.1.19</p>	<p>X2179</p>	 <p>242, 422, 2161, 2171, 2172</p>	<p>Directional control valve with three ports and two positions</p> <p>EXAMPLE Shuttle valve with OR-function.</p> <p>The inlet port connected to the higher pressure is automatically connected to the outlet port while the other inlet port is closed.</p>
<p>6.5.1.20</p>	<p>X2180</p>	 <p>501, 2161, 2162, 2163, 2171</p>	<p>Detailed and simplified forms shown.</p>
<p>6.5.1.21</p>	<p>X2181</p>	 <p>242, 246, 405, 422, 501, 561, 2161, 2171, 2172, 2173</p>	<p>Directional control valve with three ports and three positions</p> <p>EXAMPLE Shuttle valve with AND-function.</p> <p>The outlet port is only under pressure if both inlet ports are under pressure.</p>
<p>6.5.1.22</p>	<p>X2182</p>	 <p>501, 2161, 2162, 2163, 2171</p>	<p>Detailed and simplified forms shown.</p>
<p>6.5.1.23</p>	<p>X2183</p>	 <p>242, 422, 2002, 2031, 2161, 2171, 2172, 2173</p>	<p>Directional leak-free control valve with two ports and two positions</p> <p>EXAMPLE Pipe break valve.</p>

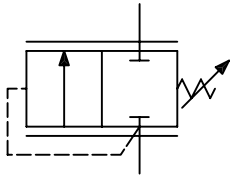
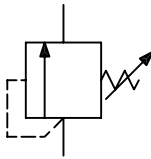
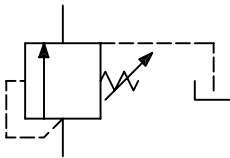
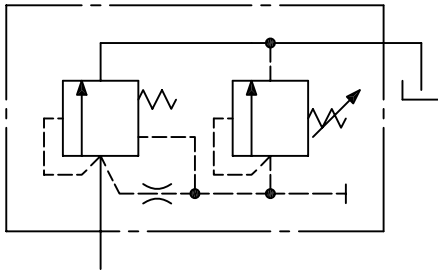
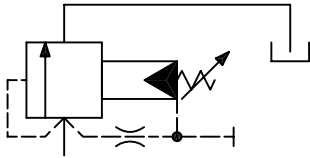
6.5.2 Pressure control valves

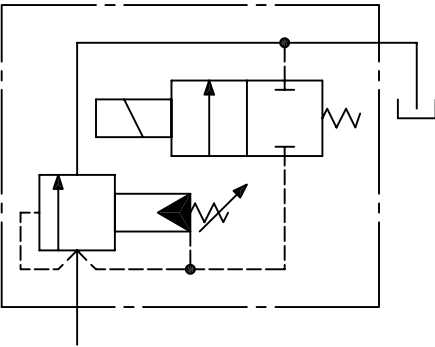
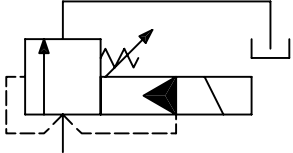
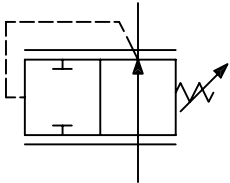
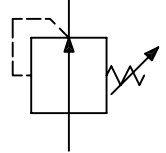
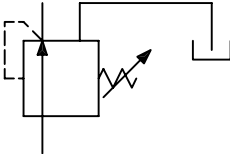
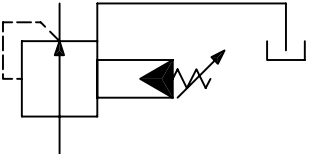
<p>6.5.2.1</p>	<p>X2191</p>	 <p>201, 242, 422, 2002, 2161, 2171, 2172, 2175</p>	<p>Single-stage pressure-relief valve Detailed and simplified forms shown.</p>
<p>6.5.2.2</p>	<p>X2192</p>	 <p>201, 242, 422, 2002, 2161, 2171</p>	
<p>6.5.2.3</p>	<p>X2193</p>	 <p>201, 242, 405, 422, 2002, 2061, 2161, 2171</p>	<p>Single-stage pressure-relief valve with external drain, for use, for example, as sequence valve</p>
<p>6.5.2.4</p>	<p>X2194</p>	 <p>201, 242, 405, 422, 501, 503, 2002, 2031, 2061, 2161, 2171</p>	<p>Two-stage pressure-relief valve with provision for remote control Detailed and simplified forms shown.</p>
<p>6.5.2.5</p>	<p>X2195</p>	 <p>201, 242, 405, 422, 501, 503, 717, 2002, 2031, 2061, 2161, 2171</p>	

<p>6.5.2.6</p>	<p>X2196</p>	 <p>201, 242, 405, 422, 501, 717, 2002, 2061, 2161, 2171, 2172, IEC</p>	<p>Electrohydraulically operated, two-stage pressure-relief valve</p> <p>Detailed and simplified forms shown.</p>
<p>6.5.2.7</p>	<p>X2197</p>	 <p>201, 242, 405, 422, 717, 2002, 2061, 2161, 2171, IEC</p>	
<p>6.5.2.8</p>	<p>X2198</p>	 <p>201, 242, 422, 2002, 2161, 2171, 2172, 2175</p>	<p>Pressure-reducing valve</p> <p>Detailed and simplified forms shown.</p>
<p>6.5.2.9</p>	<p>X2199</p>	 <p>201, 242, 422, 2002, 2161, 2171</p>	
<p>6.5.2.10</p>	<p>X2200</p>	 <p>201, 242, 405, 422, 2002, 2061, 2161, 2171</p>	<p>Single-stage pressure-reducing valve</p>
<p>6.5.2.11</p>	<p>X2201</p>	 <p>201, 242, 405, 422, 717, 2002, 2061, 2161, 2171</p>	<p>Two-stage pressure-reducing valve</p>

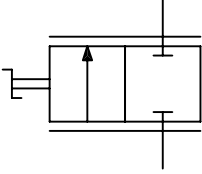
6.5.3 Flow control valves

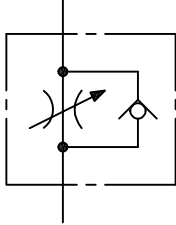
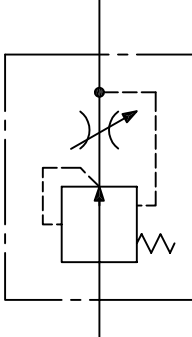
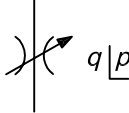
<p>6.5.3.1</p>	<p>X2211</p>	 <p>242, 402, 685, 2161, 2171, 2172, 2175</p>	<p>Adjustable restrictor (valve)</p> <p>Detailed and simplified forms shown.</p>
<p>6.5.3.2</p>	<p>X2212</p>	 <p>201, 2031, 2171</p>	
<p>6.5.3.3</p>	<p>X2213</p>	 <p>201, 405, 501, 2031, 2162, 2163, 2171</p>	<p>Adjustable restrictor (valve) with adjustable flow in one direction and restricted flow in other direction</p>
<p>6.5.3.4</p>	<p>X2214</p>	 <p>201, 242, 405, 422, 501, 2002, 2031, 2161, 2171</p>	<p>Flow control valve, pressure compensated</p> <p>Detailed and simplified forms shown.</p>
<p>6.5.3.5</p>	<p>X2215</p>	 <p>128, 201, 2031, 2171</p>	

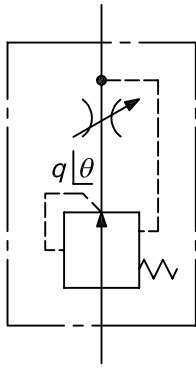
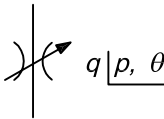
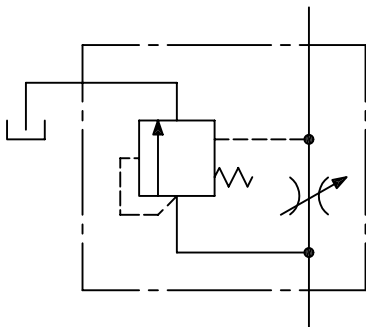
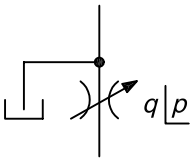
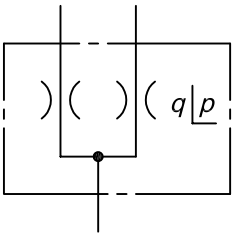
<p>6.5.3.6</p>	<p>X2216</p>	 <p>128, 201, 242, 405, 422, 501, 2002, 2031, 2161, 2171</p>	<p>Flow control valve, pressure and temperature compensated</p> <p>Detailed and simplified forms shown.</p>
<p>6.5.3.7</p>	<p>X2217</p>	 <p>128, 201, 2031, 2171</p>	
<p>6.5.3.8</p>	<p>X2218</p>	 <p>201, 242, 405, 422, 501, 2002, 2031, 2061, 2161, 2171</p>	<p>Flow control valve, pressure compensated, with overflow to reservoir</p> <p>Detailed and simplified forms shown.</p>
<p>6.5.3.9</p>	<p>X2219</p>	 <p>128, 201, 405, 501, 2031, 2061, 2171</p>	
<p>6.5.3.10</p>	<p>X2220</p>	 <p>128, 405, 501, 2031, 2171</p>	<p>Flow divider, pressure compensated</p> <p>The flow is divided into two flows in a fixed ratio.</p>

6.5.4 Non-return/check valves

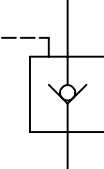
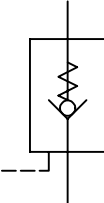
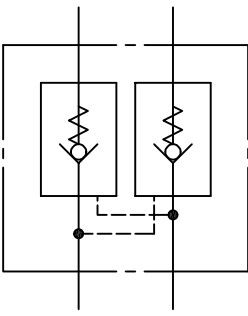
<p>6.5.4.1</p>	<p>X2231</p>	 <p>2002, 2162, 2163, 2171</p>	<p>Spring-loaded non-return valve</p>
<p>6.5.4.2</p>	<p>X2232</p>	 <p>2161, 2162, 2163, 2171</p>	<p>Pilot-operated non-return valve, closed by pilot pressure</p>
<p>6.5.4.3</p>	<p>X2233</p>	 <p>2002, 2161, 2162, 2163, 2171</p>	<p>Pilot-operated non-return valve, opened by pilot pressure against return spring</p> <p>EXAMPLE Exhaust valve.</p>
<p>6.5.4.4</p>	<p>X2234</p>	 <p>405, 422, 501, 2002, 2161, 2162, 2163, 2171</p>	<p>Pilot-controlled double non-return valve</p>

7 Hygienic valves

7.1 Symbols of a basic nature

The symbols of 6.1 shall be used.

7.2 Application rules for the symbols in 7.1

The application rules of 6.2 shall be used.

7.3 Symbols giving supplementary information

The symbols of 6.3 shall be used.

7.4 Application rules for the symbols in 7.3

The symbols and application rules of 6.4 shall be used.

7.5 Application examples

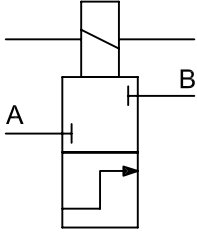
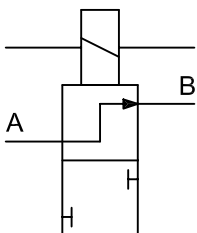
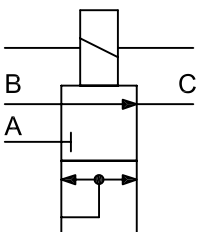
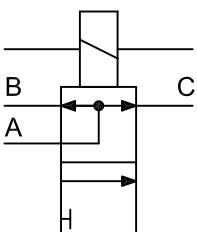
<p>7.5.1</p>	<p>X2241</p>	 <p>242, 2161, 2171, 2172, IEC</p>	<p>Hygienic valve; flow $A \Rightarrow B$ when valve is actuated</p>
<p>7.5.2</p>	<p>X2242</p>	 <p>242, 2161, 2171, 2172, IEC</p>	<p>Hygienic valve; flow $A \Rightarrow B$ when valve in at-rest position</p>
<p>7.5.3</p>	<p>X2243</p>	 <p>242, 501, 2161, 2171, 2172, IEC</p>	<p>Hygienic valve; flow $B \Rightarrow C$ when valve is in at-rest position; flow $A \Rightarrow B$ and $A \Rightarrow C$ when valve is actuated</p>
<p>7.5.4</p>	<p>X2244</p>	 <p>242, 501, 2161, 2171, 2172, IEC</p>	<p>Hygienic valve; flow $A \Rightarrow B$ and $A \Rightarrow C$ when valve is in at-rest position; flow $B \Rightarrow C$ when valve is actuated</p>

8 Valves with special functions

8.1 Symbol of a basic nature

<p>8.1.1</p>	<p>2181</p>		<p>Self-operating release valve EXAMPLES Steam trap, vent.</p>
---------------------	--------------------	---	--

8.2 Application rule for the symbol in 8.1

None.

8.3 Symbol giving supplementary information

None.

8.4 Application rule for the symbol in 8.3

None.

8.5 Application example

None.

Bibliography

- [1] ISO 4126-1:—¹⁾, *Safety devices for protection against excessive pressure — Part 1: Safety valves*
- [2] ISO 5598:1985, *Fluid power systems and components — Vocabulary*
- [3] IEC 60050-351, *International Electrotechnical Vocabulary — Part 351: Automatic control*

1) To be published. (Revision of ISO 4126-1:1991.)

ICS 01.080.30

Price based on 23 pages

© ISO 2002 – All rights reserved