

---

---

**Graphical symbols for diagrams —**  
**Part 6:**  
**Measurement and control functions**

*Symboles graphiques pour schémas —*

*Partie 6: Fonctions de mesurage et de contrôle*



Reference number  
ISO 14617-6:2002(E)

© ISO 2002

**PDF disclaimer**

This PDF file may contain embedded typefaces. In accordance with Adobe's licensing policy, this file may be printed or viewed but shall not be edited unless the typefaces which are embedded are licensed to and installed on the computer performing the editing. In downloading this file, parties accept therein the responsibility of not infringing Adobe's licensing policy. The ISO Central Secretariat accepts no liability in this area.

Adobe is a trademark of Adobe Systems Incorporated.

Details of the software products used to create this PDF file can be found in the General Info relative to the file; the PDF-creation parameters were optimized for printing. Every care has been taken to ensure that the file is suitable for use by ISO member bodies. In the unlikely event that a problem relating to it is found, please inform the Central Secretariat at the address given below.

© ISO 2002

All rights reserved. Unless otherwise specified, no part of this publication may be reproduced or utilized in any form or by any means, electronic or mechanical, including photocopying and microfilm, without permission in writing from either ISO at the address below or ISO's member body in the country of the requester.

ISO copyright office  
Case postale 56 • CH-1211 Geneva 20  
Tel. + 41 22 749 01 11  
Fax + 41 22 749 09 47  
E-mail [copyright@iso.ch](mailto:copyright@iso.ch)  
Web [www.iso.ch](http://www.iso.ch)

Printed in Switzerland

# Contents

Page

Foreword .....	iv
Introduction.....	v
1 Scope.....	1
2 Normative references.....	1
3 Terms and definitions .....	2
4 Functional links and junctions .....	3
5 Point of measurement.....	5
6 Operation of final controlling elements .....	5
7 Information-processing functions.....	10
8 Binary logic functions.....	20
9 Back-up functions .....	20
10 Examples of use of symbols in control loops.....	21
Bibliography.....	23

## Foreword

ISO (the International Organization for Standardization) is a worldwide federation of national standards bodies (ISO member bodies). The work of preparing International Standards is normally carried out through ISO technical committees. Each member body interested in a subject for which a technical committee has been established has the right to be represented on that committee. International organizations, governmental and non-governmental, in liaison with ISO, also take part in the work. ISO collaborates closely with the International Electrotechnical Commission (IEC) on all matters of electrotechnical standardization.

International Standards are drafted in accordance with the rules given in the ISO/IEC Directives, Part 3.

The main task of technical committees is to prepare International Standards. Draft International Standards adopted by the technical committees are circulated to the member bodies for voting. Publication as an International Standard requires approval by at least 75 % of the member bodies casting a vote.

Attention is drawn to the possibility that some of the elements of this part of ISO 14617 may be the subject of patent rights. ISO shall not be held responsible for identifying any or all such patent rights.

ISO 14617-6 was prepared by Technical Committee ISO/TC 10, *Technical product documentation*, Subcommittee SC 10, *Process plant documentation and tpd-symbols*.

ISO 14617 consists of the following parts, under the general title *Graphical symbols for diagrams*:

- *Part 1: General information and indexes*
- *Part 2: Symbols having general application*
- *Part 3: Connections and related devices*
- *Part 4: Actuators and related devices*
- *Part 5: Measurement and control devices*
- *Part 6: Measurement and control functions*
- *Part 7: Basic mechanical components*
- *Part 8: Valves and dampers*
- *Part 9: Pumps, compressors and fans*
- *Part 10: Fluid power converters*
- *Part 11: Devices for heat transfer and heat engines*
- *Part 12: Devices for separating, purification and mixing*
- *Part 15: Installation diagrams and network maps*

Other parts are under preparation.

## Introduction

The purpose of ISO 14617 in its final form is the creation of a library of harmonized graphical symbols for diagrams used in technical applications. This work has been, and will be, performed in close cooperation between ISO and IEC. The ultimate result is intended to be published as a standard common to ISO and IEC, which their technical committees responsible for specific application fields can use in preparing International Standards and manuals.



# Graphical symbols for diagrams —

## Part 6: Measurement and control functions

### 1 Scope

This part of ISO 14617 specifies graphical symbols for measurement and control functions in diagrams, with the same symbols in simple applications possibly representing instead components or devices implementing such functions. For graphical symbols for measurement and control components and devices, see ISO 14617-5.

For the fundamental rules of creation and application of graphical symbols in diagrams, see ISO 81714-1.

For an overview of ISO 14617, information on the creation and use of registration numbers for identifying graphical symbols used in diagrams, rules for the presentation and application of these symbols, and examples of their use and application, see ISO 14617-1.

### 2 Normative references

The following normative documents contain provisions which, through reference in this text, constitute provisions of this part of ISO 14617. For dated references, subsequent amendments to, or revisions of, any of these publications do not apply. However, parties to agreements based on this part of ISO 14617 are encouraged to investigate the possibility of applying the most recent editions of the normative documents indicated below. For undated references, the latest edition of the normative document referred to applies. Members of ISO and IEC maintain registers of currently valid International Standards.

ISO 31-11:1992, *Quantities and units — Part 11: Mathematical signs and symbols for use in the physical sciences and technology*

ISO 14617-1:2002, *Graphical symbols for diagrams — Part 1: General information and indexes*

ISO 14617-2:2002, *Graphical symbols for diagrams — Part 2: Symbols having general application*

ISO 14617-3:2002, *Graphical symbols for diagrams — Part 3: Connections and related devices*

ISO 14617-4:2002, *Graphical symbols for diagrams — Part 4: Actuators and related devices*

ISO 14617-5:2002, *Graphical symbols for diagrams — Part 5: Measurement and control devices*

ISO 14617-8:2002, *Graphical symbols for diagrams — Part 8: Valves and dampers*

ISO 81714-1:1999, *Design of graphical symbols for use in the technical documentation of products — Part 1: Basic rules*

IEC 60617-12:1997, *Graphical symbols for diagrams — Part 12: Binary logic elements*

IEC 60617-13:1993, *Graphical symbols for diagrams — Part 13: Analogue elements*

IEC 61175:1993, *Designations for signals and connections*

### 3 Terms and definitions

For the purposes of this part of ISO 14617, the following terms and definitions apply.

**NOTE** The list has been restricted to terms whose meaning is not obvious and which have not been defined elsewhere in an International Standard, or which have been defined in various ways in different standards. In preparing these definitions, ISO and IEC standards on terminology have been consulted; see the references in parentheses. However, most of the definitions in those standards were prepared by different technical committees within a restricted scope. This means that many terms so defined have to be given more general or neutral definitions when applied in the context of graphical symbols.

#### 3.1

##### **control**

purposeful action on or in a system to meet specified objectives

[IEC 60050-351]

**NOTE** Control may include monitoring and safeguarding in addition to the control action itself.

#### 3.2

##### **operation**

transfer of mechanical parts

[IEC 60050-441]

**EXAMPLE** The closing member of a shut-off valve or the contacts of an electromechanical switching device.

**NOTE 1** The transfer direction may be defined as an opening operation, closing operation, ON-operation, OFF-operation, etc.

**NOTE 2** The term has a specific meaning in conjunction with electric measuring relays. An over/under- relay is operating when its characteristic quantity reaches the set value by increasing/decreasing in value (IEC 60050-448).

#### 3.3

##### **manual control**

control of an operation by human intervention

[ISO 5598, IEC 60050-351]

#### 3.4

##### **automatic**

(control, operation) self-acting (not needing human intervention)

[ISO 5598, IEC 60050-351]

#### 3.5

##### **final controlling element**

element which directly changes the output variable of a controlling system (manipulated variable)

[IEC 60050-351]

#### 3.6

##### **delay device**

device providing a time interval between the instant when an actuating force is applied or removed and the instant when the consequent change of position or state of the affected parts start

#### 3.7

##### **automatic return device**

device for returning movable parts, such as those of a valve to initial position (at-rest position), after an actuating force has been removed



**3.8  
detent**

device which retains movable parts, for example, those of a valve, in a certain position until sufficient force is applied to overcome the detaining force in order to move the parts to another position

[ISO 5598]

**3.9  
latching device**

mechanical device giving movable parts, for example, those of a valve, the possibility to move in one direction but preventing them from returning until the latch has been released

[ISO 5598]

**3.10  
blocking device**

mechanical device preventing movable parts, for example, those of a valve, from moving in any direction until the blocking device has been released

**3.11  
interlocking device**

mechanical device making the operation of movable parts of one component, for example, a contactor, dependent on the position or state of another component with movable parts

[IEC 60050-441]

**3.12  
information processing**

performing of operations on data to obtain or treat information

**3.13  
primary location**

location of measuring instruments, potentiometers etc. accessible to an operator

cf. auxiliary location (3.14)

**3.14  
auxiliary location**

location of measuring instruments, potentiometers etc. not accessible to an operator, for example, behind a panel.

cf. primary location (3.13)

**4 Functional links and junctions**



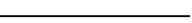
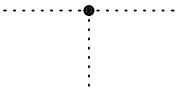



**4.1 Symbols of a basic nature**

4.1.1	401		Functional connection See R401 (4.2.1) and R402 (4.2.2).
4.1.2	501		Joint of connections See R501 (4.2.3).

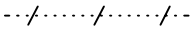
**4.2 Application rules for the symbols in 4.1**

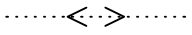
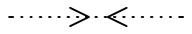
<b>4.2.1</b>	<b>R401</b>	Symbols for connections may cross each other.
<b>4.2.2</b>	<b>R402</b>	When confusion between symbols 401 (4.1.1) and 405 (3-4.1.5) to 410 (3-4.1.10) for other types of connections is likely, symbol 431 (4.3.1) shall be added.
<b>4.2.3</b>	<b>R501</b>	The diameter of the dot should be five times the width of the line.  The symbol may be omitted in a T-joint. For an example, see X505 (3-5.5.5).

**4.3 Symbols giving supplementary information**

<b>4.3.1</b>	<b>431</b>		Pure functional type
<b>4.3.2</b>	<b>249</b>		Direction of propagation, energy, or signal flow (simplex)  See R247 (4.4.1).
<b>4.3.3</b>	<b>250</b>		Direction of propagation, energy, or signal flow, alternative directions (half-duplex)  See R247 (4.4.1).
<b>4.3.4</b>	<b>251</b>		Direction of propagation, energy, or signal flow simultaneously in both directions possible (full-duplex)  See R247 (4.4.1).
<b>4.3.5</b>	<b>234</b>		Analogue signal
<b>4.3.6</b>	<b>235</b>		Digital signal
<b>4.3.7</b>	<b>236</b>		Binary signal

**4.4 Application rules for the symbols in 4.3**

<b>4.4.1</b>	<b>R247</b>	The symbol shall be shown on the connecting line and located such that it does not touch any other symbol.  The symbol may also be used to indicate the transfer direction of a component or device, in which case the symbol should be located on the outline of the basic symbol.
--------------	-------------	---

**4.5 Application examples**

See clause 10.

## 5 Point of measurement

### 5.1 Symbol of a basic nature

5.1.1	1011	○	Point of measurement See R1011 (5.2.1).
-------	------	---	--

### 5.2 Application rule for the symbol in 5.1

5.2.1	R1011	The symbol shall be used if it is necessary to clearly indicate the location of the point of measurement. For an example, see X1011 (5.5.1).	
-------	-------	--	--

### 5.3 Symbol giving supplementary information

None.

### 5.4 Application rule for the symbol in 5.3

None.

### 5.5 Application examples

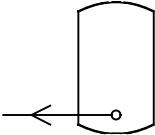
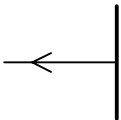
5.5.1	X1011	 249, 401, 1011, 2062	Measurement inside and near the bottom of a pressure vessel
5.5.2	X1012	 249, 401, 405	Measurement in a pipeline The use of symbol 1011 (5.1.1) is not regarded as necessary.

## 6 Operation of final controlling elements











### 6.1 Symbols of a basic nature

6.1.1	1021	)-----	Manual operation of a final controlling element
6.1.2	1022	-----○-----	Automatic operation of a final controlling element The input may be a binary (#) or an analogue (∩) signal. See R1021 (6.2.1).

**6.2 Application rules for the symbols in 6.1**

<p><b>6.2.1</b></p>	<p><b>R1021</b></p>	<p>If necessary, the input or inputs shall be provided with signal designations (see IEC 61175) indicating the action of the signals.</p> <p>When the final controlling element is of the bistable type, two input signals are needed. For an example, see X1032 (6.5.12). In many cases the diagram may be simplified by indicating the two inputs by only one functional link provided with two signal names. For an example, see X1033 (6.5.13).</p>
---------------------	---------------------	---

**6.3 Symbols giving supplementary information**

<p><b>6.3.1</b></p>	<p><b>651</b></p>	<p>Form 1</p>  <p>200 %</p>	<p>Delay device where the action is delayed when the direction of movement is towards the centre of the arc</p> <p>See R651 (6.4.1).</p>
<p><b>6.3.2</b></p>	<p><b>652</b></p>	<p>Form 2</p>  <p>200 %</p>	
<p><b>6.3.3</b></p>	<p><b>653</b></p>	 <p>200 %</p>	<p>Delay device where the action is delayed in both directions</p> <p>See R651 (6.4.1).</p>
<p><b>6.3.4</b></p>	<p><b>654</b></p>	 <p>200 %</p>	<p>Automatic return device</p> <p>The return direction is towards the apex.</p> <p>See R652 (6.4.2) and R1022 (6.4.3).</p>
<p><b>6.3.5</b></p>	<p><b>655</b></p>	 <p>200 %</p>	<p>Detent for detaining in a discrete position</p> <p>See R652 (6.4.2).</p>
<p><b>6.3.6</b></p>	<p><b>659</b></p>	 <p>200 %</p>	<p>Detent for detaining in any position</p> <p>See R652 (6.4.2).</p>
<p><b>6.3.7</b></p>	<p><b>660</b></p>	 <p>200 %</p>	<p>Detent for detaining in any position, drift to the left permitted</p> <p>See R1023 (6.4.4).</p>
<p><b>6.3.8</b></p>	<p><b>661</b></p>	 <p>200 %</p>	<p>Latching device</p>
<p><b>6.3.9</b></p>	<p><b>664</b></p>	 <p>200 %</p>	<p>Blocking device</p>
<p><b>6.3.10</b></p>	<p><b>666</b></p>	 <p>200 %</p>	<p>Interlocking device</p>

**6.4 Application rules for the symbols in 6.3**

<p><b>6.4.1</b></p>	<p><b>R651</b></p>	<p>The double line shall be attached to the symbol for the element of a component or device that is delayed. For examples, see X653 (4-4.5.3), X654 (4-5.5.4) and X1023 (6.5.3).</p>
---------------------	--------------------	--

6.4.2	R652	The symbol may be omitted if the behaviour of the component is understood by the symbol for the actuator, cf. 4-5.1, R683 (4-5.2.3) and R685 4-5.2.5). For example, see 4-5.5.
6.4.3	R1022	<p>Besides signifying the meaning automatic return when the control signal changes to zero (shut-off valves) or a lower value (control valves), the symbol shall be used for indication of automatic return when the auxiliary supply voltage or pressure fails.</p> <p>When the symbol is used in connection with a symbol for a valve (see ISO 14617-8) the following applies.</p> <ul style="list-style-type: none"> <li>— Symbol pointing towards the symbol for the valve: valve returns to, or towards, closed position when the control signal becomes zero or decreases, or when the auxiliary supply fails — for examples, see X1022 (6.5.2), X1026 (6.5.6), and X1028 (6.5.8). Cf. R5101 (8-4.2.1).</li> </ul> <p>If no ambiguity is likely, the symbol may be omitted in this case.</p> <ul style="list-style-type: none"> <li>— Symbol pointing from the symbol for the valve: valve returns to, or towards, open position when the control signal becomes zero or decreases, or when the auxiliary supply fails — for an example, see X1027 (6.5.7). Cf. R5101 (8-4.2.1).</li> </ul> <p>The symbol may be supplemented by a figure <i>n</i> %, indicating restricted closing or opening. For examples, see X1029 (6.5.9) and X1030 (6.5.10).</p> <p>When the symbol is used in connection with symbols for devices other than valves (e.g. a pump), the corresponding principle applies. For example, an automatic return symbol pointing towards the symbol for a pump implies that the pump stops (will take on its inactive state) when the output signal becomes zero or when the supply fails. For an example, see X1031 (6.5.11).</p>
6.4.4	R1023	<p>When the symbol is used in connection with a symbol for a valve, the following applies.</p> <ul style="list-style-type: none"> <li>— Symbol pointing towards the symbol for the valve: safe and permitted drift is towards closed state of the valve — for an example, see X1035 (6.5.15).</li> <li>— Symbol pointing from the symbol for the valve: safe and permitted drift is towards open state of the valve.</li> </ul>

**6.5 Application examples**

NOTE For more examples of the application of symbols for automatic return, detaining, latching, delaying, etc., see ISO 14617-4:2002, 4.5.

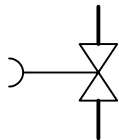
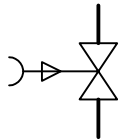
6.5.1	X1021	 <p>403, 1021, 2101</p>	Manual operation of valve
6.5.2	X1022	 <p>403, 654, 1021, 2101</p>	Manual operation of valve with automatic return to closed position

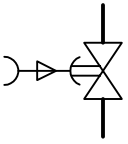
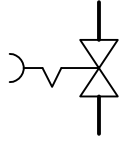
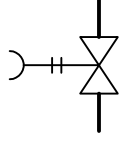
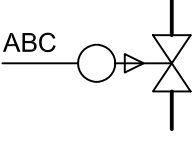
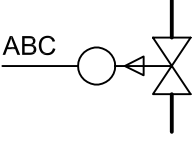
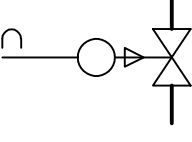
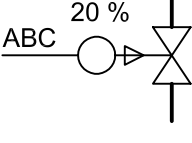
<p><b>6.5.3</b></p>	<p><b>X1023</b></p>	 <p>403, 651, 654, 1021, 2101</p>	<p>Manual operation of valve with delayed automatic return to closed position</p>
<p><b>6.5.4</b></p>	<p><b>X1024</b></p>	 <p>403, 655, 1021, 2101</p>	<p>Manual operation of valve with two stable positions, closed and open</p>
<p><b>6.5.5</b></p>	<p><b>X1025</b></p>	 <p>403, 659, 1021, 2101</p>	<p>Manual operation of valve with infinite number of stable positions</p>
<p><b>6.5.6</b></p>	<p><b>X1026</b></p>	 <p>401, 403, 654, 1022, 2101</p>	<p>Automatic operation of valve with automatic return to closed position</p> <p>When the statement ABC is true (the signal has taken on its 1-state), the valve is opened. When the statement ABC is not true (the signal has taken on its 0-state), or when the auxiliary supply fails, the valve returns to its closed position.</p>
<p><b>6.5.7</b></p>	<p><b>X1027</b></p>	 <p>401, 403, 654, 1022, 2101</p>	<p>Automatic operation of valve with automatic return to open position</p> <p>When the statement ABC is true (the signal has taken on its 1-state), the valve is closed. When the statement ABC is not true (the signal has taken on its 0-state), or when the auxiliary supply fails, the valve returns to its open position.</p>
<p><b>6.5.8</b></p>	<p><b>X1028</b></p>	 <p>234, 401, 403, 654, 1022, 2101</p>	<p>Automatic operation of valve controlled by analogue signal</p> <p>The throughput increases/decreases when the value of the analogue signal increases/decreases. When the analogue signal takes on its minimum value or when the auxiliary supply fails, the valve closes.</p>
<p><b>6.5.9</b></p>	<p><b>X1029</b></p>	 <p>401, 403, 654, 1022, 2101</p>	<p>Automatic operation of valve with automatic return towards closed position</p> <p>When the statement ABC is true (The signal has taken on its 1-state.) the valve is opened. When the statement ABC is not true (The signal has taken on its 0-state.) or when the auxiliary supply fails, the valve returns to 20 % open position.</p>

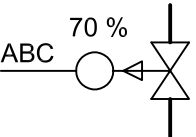
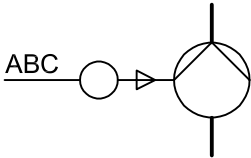
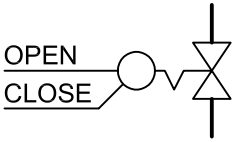
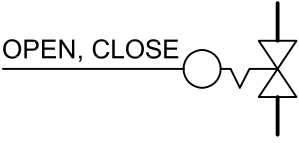
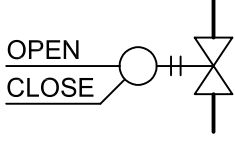
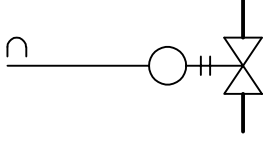
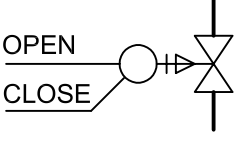
<p><b>6.5.10</b></p>	<p><b>X1030</b></p>	 <p>401, 403, 654, 1022, 2101</p>	<p>Automatic operation of valve with automatic return towards open position</p> <p>When the statement ABC is true (the signal has taken on its 1-state), the valve is closed. When the statement ABC is not true (the signal has taken on its 0-state), or when the auxiliary supply fails, the valve returns to 70 % open position.</p>
<p><b>6.5.11</b></p>	<p><b>X1031</b></p>	 <p>401, 403, 654, 1022, 2301</p>	<p>Automatic operation of pump</p> <p>When the binary input signal stands at its 1-state the pump is running. When the binary input signal takes on its 0-state or when the auxiliary supply fails, the pump stops.</p>
<p><b>6.5.12</b></p>	<p><b>X1032</b></p>	 <p>401, 403, 655, 1022, 2101</p>	<p>Automatic operation of valve with two stable positions, open and closed</p> <p>When the binary signal OPEN takes on its 1-state in the form of a pulse, the valve is instantaneously opened. When the binary signal CLOSE takes on its 1-state in the form of a pulse the valve is instantaneously closed.</p>
<p><b>6.5.13</b></p>	<p><b>X1033</b></p>	 <p>401, 403, 655, 1022, 2101</p>	<p>Two methods are shown.</p>
<p><b>6.5.14</b></p>	<p><b>X1034</b></p>	 <p>401, 403, 659, 1022, 2101</p>	<p>Automatic operation of valve with infinite number of stable positions</p> <p>When the binary signal OPEN takes on its 1-state the valve starts opening. When the binary signal CLOSE takes on its 1-state the valve starts closing. As soon as the input signal turns to 0-state the operation is interrupted.</p>
<p><b>6.5.15</b></p>	<p><b>X1035</b></p>	 <p>234, 401, 403, 659, 1022, 2101</p>	<p>Automatic operation of valve controlled by analogue signal</p> <p>The throughput increases/decreases when the value of the analogue signal increases/decreases. If the analogue signal or the auxiliary supply (if any) fails, the valve remains in its latest position.</p>
<p><b>6.5.16</b></p>	<p><b>X1036</b></p>	 <p>401, 403, 660, 1022, 2101</p>	<p>Automatic operation of valve with infinite number of stable positions</p> <p>When the binary signal OPEN takes on its 1-state the valve starts opening. When the binary signal CLOSE takes on its 1-state the valve starts closing. As soon as the input signal turns to 0-state the operation is interrupted. Drift towards the closed position is permitted.</p>

## 7 Information-processing functions

### 7.1 Symbols of a basic nature

NOTE For general application rules, see R1041 (7.2.1) to R1045 (7.2.5).

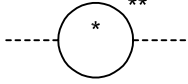
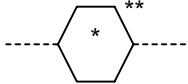
7.1.1	1041		Information-processing function
7.1.2	1042		Information-processing function performed by time-sharing, for example, in a programmable device or computer  See R1046 (7.2.6).

### 7.2 Application rules for the symbols in 7.1

7.2.1	R1041	When a symbol is provided with an enabling input, this input shall be located 90° apart from the input. For examples, see X1043 (7.5.3) and X1044 (7.5.4).  When the symbols are used for analogue signals and provided with an enabling input, the effect of the enabling signal when this has taken on its disabling state shall be noted on the opposite side of the enabling input, when applicable. For an example, see X1073 (7.5.33).
7.2.2	R1042	The asterisk shall be replaced with — first, a letter symbol for measured or initiating variable according to 7.3.1; — second, a letter symbol for modifier according to 7.3.1, when applicable; and — third, a letter or more letters for function according to 7.3.1.  The double asterisk shall be replaced with — a symbol according to 7.3.2 if the letter symbol for function is A, S or Z, when applicable, or else shall be omitted; — a symbol according to 7.3.3 if the letter symbol for function is Y.
7.2.3	R1043	If necessary, the symbols may be extended to give place for a code consisting of many letters:  <div style="text-align: center;">  </div>
7.2.4	R1044	An identifying number may be located below the letter code for function.
7.2.5	R1045	For analogue-converting or -computing functions (letter code Y), the use of symbols according to IEC 60617-13 may be used instead of the symbols given in 7.1.
7.2.6	R1046	If all measurement and control functions (except those directly connected to the process flow) are performed by time-sharing, symbol 1041 (7.1.1) may be used instead.



### 7.3 Symbols giving supplementary information

#### 7.3.1 Letter symbols for data processing functions

NOTE For application rules, see R1051 (7.4.4) to R1067 (7.4.20).







		Symbol	Measured or initiating variable	Modifier	Function
7.3.1.1	1051	A			Alarming
7.3.1.2	1052	B			Displaying discrete state
7.3.1.3	1053	C			Controlling
7.3.1.4	1054	D	Density	Difference	
7.3.1.5	1055	E	Electric variable		Sensing
7.3.1.6	1056	F	Flow rate	Ratio, fraction	
7.3.1.7	1057	G	Gauge, position, length		Viewing
7.3.1.8	1058	H	Hand		
7.3.1.9	1059	I			Indicating
7.3.1.10	1060	J	Power	Scanning	
7.3.1.11	1061	K	Time	Time rate of change	
7.3.1.12	1062	L	Level		
7.3.1.13	1063	M	Moisture, humidity	Momentarily	
7.3.1.14	1064	N	User's choice		User's choice
7.3.1.15	1065	O	User's choice		
7.3.1.16	1066	P	Pressure, vacuum		Connection of test point
7.3.1.17	1067	Q	Quality	Integral, total	Integrating, summing
7.3.1.18	1068	R	Radiation		Registering, recording
7.3.1.19	1069	S	Speed, frequency		Switching
7.3.1.20	1070	T	Temperature		Transmitting
7.3.1.21	1071	U	Multi-variable		Multi-function
7.3.1.22	1072	V	User's choice		Impact on process by valve, pump, etc.
7.3.1.23	1073	W	Weight, force	Multiplying	
7.3.1.24	1074	X	Unclassified		Unclassified
7.3.1.25	1075	Y	User's choice		Converting, computing
7.3.1.26	1076	Z	Number of events, quantity		Emergency or safety acting

7.3.2 Letter codes for set values

7.3.2.1	1081	H	High
7.3.2.2	1082	HH	Very high
7.3.2.3	1083	H2	
7.3.2.4	1084	HHH	Extremely high
7.3.2.5	1085	H3	
7.3.2.6	1086	L	Low
7.3.2.7	1087	LL	Very low
7.3.2.8	1088	L2	
7.3.2.9	1089	LLL	Extremely low
7.3.2.10	1090	L3	
7.3.2.11	1091	HL	High or low

7.3.3 Other general functions





NOTE Symbols for other general functions are to be found in ISO 14617-2. However, in order to facilitate the use of this part of ISO 14617, some of the symbols are also shown here. For the construction of mathematical expressions, see ISO 31-11.

7.3.3.1	115		Amplification NOTE The triangle is pointed in the direction of transmission.
7.3.3.2	123		Delay $t_1$ is the switch-on delay, $t_2$ the switch-off delay. See R112 (7.4.1) and the explanation in 2-4.3.2.9.
7.3.3.3	124		Hysteresis
7.3.3.4	133	Form 1 HLIM	High limitation
7.3.3.5	134	Form 2 	
7.3.3.6	135	Form 1 LLIM	Low limitation
7.3.3.7	136	Form 2 	
7.3.3.8	137		Dead band; threshold
7.3.3.9	138	HSEL	Selection of highest value

7.3.3.10	139	LSEL	Selection of lowest value
7.3.3.11	140	COMP	Comparing
7.3.3.12	142	&	Logic AND-function
7.3.3.13	143	$\geq 1$	Logic OR-function
7.3.3.14	145	$\phi$	Complex function See R116 (7.4.2).
7.3.3.15	161	$\frac{X}{Y}$	Dividing NOTE The symbol for division in the form of an oblique stroke is not used because reserved for conversion, see symbol 112 (2-4.3.2.2).
7.3.3.16	162	$X * K$	Bias See R117 (7.4.3).
7.3.3.17	163	$1 - X$	Reverse
7.3.3.18	181		Logic negation (shown at an input and an output)

7.3.4 Indication of location

NOTE For application rules, see R1101 (7.4.21).

7.3.4.1	1101		Primary location in a central control room, for example, of a control station
7.3.4.2	1102		Auxiliary location in a central control room
7.3.4.3	1103		Primary location in a local control room or on a local control panel See R1102 (7.4.22).
7.3.4.4	1104		Auxiliary location in a local control room or on a local control panel See R1102 (7.4.22).

7.4 Application rules for the symbols in 7.3

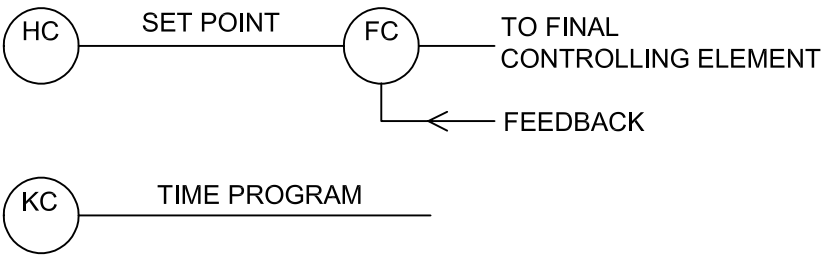
7.4.1	R112	<p>If only switch-on delay occurs, <math>t_2</math> shall be omitted or replaced with 0. If only switch-off delay occurs, <math>t_1</math> shall be omitted or replaced with 0. If <math>t_1 = t_2</math>, the notation may be replaced with the letter <math>t</math> centred.</p> <p>The notations may be replaced with the actual values.</p> <p>If the delay type is obvious, the notations may be left out.</p>
7.4.2	R116	<p>The <math>\phi</math> shall be supported by an indication of the function or a reference to an explanation. This information shall be stated within square brackets, for example, [Table 1].</p>
7.4.3	R117	<p>The asterisk shall be replaced with +, -, or <math>\pm</math>, depending on the type of bias.</p>
7.4.4	R1051	<p>When two or more code letters for function according to the last column in 7.3.1 occur, the order of sequence shall be</p> <p style="text-align: center;">G, I, B, R, C, T, X, Y, Q, S, Z, A</p> <p>Examples of complete letter codes according to this rule:</p> <p>QRC    Quality recording and control</p> <p>EIC    Indication and control of electric variable, for example, voltage</p> <p>TIT    Temperature indication and transmitting</p> <p>FRCQ   Flow rate recording and control with summation of volume</p> <p>PDICA   Pressure difference indication, control and alarm</p>
7.4.5	R1052	<p>A "User's choice" letter shall be used for unlisted meanings used repetitively in a project. The meanings shall be explained on the diagram or in a supporting document.</p>
7.4.6	R1053	<p>The letter C for function shall be used both for feedback and open loop control functions as well as for the setting of reference values. However, for control by switching on or off by the operator or by the process itself the letter S shall be used for function.</p> 
7.4.7	R1054	<p>The letter G for function refers to viewing, for example, by means of a sight glass or a television monitor.</p>
7.4.8	R1055	<p>The letter H for initiating variable stands for all types of manual actuation, for example, setting of reference value for feedback control and stop/start of a pump.</p>
7.4.9	R1056	<p>The letter I for function applies to analogue and digital readout functions of an actual measurement. It may also be used for indication of a setting value.</p> <p>NOTE 1    For discrete indication, see letter B.</p> <p>NOTE 2    For simultaneous indication and recording, see R1062 (7.4.15).</p>

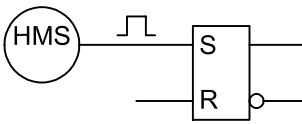
7.4.10	R1057	In the electrical field, the letter J as measured variable represents active power. For reactive power and apparent power, the letter J shall be used and, outside the circle, the annotation REACT. or APPAR.
7.4.11	R1058	The letter K as modifier shall be used for, for example, acceleration (SK) and temperature derivative (TK).
7.4.12	R1059	The letter M as modifier refers to a pulse-shaped output signal. The function of a manually actuated push-button (with automatic return) should be indicated thus:  
7.4.13	R1060	The letter P as function shall be used to indicate the possibility of connecting, for example, a testing device to a process flow path, for example, a flow rate indicator. For an example, see X1052 (7.5.12).
7.4.14	R1061	The letter Q as measured variable should be supplemented with an indication outside the circle, specifying the type of quality.
7.4.15	R1062	The letter R as function shall be used for simultaneous recording and indication.
7.4.16	R1063	For the choice between letters C and S as function, see R1053 (7.4.6).
7.4.17	R1064	When the letter U for multivariable is used, it shall be made obvious to the reader of a diagram which variables are indicated, this being done, for example, by using the diagram itself or by a reference to an explanation.
7.4.18	R1065	When the letter U for multi-function is used, it shall be made obvious to the reader of a diagram which functions are indicated, this being done, for example, by a reference to an explanation.
7.4.19	R1066	The letter X shall be used for unlisted meanings used only to a limited extent. The letter may have any number of meanings as measured variable and any number of meanings as function. The meaning shall be defined just outside the circle.
7.4.20	R1067	The letter Z as measured variable shall be used when control or monitoring responses are event-driven as opposed to time- or time schedule-driven. The letter may also signify presence or state.
7.4.21	R1101	The symbols for location may be placed at any height inside the symbols given in 7.1. Absence of a location symbol indicates that <ul style="list-style-type: none"> <li>— the location has not been decided or is of less interest, or</li> <li>— the device implementing the function is field-mounted.</li> </ul> It shall be stated on the diagram which of these two possibilities applies, if it is not already obvious.
7.4.22	R1102	The symbol may be supplemented with information on the name of the local control room or the local control panel, just outside the symbols from 7.1, for example, COMPRESSOR, i.e. the local control room or local control panel for a compressor.

7.5 Application examples

NOTE In the application examples, the signal direction is from left to right if not otherwise specified by the use of symbols 249 (4.3.2) to 251 (4.3.4).

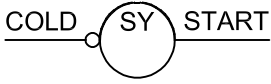
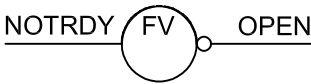
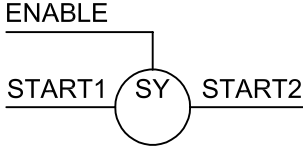
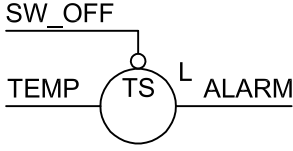
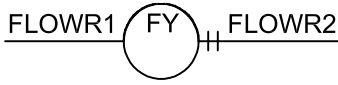
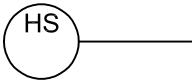
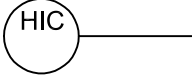
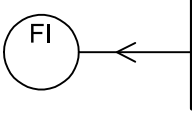
<p>7.5.1</p>	<p>X1041</p>	 <p>181, 401, 1041, 1069, 1075</p>	<p>Information processing function with negated input</p> <p>When the statement COLD is true, then the statement START is not true (is false).</p>
<p>7.5.2</p>	<p>X1042</p>	 <p>181, 401, 1041, 1056, 1072</p>	<p>Information processing function with negated output</p> <p>When the statement NOTRDY (not ready) is true, then the statement OPEN is not true.</p>
<p>7.5.3</p>	<p>X1043</p>	 <p>401, 1041, 1069, 1075</p>	<p>Information processing function with enabling</p> <p>When the statement START1 is true, the statement START2 is true provided the statement ENABLE is true.</p>
<p>7.5.4</p>	<p>X1044</p>	 <p>181, 401, 1041, 1069, 1070</p>	<p>Information processing function with negated enabling (disabling)</p> <p>If the temperature is low, then the statement ALARM is true provided the statement SW_OFF is not true.</p>
<p>7.5.5</p>	<p>X1045</p>	 <p>401, 659, 1041, 1056, 1075</p>	<p>Information processing function with retained output signal</p> <p>The value of the signal FLOWR2 (flow rate 2) is the same as that of the signal FLOWR1. However, if FLOWR1 disappears, FLOWR2 maintains its latest value.</p>
<p>7.5.6</p>	<p>X1046</p>	 <p>401, 1041, 1058, 1069</p>	<p>Manual switching, for example, for start and stop of motor-pump set</p>
<p>7.5.7</p>	<p>X1047</p>	 <p>401, 1041, 1053, 1058, 1059</p>	<p>Manual setting of set value of feedback control function with indication of set value, or manual control of control valve with indication</p>
<p>7.5.8</p>	<p>X1048</p>	 <p>249, 401, 405, 1041, 1056, 1059</p>	<p>Flow rate indication</p>

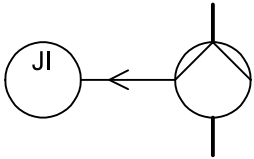
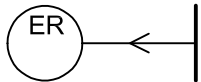
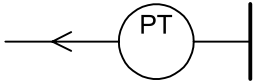
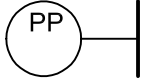
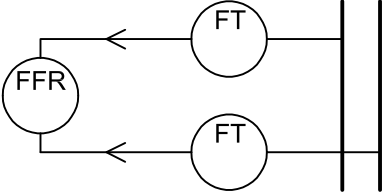
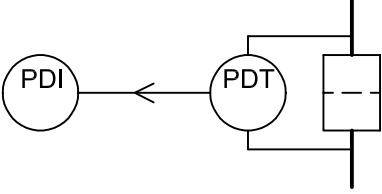
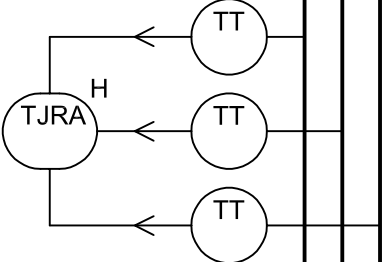
<p>7.5.9</p>	<p>X1049</p>	 <p>249, 401, 1041, 1059, 1060, 2301</p>	<p>Pump motor power indication</p>
<p>7.5.10</p>	<p>X1050</p>	<p>VOLT.</p>  <p>249, 401, 405, 1041, 1055, 1068</p>	<p>Voltage registering</p>
<p>7.5.11</p>	<p>X1051</p>	 <p>249, 401, 405, 1041, 1066, 1070</p>	<p>Pressure transmitting</p>
<p>7.5.12</p>	<p>X1052</p>	 <p>401, 405, 1041, 1066</p>	<p>Pressure testing facility by direct connection to process flow</p>
<p>7.5.13</p>	<p>X1053</p>	 <p>249, 401, 405, 1041, 1056, 1068, 1070</p>	<p>Flow rate transmitting and registering of ratio between two flow rates</p>
<p>7.5.14</p>	<p>X1054</p>	 <p>249, 301, 401, 405, 1041, 1054, 1059, 1066, 1070, 2602</p>	<p>Difference pressure transmitting for strainer and indication</p>
<p>7.5.15</p>	<p>X1055</p>	 <p>249, 401, 405, 1041, 1051, 1060, 1068, 1070, 1081</p>	<p>Temperature registering by scanning and alarm at high temperature</p>

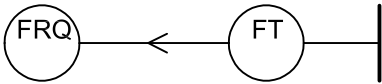
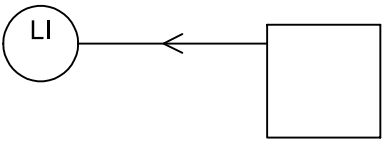
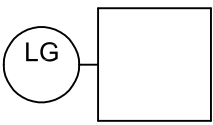
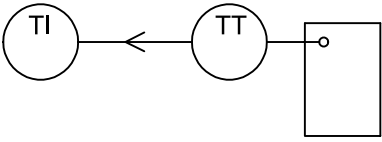
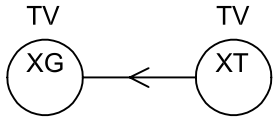
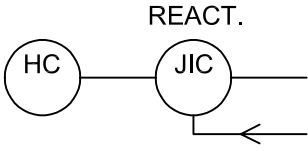
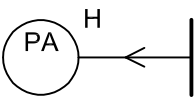
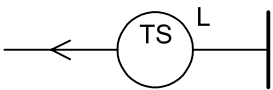
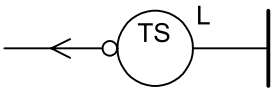
<p>7.5.16</p>	<p>X1056</p>	 <p>249, 401, 405, 1041, 1056, 1067, 1068, 1070</p>	<p>Recording of flow rate with summation of volume</p>
<p>7.5.17</p>	<p>X1057</p>	 <p>249, 401, 1041, 1059, 1062, 2061</p>	<p>Indication of level in a vessel</p>
<p>7.5.18</p>	<p>X1058</p>	 <p>401, 1041, 1057, 1062, 2061</p>	<p>Indication of level in a vessel by viewing</p>
<p>7.5.19</p>	<p>X1059</p>	 <p>249, 401, 1011, 1041, 1059, 1070, 2061</p>	<p>Measuring point inside and at top of vessel, temperature transmitting and indication</p>
<p>7.5.20</p>	<p>X1060</p>	 <p>249, 401, 1041, 1057, 1070, 1074</p>	<p>Television transmission and monitoring</p>
<p>7.5.21</p>	<p>X1061</p>	 <p>249, 401, 1041, 1053, 1058, 1059, 1060</p>	<p>Indication and feedback control of electric reactive power</p>
<p>7.5.22</p>	<p>X1062</p>	 <p>249, 401, 405, 1041, 1051, 1066, 1081</p>	<p>High-pressure alarm</p>
<p>7.5.23</p>	<p>X1063</p>	 <p>249, 401, 405, 1041, 1069, 1070, 1086</p>	<p>Temperature switching The output signal takes on its 1-state when the temperature assumes a value below the set point.</p>
<p>7.5.24</p>	<p>X1064</p>	 <p>181, 249, 401, 405, 1041, 1069, 1070, 1086</p>	<p>Temperature switching The output signal takes on its 0-state when the temperature assumes a value below the set point.</p>

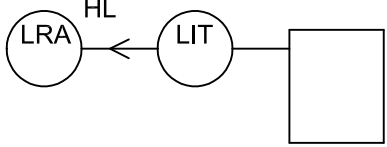
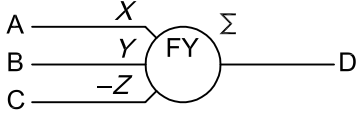
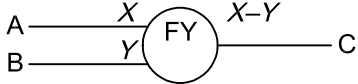
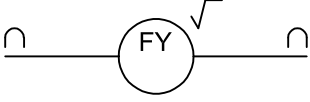
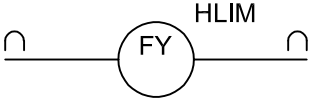
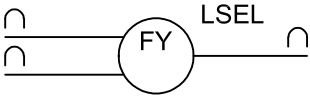
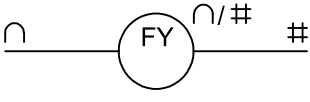
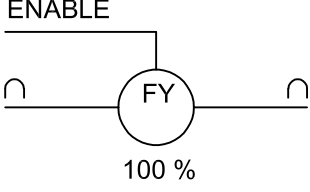

<p>7.5.25</p>	<p>X1065</p>	 <p>249, 401, 1041, 1051, 1059, 1062, 1068, 1070, 1091, 2061</p>	<p>Indicating and transmitting of level in a vessel, registering and alarm at high or low level</p>
<p>7.5.26</p>	<p>X1066</p>	 <p>106, 401, 1041, 1056, 1075</p>	<p>Summing of flow rate signals: <math>D = A + B - C</math></p>
<p>7.5.27</p>	<p>X1067</p>	 <p>106, 401, 1041, 1056, 1075</p>	<p>Subtraction of flow rate signals: <math>C = A - B</math></p>
<p>7.5.28</p>	<p>X1068</p>	 <p>234, 401, 1041, 1056, 1075</p>	<p>Square root extraction of flow rate signal</p>
<p>7.5.29</p>	<p>X1069</p>	 <p>133, 234, 401, 1041, 1056, 1075</p>	<p>Limitation of high values of flow rate signal</p>
<p>7.5.30</p>	<p>X1070</p>	 <p>139, 234, 401, 1041, 1056, 1075</p>	<p>Selection of the lowest flow rate signal</p>
<p>7.5.31</p>	<p>X1071</p>	 <p>112, 234, 235, 401, 1041, 1056, 1075</p>	<p>Conversion of analogue flow rate signal to digital form</p>
<p>7.5.32</p>	<p>X1072</p>	 <p>234, 401, 1041, 1056, 1075</p>	<p>Flow rate computing When the enabling binary signal takes on its 1-state the output signal is the same as the input signal. When the enabling signal takes on its 0-state the output signal assumes a value representing 100 % of the rated value of the flow rate.</p>

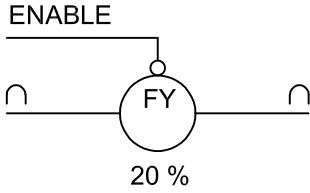
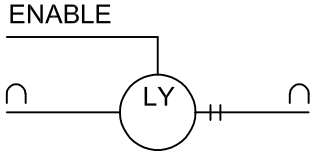
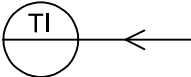
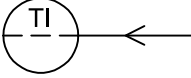
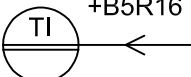
7.5.33	X1073	 <p>181, 234, 401, 1041, 1056, 1075</p>	<p>Flow rate computing</p> <p>When the enabling binary signal takes on its 0-state the output signal is the same as the input signal. When the enabling signal takes on its 1-state the output signal assumes a value representing 20 % of the rated value of the quantity being measured.</p>
7.5.34	X1074	 <p>234, 401, 659, 1041, 1062, 1075</p>	<p>Level computing</p> <p>When the enabling binary signal takes on its 1-state the output signal is the same as the input signal. When the enabling signal takes on its 0-state the output signal retains its latest momentary value.</p>
7.5.35	X1075	 <p>249, 401, 1041, 1059, 1070, 1101</p>	<p>Temperature indication in central control room</p>
7.5.36	X1076	 <p>249, 401, 1041, 1059, 1070, 1102</p>	<p>Temperature indication in central control room; instrument not accessible to the operator</p>
7.5.37	X1077	 <p>249, 401, 1041, 1059, 1070, 1103</p>	<p>Temperature indication in local control room designated +B5R16 or on local control panel in that room</p>

## 8 Binary logic functions

See IEC 60617-12.

## 9 Back-up functions

### 9.1 Symbols of a basic nature

See 7.1.

### 9.2 Application rule for symbols in 9.1

9.2.1	R1201	<p>Back-up functions shall be indicated by a symbol abutted on the symbol for the ordinary function and unconnected to the functional link. For an example, see X1081 (9.5.1).</p>
-------	-------	--

### 9.3 Symbol giving supplementary information

None.

**9.4 Application rule for symbol in 9.3**

None.

**9.5 Application example**

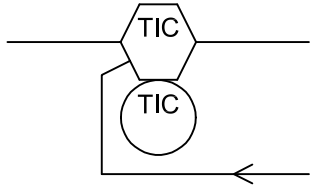
<p><b>9.5.1</b></p>	<p><b>X1081</b></p>	 <p>249, 401, 1041, 1042, 1053, 1059, 1070</p>	<p>Temperature indication and control performed by computer with back-up by discrete device</p>
---------------------	---------------------	---	---

**10 Examples of use of symbols in control loops**

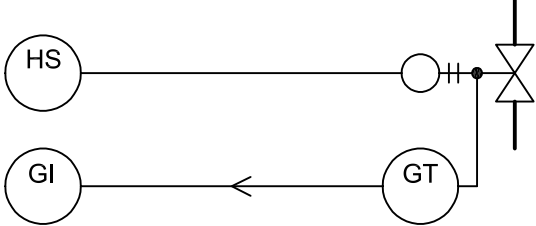
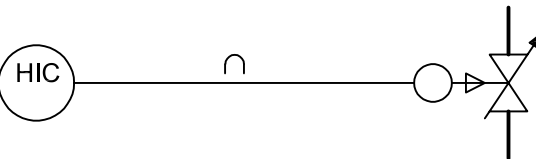
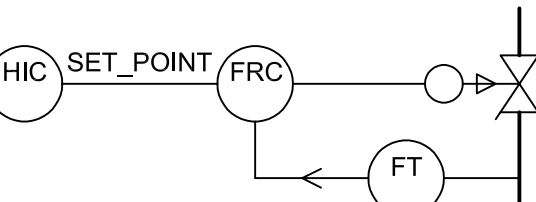
<p><b>10.1</b></p>	<p><b>X1101</b></p>	 <p>401, 403, 654, 1022, 1041, 1058, 1069, 2101</p>	<p>Manual, remote control of valve with automatic return to closed position</p>
<p><b>10.2</b></p>	<p><b>X1102</b></p>	 <p>249, 401, 403, 501, 659, 1022, 1041, 1057, 1058, 1059, 1069, 1070, 2101</p>	<p>Manual, remote control of valve with infinite number of stable positions and indication of the valve position</p>
<p><b>10.3</b></p>	<p><b>X1103</b></p>	 <p>201, 234, 401, 403, 654, 1022, 1041, 1053, 1058, 1059, 2101</p>	<p>Manual, remote control of control valve with indication of set value</p>
<p><b>10.4</b></p>	<p><b>X1104</b></p>	 <p>201, 249, 401, 403, 654, 1022, 1041, 1053, 1056, 1058, 1059, 1068, 1070, 2101</p>	<p>Flow rate feedback control</p>

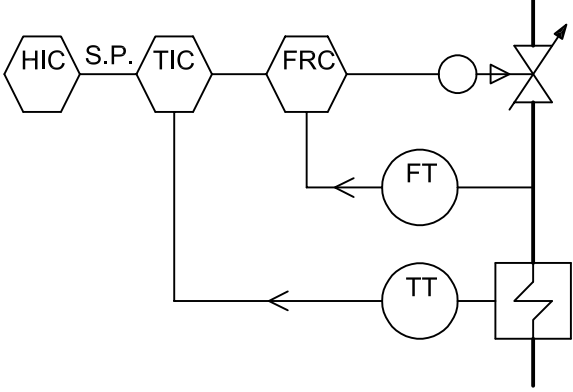
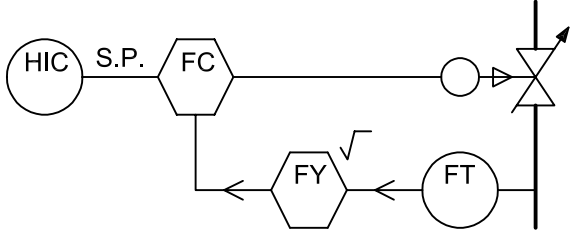
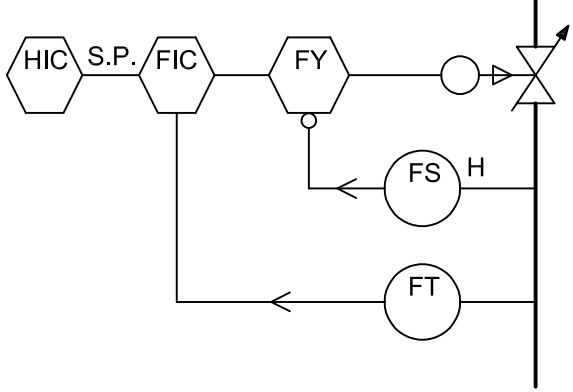
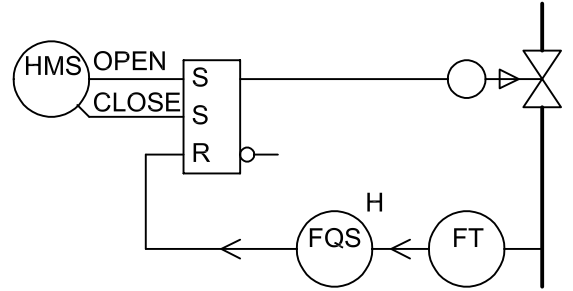
<p>10.5</p>	<p>X1105</p>	 <p>201, 249, 301, 401, 403, 654, 1022, 1041, 1042, 1053, 1056, 1058, 1059, 1068, 1070, 2101, 2501</p>	<p>Temperature-flow rate cascade control</p>
<p>10.6</p>	<p>X1106</p>	 <p>201, 249, 401, 403, 654, 1022, 1041, 1042, 1053, 1056, 1058, 1059, 1070, 1075, 2101</p>	<p>Flow rate feedback control, based on square-root value of flow rate</p>
<p>10.7</p>	<p>X1107</p>	 <p>181, 201, 249, 401, 403, 654, 1022, 1041, 1042, 1053, 1056, 1058, 1059, 1069, 1070, 1075, 1081, 2101</p>	<p>Flow rate feedback control with automatic closing of valve at flow rate higher than set value</p>
<p>10.8</p>	<p>X1108</p>	 <p>101, 106, 181, 249, 401, 403, 654, 1022, 1041, 1056, 1058, 1063, 1067, 1069, 1070, 1081, 2101, IEC</p>	<p>Flow rate feedback control where valve opens at manual command and closes when preset volume reached or by manual stop command</p>

## Bibliography

- [1] ISO 5598:1985, *Fluid power systems and components — Vocabulary*
- [2] IEC 60050-351, *International Electrotechnical Vocabulary — Part 351: Automatic control*
- [3] IEC 60050-441, *International Electrotechnical Vocabulary — Part 441: Switchgear, controlgear and fuses*
- [4] IEC 60050-448, *International Electrotechnical Vocabulary — Part 448: Power system protection*

---

---

**ICS 01.080.30**

Price based on 23 pages

© ISO 2002 – All rights reserved