**Fine ceramics (advanced ceramics,
advanced technical ceramics) — Test
method for open-hole tension of
continuous fibre-reinforced ceramic
matrix composites at room temperature**

*Céramiques techniques — Méthode d'essai de traction d'éprouvette
trouée de composites à matrice céramique renforcés de fibres
continues à température ambiante*



Reference number
ISO 14603:2012(E)

© ISO 2012



COPYRIGHT PROTECTED DOCUMENT

© ISO 2012

All rights reserved. Unless otherwise specified, no part of this publication may be reproduced or utilized in any form or by any means, electronic or mechanical, including photocopying and microfilm, without permission in writing from either ISO at the address below or ISO's member body in the country of the requester.

ISO copyright office
Case postale 56 • CH-1211 Geneva 20
Tel. + 41 22 749 01 11
Fax + 41 22 749 09 47
E-mail copyright@iso.org
Web www.iso.org

Published in Switzerland

Contents

Page

Foreword	iv
1 Scope	1
2 Normative references	1
3 Terms and definitions	1
4 Principle	2
5 Apparatus	2
5.1 Test machine	2
5.2 Load train and grip	2
5.3 Strain measurement	2
5.4 Data recording system	3
5.5 Dimension-measuring devices	3
6 Test specimens	3
7 Test specimen preparation	5
7.1 Machining and preparation	5
7.2 Number of test specimens	5
8 Test condition	5
9 Test procedure	5
9.1 Displacement or loading rate	5
9.2 Measurement of test specimen dimensions	5
9.3 Strain gauges	6
9.4 Bending load	6
9.5 Test specimen mounting	6
9.6 Measurement	6
9.7 Test validity	6
10 Calculation of results	7
10.1 Open-hole tensile strength	7
10.2 Average value, standard deviation and coefficient of variation	7
11 Test report	7
Bibliography	9

.....

Foreword

ISO (the International Organization for Standardization) is a worldwide federation of national standards bodies (ISO member bodies). The work of preparing International Standards is normally carried out through ISO technical committees. Each member body interested in a subject for which a technical committee has been established has the right to be represented on that committee. International organizations, governmental and non-governmental, in liaison with ISO, also take part in the work. ISO collaborates closely with the International Electrotechnical Commission (IEC) on all matters of electrotechnical standardization.

International Standards are drafted in accordance with the rules given in the ISO/IEC Directives, Part 2.

The main task of technical committees is to prepare International Standards. Draft International Standards adopted by the technical committees are circulated to the member bodies for voting. Publication as an International Standard requires approval by at least 75 % of the member bodies casting a vote.

Attention is drawn to the possibility that some of the elements of this document may be the subject of patent rights. ISO shall not be held responsible for identifying any or all such patent rights.

ISO 14603 was prepared by Technical Committee ISO/TC 206, *Fine ceramics*.

.....

Fine ceramics (advanced ceramics, advanced technical ceramics) — Test method for open-hole tension of continuous fibre-reinforced ceramic matrix composites at room temperature

1 Scope

This International Standard describes a test method for the determination of open-hole tensile strengths of ceramic matrix composite materials with continuous fibre reinforcement at room temperature. This method applies to all ceramic matrix composites with a continuous fibre reinforcement, bi-directional (2D), and tri-directional (xD , with $2 < x \leq 3$), tested along an arbitrary axis of reinforcement.

This test method is useful for two different objectives. One is material characterizations including material selections, and the other is determination of the stress allowable for designing a component with holes.

2 Normative references

The following documents, in whole or in part, are normatively referenced in this document and are indispensable for its application. For dated references, only the edition cited applies. For undated references, the latest edition of the referenced document (including any amendments) applies.

ISO 7500-1, *Metallic materials — Verification of static uniaxial testing machines — Part 1: Tension/compression testing machines — Verification and calibration of the force-measuring system*

ISO 3611, *Geometrical product specifications (GPS) — Dimensional measuring equipment: Micrometers for external measurements — Design and metrological characteristics*

3 Terms and definitions

For the purposes of this document, the following terms and definitions apply.

3.1 gauge length GL

length calculated by subtracting the grip lengths (both sides) from the specimen overall length

3.2 initial cross-section area

A_0
initial cross-section of the test specimen (disregarding hole)

3.3 tensile strain

ϵ
strain measured by a strain gauge at a given location on the test specimen surface

3.4 maximum tensile force

F_m
highest recorded tensile force in a tension test on the test specimen when tested to failure

3.5 open-hole tensile strength

S_m
ratio of the maximum tensile force to the initial cross-section area

3.6

minimum distance between holes

T

minimum distance between holes in a structural component with aligned holes

4 Principle

A test specimen with a circular hole of specified dimensions is loaded in tension. The test is performed at a constant crosshead displacement rate or at a constant loading rate. The force and longitudinal deformation are measured and recorded simultaneously.

5 Apparatus

5.1 Test machine

The machine shall be equipped with a system for measuring the force applied to the test specimen which shall conform to grade 1 or better according to ISO 7500-1.

5.2 Load train and grip

The load train is composed of the moveable and fixed crosshead, the loading rods and the grips. A direct-type hydraulic or mechanical grip can be used as shown in Figure 1. Load-train couplers may additionally be used to connect the grips to the loading rods to prevent bending and/or torsion.

The load train shall align the test specimen axis with the direction of force application without introducing bending or torsion in the test specimen. The grips shall apply sufficient lateral pressure to prevent slippage between the grip face and the specimen.

Grips are used to clamp and load the test specimen. The grip design shall prevent the test specimen from slipping. The grips must align the test specimen axis with that of the applied force.

The misalignment of the specimen, as well as the load train, might be checked according to CEN/TS 15867.

5.3 Strain measurement

For continuous measurement of the longitudinal deformation as a function of the applied force strain gauges should be used. If the misalignment of the specimen, as well as the load train, is checked according to CEN/TS 15867 before testing, the strain measurement for each specimen can be omitted.

Strain gauges are used for the verification of the alignment on the test specimen. They may also be used for measuring longitudinal deformation during testing. In both cases, the length of the strain gauges shall be such that the readings are not affected by local features on the surface of the specimen such as fibre crossovers. Care shall be taken to ensure that the strain gauge readings are not influenced by the surface preparation and the adhesive used. In principle, the length of strain gauge is more than twice the length of unit-cell size for $2D$ and xD composites.

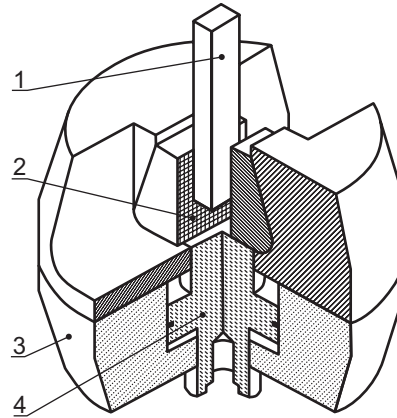

Key

- 1 specimen
- 2 wedge grip face
- 3 grip body
- 4 grip mechanism

Figure 1 — Example of indirect wedge-type grip faces

5.4 Data recording system

A calibrated recorder may be used to record force-deformation curves.

5.5 Dimension-measuring devices

Devices used for measuring linear dimensions of the test specimen shall be accurate to $\pm 0,01$ mm. Micrometers shall be in accordance with ISO 3611.

6 Test specimens

The test specimen geometry of a plate-shaped specimen is represented in Figure 2, and recommended dimensions are given in Table 1. There are two types of test specimen geometries for the different purposes.

- For material characterization purposes including materials selections, the specimen width (b) shall be $6 \times d$.
- For stress that is allowable for determination purposes to design a component with aligned holes as shown in Figure 3, two cases should be considered depending on the minimum distance (T) between holes in the structural component. If $T \geq 6d$, the specimen width (b) shall be $6 \times d$. If $T < 6d$, the specimen width (b) shall be $T/2$.

For the surface finish condition, two types of test specimens can be distinguished:

- As-fabricated test specimens, where only the length and the width are machined to the specified size. In this case, the two faces of the test specimen may present irregular surfaces while the two edges present regular machined surfaces.
- Machined test specimens, where the length and the width, as well as the two faces of the test specimen, have been machined and present regular machined surfaces.

Tolerance on the thickness dimension only applies to machined test specimens.

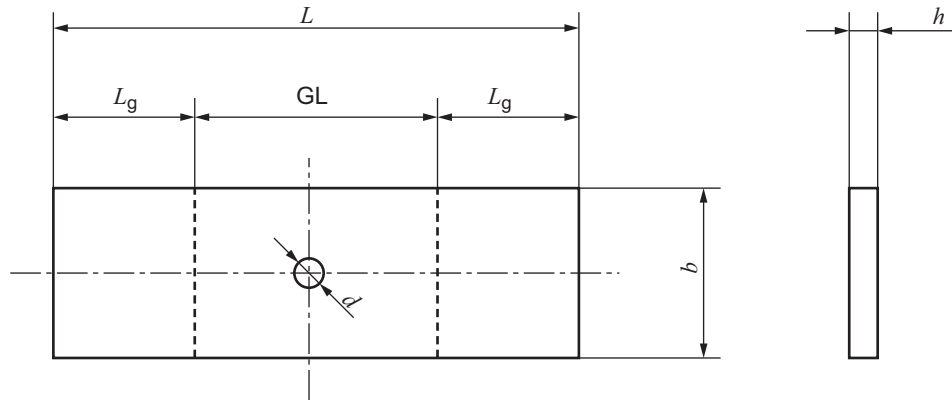

Figure 2 — Open-hole tension test specimen

Table 1 — Recommended dimensions for open-hole tension test specimen

Dimensions in millimetres

	1D, 2D, xD	Tolerance
<i>d</i> , hole diameter	$10 \geq d \geq 4$	$\pm 0,05$
<i>L</i> , total length	$\geq 20 \times d$	—
GL, gauge length	$\geq 10 \times d$	± 2
<i>h</i> , specimen thickness	$6 \geq h \geq 1,5$	— (as-fabricated test specimens) $\pm 0,05$ (machined test specimens)
<i>b</i> , specimen width	$6 \times d$ or $T/2$ ^a	$\pm 0,1$
<i>L_g</i> , gripping length	$\geq 5 \times d$	± 2
Parallelism of specimen width	0,05	—
Parallelism of specimen thickness (only for machined test specimens)	0,05	—

^a *T*; minimum distance between holes in a structural component with aligned holes (see Figure 3).

© ISO 2012 – All rights reserved

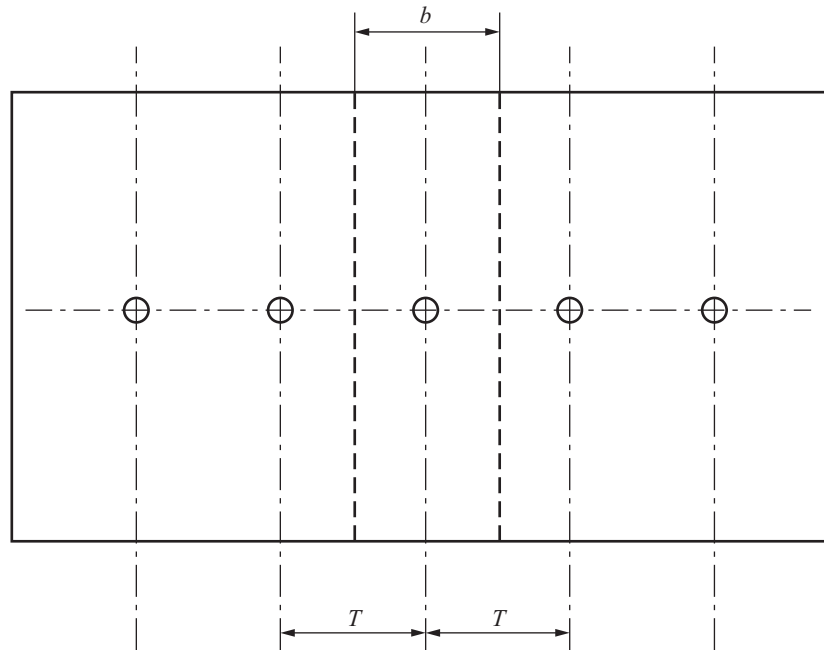

Figure 3 — Schematic drawing illustrating the definition of the minimum distance between holes in a structural component with aligned holes

7 Test specimen preparation

7.1 Machining and preparation

When extracting test specimens from as-fabricated plates of material, care shall be taken to align the test specimen axis with the desired fibre-related loading axis.

Machining parameters which avoid damage to the material shall be established and documented. These parameters shall be adhered to during test specimen preparation.

7.2 Number of test specimens

At least five valid test results (9.6) are required.

8 Test condition

The temperature and relative humidity of the room shall be $23\text{ °C} \pm 2\text{ °C}$, and $50\% \pm 10\%$, respectively.

9 Test procedure

9.1 Displacement or loading rate

The test shall be carried out under constant displacement or loading rate. Use a displacement or loading rate which allows test specimen failure between 10 and 60 s. The displacement or loading rate shall be reported.

9.2 Measurement of test specimen dimensions

The cross-section area shall be determined at the centre of the test specimen and at the two portions 15 mm from the centre. The arithmetic means of the measurements shall be used for calculations.

Necessary dimensions shall be measured with an accuracy of $\pm 0,01\text{ mm}$.

9.3 Strain gauges

Double strain gauges shall be located on both sides of the specimen centreline 15 mm from the centre of the circular hole, in order to ascertain the bending load.

9.4 Bending load

During a tensile test, the test specimen may be subjected to bending. To be sure of the validity of the test, it is necessary to verify that no bending occurs under the conditions of the test. This verification shall be carried out every time. If the misalignment of the specimen as well as the load train is checked according to CEN/TS 15867 before testing, this process can be skipped.

The degree of bending is acceptable if the differences between the back-to-back strain measurements appears for the values of linear stress/strain domain remains such that:

$$\left| \frac{\varepsilon' - \varepsilon''}{\varepsilon' + \varepsilon''} \right| \leq 0,2 \quad (1)$$

where

ε' is the tensile strain measured on the front face;

ε'' is the tensile strain measured on the back face in the same cross-section.

A system showing excessive bending for the given application should be readjusted or modified.

9.5 Test specimen mounting

Install the test specimen in the gripping system or loading system with its longitudinal axis coinciding with that of the test machine. Care shall be taken not to induce flexural or torsional loads.

Tabs made of aluminium, copper, glass fibre reinforced polymer composites (GFRP), cardboards, and others can be bonded on the specimen grip areas. These tabs are effective for axis alignment, and for preventing fracture in the grips.

9.6 Measurement

The test procedure is as follows;

- zero the force transducer;
- zero the strain gauges;
- initiate recording the force versus longitudinal deformation (or strain);
- initiate loading the test specimen and terminate loading of the test specimen at the end of test;
- terminate recording the force versus longitudinal deformation (or strain);
- note the maximum tensile force and the position of fracture location.

9.7 Test validity

The following circumstances invalidate a test:

- failure to specify and record test conditions;
- failure to meet specified test conditions;
- failure to meet bending criteria according to 9.4;

- test specimen slippage in the grips;
- fracture in the grips;
- fracture in an area without a circular hole;
- failure by shear.

10 Calculation of results

10.1 Open-hole tensile strength

Calculate the open-hole tensile strength using Formula (2):

$$S_m = \frac{F_m}{A_o} = \frac{F_m}{bh} \quad (2)$$

where

S_m is the open-hole tensile strength (Pa, usually reported in MPa);

F_m is the maximum tensile force (N);

A_o is the initial cross-sectional area of the test specimen (m²);

b is the specimen average width (m) (hole diameter not subtracted from specimen width);

h is the specimen thickness (m).

10.2 Average value, standard deviation and coefficient of variation

For each series of tests, calculate the average value, standard deviation and coefficient of variation:

$$s = \sqrt{\frac{\sum (x - \bar{x})^2}{n - 1}} \quad (3)$$

$$C_V = \frac{s}{\bar{x}} \times 100 \quad (4)$$

where

\bar{x} is the average value (MPa);

x is the test value (MPa);

s is the estimated standard deviation;

n is the number of specimens;

C_V is the coefficient of variation (%).

11 Test report

The test report shall contain at least the following information:

- a) name and address of the testing establishment;
- b) date of the test, unique identification of report and of each page, customer name and address and signatory;

ISO 14603:2012(E)

- c) a reference to this International Standard, i.e. “determined in accordance with ISO 14603:2012”;
- d) test specimen drawing or reference;
- e) description of test material (material type, manufacturing code, batch number, direction of fibre reinforcement, others);
- f) description of test set-up (gauge length, gripping system or loading system, strain gauge type, force transducer);
- g) displacement rate (mm/min) or loading rate (N/min);
- h) number of tests carried out and the number of valid results obtained;
- i) valid results, mean value and standard deviations of the open-hole tensile strength (MPa);
- j) fracture location of all the test specimens used to obtain the above results;
- k) other information.

Bibliography

- [1] CEN/TS 15867, *Advanced technical ceramics — Ceramic composites — Guide to the determination of the degree of misalignment in uniaxial mechanical tests*

© ISO 2012. All rights reserved.

ICS 81.060.30

Price based on 9 pages