

# INTERNATIONAL STANDARD

# ISO 14535

First edition  
2001-07-15

---

---

## Photography — Room-light loading packages for electronic scanners and image-setting film and paper rolls — Dimensions and related requirements

*Photographie — Emballages de chargement à la lumière artificielle pour  
scanners électroniques, et films et rouleaux de papier pour régler l'image —  
Dimensions et exigences connexes*



Reference number  
ISO 14535:2001(E)

© ISO 2001

**PDF disclaimer**

This PDF file may contain embedded typefaces. In accordance with Adobe's licensing policy, this file may be printed or viewed but shall not be edited unless the typefaces which are embedded are licensed to and installed on the computer performing the editing. In downloading this file, parties accept therein the responsibility of not infringing Adobe's licensing policy. The ISO Central Secretariat accepts no liability in this area.

Adobe is a trademark of Adobe Systems Incorporated.

Details of the software products used to create this PDF file can be found in the General Info relative to the file; the PDF-creation parameters were optimized for printing. Every care has been taken to ensure that the file is suitable for use by ISO member bodies. In the unlikely event that a problem relating to it is found, please inform the Central Secretariat at the address given below.

© ISO 2001

All rights reserved. Unless otherwise specified, no part of this publication may be reproduced or utilized in any form or by any means, electronic or mechanical, including photocopying and microfilm, without permission in writing from either ISO at the address below or ISO's member body in the country of the requester.

ISO copyright office  
Case postale 56 • CH-1211 Geneva 20  
Tel. + 41 22 749 01 11  
Fax + 41 22 749 09 47  
E-mail [copyright@iso.ch](mailto:copyright@iso.ch)  
Web [www.iso.ch](http://www.iso.ch)

Printed in Switzerland

## Contents

	Page
1 Scope .....	1
2 Normative references .....	1
3 Conditions for measurement of dimensions .....	1
4 Film and paper dimensions .....	1
5 Winding orientation .....	1
6 Dimensions of flanges .....	2
7 Packaging .....	4
8 Leader .....	4
9 Package marking .....	5
10 Compliance .....	5
Bibliography.....	6

## Foreword

ISO (the International Organization for Standardization) is a worldwide federation of national standards bodies (ISO member bodies). The work of preparing International Standards is normally carried out through ISO technical committees. Each member body interested in a subject for which a technical committee has been established has the right to be represented on that committee. International organizations, governmental and non-governmental, in liaison with ISO, also take part in the work. ISO collaborates closely with the International Electrotechnical Commission (IEC) on all matters of electrotechnical standardization.

International Standards are drafted in accordance with the rules given in the ISO/IEC Directives, Part 3.

Draft International Standards adopted by the technical committees are circulated to the member bodies for voting. Publication as an International Standard requires approval by at least 75 % of the member bodies casting a vote.

Attention is drawn to the possibility that some of the elements of this International Standard may be the subject of patent rights. ISO shall not be held responsible for identifying any or all such patent rights.

International Standard ISO 14535 was prepared by Technical Committee ISO/TC 42, *Photography*.

## Introduction

Room-light operation has become increasingly attractive to users of electronic-scanner output equipment and image-setting devices. This equipment requires accurate cassettes and a good sensitized material/equipment interface, especially where accurate registration is an important feature, e.g. in colour work.

This International Standard is required in order to define the room-light loading packages which must interface with the above equipment.

Copyright International Organization for Standardization

# Photography — Room-light loading packages for electronic scanners and image-setting film and paper rolls — Dimensions and related requirements

## 1 Scope

This International Standard applies to room-light loading packages either containing photographic film or paper rolls for electronic scanners or image-setting devices. It specifies the dimensions of the package and its contents, critical equipment interfacing features, and package marking. The prime aim of this International Standard is to ensure compatibility between room-light loading packages and the equipment in which it is used.

Two types of package are recognized. One type uses a rigid flange into which mandrils on the exposing device are inserted. The other type uses a flexible flange and relies on the exposing equipment design to hold the roll correctly in the machine.

## 2 Normative references

The following normative documents contain provisions which, through reference in this text, constitute provisions of this International Standard. For dated references, subsequent amendments to, or revisions of, any of these publications do not apply. However, parties to agreements based on this International Standard are encouraged to investigate the possibility of applying the most recent editions of the normative documents indicated below. For undated references, the latest edition of the normative document referred to applies. Members of ISO and IEC maintain registers of currently valid International Standards.

ISO 554:1976, *Standard atmospheres for conditioning and/or testing — Specifications*.

ISO 3772:2000, *Photography — Rolls of sensitized material for the pre-press industry — Dimensions and related requirements*.

## 3 Conditions for measurement of dimensions

The dimensions and tolerances specified in this International Standard apply at the time of manufacture, measured under atmospheric conditions of  $(23 \pm 2)$  °C and  $(50 \pm 5)$  % relative humidity as specified in ISO 554.

All measuring instrument calibrations should be conducted at a temperature of 20 °C, as specified in ISO 1, and a relative humidity of 50 %.

## 4 Film and paper dimensions

The dimensions of the film or paper and labelling shall comply with the appropriate requirements of ISO 3772.

## 5 Winding orientation

The winding configuration of the film or paper shall comply with the appropriate requirements of ISO 3772.

## 6 Dimensions of flanges

### 6.1 Rigid flange

The aim and tolerance dimensions of the internal diameter of the flange ( $A$ ), into which the machine cassette mandrel inserts, currently varies in different countries. The aim and tolerance of  $65,5_{-0,5}^0$  mm is preferred due to its tighter tolerance. However,  $65,5 \pm 0,5$  mm is recognized because it is the standard in certain countries and functions well in those locations (see Figure 1).

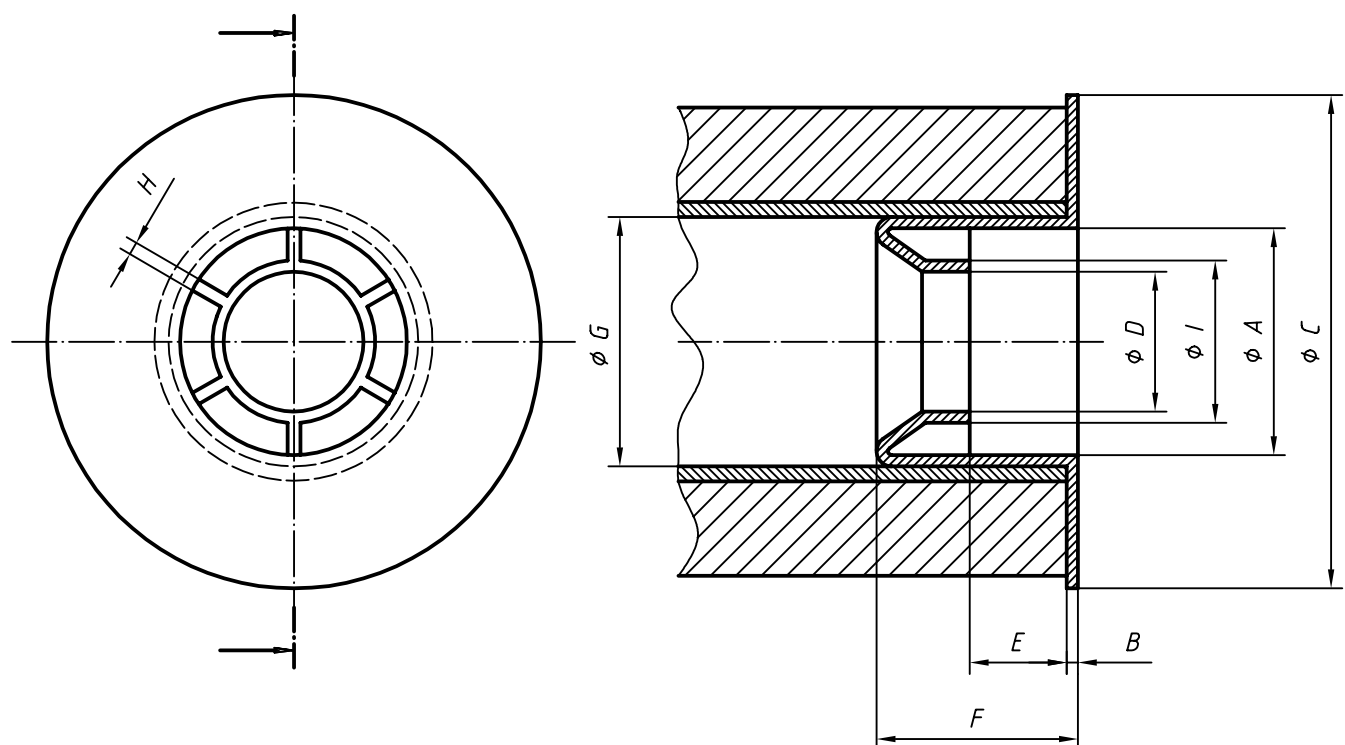

Figure 1 — Rigid flange dimensions

Dimension  $A$  applies to the mouth of the flange hole, which may have a slight taper towards the bottom of the hole in order to easily draw a (positive) mould from the plastic flange.

The thickness of the flange rim ( $B$ ) shall be  $3 \text{ mm} \pm 0,3 \text{ mm}$ , which contributes to the practical width of the roll.

The external diameter of the rim ( $C$ ), which contributes to the maximum external dimension of the spooled roll, shall be  $130,5_{-4,0}^{+0,5}$  mm such that the dimensions given in clause 7 are not exceeded (see Figure 1).

Dimension  $D$  shall be  $37 \text{ mm} \pm 0,4 \text{ mm}$ .

Dimension  $E$  shall be not less than 28,6 mm.

Dimension  $F$  shall be  $52 \text{ mm} \pm 2 \text{ mm}$ .

Rigid flanges should insert fully and securely into the film-roll core such that the flange is flush with the spooled material. Dimension  $G$  shall ensure compatibility with the cores specified in ISO 3772. Incorporation of six fins in the flange design is preferred to aid the machine wind and unwind functions.



Dimension  $H$  shall be not greater than 3,4 mm.

Dimension  $I$  shall be  $43 \text{ mm} \pm 0,5 \text{ mm}$

**CAUTION** — The maximum tolerance for dimension  $I$  is critical for proper interchangeability.

## 6.2 Flexible flange

Flanges are required for each of the preferred core sizes specified in ISO 3772.

The flanges shall be firmly attached to each end of a core which supports the roll of material and shall provide light-tight protection to the roll edges. The flanges shall not impede the winding or the unwinding of the material on the roll.

The internal diameter of the combination of the core plus any portion of the flexible flange shall comply with the minimum dimensions specified in ISO 3772:2000, 5.3.

See Figure 2 for an example of a flexible flange configuration.

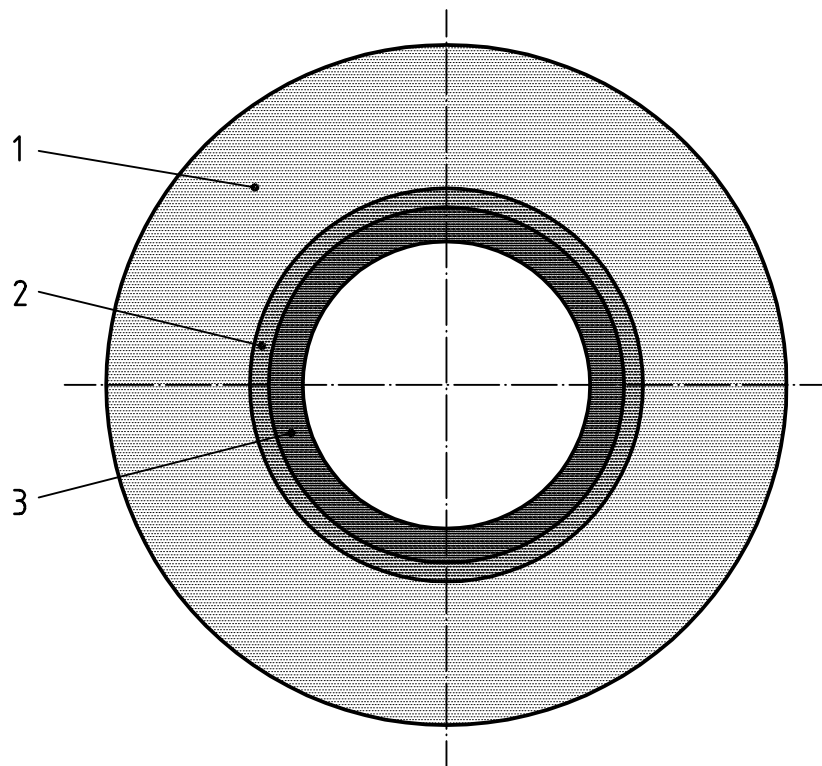

### Key

- 1 End flange
- 2 Paper core
- 3 Light-tight seal area of flange

**Figure 2** — Example of a flexible flange configuration

## 7 Packaging

### 7.1 Package width

#### 7.1.1 Rigid flange

The overall maximum width of the spooled film or paper plus room-light loading packaging, required to fit an electronic scanner or input cassette of an image-setting device, shall be up to a maximum material width + 10 mm.

#### 7.1.2 Flexible flange

The overall maximum width of the spooled film or paper plus room-light loading packaging, required to fit an electronic scanner or input cassette of an image-setting device, shall be up to a maximum material width + 2,5 mm.

### 7.2 External package diameter

The maximum external package diameter varies according to the core on which the material is wound. The core, in turn, is related to the specific equipment in use. These shall be in accordance with Table 1.

**Table 1 — Package diameter**

Dimensions in millimetres

Core internal diameter	Maximum external package diameter
28,8	96
50,7	153
71,9 <sup>a</sup>	142
<sup>a</sup> 71,9 mm cores have largely replaced 71,2 mm cores as the preferred internal diameter (ISO 3772).	

## 8 Leader

### 8.1 General requirements

The leader material is used both as the initial material feed prior to loading into the exposing device and to protect the sensitized film or paper from light.

The leader material shall be sufficiently robust and securely affixed to the film or paper to withstand the initial manual feed prior to disposal of the leader.

### 8.2 Leader width dimension

The width of the leader shall be sufficient to protect the film or paper roll from light penetration, but not hinder the initial material feed through the machine cassette opening.

### 8.3 Leader length dimension

The leader length shall be sufficient to protect the film or paper roll from light penetration, both during transit and the machine cassette loading operation.

## 8.4 Leader splicing

The total splice thickness (including the film/paper) shall not exceed 3 mm.

The width of the splicing tape shall not protrude beyond the edge of the sensitized material.

## 9 Package marking

Sufficient data shall be provided on a product's packaging to inform the user of proper use and handling.

Product packaging shall be marked so as to indicate

- product name and size,
- conditions of use (such as safelight), and
- conditions of shipping and storage.

To accomplish this, each of the packages which constitute the product's packaging should be marked so as to indicate one or more of the following:<sup>1)</sup>

- product name or trade name for unit packages; a reasonable effort shall be made to make this item legible under recommended safelight conditions;
- name or trade mark of the manufacturer;
- manufacturer's catalogue identification number;
- bar-code information;
- information to assist recycling of waste packaging;
- quantity of units contained in the package;
- product name or trade name of sensitized material;
- nominal product dimensions, in metric units, with the smaller dimension first;
- batch number and/or parent roll number;
- expiration date or "develop before" date or inventory control code;
- manufacturer's recommended safelight conditions;<sup>2)</sup>
- manufacturer's recommended storage conditions.<sup>2)</sup>

## 10 Compliance

If it is desired to indicate compliance of the room-light loading package with this International Standard, the following wording shall be used:

**"PACKAGE COMPLYING WITH ISO 14535"**

- 1) There can be legal requirements in certain countries for other data to be marked on the package.
- 2) This may be indicated by wording or by a code.

## Bibliography

- [1] ISO 1, *Geometrical Product Specifications (GPS) — Standard reference temperature for geometrical product specifications*.
- [2] ISO 11312:2000, *Photography — Sheets of sensitized material for the pre-press industry — Dimensions and related requirements*.



---

---

**ICS 37.040.20**

Price based on 6 pages

© ISO 2001 – All rights reserved