

---

---

**Optics and photonics — Test methods  
for telescopic systems —**

**Part 7:  
Test methods for limit of resolution**

*Optique et photonique — Méthodes d'essai pour systèmes  
télescopiques —*

*Partie 7: Méthodes d'essai pour limite de résolution*





**COPYRIGHT PROTECTED DOCUMENT**

© ISO 2016, Published in Switzerland

All rights reserved. Unless otherwise specified, no part of this publication may be reproduced or utilized otherwise in any form or by any means, electronic or mechanical, including photocopying, or posting on the internet or an intranet, without prior written permission. Permission can be requested from either ISO at the address below or ISO's member body in the country of the requester.

ISO copyright office  
Ch. de Blandonnet 8 • CP 401  
CH-1214 Vernier, Geneva, Switzerland  
Tel. +41 22 749 01 11  
Fax +41 22 749 09 47  
copyright@iso.org  
www.iso.org

# Contents

	Page
<b>Foreword</b> .....	<b>iv</b>
<b>Introduction</b> .....	<b>v</b>
<b>1 Scope</b> .....	<b>1</b>
<b>2 Normative references</b> .....	<b>1</b>
<b>3 Terms and definitions</b> .....	<b>1</b>
<b>4 Method of determination of the limit of resolution</b> .....	<b>1</b>
4.1 General .....	1
4.2 Test equipment .....	1
4.3 Preparation and carrying out of measurements .....	3
4.4 Determination of results .....	3
<b>5 Test report</b> .....	<b>4</b>
<b>Annex A (informative) Dimensions of a bar-type test target for determination of the limit of resolution of telescopic systems</b> .....	<b>5</b>
<b>Bibliography</b> .....	<b>10</b>

## Foreword

ISO (the International Organization for Standardization) is a worldwide federation of national standards bodies (ISO member bodies). The work of preparing International Standards is normally carried out through ISO technical committees. Each member body interested in a subject for which a technical committee has been established has the right to be represented on that committee. International organizations, governmental and non-governmental, in liaison with ISO, also take part in the work. ISO collaborates closely with the International Electrotechnical Commission (IEC) on all matters of electrotechnical standardization.

The procedures used to develop this document and those intended for its further maintenance are described in the ISO/IEC Directives, Part 1. In particular the different approval criteria needed for the different types of ISO documents should be noted. This document was drafted in accordance with the editorial rules of the ISO/IEC Directives, Part 2 (see [www.iso.org/directives](http://www.iso.org/directives)).

Attention is drawn to the possibility that some of the elements of this document may be the subject of patent rights. ISO shall not be held responsible for identifying any or all such patent rights. Details of any patent rights identified during the development of the document will be in the Introduction and/or on the ISO list of patent declarations received (see [www.iso.org/patents](http://www.iso.org/patents)).

Any trade name used in this document is information given for the convenience of users and does not constitute an endorsement.

For an explanation on the meaning of ISO specific terms and expressions related to conformity assessment, as well as information about ISO's adherence to the World Trade Organization (WTO) principles in the Technical Barriers to Trade (TBT) see the following URL: [www.iso.org/iso/foreword.html](http://www.iso.org/iso/foreword.html).

The committee responsible for this document is ISO/TC 172, *Optics and photonics*, Subcommittee SC 4, *Telescopic systems*.

This second edition cancels and replaces the first edition (ISO 14490-7:2005), which has been technically revised with the following changes:

- addition of a new sentence in [A.4](#) “Alternatively, a test pattern down to  $2^{-1/3} = 0,79$  is acceptable.”;
- corrected [Table A.2](#), last row: 302 replaced by 320.

A list of parts in the ISO 14490 series can be found on the ISO website.

## Introduction

There are various characteristics which are relevant for overall image quality of telescopic systems and observational telescopic instruments. Two important characteristics are the limit of resolution and the optical transfer function.

This document specifies the test method for the determination of the limit of resolution of telescopic systems and observational telescopic instruments. Optical transfer function measurement as applied to telescopic systems is specified in ISO 9336-3.

Besides the limit of resolution and the optical transfer function, further characteristics are relevant for an assessment of the image quality; the most important of them are the following:

- secondary spectrum (dispersive aberrations);
- distortion;
- vignetting;
- colour matching.

The secondary spectrum of the test specimen can produce colour fringes surrounding observed objects (especially at high contrast edges) which can look like coloured neon tube light.

The perceived image might have barrel or pincushion distortion. Pincushion distortion is considered to give a more natural impression of the observed object when swivelling the test specimen.

Vignetting can lead to a perceivable intensity degradation from the centre to the edge of the field of view.

Colour matching is the accuracy of the colour rendition of an object observed with the test specimen. Any colour deviation might be due to the lens material or to coatings.



# Optics and photonics — Test methods for telescopic systems —

## Part 7: Test methods for limit of resolution

### 1 Scope

This document specifies the test methods for the determination of the limit of resolution of telescopic systems and observational telescopic instruments.

### 2 Normative references

The following documents are referred to in the text in such a way that some or all of their content constitutes requirements of this document. For dated references, only the edition cited applies. For undated references, the latest edition of the referenced document (including any amendments) applies.

ISO 14490-1:2005, *Optics and optical instruments — Test methods for telescopic systems — Part 1: Test methods for basic characteristics*

### 3 Terms and definitions

For the purposes of this document, the terms and definitions given in ISO 14132-1 apply.

ISO and IEC maintain terminological databases for use in standardization at the following addresses:

- IEC Electropedia: available at <http://www.electropedia.org/>
- ISO Online browsing platform: available at <http://www.iso.org/obp>

### 4 Method of determination of the limit of resolution

#### 4.1 General

The limit of resolution of a telescopic system is the minimum angular distance between centrelines of two adjacent bright (or dark) bars of the bar-type resolution test target whose direction can be detected when viewing through the test specimen.

#### 4.2 Test equipment

The limit of resolution of telescopic systems shall be determined with the test arrangement shown in [Figure 1](#).

The bar-type resolution test target has contrast, as given by [Formula \(1\)](#):

$$K = \frac{\tau_{tr} - \tau_{op}}{\tau_{tr} + \tau_{op}} \geq 0,9 \tag{1}$$

where

$\tau_{tr}$  is the transmittance of a translucent part of the resolution test target;

$\tau_{op}$  is the transmittance of an opaque part of the resolution test target.

The resolution test target shall be placed at the focal plane of the collimator lens.

For systems that require the limit of resolution to be measured with a focus setting other than infinity, the position of the resolution test target with respect to the collimator lens shall be adjusted in order to obtain its image at the specified distance from the test specimen.

The bar-type resolution test target is a glass plate bearing a picture that consists of bright bars having different widths on a dark background, the directions of which are vertical, horizontal and diagonal in  $\pm 45$  angular degrees.

The dimensions of one acceptable design of bar-type resolution test target are given in [Annex A](#).

The resolution test target shall be illuminated uniformly (mean illuminance  $\pm 5$  % Peak to Valley) by means of a light source with a correlated colour temperature of 5 000 K to 6 000 K, condenser and diffuser for non-dazzling observation conditions. The luminance of the resolution test target shall be optimum for observation of its image.

The diameter of the collimator lens shall at least exceed 1,2 times the diameter of the entrance pupil of the test specimen. The focal length of the collimator lens shall be at least five times that of the objective of the test specimen.

The magnification of the auxiliary telescope shall not reduce the diameter of the exit pupil of the whole system below 0,8 mm.

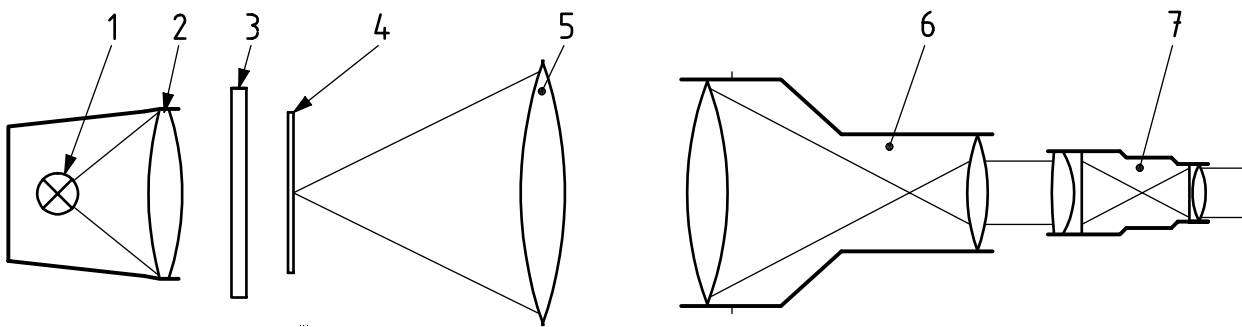

**Key**

- 1 light source
- 2 condenser
- 3 diffuser
- 4 bar-type resolution test target
- 5 collimator lens
- 6 test specimen
- 7 auxiliary telescope

The auxiliary telescope should not be used if the angular limit of resolution behind the eyepiece of the test specimen is worse than 2' to 3' and the diameter of the exit pupil is below 1 mm.

**Figure 1 — Test arrangement for measurement of the limit of resolution (schematic)**



### 4.3 Preparation and carrying out of measurements

Stray light and vibration shall be minimized (and if possible eliminated) from the test set up.

Check the cleanliness of the optical surfaces of the lenses of the test specimen, the collimator lens, the condenser, and the auxiliary telescope. No traces of lubricants, fingerprints, moisture, or dust are allowed.

Select the size number of the resolution test target according to the focal length of the collimator lens and the limit of resolution of the test specimen (for instance, see [Table A.2](#) or use the formula given for the angular resolution defined in ISO 14132).

If an auxiliary telescope is used, adjust its eyepiece according to the observer's eye to allow sharp viewing of the telescope reticle. The auxiliary telescope and the eye of the observer shall not limit the assessment of the resolution. After that, focus the auxiliary telescope on the image of the resolution test target which is located in the focal plane of the collimator lens.

Focus the test specimen on the image of the resolution test target; then position the test specimen and the auxiliary telescope coaxially with the collimator lens.

Set the eyepiece of the test specimen in a position which enables sharp viewing of the reticle of the test specimen through the auxiliary telescope. If no reticle is provided, adjust the eyepiece to zero dioptres.

Determine the limit of resolution of the test specimen in the centre of the field of view.

During observation through the eyepiece of the auxiliary telescope, the maximum sharpness of bars of a pattern at lowest sharpness in one group of the resolution test target shall be obtained by means of refocusing the test specimen. If no focusing is available in the test specimen, the maximum sharpness of bars of a pattern at lowest sharpness in one group of the resolution test target shall be obtained by refocusing the auxiliary telescope.

During successive viewing of images of certain groups of the resolution test target having different spatial frequencies, a group of the resolution test target shall be found which enables easy detection of all four bar directions. This shall be achieved without refocusing for the different bar directions. This group shall be located in the centre of the field of view of the test specimen.

### 4.4 Determination of results

From the size number of the resolution test target group that enables the detection of all four pattern directions, determine the bar width,  $b$ .

Calculate the angular distance,  $\varphi$ , in seconds of angle, between the centrelines of adjacent bright (or dark) bars of each resolution test target group according to [Formula \(2\)](#):

$$\varphi = \frac{2b}{f'_k} \times 206\,265 \quad (2)$$

where

$b$  is the bar width, in mm;

$f'_k$  is the focal length of the collimator lens, in mm;

206 265 is the number of arc seconds/radian.

## 5 Test report

A test report shall be presented and shall include the general information specified in ISO 14490-1:2005, Clause 13, the result of the test as specified in [4.4](#) above and information on the test target used for the test.

## Annex A (informative)

### Dimensions of a bar-type test target for determination of the limit of resolution of telescopic systems

#### A.1 Resolution test target layout

The resolution test target consists of 25 groups, as shown in [Figure A.1](#), and two pairs of parallel, equally spaced marks. The distance between the centres of the marks that defines the size of the test target is called the test target base.

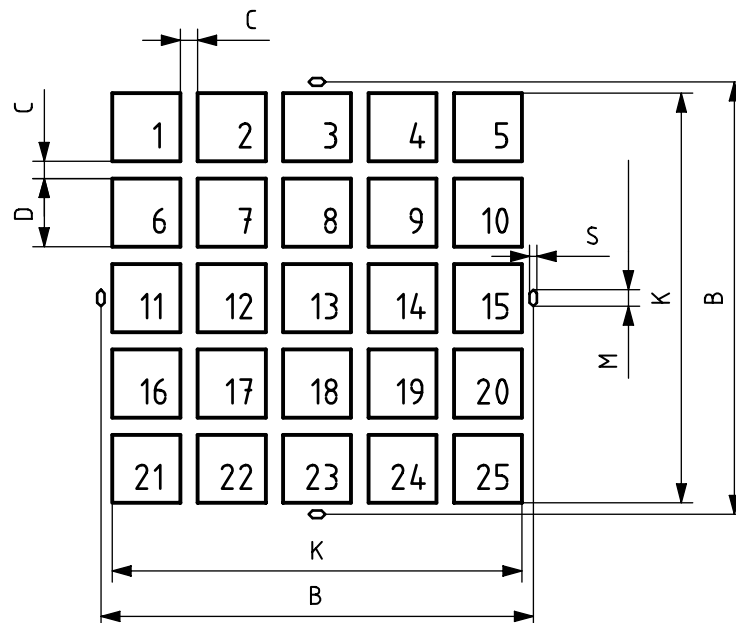

NOTE Dimensions of resolution test targets are given in [Table A.1](#).

Figure A.1 — Resolution test target layout

#### A.2 Layout of groups of resolution test target

Each group of the resolution test target consists of four patterns formed by five bars each. The bars have equal lengths and widths and are arranged as shown in [Figure A.2](#). The intervals between adjacent bars are equal to the bar width.

**A.3 Dimensions**

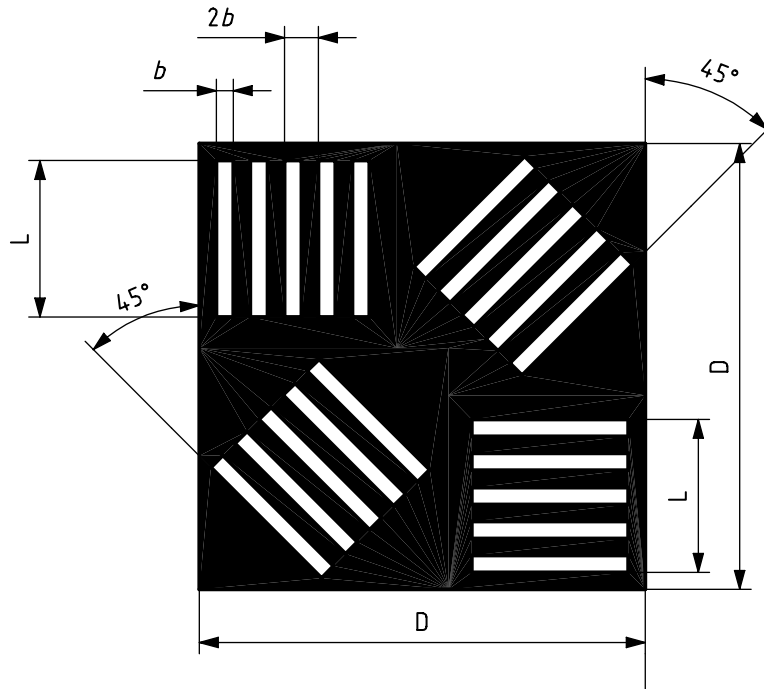

NOTE Dimensions of resolution test targets are given in [Table A.1](#).

**Figure A.2 — Group of the resolution test target**

**A.4 Bar width**

The bar width,  $b$ , in the resolution test target shall decrease from the group no. 1 to the group no. 25 in accordance with the geometric progression having the base  $2^{-1/12} = 0,94$ . Alternatively, a test pattern down to  $2^{-1/3} = 0,79$  is acceptable.

NOTE See [Table A.1](#) for dimensions.

**A.5 Number of bars**

The number,  $N$ , of bars per millimetre for any test target group number should be determined by division of 1 000  $\mu\text{m}$  by the distance between the centrelines of adjacent bright (or dark) bars ( $2b$ ) in  $\mu\text{m}$ .

**Table A.1 — Dimensions of resolution test targets**

Dimensions in millimetres

Designation <sup>a</sup>	Test target number					
	1	2	3	4	5	6
B	1,2	2,4	4,8	9,6	19,2	38,4
D	0,2	0,4	0,9	1,7	3,5	7,0
C	0,01	0,02	0,04	0,08	0,16	0,32
K	1,1	2,3	4,5	9,1	18,2	36,4

<sup>a</sup> See [Figure A.1](#) and [Figure A.2](#).

Table A.1 (continued)

Designation <sup>a</sup>	Test target number					
	1	2	3	4	5	6
M	0,05	0,1	0,2	0,4	0,8	1,6
S	0,005	0,01	0,02	0,04	0,08	0,16
L	0,09	0,18	0,36	0,72	1,44	2,88

<sup>a</sup> See [Figure A.1](#) and [Figure A.2](#).

## A.6 Angular distance between centrelines of adjacent bars

The angular distance,  $\varphi$ , in seconds of angle, between the centrelines of adjacent bright (or dark) bars of each resolution test target group is calculated in accordance with [Formula \(2\)](#).

The values of the angular distance,  $\varphi$ , which depend on the focal length of the collimator objective,  $f'_k$  and the number of bars,  $N$ , for the test target specified in this annex are given in [Table A.2](#).

Table A.2 — Values of the angular distance,  $\varphi$ , for the test target specified in [A.1](#) to [A.5](#)

Numbers of target groups for a test target number						Bar width $b$	Bars $N$	Angular distance, $\varphi$ , between the middles of adjacent bars for a given collimator focal length, $f'_k$ in seconds						
Test target number								$f'_k$ mm						
1	2	3	4	5	6	$\mu\text{m}$	bars/mm	600	1 000	1 200	1 600	2 500	3 000	5 000
25	—	—	—	—	—	2,5	200	1,72	1,03	0,88	0,64	0,41	0,34	0,20
24	—	—	—	—	—	2,6	190	1,82	1,09	0,91	0,68	0,44	0,36	0,22
23	—	—	—	—	—	2,8	180	1,93	1,16	0,96	0,72	0,46	0,38	0,23
22	—	—	—	—	—	3,0	170	2,04	1,23	1,02	0,76	0,49	0,40	0,25
21	—	—	—	—	—	3,1	160	2,16	1,30	1,08	0,81	0,52	0,43	0,26
20	—	—	—	—	—	3,3	150	2,29	1,38	1,15	0,86	0,55	0,46	0,28
19	—	—	—	—	—	3,5	140	2,43	1,46	1,22	0,91	0,58	0,49	0,29
18	—	—	—	—	—	3,7	130	2,58	1,54	1,29	0,96	0,62	0,51	0,31
17	—	—	—	—	—	4,0	125	2,73	1,63	1,37	1,02	0,65	0,54	0,33
16	—	—	—	—	—	4,2	120	2,89	1,73	1,45	1,08	0,70	0,57	0,35
15	—	—	—	—	—	4,5	110	3,06	1,83	1,53	1,15	0,74	0,61	0,37
14	—	—	—	—	—	4,7	105	3,24	1,94	1,62	1,22	0,78	0,65	0,38
13	25	—	—	—	—	5,0	100	3,44	2,06	1,72	1,29	0,82	0,69	0,41
12	24	—	—	—	—	5,3	95	3,64	2,18	1,82	1,36	0,87	0,73	0,44
11	23	—	—	—	—	5,6	90	3,86	2,31	1,93	1,44	0,92	0,77	0,46
10	22	—	—	—	—	5,9	85	4,08	2,45	2,04	1,52	0,98	0,82	0,49
9	21	—	—	—	—	6,3	80	4,33	2,60	2,16	1,62	1,04	0,87	0,52
8	20	—	—	—	—	6,7	75	4,58	2,76	2,29	1,72	1,10	0,92	0,55
7	19	—	—	—	—	7,1	70	4,86	2,92	2,43	1,82	1,16	0,97	0,58
6	18	—	—	—	—	7,5	65	5,16	3,08	2,58	1,92	1,24	1,02	0,62
5	17	—	—	—	—	7,9	63	5,46	3,26	2,73	2,04	1,32	1,08	0,66
4	16	—	—	—	—	8,4	60	5,78	3,46	2,90	2,16	1,40	1,14	0,70

Table A.2 (continued)

Numbers of target groups for a test target number						Bar width <i>b</i>	Bars <i>N</i>	Angular distance, $\varphi$ , between the middles of adjacent bars for a given collimator focal length, $f'_k$ in seconds						
Test target number						$\mu\text{m}$	bars/ mm	$f'_k$ mm						
1	2	3	4	5	6			600	1 000	1 200	1 600	2 500	3 000	5 000
3	15	—	—	—	—	8,9	56	6,12	3,65	3,06	2,30	1,48	1,22	0,74
2	14	—	—	—	—	9,4	53	6,48	3,88	3,24	2,44	1,56	1,30	0,78
1	13	25	—	—	—	10,0	50	6,88	4,12	3,44	2,58	1,64	1,38	0,82
—	12	24	—	—	—	10,6	47	7,28	4,35	3,64	2,72	1,74	1,46	0,87
—	11	23	—	—	—	11,2	45	7,72	4,62	3,86	2,83	1,84	1,54	0,92
—	10	22	—	—	—	11,9	42	8,16	4,90	4,08	3,04	1,96	1,64	0,98
—	9	21	—	—	—	12,6	40	8,64	5,20	4,32	3,24	2,08	1,74	1,04
—	8	20	—	—	—	13,3	38	9,16	5,52	4,58	3,44	2,20	1,84	1,10
—	7	19	—	—	—	14,1	35	9,72	5,84	4,86	3,64	2,32	1,94	1,16
—	6	18	—	—	—	15,0	33	10,32	6,16	5,16	3,84	2,48	2,04	1,24
—	5	17	—	—	—	15,9	32	10,92	6,52	5,46	4,08	2,64	2,16	1,32
—	4	16	—	—	—	16,8	30	11,56	6,92	5,80	4,32	2,80	2,28	1,40
—	3	15	—	—	—	17,8	28	12,24	7,32	6,12	4,60	2,96	2,44	1,48
—	2	14	—	—	—	18,9	26	12,96	7,76	6,48	4,88	3,12	2,60	1,56
—	1	13	25	—	—	20,0	25	13,76	8,24	6,88	5,16	3,28	2,76	1,64
—	—	12	24	—	—	21,2	24	14,56	8,72	7,28	5,44	3,48	2,92	1,74
—	—	11	23	—	—	22,5	22	15,44	9,24	7,72	5,76	3,68	3,08	1,84
—	—	10	22	—	—	23,8	21	16,32	9,80	8,16	6,08	3,92	3,28	1,96
—	—	9	21	—	—	25,2	20	17,28	10,40	8,64	6,48	4,16	3,48	2,08
—	—	8	20	—	—	26,7	19	18,32	11,04	9,16	6,88	4,40	3,68	2,20
—	—	7	19	—	—	28,3	18	19,44	11,68	9,72	7,28	4,64	3,88	2,32
—	—	6	18	—	—	30,0	17	20,64	12,32	10,28	7,68	4,96	4,08	2,48
—	—	5	17	—	—	31,7	16	21,84	13,04	10,92	8,16	5,28	4,32	2,64
—	—	4	16	—	—	33,6	15	23,12	13,84	11,60	8,64	5,60	4,56	2,80
—	—	3	15	—	—	35,6	14	24,48	14,64	12,24	9,20	5,92	4,88	2,96
—	—	2	14	—	—	37,8	13	25,92	15,52	12,96	9,76	6,24	5,20	3,12
—	—	1	13	25	—	40,0	12,5	27,52	16,48	13,76	10,32	6,56	5,52	3,28
—	—	—	12	24	—	42,4	12	—	17,44	14,56	10,88	6,96	5,84	3,48
—	—	—	11	23	—	44,9	11	—	18,48	15,44	11,52	7,36	6,16	3,68
—	—	—	10	22	—	47,6	10,5	—	19,60	16,32	12,16	7,84	6,56	3,92
—	—	—	9	21	—	50,4	10	—	20,80	17,28	12,96	8,32	6,94	4,16
—	—	—	8	20	—	53,4	9,4	—	21,9	18,3	13,7	8,8	7,4	4,4
—	—	—	7	19	—	56,6	9	—	23,3	19,4	14,5	9,3	7,9	4,7
—	—	—	6	18	—	59,9	8,4	—	24,6	20,7	15,4	9,9	8,3	4,9
—	—	—	5	17	—	63,5	8	—	26,18	21,8	16,3	10,5	8,8	5,2
—	—	—	4	16	—	67,3	7,4	—	27,7	23,2	17,2	11,1	9,3	5,6
—	—	—	3	15	—	71,3	7	—	29,4	24,7	18,3	11,8	9,8	5,9

Table A.2 (continued)

Numbers of target groups for a test target number						Bar width $b$	Bars $N$	Angular distance, $\varphi$ , between the middles of adjacent bars for a given collimator focal length, $f'_k$ in seconds						
Test target number						$\mu\text{m}$	bars/ mm	$f'_k$ mm						
1	2	3	4	5	6			600	1 000	1 200	1 600	2 500	3 000	5 000
—	—	—	2	14	—	75,5	6,6	—	31,1	25,9	19,4	12,4	10,4	6,2
—	—	—	1	13	25	80,0	6,3	—	32,9	27,4	20,5	13,2	11,0	6,6
—	—	—	—	12	24	84,8	6	—	—	—	—	14,0	11,7	7,0
—	—	—	—	11	23	89,8	5,5	—	—	—	—	14,8	12,4	7,4
—	—	—	—	10	22	95,2	5,2	—	—	—	—	15,7	13,2	7,8
—	—	—	—	9	21	100,8	5	—	—	—	—	16,6	13,9	8,3
—	—	—	—	8	20	106,8	4,7	—	—	—	—	17,6	14,7	8,8
—	—	—	—	7	19	113,2	4,5	—	—	—	—	18,7	15,6	9,4
—	—	—	—	6	18	119,8	4,2	—	—	—	—	19,7	16,5	9,8
—	—	—	—	5	17	127,0	4	—	—	—	—	20,9	17,5	10,5
—	—	—	—	4	16	134,6	3,7	—	—	—	—	22,1	18,6	11,1
—	—	—	—	3	15	142,6	3,5	—	—	—	—	23,5	19,7	11,8
—	—	—	—	2	14	151	3,3	—	—	—	—	24,9	20,8	12,5
—	—	—	—	1	13	160	3,1	—	—	—	—	26,4	22,1	13,2
—	—	—	—	—	12	170	2,9	—	—	—	—	—	—	14,0
—	—	—	—	—	11	180	2,8	—	—	—	—	—	—	14,8
—	—	—	—	—	10	189	2,7	—	—	—	—	—	—	15,6
—	—	—	—	—	9	202	2,5	—	—	—	—	—	—	16,7
—	—	—	—	—	8	214	2,3	—	—	—	—	—	—	17,7
—	—	—	—	—	7	227	2,2	—	—	—	—	—	—	18,7
—	—	—	—	—	6	240	2,0	—	—	—	—	—	—	19,8
—	—	—	—	—	5	253	1,97	—	—	—	—	—	—	20,8
—	—	—	—	—	4	269	1,86	—	—	—	—	—	—	22,2
—	—	—	—	—	3	285	1,75	—	—	—	—	—	—	23,5
—	—	—	—	—	2	301	1,66	—	—	—	—	—	—	24,8
—	—	—	—	—	1	320	1,56	—	—	—	—	—	—	26,4

## Bibliography

- [1] ISO 9336-3, *Optics and optical instruments — Optical transfer function — Application — Part 3: Telescopes*
- [2] ISO 14132-1, *Optics and photonics — Vocabulary for telescopic systems — Part 1: General terms and alphabetical indexes of terms in ISO 14132*





