**Optics and photonics — Test methods
for telescopic systems —**

**Part 3:
Test methods for telescopic sights**

*Optique et photonique — Méthodes d'essai pour systèmes
télescopiques —*

Partie 3: Méthodes d'essai pour viseurs de tir



COPYRIGHT PROTECTED DOCUMENT

© ISO 2016, Published in Switzerland

All rights reserved. Unless otherwise specified, no part of this publication may be reproduced or utilized otherwise in any form or by any means, electronic or mechanical, including photocopying, or posting on the internet or an intranet, without prior written permission. Permission can be requested from either ISO at the address below or ISO's member body in the country of the requester.

ISO copyright office
Ch. de Blandonnet 8 • CP 401
CH-1214 Vernier, Geneva, Switzerland
Tel. +41 22 749 01 11
Fax +41 22 749 09 47
copyright@iso.org
www.iso.org

Contents

Page

Foreword	v
1 Scope	1
2 Normative references	1
3 Terms and definitions	1
4 Method of measurement of axial parallax	1
4.1 Principle.....	1
4.2 Test arrangement.....	2
4.2.1 General.....	2
4.2.2 Collimator.....	2
4.2.3 Telescopic sight.....	2
4.2.4 Dioptric tester.....	2
4.3 Measurement procedure.....	3
4.4 Test report.....	3
5 Method of measurement of parallax	3
5.1 Principle.....	3
5.2 Test arrangement.....	3
5.2.1 General.....	3
5.2.2 Collimator.....	4
5.2.3 Telescopic sight.....	4
5.2.4 Light stop.....	4
5.2.5 Auxiliary telescope.....	4
5.3 Measurement procedure.....	5
5.4 Test report.....	6
6 Method of measurement of eye relief range	6
6.1 Principle.....	6
6.2 Test arrangement.....	6
6.2.1 General.....	6
6.2.2 Collimator.....	6
6.2.3 Telescopic sight.....	6
6.2.4 Measuring magnifier.....	6
6.3 Measurement procedure.....	7
6.4 Test report.....	8
7 Method of measurement of reticle tracking	8
7.1 Principle.....	8
7.2 Test arrangement.....	8
7.2.1 General.....	8
7.2.2 Collimator.....	8
7.3 Test procedure.....	9
7.4 Test report.....	9
8 Method of measurement of line of sight shift due to zooming	9
8.1 Principle.....	9
8.2 Test arrangement.....	9
8.2.1 General.....	9
8.2.2 Test specimen mounting.....	11
8.2.3 Auxiliary telescope.....	11
8.3 Test procedure.....	11
8.3.1 Preparation of the test assembly.....	11
8.3.2 Determination of the measurement values.....	11
8.4 Precision of the measurement.....	12
8.5 Test report.....	12
9 Method of measurement of line of sight shift due to focusing	12

9.1	Principle.....	12
9.2	Test arrangement.....	12
9.2.1	General.....	12
9.2.2	Collimator	13
9.2.3	Telescopic sight.....	14
9.2.4	Auxiliary telescope.....	14
9.3	Test procedure.....	14
9.3.1	Preparation of the test assembly.....	14
9.3.2	Determination of the measurement values.....	14
9.4	Precision of the measurement.....	14
9.5	Test report.....	15
10	General test report.....	15

Foreword

ISO (the International Organization for Standardization) is a worldwide federation of national standards bodies (ISO member bodies). The work of preparing International Standards is normally carried out through ISO technical committees. Each member body interested in a subject for which a technical committee has been established has the right to be represented on that committee. International organizations, governmental and non-governmental, in liaison with ISO, also take part in the work. ISO collaborates closely with the International Electrotechnical Commission (IEC) on all matters of electrotechnical standardization.

The procedures used to develop this document and those intended for its further maintenance are described in the ISO/IEC Directives, Part 1. In particular the different approval criteria needed for the different types of ISO documents should be noted. This document was drafted in accordance with the editorial rules of the ISO/IEC Directives, Part 2 (see www.iso.org/directives).

Attention is drawn to the possibility that some of the elements of this document may be the subject of patent rights. ISO shall not be held responsible for identifying any or all such patent rights. Details of any patent rights identified during the development of the document will be in the Introduction and/or on the ISO list of patent declarations received (see www.iso.org/patents).

Any trade name used in this document is information given for the convenience of users and does not constitute an endorsement.

For an explanation on the meaning of ISO specific terms and expressions related to conformity assessment, as well as information about ISO's adherence to the WTO principles in the Technical Barriers to Trade (TBT) see the following URL: [Foreword - Supplementary information](#).

The committee responsible for this document is ISO/TC 172, *Optics and photonics*, Subcommittee SC 4, *Telescopic systems*.

This second edition cancels and replaces the first edition (ISO 14490-3:2004), which has been technically revised with the following changes:

- a) [Clause 9](#) "Method of measurement of line of sight shift due to focusing" was added;
- b) the term "magnification" was replaced by "magnifying power" in various instances.

ISO 14490 consists of the following parts, under the general title *Optics and photonics — Test methods for telescopic systems*:

- *Part 1: Test methods for basic characteristics*
- *Part 2: Test methods for binocular systems*
- *Part 3: Test methods for telescopic sights*
- *Part 4: Test methods for astronomical telescopes*
- *Part 5: Test methods for transmittance*
- *Part 6: Test methods for veiling glare index*
- *Part 7: Test methods for limit of resolution*
- *Part 8: Test methods for night-vision devices*

Optics and photonics — Test methods for telescopic systems —

Part 3: Test methods for telescopic sights

1 Scope

This part of ISO 14490 specifies test equipment and test procedures for determination of the following optical characteristics of telescopic sights:

- axial parallax;
- parallax;
- eye relief range;
- reticle tracking;
- line of sight shift due to zooming;
- line of sight shift due to focusing.

2 Normative references

The following documents, in whole or in part, are normatively referenced in this document and are indispensable for its application. For dated references, only the edition cited applies. For undated references, the latest edition of the referenced document (including any amendments) applies.

ISO 14132-1, *Optics and photonics — Vocabulary for telescopic systems — Part 1: General terms and alphabetical indexes of terms in ISO 14132*

ISO 14132-3, *Optics and photonics — Vocabulary for telescopic systems — Part 3: Terms for telescopic sights*

ISO 14135-1:2014, *Optics and photonics — Specifications for telescopic sights — Part 1: General-purpose instruments*

ISO 14135-2:2014, *Optics and photonics — Specifications for telescopic sights — Part 2: High-performance instruments*

3 Terms and definitions

For the purposes of this document, the terms and definitions given in ISO 14132-1 and ISO 14132-3 apply.

4 Method of measurement of axial parallax

4.1 Principle

This test method describes the measurement of the axial distance between the reticle of a telescopic sight and an image, formed by the objective lens of this telescopic sight (where the reticle is in the first image plane) or by the objective lens and erecting system (where the reticle is in the second image

plane). The distance between the reticle of the telescopic sight and image plane of the collimator reticle along the optical axis p'_{ax} is expressed in dioptries (m^{-1}) and measured with the auxiliary telescope.

4.2 Test arrangement

4.2.1 General

Measurement of the axial parallax shall be carried out with the test arrangement shown in [Figure 1](#).

It shall be possible to adjust the alignment of the collimator and the telescopic sight relative to each other. This can be achieved by adjusting the collimator and/or the telescopic sight.

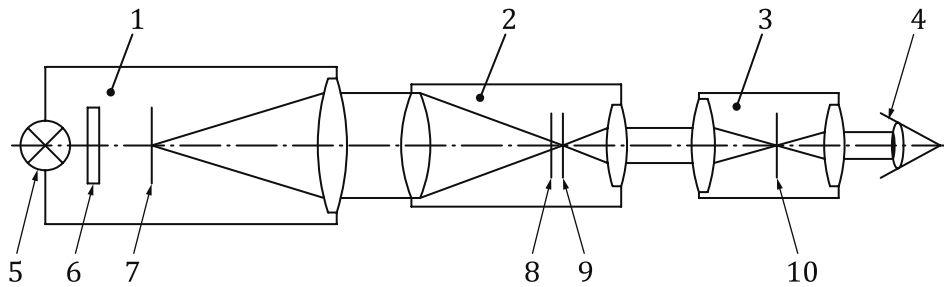

Key

- | | |
|---------------------|-------------------------------------|
| 1 collimator | 6 filter |
| 2 telescopic sight | 7 reticle of collimator |
| 3 dioptic tester | 8 reticle of telescopic sight |
| 4 observer's eye | 9 image plane of collimator reticle |
| 5 illumination unit | 10 reticle of dioptic tester |

Figure 1 — Test arrangement for measuring axial parallax

4.2.2 Collimator

The collimator shall have a useful diameter larger than the objective lens diameter of the telescopic sight under test and a focal length of at least ten times the diameter of the collimator lens.

The reticle of the collimator should have geometric features appropriate to assess the offset, e.g. a cross-hair. The axial position of this reticle shall be correctly adjusted to form an image at the specified parallax-free distance of the telescopic sight under test.

The illumination unit shall create a uniform brightness over the aperture of the collimator.

To avoid chromatic aberrations, a green filter (approximately $0,55 \mu m$) shall be used.

4.2.3 Telescopic sight

The telescopic sight and/or the collimator shall be adjusted relative to each other so that both optical axes are parallel and in such a position that the objective lens of the telescopic sight is completely illuminated.

The centre of the reticle of the telescopic sight shall be near the optical axis of the sight.

4.2.4 Dioptic tester

The dioptic tester shall have an aperture larger than the exit pupil of the telescopic sight and a magnifying power sufficient to ensure a precise measurement (i.e. $\times 3$ to $\times 6$).

4.3 Measurement procedure

Set the dioptric tester to zero with its eyepiece adjusted to obtain a sharp image of its own reticle.

The eyepiece of the telescopic sight shall be focused on the reticle of the telescopic sight to obtain a sharp image while viewing through the dioptric tester.

For telescopic sights with fixed eyepiece, use the dioptric tester to focus on the reticle of the telescopic sight.

The dioptric setting of the dioptric tester shall be adjusted to obtain a sharp image of the collimator reticle.

The axial parallax in the image space, p'_{ax} , shall be determined by the difference of the two readings on the dioptric tester.

The uncertainty of measurement for p'_{ax} (expressed in m^{-1}) shall not exceed Formula (1):

$$\frac{2,7 \text{ m}}{10^6 \cdot D'^2} \quad (1)$$

where D' is the exit pupil diameter of the telescopic sight expressed in metres.

For exit pupil diameters larger than 7 mm, the value in the formula shall be $D' = 7 \text{ mm}$.

The axial parallax in the object space, p_{ax} , is calculated as given in Formula (2):

$$p_{ax} = \frac{p'_{ax}}{\Gamma^2} \quad (2)$$

where Γ is the magnifying power of the telescopic sight under test.

NOTE The image quality of the test setup (including the telescopic sight under test) influences the measurement error.

4.4 Test report

A test report shall be presented and shall include the general information specified in [Clause 10](#) and the result of the test as specified in [4.3](#).

5 Method of measurement of parallax

5.1 Principle

This method describes the determination of the angular deviation between the aiming lines for on-axis and off-axis observation.

NOTE For exit pupil diameters of approximately 2 mm or less, only the test method for axial parallax is appropriate.

5.2 Test arrangement

5.2.1 General

Measurement of the parallax shall be carried out with the test arrangement shown in [Figure 2](#).

It shall be possible to adjust the alignment of the collimator and the telescopic sight relative to each other. This can be achieved by adjusting the collimator and/or the telescopic sight.

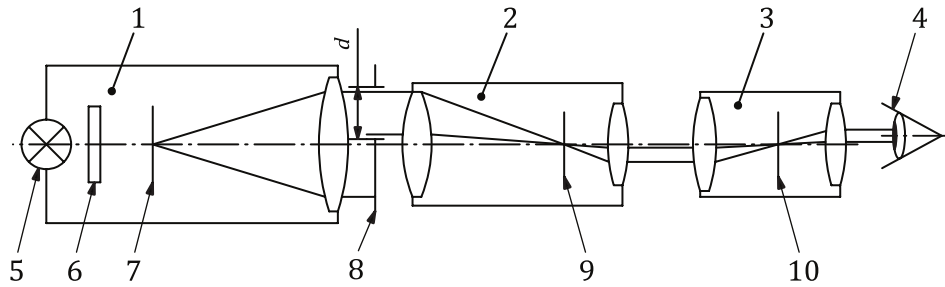

Key

1	collimator	6	filter
2	telescopic sight	7	reticle of collimator
3	auxiliary telescope	8	light stop, off-axis
4	observer's eye	9	reticle of telescopic sight
5	illumination unit	10	reticle of auxiliary telescope

Figure 2 — Test arrangement for measuring parallax

5.2.2 Collimator

The collimator shall have a useful diameter larger than the objective lens diameter of the telescopic sight under test and a focal length of at least ten times the diameter of the collimator lens.

The reticle of the collimator should have geometric features appropriate to assess the offset, e.g. a cross-hair. The axial position of this reticle shall be correctly adjusted to form an image at the specified parallax-free distance of the telescopic sight under test.

The illumination unit shall create a uniform brightness over the aperture of the collimator. To avoid chromatic aberrations, a green filter (approximately 0,55 μm) shall be used.

5.2.3 Telescopic sight

The telescopic sight and/or the collimator shall be adjusted relative to each other so that both optical axes are parallel and in such a position that the objective lens of the telescopic sight is completely illuminated.

The centre of the reticle of the telescopic sight shall be near the optical axis of the sight.

5.2.4 Light stop

The light stop shall have a diameter, *d*, in millimetres, (see [Figure 2](#)) of $d = (1,2 \pm 0,1) \Gamma$ where Γ is the magnifying power of the telescopic sight under test.

The light stop shall be adjustable in a horizontal direction over the whole diameter of the entrance pupil of the telescopic sight.

5.2.5 Auxiliary telescope

The auxiliary telescope shall have an aperture larger than the exit pupil of the telescopic sight and a magnification sufficient to ensure a precise measurement.

The auxiliary telescope reticle shall have a scale in minutes of arc on its horizontal axis, with subdivisions of at most 2 minutes of arc (MOA).

The auxiliary telescope shall be focused to infinity.

5.3 Measurement procedure

The eyepiece of the telescopic sight shall be focused on the reticle of the telescopic sight to obtain a sharp image while viewing through the auxiliary telescope.

Adjust the light stop to two opposite positions, so that in each of them, its outer edge corresponds to the edge of the entrance pupil of the telescopic sight.

Use the auxiliary telescope to determine the change, α , in MOA, of the angular deviation between the images of the collimator reticle and the telescopic sight reticle in the two light stop positions (see [Figure 3](#)).

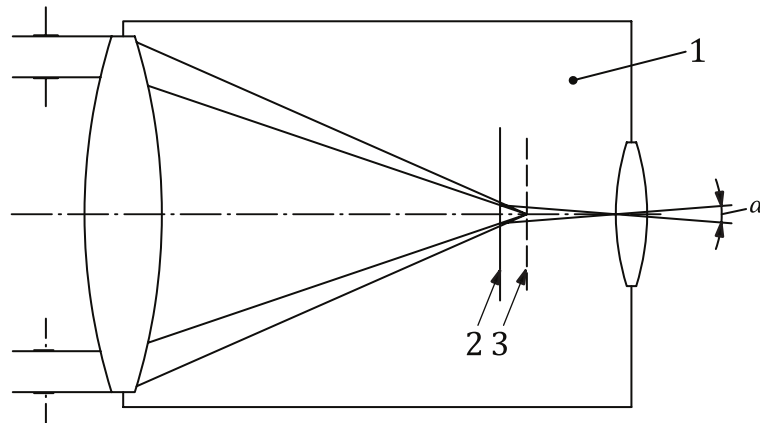

Key

- 1 telescopic sight
- 2 reticle of telescopic sight
- 3 image plane of collimator reticle
- α change, in MOA, of the angular deviation between the images of the collimator reticle and the telescopic sight reticle in the two light stop positions

Figure 3 — Explanation of measurement of quantity α

The parallax p' in the image space is calculated as given in Formula (3):

$$p' = \frac{\alpha}{2} \quad (3)$$

The maximum parallax in the object space p is calculated as given in Formula (4):

$$p = \frac{p'}{\Gamma} \quad (4)$$

where Γ is the magnifying power of the telescopic sight under test.

The uncertainty of measurement for p' shall not exceed 1,0 MOA.

NOTE For practical purposes, the relations between parallax and axial parallax are given by the following formulae:

$$p' = p'_{ax} \frac{D'}{2}, \text{ expressed in milliradians}$$

$$p' = p'_{ax} \frac{D'}{2} \times 3,438, \text{ expressed in minutes of arc}$$

where D' is the exit pupil diameter, expressed in millimetres.

5.4 Test report

A test report shall be presented and shall include the general information specified in [Clause 10](#) and the result of the test as specified in [5.3](#).

6 Method of measurement of eye relief range

6.1 Principle

This method describes the determination of that eye position range along the optical axis of a telescopic sight, which still allows observation of the full field of view.

For this method, a mean daylight eye pupil of 3 mm in diameter is assumed.

For an illustration of eye relief range, see [Figure 4](#). For documentation purposes, the eye relief range is given as “ d_{\min} to d_{\max} ”.

6.2 Test arrangement

6.2.1 General

Measurement of the eye relief range shall be carried out with the test arrangement shown in [Figure 4](#).

It shall be possible to adjust the alignment of the collimator and the telescopic sight relative to each other. This can be achieved by adjusting the collimator and/or the telescopic sight.

6.2.2 Collimator

The collimator shall have a useful diameter larger than that of the objective lens of the telescopic sight under test and a focal length of at least ten times the diameter of the collimator lens.

The collimator shall have two point-shaped light sources positioned in the focal plane of the collimator. In the case of a telescopic sight without parallax adjustment, the two point-shaped light sources shall be positioned in such way that their images appear in the parallax-free distance. These light sources shall be adjustable symmetrically about the optical axis in correspondence to the field of view of the telescopic sight.

To avoid chromatic aberration, a green filter (approximately 0,55 μm) shall be used.

6.2.3 Telescopic sight

The reticle of the telescopic sight shall be near the optical axis of the sight. The telescopic sight shall be adjustable relative to the collimator around two mutually orthogonal axes lying in a plane perpendicular to the optical axis.

6.2.4 Measuring magnifier

The measuring magnifier should have a magnifying power of approximately ten times and a reticle with a graduation of 0,1 mm. The graduated side of the reticle is positioned as close to the diffusing surface of the screen as possible.

The optical axis of the measuring magnifier is positioned parallel to the optical axis of the telescopic sight and adjustable in the axial direction.

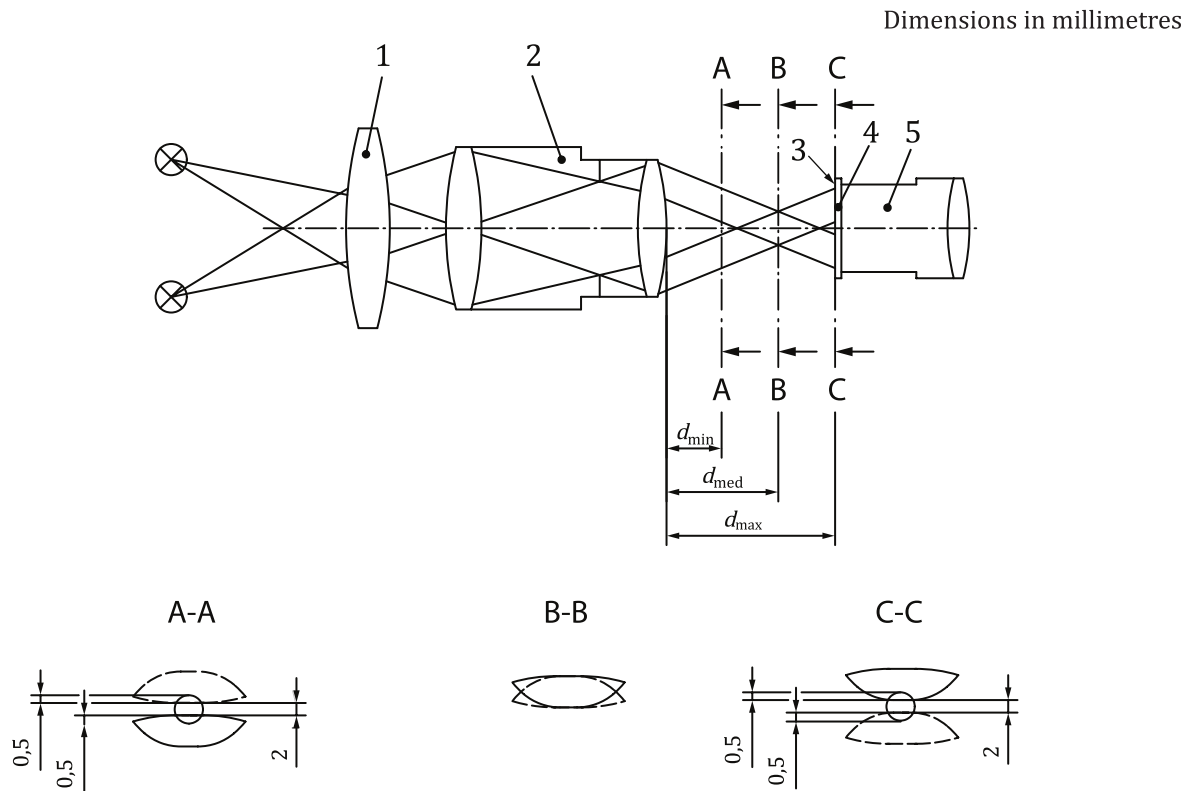
**Key**

- 1 collimator
- 2 telescopic sight
- 3 diffusing screen
- 4 glass with scale
- 5 measuring magnifier

NOTE Sectional views A-A, B-B and C-C show appearance of ray bundles at distances d_{\min} , d_{med} and d_{\max} , respectively.

Figure 4 — Test arrangement for measuring eye relief range

6.3 Measurement procedure

Adjust the distance between the two light sources of the collimator corresponding to the field of view of the telescopic sight under test.

Align the telescopic sight so that the edge line of the field of view corresponds with the images of the two light sources.

Move the measuring magnifier, starting from a position close to the telescopic sight, along the optical axis until the inner edges of the two ray bundles are at a distance of 2 mm (see [Figure 4](#), section A-A).

In this position, 0,5 mm of the meridional extension of each of the two ray bundles are covered by a mean daylight eye pupil of 3 mm in diameter.

This position represents the lower limit of the eye relief range.

Continue moving the measuring magnifier along the optical axis until the inner edges of the two ray bundles again are at a distance of 2 mm (see [Figure 4](#), section C-C).

This position represents the upper limit of the eye relief range.

The values for the upper and lower limits of the eye relief range are given by the distances in millimetres from the vertex of the last optical surface of the telescopic sight to the graduated surface of the measuring magnifier in both of the above defined positions.

The uncertainty of measurement shall be less than 0,4 mm for each distance and less than 0,8 mm for the eye relief range.

6.4 Test report

A test report shall be presented and shall include the general information specified in [Clause 10](#) and the result of the test as specified in [6.3](#).

7 Method of measurement of reticle tracking

7.1 Principle

This method describes how to check the movement of the aiming mark over the total adjustment range in relation to the reticle axes.

7.2 Test arrangement

7.2.1 General

The test equipment consists of a collimator and a fixture for the telescopic sight under test in front of the collimator. The telescopic sight shall be adjustable relative to the collimator around two mutually orthogonal axes lying in a plane perpendicular to the optical axis.

In order to avoid misalignment between the collimator and the telescopic sight when controls on the latter are actuated, it may be advisable to keep the telescopic sight rigidly mounted in a sturdy stationary fixture while making the adjustments necessary to accomplish correct alignment by moving the collimator.

7.2.2 Collimator

The collimator shall have a useful diameter larger than that of the objective lens of the telescopic sight under test and a focal length of at least ten times the diameter of the collimator lens.

The reticle of the collimator shall be as shown in [Figure 5](#). The axial position of this reticle shall be correctly adjusted to form a virtual image at the specified parallax-free distance of the telescopic sight under test.

The field of view of the collimator shall be greater than or equal to the total reticle adjustment range of the telescopic sight under test.

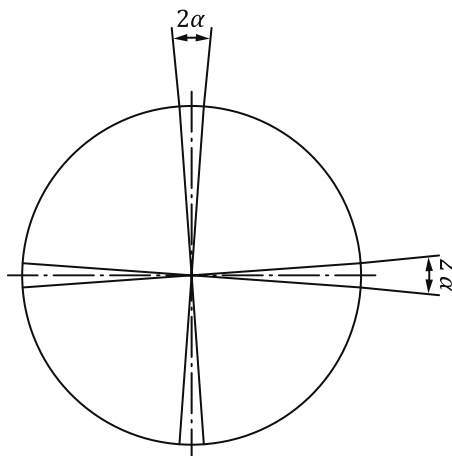
**Key**

α angular tolerance, in degrees

Figure 5 — Reticle of collimator

7.3 Test procedure

Adjust the position of the telescopic sight so that the axes of the two reticles are parallel and the aiming mark corresponds to the centre of the collimator reticle.

When adjusting the line of sight of the test specimen throughout its specified range in vertical direction only, the aiming mark shall not fall outside the specified angular tolerance.

Repeat the above procedure for the horizontal adjustment range.

The uncertainty of measurement of α shall not exceed 0,5°.

7.4 Test report

A test report shall be presented and shall include the general information specified in [Clause 10](#) and the result of the test as specified in [7.3](#).

8 Method of measurement of line of sight shift due to zooming

8.1 Principle

This method is only applicable for test specimens with a reticle in the second image plane.

Due to the tolerances of the mechanical parts of the test specimen, the line of sight may vary while zooming. To determine the deviation in pointing of the line of sight due to zooming, the following test method should be applied.

8.2 Test arrangement

8.2.1 General

Measurement of the line of sight shift due to zooming shall be carried out with the test arrangement shown in [Figure 6](#).

The measuring set-up consists of a light source, an adjustable object-side collimator with a test target, a rigid test specimen mounting, and an auxiliary telescope.

It shall be possible to adjust the alignment of the collimator and the telescopic sight relative to each other. This can be achieved by adjusting the collimator and/or the telescopic sight.

In order to avoid misalignment between the collimator and the telescopic sight when controls on the latter are actuated, it may be advisable to keep the telescopic sight rigidly mounted in a sturdy stationary fixture while making the adjustments necessary to accomplish correct alignment by moving the collimator.

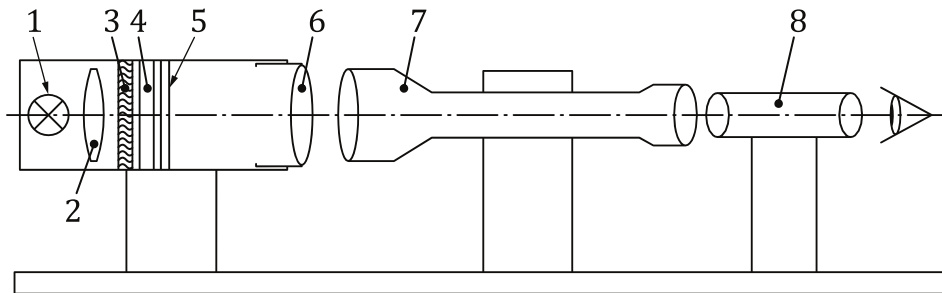

Key

- 1 illumination unit
- 2 condenser
- 3 scattering plate
- 4 filter
- 5 test target
- 6 adjustable collimator lens
- 7 telescopic sight
- 8 auxiliary telescope

NOTE The object-side collimator is described by the keys 1 to 6.

Figure 6 — Test arrangement for line of sight shift due to zooming

The light source consists of an incandescent lamp, a condenser, a light scattering plate and a filter. The light scattering plate should be a diffusing plate. To avoid chromatic aberration, a green filter (approximately 0,55 μm) shall be used.

The adjustable object-side collimator consists of a test target and a collimator lens. When used at its infinity setting, the test target shall be in the focal plane of the collimator lens. To simulate different object distances, the distance between the collimator lens and the test target should be adjustable.

The collimator shall have a useful diameter larger than that of the objective lens of the telescopic sight under test and a focal length of at least ten times the diameter of the collimator lens. The test target should consist of a circle, a vertical and a horizontal line with tick marks according to [Figure 7](#).

The diameter of the circle should be chosen according to the specifications given in ISO 14135-1 and ISO 14135-2.

EXAMPLE 1 The diameter of the circle should subtend an angle of 0,4 mrad (1,4'), which corresponds to a diameter of 4 cm at 100 m. The tick marks should correspond to a distance of 10 cm at 100 m.

EXAMPLE 2 Alternatively, the diameter of the circle should subtend an angle of 2' for test specimens with a click stop distance in units of minutes of arc (MOA). The tick marks should then correspond to an angle of 5'. The tick marks are not important for this measurement method, but can be convenient for related measurements like click stop distances or the like.

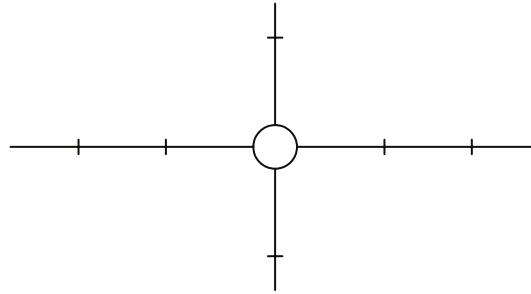

Figure 7 — Test target

8.2.2 Test specimen mounting

The mounting shall be very rigid to ensure a stable pointing during the measurement procedure, especially when turning the zooming facility of the test specimen. The pointing stability of the test specimen's reticle while touching the test specimen shall be sufficient to fulfil the requirements according to ISO 14135-1:2014, Table 2 and ISO 14135-2:2014, Table 2, respectively.

8.2.3 Auxiliary telescope

The auxiliary telescope shall have an aperture larger than the exit pupil of the telescopic sight and a magnifying power sufficient to ensure a precise measurement. It shall be focused to infinity.

8.3 Test procedure

8.3.1 Preparation of the test assembly

The adjustable collimator shall be set to a position equivalent to the parallax-free distance of the test specimen, i.e. at 100 m. This setting gives a virtual image of the test target in the specified distance.

The test specimen shall be set initially to its lowest magnifying power setting. The adjustment range of the reticle position shall be set about its centre position. The eyepiece of the test specimen shall be focused on the reticle of the telescopic sight to obtain a sharp image thereof while viewing through the auxiliary telescope. The test specimen shall be adjusted very carefully to align the centre of its reticle with the image of the centre of the test target's circle.

8.3.2 Determination of the measurement values

With the two centres initially exactly coinciding, the zooming facility of the test specimen shall be turned towards its highest magnifying power. During the zooming movement, a possible position deviation of the two centres shall be watched carefully. The position of the reticle should remain stable. The position of the image of the test target might move in relation to the reticle.

The largest distance between the centres of the test specimen's reticle in any zoom position shall be recorded.

For illustration, see [Figure 8](#). The small grey circles in [Figure 8](#) represent the relative movement between the test specimen's reticle and the image of the test target along the dashed line for various magnifying power settings. The largest difference in this example is about 8 cm (diameter of the surrounding dotted circle). For demonstration purposes, the movement is greatly exaggerated.

When watching the image during zooming, the test target's image is being magnified, while the diameter of the reticle (grey circle) remains stable because of its position in the second image plane of the test specimen.

Instead of showing the magnification and the movement of the test target's image, [Figure 8](#) illustrates the opposite situation as a decreasing and a movement of the reticle (grey circles) to give a clearer drawing.

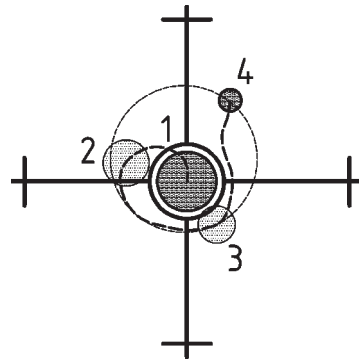

NOTE The numbers 1 to 4 show the order of measurement.

Figure 8 — Example of a movement of the test specimen's reticle relative to the centre of the test target as seen through the auxiliary telescope (normalized representation of the test target)

8.4 Precision of the measurement

The uncertainty of the measurement shall fulfil the requirements according to ISO 14135-1 for general purpose instruments and ISO 14135-2 for high performance instruments.

8.5 Test report

A test report shall be presented and shall include the general information specified in [Clause 10](#) and the result of the test as specified in [8.3](#).

9 Method of measurement of line of sight shift due to focusing

9.1 Principle

This method is only applicable for test specimen with the capability of focusing the object on the reticle. The position of the reticle can be in any focal plane of the telescopic sight (first or/and second plane).

NOTE If the reticle is in the second plane, then for different magnifying powers, the value of line of sight shift due to focusing can be different.

Due to the tolerances of the mechanical and optical parts of the test specimen, the line of sight may vary while focusing. To determine the deviation in pointing of the line of sight due to focusing, the following test method should be applied.

9.2 Test arrangement

9.2.1 General

Measurement of the line of sight shift due to focusing shall be carried out with the test arrangement shown in [Figure 9](#).

The measuring set-up consists of an adjustable object-side collimator with a test target, a rigid test specimen mounting, and an auxiliary telescope.

It shall be possible to adjust the alignment of the collimator and the telescopic sight relative to each other. This can be achieved by adjusting the collimator and/or the telescopic sight.

In order to avoid misalignment between the collimator and the telescopic sight when controls on the latter are actuated, it may be advisable to keep the telescopic sight rigidly mounted in a sturdy stationary fixture while making the adjustments necessary to accomplish correct alignment by moving the collimator.

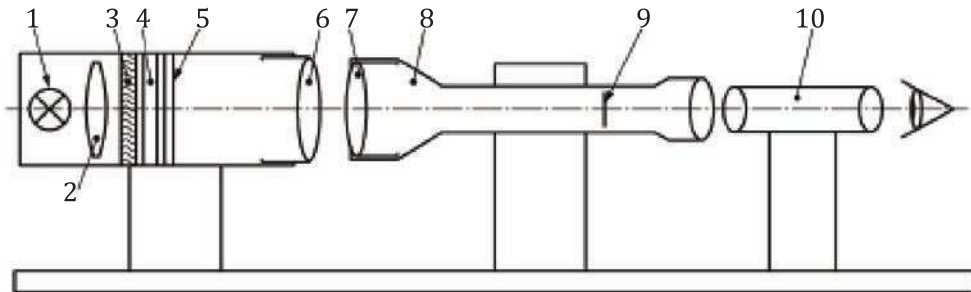

Key

1	illumination unit	6	adjustable collimator lens
2	condenser	7	adjustable objective lens
3	scattering plate	8	telescopic sight
4	filter	9	reticle of telescopic sight
5	test target	10	auxiliary telescope

NOTE The object-side collimator is described by the keys 1 to 6.

Figure 9 — Test arrangement for line of sight shift due to focusing

9.2.2 Collimator

The adjustable object-side collimator consists of a light source, a test target and a collimator lens. When used at its infinity setting, the test target shall be in the focal plane of the collimator lens. To simulate different object distances, the distance between the collimator lens and the test target should be adjustable, in a range at least equal to the focusing system adjustment range of the telescopic sight under test.

The collimator shall have line of sight stability while focusing well above the stability of the test specimen. The collimator shall have a useful diameter larger than that of the objective lens of the telescopic sight under test and it should have a focal length suitable for reticle engraving.

NOTE The recommended focal length is in the order of 1 000 mm.

The light source consists of an incandescent lamp, a condenser, a light scattering plate and a filter. The light scattering plate should be a diffusing plate. To avoid chromatic aberration, a green filter (approximately 0,55 μm) shall be used.

The test target should consist of a number of circles, a vertical and a horizontal line according to [Figure 10](#). The number and the diameter of the circles should be chosen according to the focusing range and performance class of the telescopic sight.

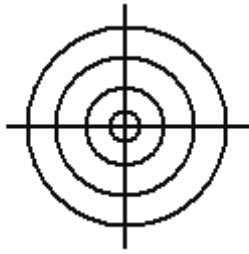

Figure 10 — Test target

9.2.3 Telescopic sight

The mounting shall be very rigid to ensure a stable pointing during the measurement procedure, especially when turning the focusing facility of the test specimen. The pointing of the test specimen's reticle while touching the test specimen shall be stable.

9.2.4 Auxiliary telescope

The auxiliary telescope shall have an aperture not less than 8 mm and a magnifying power sufficient to ensure a precise measurement. It shall be focused to infinity.

9.3 Test procedure

9.3.1 Preparation of the test assembly

The adjustable collimator shall always be set to a position equivalent to the parallax-free distance in the adjustment range of the telescopic sight under test. This setting gives a virtual image of the test target in the specified distance.

The focusing facility of the test specimen shall be set initially at the largest distance to the object plane, usually set to infinity. The reticle shall be set to the centre position of its adjustment range to avoid systematic errors due to an off-axis measurement. The correct position can be proved by rotating the sight by 360°. The eyepiece of the test specimen shall be focused on the reticle of the telescopic sight to obtain a sharp image thereof while viewing through the auxiliary telescope. The test specimen shall be adjusted very carefully to align the centre of its reticle with the image of the centre of the test target's circles.

9.3.2 Determination of the measurement values

Then, the adjustable collimator shall be set to a position equivalent to the closest parallax-free distance of the adjustment range of the telescopic sight.

With the two centres initially exactly coinciding, the focusing facility of the test specimen shall be turned towards its closest parallax-free distance. During the focusing movement, the position of the reticle should remain stable. The position of the image of the test target might move in relation to the reticle. The rotation direction of the focusing facility should not be reversed during the measurement.

The angular difference between the two centres shall be recorded at the closest distance.

9.4 Precision of the measurement

The uncertainty of the measurement shall fulfil the specifications.

9.5 Test report

A test report shall be presented and shall include the general information specified in [Clause 10](#) and the result of the test as specified in [9.3](#).

10 General test report

In addition to the presentation of the test results for each test method, the following information, if applicable, shall be provided in each test report:

- a) name of test laboratory;
- b) name of examiner;
- c) date of test;
- d) identification of the test specimen;
- e) details about the test arrangement and/or procedure, if required, and/or if different from those specified in the relevant test method of the ISO 14490 series;
- f) reference to this part of ISO 14490, i.e. ISO 14490-3, as well as to any other part of ISO 14490 used for testing telescopic systems.

If the test report is intended to give the result of more than one test in accordance with ISO 14490 (all parts), the general information specified in a) to f) above will usually only be given once for all tests.

