

---

---

**Earth-moving machinery — Loaders and  
backhoe loaders —**

Part 1:  
**Calculation of rated operating capacity  
and test method for verifying calculated  
tipping load**

*Engins de terrassement — Chargeuses et chargeuses-pelleteuses —  
Partie 1: Calcul de la charge utile nominale et méthode d'essai pour  
vérifier la charge de basculement calculée*



**PDF disclaimer**

This PDF file may contain embedded typefaces. In accordance with Adobe's licensing policy, this file may be printed or viewed but shall not be edited unless the typefaces which are embedded are licensed to and installed on the computer performing the editing. In downloading this file, parties accept therein the responsibility of not infringing Adobe's licensing policy. The ISO Central Secretariat accepts no liability in this area.

Adobe is a trademark of Adobe Systems Incorporated.

Details of the software products used to create this PDF file can be found in the General Info relative to the file; the PDF-creation parameters were optimized for printing. Every care has been taken to ensure that the file is suitable for use by ISO member bodies. In the unlikely event that a problem relating to it is found, please inform the Central Secretariat at the address given below.



**COPYRIGHT PROTECTED DOCUMENT**

© ISO 2007

All rights reserved. Unless otherwise specified, no part of this publication may be reproduced or utilized in any form or by any means, electronic or mechanical, including photocopying and microfilm, without permission in writing from either ISO at the address below or ISO's member body in the country of the requester.

ISO copyright office  
Case postale 56 • CH-1211 Geneva 20  
Tel. + 41 22 749 01 11  
Fax + 41 22 749 09 47  
E-mail [copyright@iso.org](mailto:copyright@iso.org)  
Web [www.iso.org](http://www.iso.org)

Published in Switzerland

# Contents

Page

Foreword.....	iv
<b>1</b> <b>Scope</b> .....	<b>1</b>
<b>2</b> <b>Normative references</b> .....	<b>1</b>
<b>3</b> <b>Terms and definitions</b> .....	<b>2</b>
<b>4</b> <b>Symbols and abbreviated terms</b> .....	<b>3</b>
<b>5</b> <b>Requirements</b> .....	<b>4</b>
<b>5.1</b> <b>Calculation of rated operating capacity</b> .....	<b>4</b>
<b>5.2</b> <b>Loader configurations</b> .....	<b>5</b>
<b>5.3</b> <b>Procedure for calculating tipping load at maximum reach</b> .....	<b>6</b>
<b>6</b> <b>Tipping load verification test</b> .....	<b>7</b>
<b>6.1</b> <b>General</b> .....	<b>7</b>
<b>6.2</b> <b>Test equipment</b> .....	<b>8</b>
<b>6.3</b> <b>Test measurement of minimum tipping load</b> .....	<b>8</b>
<b>6.4</b> <b>Verification</b> .....	<b>8</b>
<b>6.5</b> <b>Test report</b> .....	<b>8</b>
<b>Annex A</b> (informative) <b>Heavy single object (HSO)</b> .....	<b>15</b>
<b>Bibliography</b> .....	<b>17</b>

## Foreword

ISO (the International Organization for Standardization) is a worldwide federation of national standards bodies (ISO member bodies). The work of preparing International Standards is normally carried out through ISO technical committees. Each member body interested in a subject for which a technical committee has been established has the right to be represented on that committee. International organizations, governmental and non-governmental, in liaison with ISO, also take part in the work. ISO collaborates closely with the International Electrotechnical Commission (IEC) on all matters of electrotechnical standardization.

International Standards are drafted in accordance with the rules given in the ISO/IEC Directives, Part 2.

The main task of technical committees is to prepare International Standards. Draft International Standards adopted by the technical committees are circulated to the member bodies for voting. Publication as an International Standard requires approval by at least 75 % of the member bodies casting a vote.

Attention is drawn to the possibility that some of the elements of this document may be the subject of patent rights. ISO shall not be held responsible for identifying any or all such patent rights.

ISO 14397-1 was prepared by Technical Committee ISO/TC 127, *Earth-moving machinery*, Subcommittee SC 1, *Test methods relating to machine performance*.

This second edition cancels and replaces the first edition (ISO 14397-1:2002), which has been technically revised.

ISO 14397 consists of the following parts, under the general title *Earth-moving machinery — Loaders and backhoe loaders*:

- *Part 1: Calculation of rated operating capacity and test method for verifying calculated tipping load*
- *Part 2: Test method for measuring breakout forces and lift capacity to maximum lift height*

# Earth-moving machinery — Loaders and backhoe loaders —

## Part 1: Calculation of rated operating capacity and test method for verifying calculated tipping load

### 1 Scope

This part of ISO 14397 specifies the means for determining the rated operating capacity of wheeled or crawler loaders or of the loader portion of backhoe loaders, having buckets and material handling forks, as defined in ISO 6165. It gives standard methods for the calculation and test verification of the tipping load (mass).

It is applicable only to the use of buckets and forks on loaders.

**NOTE** Certain attachments can exceed the normal operating capacity and will require restricted machine operating conditions, such as reduced machine speed or limited lifting height. Refer to the attachment manufacturer's instructions for the intended use of the attachment.

### 2 Normative references

The following referenced documents are indispensable for the application of this document. For dated references, only the edition cited applies. For undated references, the latest edition of the referenced document (including any amendments) applies.

ISO 6016:1998, *Earth-moving machinery — Methods of measuring the masses of whole machines, their equipment and components*

ISO 6165:2006, *Earth-moving machinery — Basic types — Identification and terms and definitions*

ISO 6746-1:2003, *Earth-moving machinery — Definitions of dimensions and codes — Part 1: Base machine*

ISO 7546:1983, *Earth-moving machinery — Loader and front loading excavator buckets — Volumetric ratings*

ISO 9248:1992, *Earth-moving machinery — Units for dimensions, performance and capacities, and their measurement accuracies*

ISO 14397-2, *Earth-moving machinery — Loaders and backhoe loaders — Part 2: Test method for measuring breakout forces and lift capacity to maximum lift height*

### 3 Terms and definitions

For the purposes of this document, the terms and definitions given in ISO 6165 and ISO 6746-1, and the following, apply.

#### 3.1 rated operating capacity

$N$   
calculated value, in kilograms, representing normal loading under typical operating conditions

#### 3.2 tipping load at maximum reach

$m_{\text{tip}}$   
minimum mass, in kilograms, that, when placed in the loader bucket or on forks at maximum moment arm position, will cause the loader to achieve the tipping limit condition in its least stable configuration, with the loader placed on a hard, level surface and the resultant force acting vertically through the centroid of the rated bucket volume as specified in ISO 7546 or the fork load centre as specified in 5.2.6 and shown in Figure 1

#### 3.3 lift capacity to maximum height

$m_{\text{lift}}$   
mass, in kilograms, which can be lifted from the ground to maximum height using the lift cylinder or cylinders at hydraulic circuit working pressure, with the bucket positioned to hold the maximum load or the forks positioned horizontally, and with the resultant force acting vertically through the centroid of the rated bucket volume as specified in ISO 7546 or the fork load centre as specified in 5.2.6 and shown in Figure 1

NOTE See also ISO 14397-2.

#### 3.4 maximum moment arm

$n$   
maximum horizontal distance from the load centre of gravity to the tipping line when the bucket is positioned to hold the maximum load or the forks are positioned horizontally

See Figures 2 to 8.

#### 3.5 tipping limit condition

(wheeled loaders) condition in which at least one of the wheels farthest from the tipping line no longer touches the ground

#### 3.6 tipping limit condition

(crawlers with rigid frame suspension) condition when the front track rollers no longer touch the track

NOTE For other types of suspension, the tipping limit condition is as specified by the manufacturer.

#### 3.7 tipping line

line about which the loader tips

See Figures 2 to 8.

#### 3.8 operating mass

mass of the base machine with equipment and empty attachment as specified by the manufacturer, and with the operator (75 kg), full fuel tank and all fluid systems at the levels specified by the manufacturer

**3.9****hydraulic circuit working pressure**

pressure applied to the specific hydraulic lifting circuit by the hydraulic pump or pumps

**3.10****swing loader**

loader having a swing type lift arm which can rotate to the left and right of the straight position

**3.11****stability factors**

$k$

factors accounting for the effects of the operating surface and of the dynamic forces caused by travel speed, tyre deflection, etc., used in rated operating capacity calculation

**4 Symbols and abbreviated terms**

$A1$	articulation angle, as defined in ISO 6746-1	°
$D$	load centre of gravity distance	m
$G_1$	measured load on the front wheel at the opposite side of the tipping line (without load in bucket)	kg
$G_2$	measured load on the rear wheel at the opposite side of the tipping line (without load in bucket)	kg
$G_H$	measured load on the rear axle (without load in bucket)	kg
$k$	stability factors (see Table 1)	—
$L2$	crawler base, as defined in ISO 6746-1	m
$L3$	wheel base, as defined in ISO 6746-1	m
$L5$	rear axle to hinge (pivot of the articulated steering), as defined in ISO 6746-1	m
$m_{\text{lift}}$	lift capacity to maximum height	kg
$m_{\text{tip}}$	tipping load at maximum reach	kg
$N$	rated operating capacity	kg
$n$	maximum moment arm	m
$n_1$	moment arm of load $G_1$ (horizontal distance between centre of action of $G_1$ and side tipping line)	m
$n_2$	moment arm of load $G_2$ (horizontal distance between centre of action of $G_2$ and side tipping line)	m
$W1$	maximum width, as defined in ISO 6746-1 (see also ISO 14397-2)	m
$W2$	track gauge, as defined in ISO 6746-1 (see also ISO 14397-2)	m
$W3$	tread (wheel type), as defined in ISO 6746-1	m
$W4$	track shoe width, as defined in ISO 6746-1 (see also ISO 14397-2)	m

## 5 Requirements

### 5.1 Calculation of rated operating capacity

For each type of loader, the configurations in which the loader is most likely to tip over are assessed and the corresponding tipping line is determined. The rated operating capacity,  $N$ , is then given by Equation (1):

$$N = k \times m_{\text{tip}}$$

or

$$N = m_{\text{lift}} \tag{1}$$

(whichever gives the lesser result)

where

$k$  is the stability factor determined from Table 1, based on the configuration;

$m_{\text{tip}}$  is the tipping load at maximum reach, determined in accordance with Clause 6 or calculated using Equation (2):

$$m_{\text{tip}} = \sum_i \frac{G_i \times n_i}{n} \tag{2}$$

where

$G_i$  is a partial load that opposes the tipping over of the loader;

$n$  is the maximum moment arm length;

$n_i$  is its corresponding moment arm with respect to the tipping line;

$m_{\text{lift}}$  is the lift capacity to maximum height, determined in accordance with ISO 14397-2.

NOTE See 5.3 for the actual formula for calculating  $N$  for specific loader types.

**Table 1 — Determination of stability factor**

Loader configuration	$k$
Wheeled machines with bucket or forks	0,50
Crawler machines with bucket or forks	0,35
<p>NOTE 1 The stability factor, <math>k</math>, is for normal operation. For wheeled machines, normal operation includes operating on a hard, substantially smooth and level surface with a maximum travel speed of 15 km/h. For crawler machines normal operation includes softer ground and not as smooth or level surfaces as wheeled machine conditions, with a maximum travel speed of 6 km/h.</p> <p>NOTE 2 Derivative use of wheel or crawler loaders requires a risk assessment to determine the <math>k</math> factor that will assure stable operation. See example in Annex A.</p>	



## 5.2 Loader configurations

### 5.2.1 General

The loader shall be the standard version specified by the manufacturer.

If the tipping load is determined under specific conditions — as is the case with additional counterweights, ripper, backhoe or tyre ballast — then these conditions shall be specified in the operator's manual and advertising literature so that the stable operating conditions are clearly defined.

The backhoe portion of backhoe loaders shall be in the transport position, as specified by the manufacturer.

The tipping loads used in manuals or advertising shall specify the operating conditions and configurations including tyre inflation upon which the tipping load (mass) ratings are based.

### 5.2.2 Rigid-frame type

Rigid-frame wheeled loaders and backhoe loaders with steered wheels shall be in the straight-ahead position (see Figures 2 and 4).

### 5.2.3 Articulated-frame type

Articulated-frame wheeled loaders and backhoe loaders shall be positioned with the frames both straight and fully articulated to the right and left (see Figure 3).

### 5.2.4 Swing-arm type

Swing-arm type wheeled loaders shall be turned in the most unstable position, as specified by the manufacturer (see Figures 5 and 6).

### 5.2.5 Bucket applications

The bucket shall be positioned to provide the maximum moment arm, as shown in Figures 2 to 7.

### 5.2.6 Fork applications

The forks shall be horizontal and positioned to provide maximum moment arm at the load centre, with top-clamp closed when so equipped.

The load centre of gravity distance,  $D$ , is determined as a point on the longitudinal centreline of the machine at half the distance from the most rearward point of the load opening to the tip of the fork (see Figure 1).

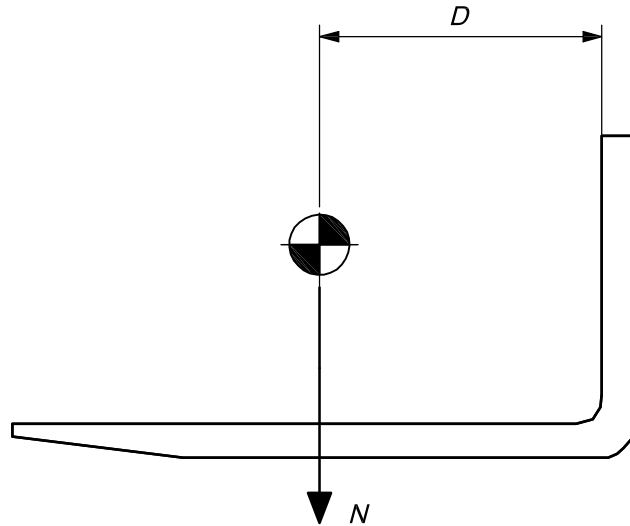

Figure 1 — Load centre distance with fork arms

### 5.3 Procedure for calculating tipping load at maximum reach

#### 5.3.1 Wheeled loaders and backhoe loaders — Articulated or Ackermann steering

##### 5.3.1.1 General

Measure the load,  $G_H$ , in kilograms, on the rear axle, with the empty bucket positioned as shown in Figure 2, 3 or 4, or the forks positioned according to 5.2.6, and with full articulation in the case of articulated machines.

For compact loaders, the calculation method given for articulated or straight-frame machines may only be used if

$$A1 \leq 45^\circ \text{ and } \frac{W3}{L3} \leq 0,7 \quad (3)$$

##### 5.3.1.2 Wheeled loaders and backhoe loaders — Articulated steering at maximum articulation

With the steering system at maximum articulation, right and left, calculate the rated operating capacity, in kilograms, using Equation (4):

$$N = k \times m_{\text{tip}} = k \times \frac{G_H (L3 - L5 + L5 \times \cos A1)}{n} \quad (4)$$

##### 5.3.1.3 Straight-frame wheeled loaders and backhoe loaders — Ackermann steering

With the steering system in the straight-ahead position, calculate the rated operating capacity, in kilograms, using Equation (5):

$$N = k \times m_{\text{tip}} = k \times \frac{G_H \times L3}{n} \quad (5)$$

#### 5.3.2 Swing-arm type wheeled loaders — Articulated or Ackermann steering

##### 5.3.2.1 Swing-arm type wheeled loaders — Swing arm in straight position — Articulated steering

Use Equation (4). See Figures 5 and 6.

### 5.3.2.2 Swing-arm type wheeled loaders — Swing arm in straight position — Ackermann steering

Use Equation (5).

### 5.3.2.3 Swing-arm type wheeled loaders — Swing arm perpendicular to tipping line — Articulated steering at maximum articulation and to most critical side

Measure loads,  $G_1$  and  $G_2$ , in kilograms, on the two wheels (front and rear) opposite the bucket or fork position, with the empty bucket or forks and the swing arm perpendicular to the tipping line, at maximum steering articulation and to the most critical side, as defined by the manufacturer.

Calculate the rated operating capacity,  $N$ , in kilograms, using Equation (6):

$$N = k \times m_{\text{tip}} = k \times \frac{G_1 n_1 + G_2 n_2}{n} \quad (6)$$

where

$$n_1 = W3 \times \cos \left[ \arccot \left( \frac{L3 - L5 + L5 \times \cos A1 - 0,5 \times W3 \times \sin A1}{L5 \times \sin A1 + 0,5 \times W3 \times \cos A1 - 0,5 \times W3} \right) \right] \quad \text{in metres} \quad (7)$$

$$n_2 = W3 \times \cos \left[ A1 - \arccot \left( \frac{L3 - L5 + L5 \times \cos A1 - 0,5 \times W3 \times \sin A1}{L5 \times \sin A1 + 0,5 \times W3 \times \cos A1 - 0,5 \times W3} \right) \right] \quad \text{in metres} \quad (8)$$

See Figure 7.

### 5.3.2.4 Swing-arm type wheeled loaders — Swing arm perpendicular to tipping line — Ackermann steering at maximum steering angle

Measure loads,  $G_1$  and  $G_2$ , in kilograms, on the two wheels (front and rear) opposite the bucket or fork position, with the bucket or forks empty, the swing arm perpendicular to the tipping line, and at the maximum steering angle.

Calculate the rated operating capacity,  $N$ , in kilograms, using Equation (9):

$$N = k \times \frac{(G_1 + G_2) \times W3}{n} \quad (9)$$

### 5.3.3 Crawler loader

Measure load,  $G_H$ , on the sprocket centreline, with the empty bucket positioned as shown in Figure 8 or the forks positioned according to 5.2.6.

Calculate the rated operating capacity,  $N$ , in kilograms, using Equation (10):

$$N = k \times \frac{G_H \times L2}{n} \quad (10)$$

## 6 Tipping load verification test

### 6.1 General

A variability exists between the calculated values and the test values. This is because dynamic forces acting on wheeled loaders and backhoe loaders (caused by travel speed, tyre deflection, the suspension system and tyre penetration of the operating surface under test conditions) will result in values lower than those

determined by calculation. The loader test results may be influenced by dynamic factors associated with ground contact and tyre and suspension design.

## **6.2 Test equipment**

Test equipment shall be in accordance with ISO 14397-2.

The machine shall be configured in accordance with 5.2.

## **6.3 Test measurement of minimum tipping load**

Using a hydraulic cylinder or mechanical winch, apply a vertical downward force acting through the bucket volume centroid or forks load centre to find the tipping condition.

For a wheeled loader, wheeled backhoe loader or wheeled swing loader, record the force when the rear tyre or tyres leave the ground in the straight-ahead position and convert the force to the equivalent tipping load (mass), in kilograms. In the case of an articulated configuration, test with the oscillating axle unblocked and take the force measurement when one wheel opposite the tipping line leaves the ground.

For a crawler loader, take the force measurement when the front rollers leave the track link surface. The oscillating axle shall be unlocked, except in the case of swing loaders, where an automatic activation of the oscillating axle occurs during lift arm swinging.

## **6.4 Verification**

The calculated values shall be within 2 % of the test results, in accordance with ISO 9248.

## **6.5 Test report**

The following information shall be included in the test report, upon verification of the calculated tipping load:

- a) manufacturer;
- b) model;
- c) type;
- d) test machine product identification number;
- e) machine operating mass for test (see ISO 6016), in kilograms;
- f) mass and location of additional counterweights, in kilograms ;
- g) steering, comprising
  - maximum articulated steering angle for articulated-frame loaders, in degrees, and
  - maximum swing angle of swing loader arms, in degrees;
- h) tyre type and size(s);
- i) tyre pressure(s), in kilopascals;
- j) type and width of track shoes, crawler loaders (see ISO 6746-1);
- k) lift capacity to maximum height, in kilograms;

- l) rear axle load for wheeled loaders and backhoe loaders in accordance with 5.3.1.1, in kilograms;
- m) side loads for swing loaders in accordance with 5.3.2.3, in kilograms;
- n) tipping load at maximum reach, in kilograms;
- o) rated operating capacity in accordance with 5.3, in kilograms;
- p) rated operating capacity for swing loaders, in accordance with 5.3.2.3 and 5.3.2.4, specifying
  - front, in kilograms, and
  - swing angle, in degrees.

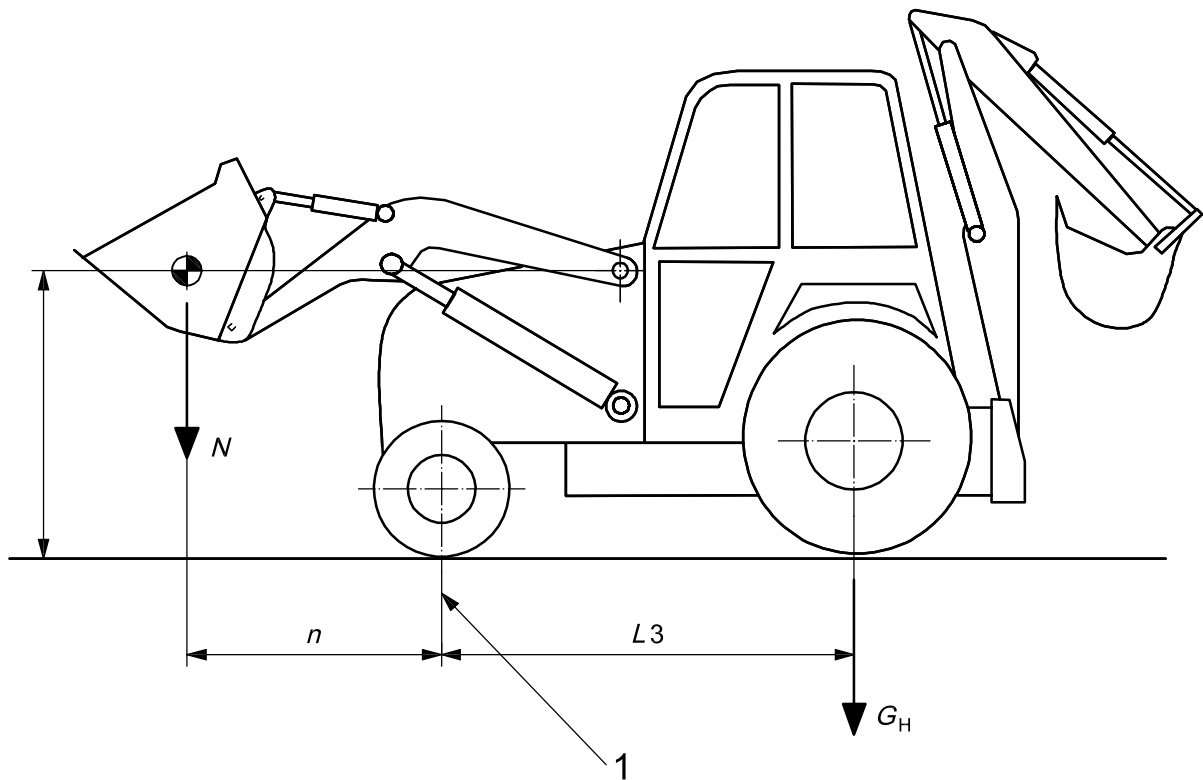

**Key**

- 1 tipping line

**Figure 2 — Backhoe loader**

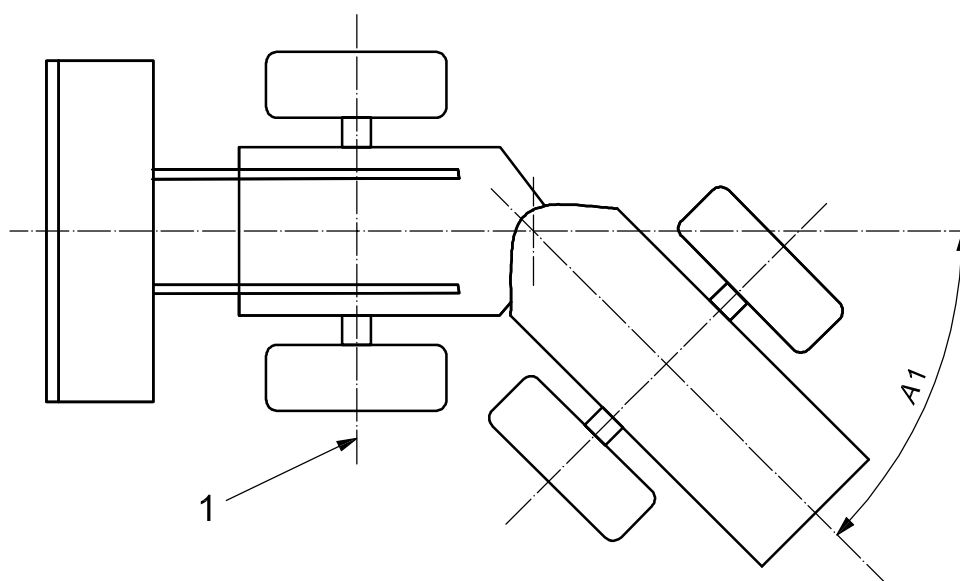
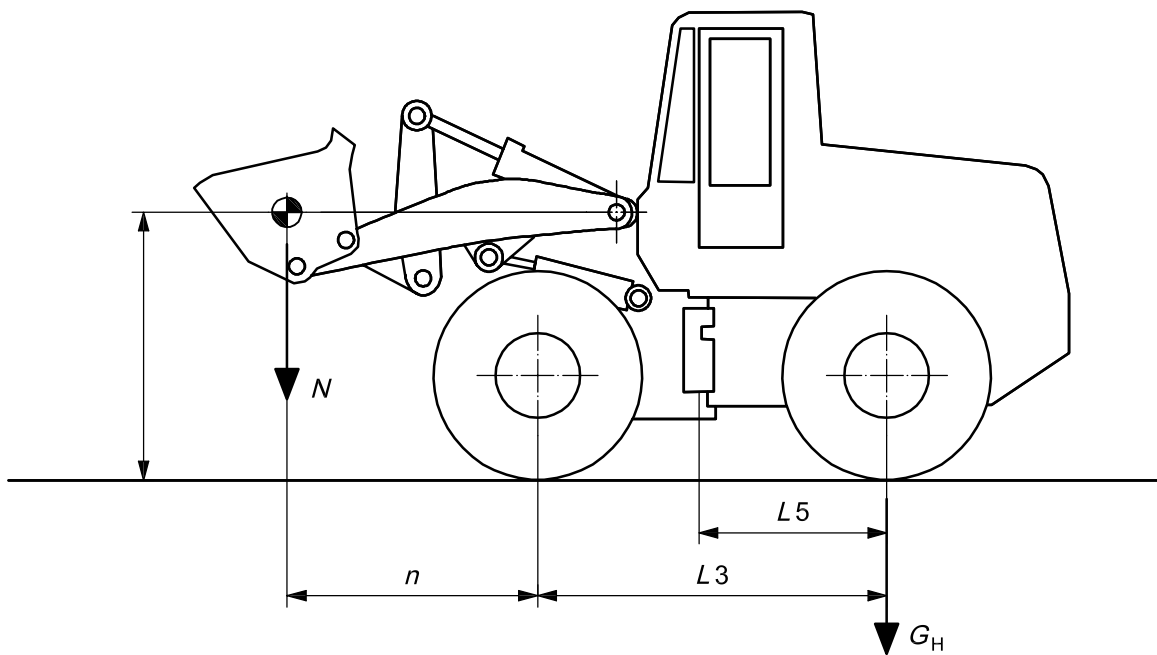

**Key**

- 1 tipping line

**Figure 3 — Articulated-frame wheeled loader**

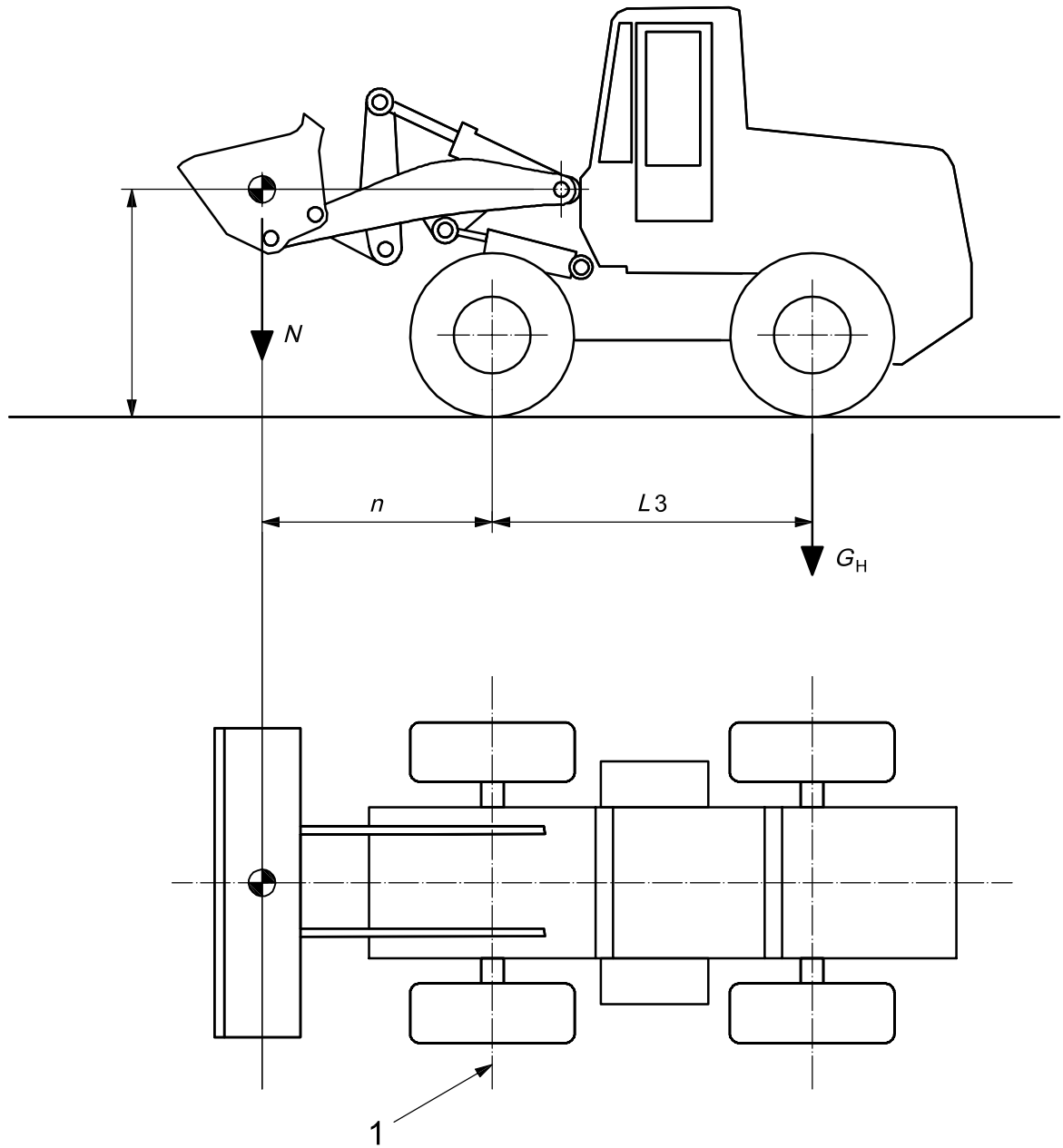

**Key**

1 tipping line

**Figure 4 — Straight-frame wheeled loader**

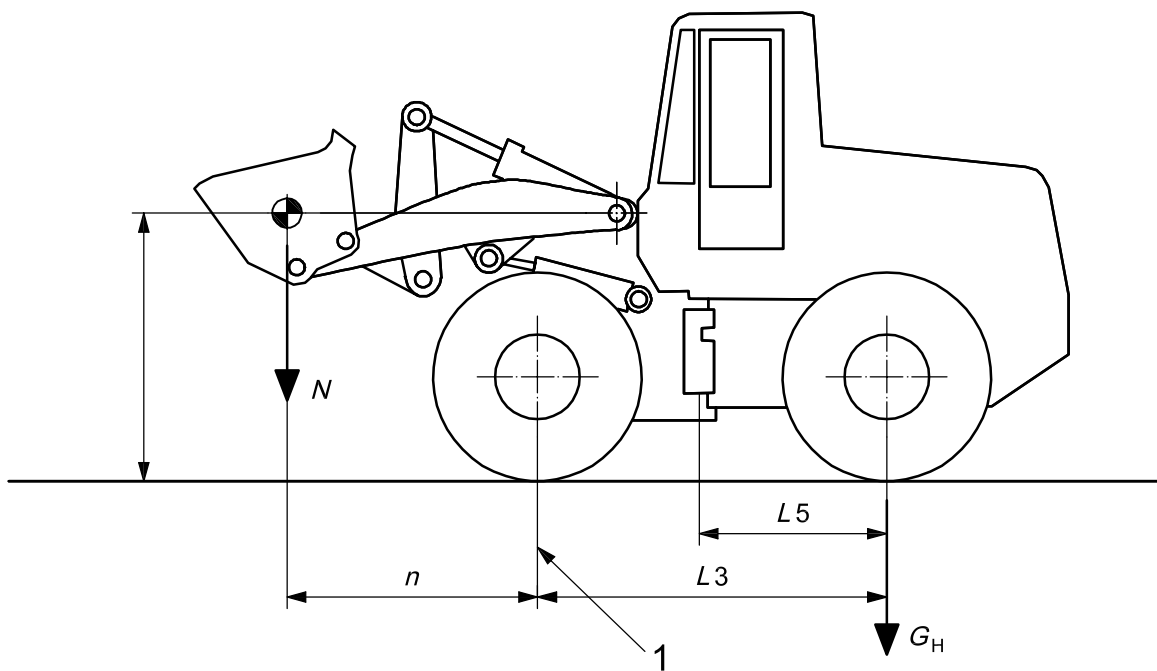

**Key**

1 tipping line

**Figure 5 — Swing-arm type wheeled loader in straight position**

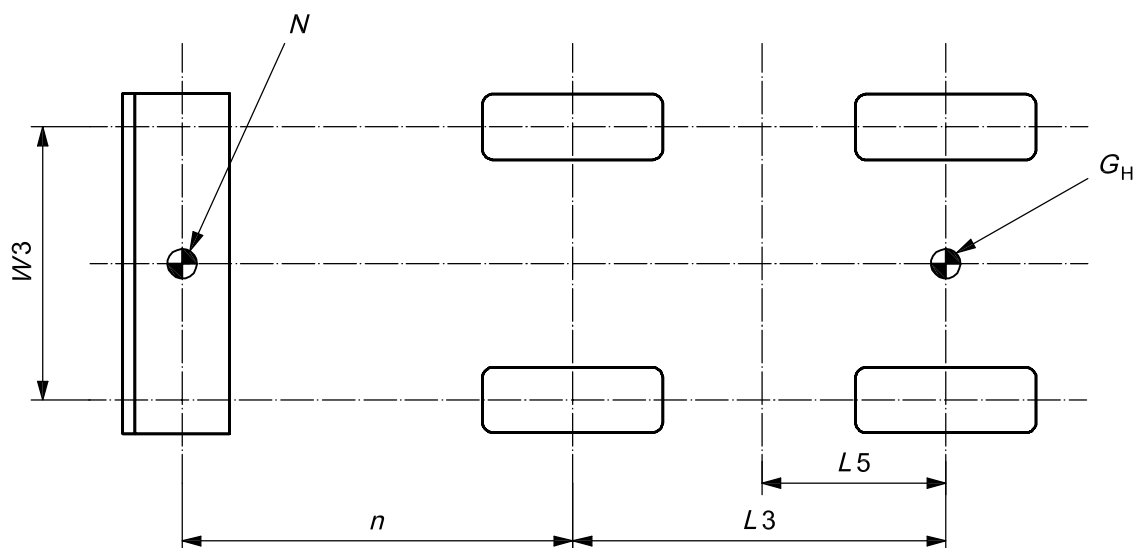

**Figure 6 — Swing-arm type wheeled loader in straight position**



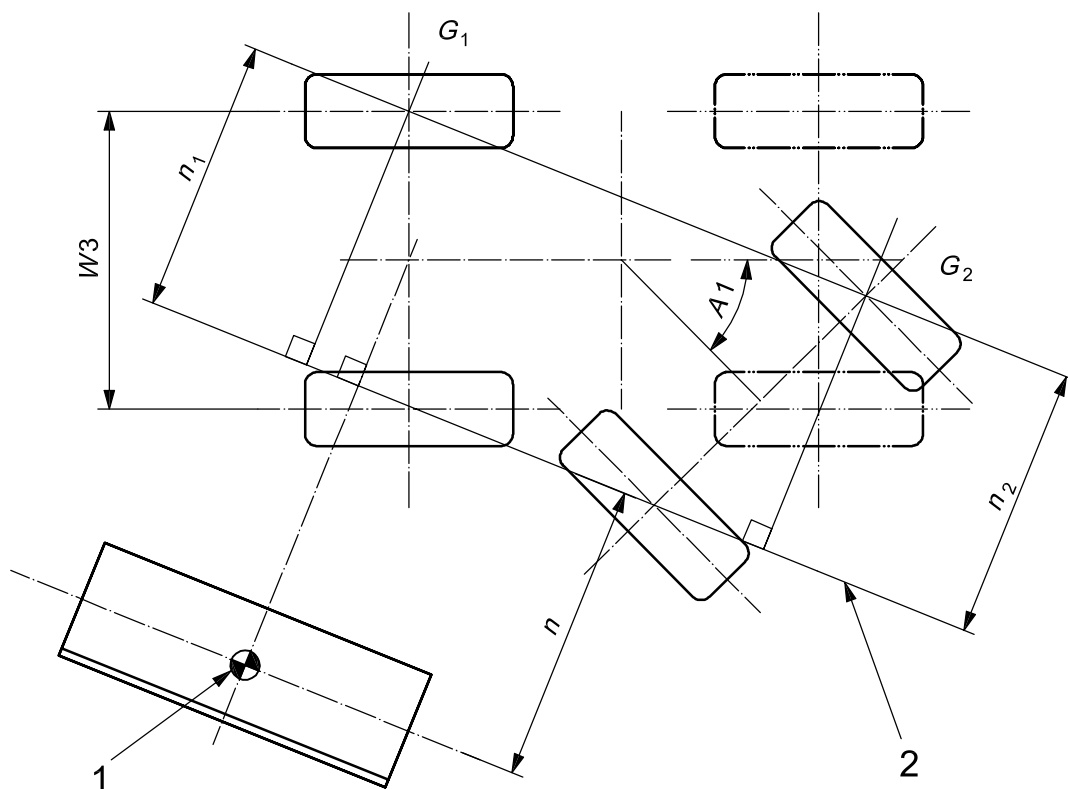

**Key**

- 1 bucket centroid
- 2 side tipping line

**Figure 7 — Swing-arm type wheeled loader with articulated frame at full articulation and lift arm perpendicular to tipping line**

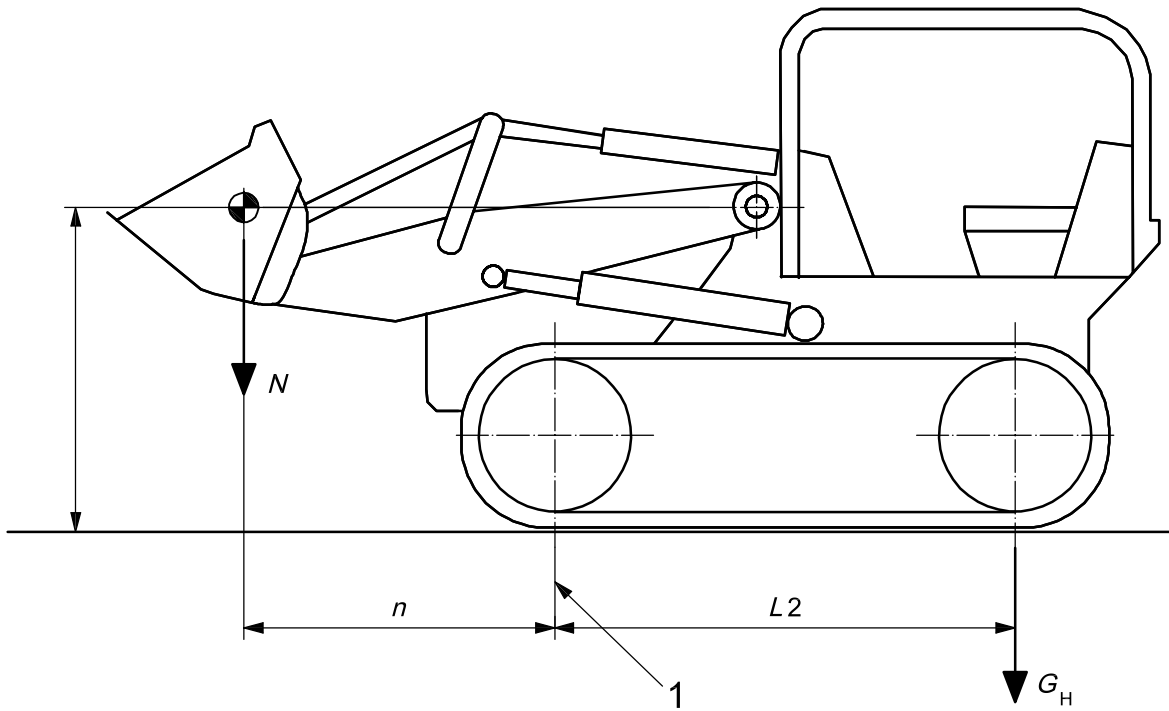

**Key**

1 tipping line

**Figure 8 — Crawler loader**

## Annex A (informative)

### Heavy single object (HSO)

Derivative uses of wheeled and crawler loaders exist that include specialized machines used in restricted applications that could permit less restrictive, or require more restrictive, stability factors. This annex gives an example of such an application.

#### A.1 Handling an HSO

The rated operating conditions of wheeled loaders in HSO applications (usually large, single blocks or objects) are based on the following criteria:

- travel/transporting speed of less than 2 km/h;
- firm and level ground;
- maintaining lift capacity during travel close to the ground;
- use of actual HSO attachment.

##### A.1.1 Rated operating capacity — Loading and working (transport) modes

The tipping limit condition shall be determined according to this part of ISO 14397, but with the actual HSO handling attachment installed.

If the machine frame is articulated, the following criteria shall be fulfilled:

- machine speed of less than 2 km/h;
- machine must be in a straight-ahead position when loading the transport carrier;
- the load in a fully rolled back position;
- the load is lifted to maximum moment arm.

The rated operating capacity according to this mode, as a percentage of tipping limit condition, shall not exceed the applicable value specified in Table A.1.

The machine is articulated during transport, but with the load carried as low as possible.

**Table A.1 — Stability factor,  $k$ , — Loading and transport modes**

Ground condition	Wheeled loaders	Crawler loaders
Firm and level ground	0,8	0,6

It shall be possible to control and move the load in all positions foreseen by the manufacturer by considering all the relevant hydraulic circuit's working pressure involved.

**A.1.2 Calculation of rated operating capacity**

For each type of loader, the configurations in which the loader is most likely to tip over are assessed and the corresponding tipping line is determined. The rated operating capacity,  $N$ , is then given by Equation (1):

$$N = k \times m_{tip}$$

or

$$N = m_{lift}$$

(whichever gives the lesser result)

**A.1.3 HSO handling attachment and load centre of gravity**

In order to indicate rated operating capacity in commercial documents, to provide comparable specifications and to support assessment of a suitable HSO handling equipment and attachment, a transversal square cross-section of the load should be considered. The estimated location of the centre of gravity distance on the attachment (see Figure A.1) should therefore be standardized and selected in accordance with Table A.2.

**Table A.2 — Rated operating capacity for HSO load — Load centre of gravity coordinates  $X$  and  $Y$**

Load kg	Position of load centre of gravity	
	$X$ mm	$Y$ mm
< 10 000	600	500
> 10 000	900	800

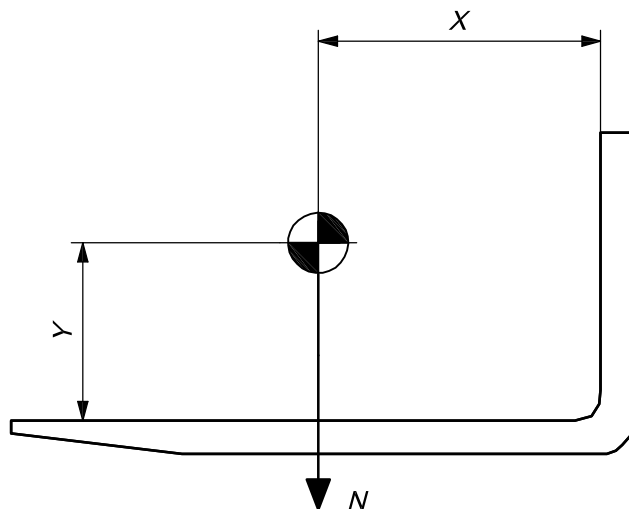

**Key**

- $X$  horizontal distance
- $Y$  vertical distance

**Figure A.1 — Stone fork (example) — Test load application position**

## Bibliography

- [1] ISO 7131:1997, *Earth-moving machinery — Loaders — Terminology and commercial specifications*

This page is intentionally blank.

This page is intentionally blank.

