

INTERNATIONAL
STANDARD

ISO
14359

First edition
1997-03-01

**Winter-sports equipment — Marking of
parts made of polymer materials**

*Matériel de sports d'hiver — Marquage des éléments fabriqués en
matériaux polymères*



Reference number
ISO 14359:1997(E)

Foreword

ISO (the International Organization for Standardization) is a worldwide federation of national standards bodies (ISO member bodies). The work of preparing International Standards is normally carried out through ISO technical committees. Each member body interested in a subject for which a technical committee has been established has the right to be represented on that committee. International organizations, governmental and non-governmental, in liaison with ISO, also take part in the work. ISO collaborates closely with the International Electrotechnical Commission (IEC) on all matters of electrotechnical standardization.

Draft International Standards adopted by the technical committees are circulated to the member bodies for voting. Publication as an International Standard requires approval by at least 75 % of the member bodies casting a vote.

International Standard ISO 14359 was prepared by Technical Committee ISO/TC 83, *Sports and recreational equipment*, Subcommittee SC 3, *Ski bindings*.

Annex A of this International Standard is for information only.

© ISO 1997

All rights reserved. Unless otherwise specified, no part of this publication may be reproduced or utilized in any form or by any means, electronic or mechanical, including photocopying and microfilm, without permission in writing from the publisher.

International Organization for Standardization

Case postale 56 • CH-1211 Genève 20 • Switzerland

Internet central@iso.ch

X.400 c=ch; a=400net; p=iso; o=isocs; s=central

Printed in Switzerland

Winter-sports equipment – Marking of parts made of polymer materials

1 Scope

This International Standard specifies the marking of all separable parts made of polymer materials (plastics), which are used in winter-sports equipment (e.g. ski boots, ski-bindings). It is not applicable to compound materials with duroplastic components (e.g. skis).

This International Standard specifies the minimum requirements for identifying materials. This is to enable a complete separation of polymer materials for recycling.

2 Normative references

The following standards contain provisions which, through reference in this text, constitute provisions of this International Standard. At the time of publication, the editions indicated were valid. All standards are subject to revision, and parties to agreements based on this International Standard are encouraged to investigate the possibility of applying the most recent editions of the standards indicated below. Members of IEC and ISO maintain registers of currently valid International Standards.

ISO 1043-1:1997, *Plastics — Symbols and abbreviated terms — Part 1: Basic polymers and their special characteristics*.

ISO 1043-2:1988, *Plastics — Symbols — Part 2: Fillers and reinforcing materials*.

ISO 1629:1995, *Rubber and latices — Nomenclature*.

3 Marking of parts

All parts made of polymer materials shall be marked in accordance with this International Standard to enable separation for recycling, unless incontrovertible technical or geometrical reasons preclude their marking.

4 Marking system

4.1 Thermoplastics and thermosetting plastics

4.1.1 Marking shall consist of the internationally agreed symbols in accordance with ISO 1043-1 and ISO 1043-2. If in doubt, the symbols listed in annex A may be used.

Marking shall be structured as follows.

- | | |
|--|-------------|
| a) Symbols for basic polymer materials: | see table 1 |
| b) Material variant: | see table 1 |
| c) Filler and reinforcing materials: | see table 2 |
| d) Proportionate filler content as a percentage by mass. | |

EXAMPLE

> PA66-GF30 <

a) b) c) d)

The symbols for thermoplastics and thermosetting plastics used most frequently in the winter-sports industry are listed in table 1. Table 2 gives symbols for filler and reinforcing materials.

4.1.2 In the case of multiphase materials, the main components shall be marked; blends are separated by a plus sign, copolymers by a diagonal line.

EXAMPLES

For blends:

>PC+PBT<

For copolymers:

>PA6/12<

4.1.3 In the case of compound elements, i.e. inherent compound materials, the material symbols shall be preceded by the designation of the individual parts.

EXAMPLE

Housing >POM<

Window >PC<

4.1.4 If a filler material or reinforcing material is used, this shall be written after the material variant, separated by a hyphen (see 4.1.1).

If a mixture of several filler or reinforcing materials is used, these should be added in brackets, separated by a plus sign.

EXAMPLE

>PA66-(GF25+MD15)<

4.1.5 If parts are made of different materials in the same mould, it is possible to indicate the material used by using a rotatable arrow (see figure 1).

Dimensions in millimetres

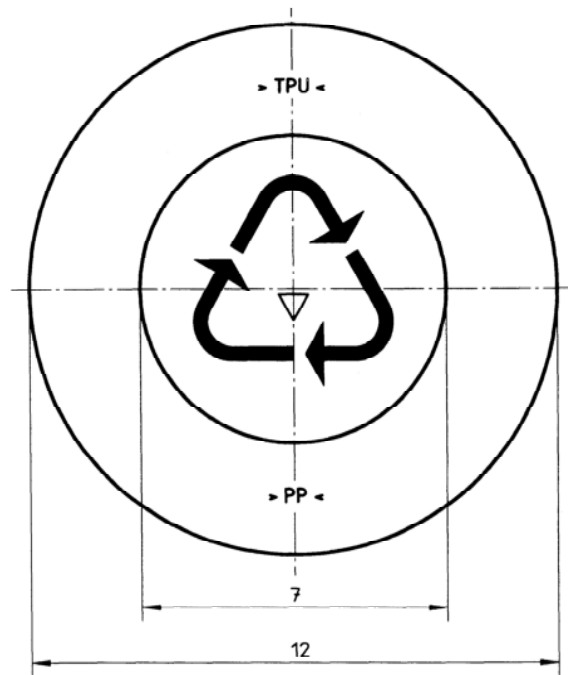

Figure 1 — Example of a rotatable arrow symbol

4.2 Elastomers (see table 3)

4.2.1 Marking shall be based on the symbols internationally agreed upon in accordance with ISO 1629.

EXAMPLE

>EPDM<

4.2.2 In the case of vulcanized materials based on rubber blends, the main components shall be given in the order of highest content.

EXAMPLE

>Cr+NBR<

4.2.3 In the case of compound parts, i.e. inherent compound materials, the material symbols shall be preceded by the designation of the individual parts.

EXAMPLE

For a heel:

Exterior layer >EPDM<
Interior layer >NBR<

4.3 Recycling symbol

If a recycling system exists for the plastic parts, an additional symbol may also be allocated in the form of a closed triple-arrow symbol (see figure 2).

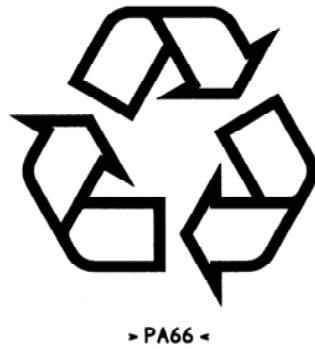

NOTE — This marking depends on the regulations in different countries where the product is sold.

Figure 2 — Example of a closed triple-arrow symbol

5 Method of marking

5.1 The marking shall be durable. It should be positioned such a way that it can easily be read from a part which has been removed. The marking shall be enclosed by arrow symbols > < in order to allow clear recognition.

5.2 The size, form and execution of material marking shall correspond to the marking used for part numbers and date. The marking of plastic parts should preferably be embossed.

Table 1 — Examples of basic polymers commonly used in the winter-sports equipment industry

Symbol	Designation
ABS	acrylonitrile/butadiene/styrene copolymer
EP	epoxy resin
PA6	polyamide with 6 C-atoms in the monomer block
PA11	polyamide with 11 C-atoms in the monomer block
PA12	polyamide with 12 C-atoms in the monomer block
PA66	polyamide with 2 monomer blocks of 6 C-atoms each
PBT	poly(butylene terephthalate)
PC	polycarbonate
PET	poly(ethylene terephthalate)
PF	phenolic formaldehyde resin
PMMA	poly(methyl methacrylate)
POM	polyoxymethylene, polyacetal
PP	polypropylene
PTFE	polytetrafluoroethylene
PUR	duroplastic polyurethane
PVC	poly(vinyl chloride)
SAN ¹⁾	styrene/acrylonitrile copolymer
TEEE	thermoplastic ether-ester elastomer
TPU	thermoplastic polyurethane

¹⁾ In Japan and the USA, the symbol "SAN" is a registered trademark; therefore in Japan and the USA, "AS" is used for styrene/acrylonitrile.

Table 2 — Symbols for filler and reinforcing materials

Symbol	Designation
GF	glass fibre
GM	glass mats
GB	glass balls
T	talcum
M	mineral reinforcement
WD	wood dust

Table 3 — Examples of elastomer basic polymers commonly used in the winter-sports equipment industry

Symbol ¹⁾	Designation
BR	butadiene rubber
CR	chloroprene rubber
EPDM	terpolymer of ethylene, propylene and a diene with the residual unsaturated portion of the diene in the side-chain
NBR	acrylonitrile butadiene rubber (nitrile rubber)
NR	isoprene rubber (natural rubber)
SBR	styrene butadiene rubber
¹⁾ Symbols are in accordance with ISO 1629.	

Annex A
(informative)

Examples of plastics currently used in the winter-sports equipment industry, with the appropriate abbreviations

Common name	Material	Abbreviation
Akulon	polyamide 6 with 45 % glass fibre	>PA6-GF45<
Apilon	thermoplastic polyurethane	>TPU<
Arnite	Poly(ethylene terephthalate)	>PET<
Crastin	Poly(butylene terephthalate)	>PBT<
Delrin	polyacetal homopolymer	>POM<
Desmopan	thermoplastic polyurethane	>TPU<
Elastollan	thermoplastic polyurethane	>TPU<
Grilamid	polyamide 12	>PA12<
Grilon	polyamide 6 copolymer	>PA6/X/X/-GF25<
Grilon	polyamide 6	>PA6<
Hytrel	thermoplastic ether-ester elastomer	>TEEE<
Latamid	polyamide 66 with 50 % glass fibre	>PA66-GF50<
Lexan	polycarbonate	>PC<
Lupolen	high-density polyethylene	>PE-HD<
Luran S	acrylonitrile/styrene/acrylate copolymer	>ASA<
Makrolon	polycarbonate	>PC<
Megol	styrene-ethylene-butylene-styrene blend	>SEBS+PP<
Nylon	polyamide 6 with 45 % glass fibre	>PA6-GF45<
Pebax	polyether block amide	>PEBA<
Polystyrene	high-impact polystyrene	>S/B<
Raplan	styrene-butadiene-styrene blend	>SBS + PS<
Styrolux	styrene/butadiene/styrene	>S/B/S<
Surlyn	polyethylene ionomers	>EMA<
Terluran	acrylonitrile/butadiene/styrene	>ABS<
Ultramid	polyamide 6 with 50 % glass fibre	>PA6-GF50<
Vestamid	polyamide 12	>PA12<
Vestamid	polyamide 12 with 30 % glass fibre	>PA12-GF30<

This page intentionally left blank

This page intentionally left blank

ICS 97.220.20

Descriptors: sports equipment, winter sports equipment, plastics products, components, marking, symbols.

Price based on 7 pages
