

First edition
1997-11-01

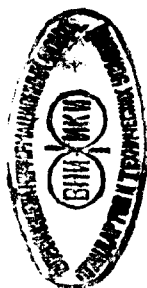

**Industrial wire screens — Technical
requirements and testing**

*Tissus métalliques préformés ou soudés — Exigences techniques et
vérifications*

UD 6-98
20



Reference number
ISO 14315:1997(E)

Contents

1 Scope	1
2 Normative references	1
3 Definitions	2
4 Requirements	3
5 Test methods.....	8
6 Inspection documents.....	10
7 Ordering information.....	10
8 Delivery	11

© ISO 1997

All rights reserved. Unless otherwise specified, no part of this publication may be reproduced or utilized in any form or by any means, electronic or mechanical, including photocopying and microfilm, without permission in writing from the publisher.

International Organization for Standardization
Case Postale 56 • CH-1211 Genève 20 • Switzerland
Internet central@iso.ch
X.400 c=ch; a=400net; p=iso; o=isocs; s=central

Printed in Switzerland

Foreword

ISO (the International Organization for Standardization) is a worldwide federation of national standards bodies (ISO member bodies). The work of preparing International Standards is normally carried out through ISO technical committees. Each member body interested in a subject for which a technical committee has been established has the right to be represented on that committee. International organizations, governmental and non-governmental, in liaison with ISO, also take part in the work. ISO collaborates closely with the International Electrotechnical Commission (IEC) on all matters of electrotechnical standardization.

Draft International Standards adopted by the technical committees are circulated to the member bodies for voting. Publication as an International Standard requires approval by at least 75 % of the member bodies casting a vote.

International Standard ISO 14315 was prepared by Technical Committee ISO/TC 24, *Sieves, sieving and other sizing methods*, Subcommittee SC 3, *Industrial wire screens*.

Industrial wire screens – Technical requirements and testing

1 Scope

This International Standard defines terms regarding metal wire screens for industrial screening purposes and specifies tolerances, requirements and test methods.

It is applicable to pre-crimped or pressure-welded wire screens in accordance with ISO 4783-3, made of high-tensile steel, stainless steel or other metal wires.

This International Standard is not applicable to industrial wire cloth in accordance with ISO 4783-2 (see ISO 9044:—¹), *Industrial woven wire cloth — Technical requirements and testing*).

2 Normative references

The following standards contain provisions which, through reference in this text, constitute provisions of this International Standard. At the time of publication, the editions indicated were valid. All standards are subject to revision, and parties to agreements based on this International Standard are encouraged to investigate the possibility of applying the most recent editions of the standards listed below. Members of IEC and ISO maintain registers of currently valid International Standards.

ISO 2194:1972, *Wire screens and plate screens for industrial purposes — Nominal sizes of apertures*.

ISO 4782:1989, *Metal wire for wire screens and industrial wire cloth*.

ISO 4783-1:1989, *Industrial wire screens and industrial wire cloth — Guide to the choice of aperture size and wire diameter combinations — Part 1: Generalities*.

ISO 4783-3:1981, *Industrial wire screens and industrial wire cloth — Guide to the choice of aperture size and wire diameter combinations — Part 3: Preferred combinations for pre-crimped or pressure-welded wire screens*.

1) To be published. (Revision of ISO 9044:1990)

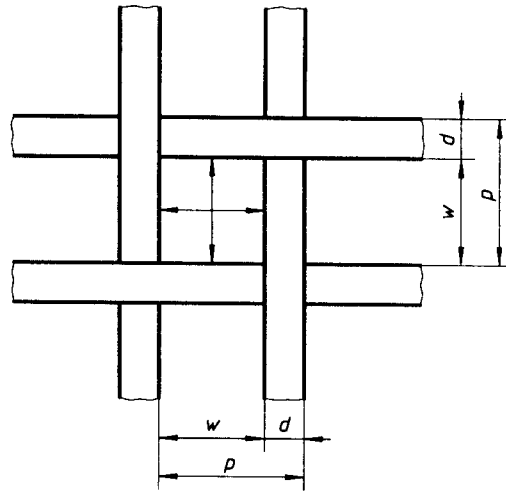

Figure 1 — Aperture width, wire diameter and pitch

3 Definitions

For the purposes of this International Standard, the following definitions apply.

3.1 aperture width, w

distance between two adjacent warp or weft wires, measured in the projected plane at mid positions (see figure 1)

3.2 wire diameter, d

diameter of the wire in the wire screen (see figure 1)

NOTE — The wire diameter may be altered slightly during the manufacturing process of the wire screen.

3.3 pitch, p

- 1) distance between the middle points of two adjacent wires
- 2) nominally the sum of the aperture width w and the wire diameter d (see figure 1)

3.4 warp

all wires running lengthwise in the screen as manufactured

3.5 weft

all wires running crosswise in the screen as manufactured

3.6 number of apertures per unit length, n

number of apertures which are counted in a row, one behind the other on a given unit length

3.7 open screening area, A_o

- 1) percentage of the surface of all the apertures in the total screening surface
- 2) ratio of the square of the nominal aperture width w and the square of the nominal pitch p

$p = (w+d)$, rounded to a full percentage value:

$$A_o = 100 \frac{w^2}{(w+d)^2}$$

(1)

3.8 type of screen

way in which the warp and weft wires are pre-crimped or connected to each other to form the screen (see ISO 4783-3:1981, table 1)

3.9 firmness of industrial wire screen

tension existing between the crossing warp and weft wires and which, together with the interlocking, determines the firmness of the wire screen

NOTE — It is affected by the tensile strength of the material, by the relationship of w to d , and by the type and the depth of the crimp.

3.10 mass per unit area, ρ_A

That quantity calculated using the following equation:

$$\rho_A = \frac{d^2 \cdot \rho \cdot f}{618,1 \cdot (w + d)} \quad (2)$$

where

d is the wire diameter, in millimetres;

w is the aperture width, in millimetres;

f is the type conversion factor (see ISO 4783-3:1981, table 1);

ρ is the material density, in kilograms per cubic metre (see ISO 4783-1:1989, table 2).

NOTE — Equation (2) gives the calculated mass per unit area (kg/m^2), although the actual value can be up to 3 % lower.

3.11 major blemishes

production defects which significantly affect the aperture size or surface quality of the wire screen

4 Requirements

For requirements on aperture widths, on the metal wire and on aperture width/wire diameter combinations for wire screens, see ISO 2194, ISO 4782, ISO 4783-1 and ISO 4783-3.

4.1 Tolerance on wire diameter

Prior to weaving, the tolerance on wire diameter shall be as specified in ISO 4782. The weaving process normally distorts the wire and affects its diameter. After weaving, the diameter of the wire is untoleranced. The wire diameter shall be measured as specified in 5.1.

4.2 Tolerances on aperture width

The tolerances on aperture width shall be as given in table 1.

NOTE In the following, the suffix "s" used with the symbols denotes "industrial wire screens".

4.2.1 Tolerance Y_s : Average aperture size

Y_s is the tolerance of the arithmetical mean value of the aperture widths measured and calculated separately in both warp and weft directions. The arithmetical average aperture size shall not deviate from the nominal size by more than $\pm Y_s$.

4.2.2 Tolerance X_s : Maximum aperture size

No aperture size shall exceed the nominal size by more than the value X_s . This is the maximum permissible deviation of a single aperture measured separately in both warp and weft directions.

Since, on the basis of experience, negative deviations of single aperture widths do not affect the screening process, values for X_s have only positive deviations.

Table 1 — Tolerances on aperture width

Nominal aperture width w mm	Tolerances on aperture width	
	$\pm Y_s$ %	$+X_s$ %
$125 \geq w > 63$	2,5	5
$63 \geq w > 31,5$	3	7
$31,5 \geq w > 16$	3,5	8
$16 \geq w > 8$	4	10
$8 \geq w > 4$	5	13
$4 \geq w > 2$	5	16
$2 \geq w \geq 1$	5	20

4.3 Permissible number of major blemishes

4.3.1 Wire screens cannot be produced commercially without there being some manufacturing blemishes. The manufacturer and the customer shall agree upon the number and nature of major blemishes which are permissible per unit area of the wire screen. The percentage of yield of the screen shall be agreed on with the customer and will vary according to the size of the piece of wire screen.

4.3.2 Unless otherwise agreed, the number of major blemishes as given in table 2 shall not be exceeded.

Table 2 — Permissible number of major blemishes

Nominal aperture width w mm	Maximum number of major blemishes per 10 m ²
$125 \geq w > 63$	2
$63 \geq w > 31,5$	3
$31,5 \geq w > 16$	4
$16 \geq w > 8$	5
$8 \geq w > 4$	6
$4 \geq w > 2$	8
$2 \geq w \geq 1$	10

4.3.3 For cut-to-size pieces, the permissible number of major blemishes and their positions shall be agreed with the customer. Otherwise, the permissible number of major blemishes in cut-to-size pieces shall be as given in table 2.

4.3.4 Minor manufacturing blemishes which do not produce oversize apertures or significantly affect the surface quality of the wire screen shall be acceptable unless otherwise specified.

4.4 Flatness of wire screens

Wire screens may be curled in the warp and/or weft direction; the absolute flatness of the screen cannot be guaranteed.

4.5 Surface conditions

Wire screens may be covered with a film of oil as a result of the manufacturing process.

The wires may show traces of auxiliary materials used in the drawing process. Depending on the wire material, there may be traces of corrosion.

The surface may show markings caused by drawing, crimping or other processes of manufacture.

NOTE — The depth of crimp may differ between warp and weft wires.

4.6 Rectangular screening surfaces from wire screens

4.6.1 General

Rectangular screening surfaces can be manufactured from wire screens as cut-to-size pieces with or without hook strips for fixing in a screen frame with optimum tension.

The overall dimensions of screening surfaces are designated as

- a) in the direction parallel to the flow of the material to be screened, and
- b) in the direction across the flow of the material to be screened (see figure 2).

4.6.2 Tolerances on screening surfaces without hook strips

The tolerances on the nominal length and width of screening surfaces without hook strips shall be as given in table 3.

Table 3 — Tolerances on screening surfaces without hook strips

Dimension <i>a</i> or <i>b</i> mm	Tolerance*) mm
$4000 \geq a, b > 2000$	$\pm (6 + d)$
$2000 \geq a, b > 1000$	$\pm (3 + d)$
$1000 \geq a, b > 300$	$\pm (2 + d)$
$300 \geq a, b$	$\pm (1,5 + d)$
*) <i>d</i> = wire diameter	

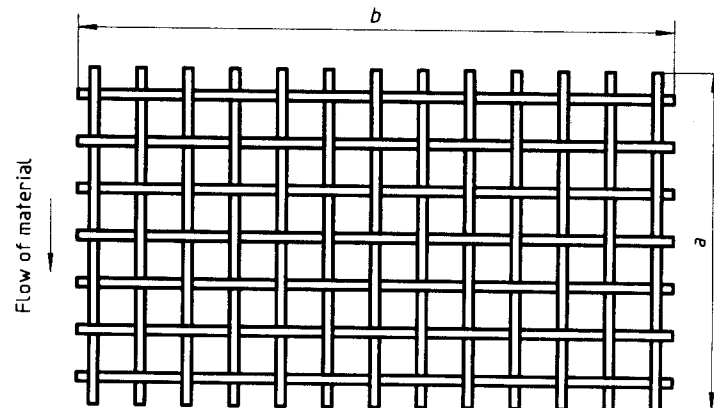

Figure 2 — Dimensions of screening surfaces

4.6.3 Tolerances on screening surfaces with hook strips

Screening surfaces can be tensioned by hook strips

— across (side tensioning), see figure 3, or

— parallel (end tensioning), see figure 4,

to the direction of the flow of the material being screened. The dimension of the screening surface between the hook strips is designated as

- b_{ho} for side tensioning with upward bent hook strips,
- a_{hi} for end tensioning with downward bent hook strips or with one downward and one upward bent hook strip,
- a_{hio} for end tensioning with a downward bent hook strip at one end and a flat tensioning bar at the other end, see figure 4.

Dimensions in millimetres

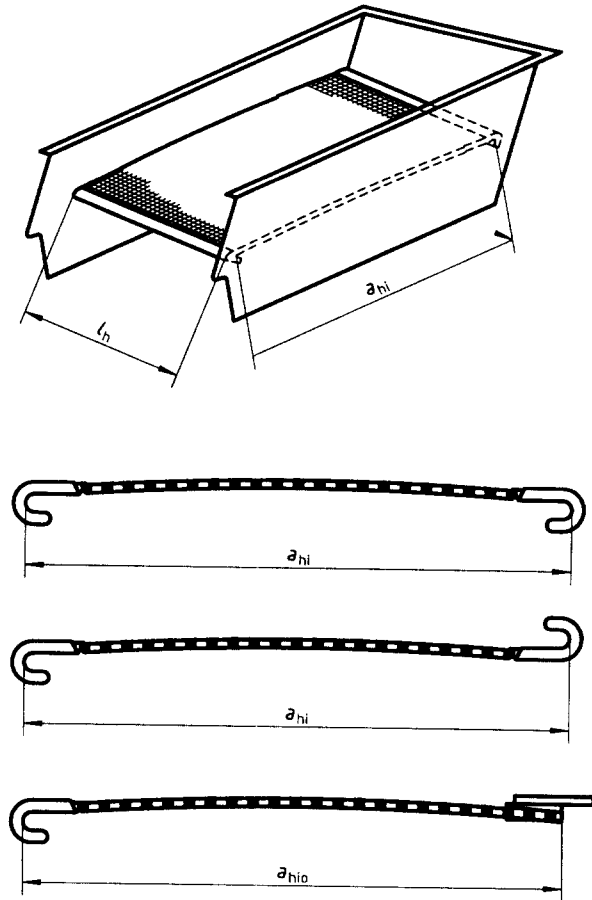
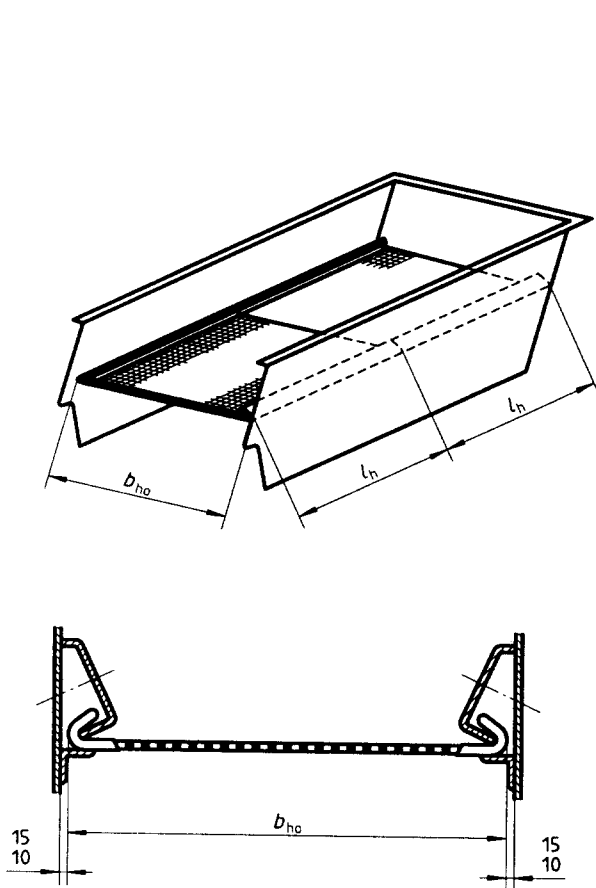

NOTE — Between the outside of the hook strip and the inside of the side plate a space of between 10 mm and 15 mm is necessary.

Figure 3 — Side tensioning

Figure 4 — End tensioning

Table 4 — Screening surfaces with hook strips, tolerances and measurement

Dimension symbol	Tolerance*) mm	Measurement
b_{ho}	0 $-(8+d)$	between outsides of the hook strips (side tensioning)
a_{hi}	$+(8+d)$ 0	between insides of the hook strips (end tensioning)
a_{hio}	$+(8+d)$ 0	between inside of downward bent hook strip and outside of flat bent tensioning bar (end tensioning)
l_h	0 $-(5+2d)$	overall length of hook strips
Δ_p	± 4 mm per 1000 mm length	parallelism of hook strips

*) d = wire diameter.

The length of the hook strips shall comply with the other dimensions of the screening surface and is designated as h .

The deviation of the parallelism of the hook strips is designated Δ_p .

The tolerances and the measurement for the dimensions of screening surfaces with hook strips shall be as given in table 4.

4.7 Material

The wire of wire screens shall be from

- a) high-tensile steel with carbon content between 0,37 % and 0,85 % hard drawn, tensile strength in relation to the wire diameter from 900 N/mm² to 2 000 N/mm²; or
- b) stainless steel, the type of alloy to be specified by the customer; or
- c) other weavable metals to be agreed upon.

Materials should be designated in accordance with appropriate standards or, if none exists, according to commercial specifications.

5 Test methods

5.1 Wire diameter, d

The wire diameter shall be determined either by measuring the wire in the wire screen if there is sufficient space for the measuring instrument, or by measuring a wire which has been loosened from the wire screen; see figures 5 and 6.

5.2 Aperture width, w

5.2.1 Average aperture size, Y_s (see 4.2.1)

The aperture widths shall be measured separately in the warp and weft directions.

For a full roll of 30 m length, measure the number of apertures as stated under a), b) and c). An equivalent number of apertures shall be measured in parts of rolls and in cut-to-size pieces.

- a) $125 \text{ mm} \geq w > 16 \text{ mm}$

Measure five individual apertures; see figure 5.

- b) $16 \text{ mm} \geq w > 4 \text{ mm}$

Lay a steel rule, graduated in millimetres, along the warp and weft directions of the wire screen. Measure the span of 10 pitches to the nearest millimetre. Divide the test result by 10 to give the average pitch. Subtract the nominal wire diameter to give the average aperture size; see figure 7.

- c) $4 \text{ mm} \geq w \geq 1 \text{ mm}$

The test procedure shall be as in b) but the span of 20 pitches shall be measured and the test result divided by 20 to give the average pitch.

5.2.2 Maximum aperture size, X_s (see 4.2.2)

When evaluating the test results, a margin of 10 mm on both sides of the roll and, for aperture widths exceeding 5 mm, a margin equivalent to two apertures on each side shall be disregarded.

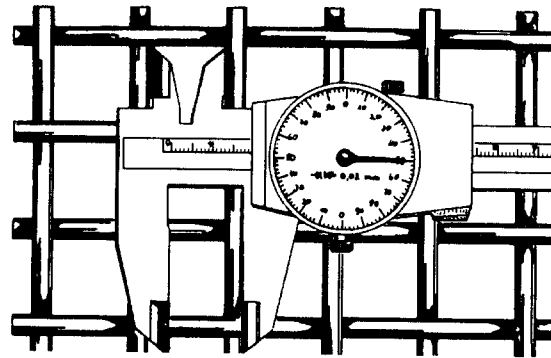

Figure 5 — Dial gauge caliper

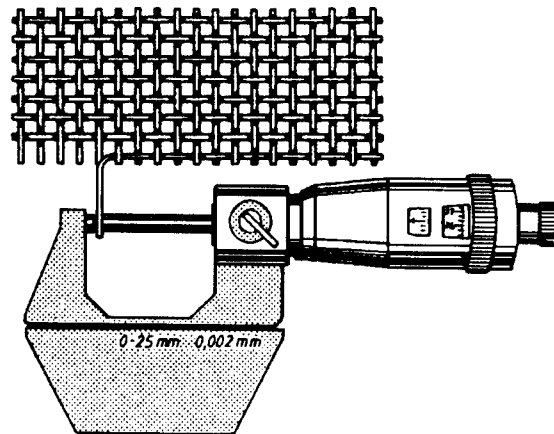

Figure 6 — Micrometer

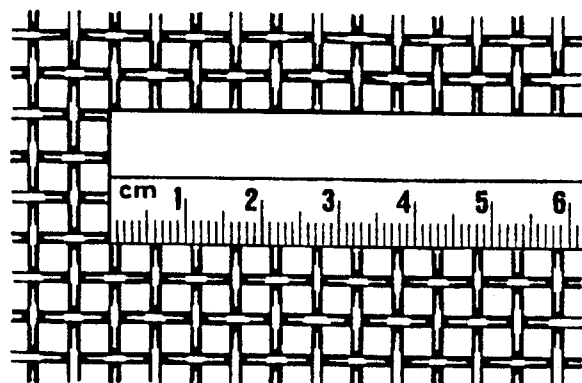

Figure 7 — Measured row with 10 pitches and 52,5 mm length

6 Inspection documents

6.1 Statement of compliance with the order

The statement of compliance shall confirm that the goods comply with the requirements of this International Standard.

6.2 Test report

The test report shall confirm that the goods comply with the requirements of this International Standard, as verified by the supplier's independently assessed and approved quality assurance system.

6.3 Inspection certificate

At the specific request of the purchaser, a certificate shall be issued stating separately the test results for the average aperture size and wire diameter, both in the warp and weft directions of the wire cloth.

6.4 Chemical analysis

Chemical analysis of the wire material shall be reported, or the wire drawer's or wire processor's batch or melt number analysis.

6.5 Other tests

Dimension or other tests shall be carried out in accordance with the supplier's inspection procedures, unless otherwise agreed with the purchaser.

7 Ordering information

7.1 Essential information

It is essential that the following information is given by the purchaser to the supplier at the time of enquiry or order to assist the supplier in providing the correct material.

- a) The quantity required, size of pieces or rolls.
- b) Aperture size w .
- c) Wire diameter d .
- d) Material, if other than high-tensile steel (see 4.7).
- e) Type of weave, if other than type A, see ISO 4783-3:1981, table 1.
- f) Tolerances for pieces, if other than those specified in table 3 or 4.

7.2 Additional information

The purchaser should also be aware of the need to include the following information in the enquiry and order if required.

- a) Whether a test certificate is required, and the type of test certificate. If no request is made, a statement of compliance may be provided.
- b) Whether additional requirements not specified in this International Standard are required.

8 Delivery

8.1 Rolls

8.1.1 The length of a roll depends on the wire diameter and shall be agreed between the manufacturer and customer. The tolerances on the agreed length shall be $+10_{-5}\%$. The delivered length shall be the length invoiced.

8.1.2 A roll may consist of a maximum of three roll pieces; the minimum length of a roll piece shall be 5 m.

8.1.3 For rolls and roll pieces, the tolerance on the width shall be $+2_0\%$.

8.2 Cut-to-size pieces

See figures 2 and 3.

8.3 Packing

Unless otherwise agreed between supplier and purchaser, the industrial wire screens shall be packed at the discretion of the supplier.

8.4 Labelling

Material supplied shall be identified with the following information.

- a) Supplier's name and/or trademark.
- b) Aperture size (nominal).
- c) Wire diameter (nominal).
- d) Material designation.
- e) Type of weave.
- f) Size and quantity.

14

ICS 73.120

Descriptors: sieves, metal nettings, sizing screens, dimensions, tests, determination, openings, delivery condition.

Price based on 11 pages
