

First edition
2011-09-15

**Rubber, vulcanized or thermoplastic —
Determination of volume and/or surface
resistivity**

*Caoutchouc vulcanisé ou thermoplastique — Détermination de la
résistivité transversale et/ou superficielle*



Reference number
ISO 14309:2011(E)

© ISO 2011



COPYRIGHT PROTECTED DOCUMENT

© ISO 2011

All rights reserved. Unless otherwise specified, no part of this publication may be reproduced or utilized in any form or by any means, electronic or mechanical, including photocopying and microfilm, without permission in writing from either ISO at the address below or ISO's member body in the country of the requester.

ISO copyright office
Case postale 56 • CH-1211 Geneva 20
Tel. + 41 22 749 01 11
Fax + 41 22 749 09 47
E-mail copyright@iso.org
Web www.iso.org

Published in Switzerland

Contents

Page

Foreword	iv
Introduction	v
1 Scope	1
2 Normative references	1
3 Terms and definitions	1
4 Principle	2
5 Apparatus	2
6 Calibration	5
7 Test pieces	5
7.1 Form of test piece	5
7.2 Number of test pieces	6
8 Conditioning	6
9 Test conditions	6
9.1 Temperature and humidity	6
9.2 Applied voltage	6
10 Test procedure	6
11 Expression of results	7
11.1 Volume resistivity	7
11.2 Surface resistivity	7
12 Test report	8
Annex A (informative) Electrode materials	9
Annex B (informative) Suitable range of test conditions	10
Annex C (normative) Calibration schedule	12
Bibliography	14

Foreword

ISO (the International Organization for Standardization) is a worldwide federation of national standards bodies (ISO member bodies). The work of preparing International Standards is normally carried out through ISO technical committees. Each member body interested in a subject for which a technical committee has been established has the right to be represented on that committee. International organizations, governmental and non-governmental, in liaison with ISO, also take part in the work. ISO collaborates closely with the International Electrotechnical Commission (IEC) on all matters of electrotechnical standardization.

International Standards are drafted in accordance with the rules given in the ISO/IEC Directives, Part 2.

The main task of technical committees is to prepare International Standards. Draft International Standards adopted by the technical committees are circulated to the member bodies for voting. Publication as an International Standard requires approval by at least 75 % of the member bodies casting a vote.

Attention is drawn to the possibility that some of the elements of this document may be the subject of patent rights. ISO shall not be held responsible for identifying any or all such patent rights.

ISO 14309 was prepared by Technical Committee ISO/TC 45, *Rubber and rubber products*, Subcommittee SC 2, *Testing and analysis*.

Introduction

Rubber materials are widely used in many industries, either as the major material or forming a part of the product, because of their unique physical properties which can be tailored by compounding to match the particular requirements of the product specification. Although rubbers are generally regarded as insulating materials, they can be made electrically conductive or dissipative by compounding with a certain amount of carbon black or ionizable ingredients. Hence, the range of electrical resistance to be measured is very wide. It is difficult, however, to obtain high accuracy for measurements in the high-resistance range due to a number of factors.

In this International Standard, the guarded-electrode system is used to determine the resistivity of rubber test pieces since it is considered a good compromise between minimizing the errors by shunting away stray currents and using more unwieldy measurement instruments (see also IEC 60093).

ISO 1853, on the other hand, covers rubber materials with medium to low resistance, i.e. resistivities of 10^{10} $\Omega\cdot\text{m}$ or below. It specifies three methods for determining volume resistivity which minimize or eliminate contact resistance.

The methods specified in this International Standard were originally designed for the determination of both surface and volume resistivity of insulating rubber materials, but their use can be extended to cover the range from high to low resistivity.

It is known that the test results are sensitive to the test conditions, such as temperature and humidity, and to heat and strain history.

Rubber, vulcanized or thermoplastic — Determination of volume and/or surface resistivity

WARNING — Persons using this International Standard should be familiar with normal laboratory practice. This standard does not purport to address all of the safety problems, if any, associated with its use. It is the responsibility of the user to establish appropriate safety and health practices and to ensure compliance with any national regulatory conditions.

IMPORTANT — Certain procedures specified in this International Standard might involve the use or generation of substances, or the generation of waste, that could constitute a local environmental hazard. Reference should be made to appropriate documentation on safe handling and disposal after use.

1 Scope

This International Standard specifies a method for the determination of the volume and the surface resistivity of vulcanized or thermoplastic rubbers. The method can be applied to materials with a resistivity from $10^1 \Omega\cdot\text{m}$ to $10^{17} \Omega\cdot\text{m}$.

2 Normative references

The following referenced documents are indispensable for the application of this document. For dated references, only the edition cited applies. For undated references, the latest edition of the referenced document (including any amendments) applies.

ISO 1382, *Rubber — Vocabulary*

ISO 18899:2004, *Rubber — Guide to the calibration of test equipment*

ISO 23529, *Rubber — General procedures for preparing and conditioning test pieces for physical test methods*

3 Terms and definitions

For the purposes of this document, the terms and definitions given in ISO 1382 and the following apply.

3.1

volume resistance

R_v

quotient of a direct-current voltage applied between two electrodes in contact with opposite faces of a test piece and the current between the electrodes, excluding current along the surface

NOTE It is expressed in ohms (Ω).

3.2

surface resistance

R_s

quotient of a direct-current voltage applied between two electrodes on the same surface of a test piece and the current between the electrodes

NOTE It is expressed in ohms (Ω).

3.3 volume resistivity

ρ_V
measured volume resistance calculated to apply to a cube of unit side

NOTE It is expressed in ohm metres ($\Omega \cdot m$).

3.4 surface resistivity

ρ_s
measured surface resistance calculated to apply to a square

NOTE It is expressed in ohms (Ω) and the size of the square is immaterial.

3.5 guarded-electrode system

electrode system composed of three electrodes, a guard, and a guarded and an unguarded electrode to reduce measurement errors by protecting the current-measuring electrode from the interfering influences of voltages other than the test voltage, and of stray conductances

NOTE Guarding depends on interposing, in all critical insulated parts, guard electrodes which intercept all stray currents that might otherwise cause errors. The guard electrodes are connected together, constituting the guard system and forming with the measurement terminals a three-terminal network. When suitable connections are made, stray currents from spurious external voltages are shunted away from the measurement circuit by the guard system, the insulation resistance from either measurement terminal to the guard system shunts a circuit element which should be of very much lower resistance, and the specimen resistance constitutes the only direct path between the measurement terminals. By this technique, the probability of error is considerably reduced (see 5.3 of IEC 60093:1980 for more details).

4 Principle

The volume and surface resistances of a rubber test piece are determined, using a suitable arrangement of electrodes, from the current flowing when a voltage is applied. The volume and surface resistivities are calculated from the measured resistances, which include the contact resistance.

5 Apparatus

The test equipment consists of a power supply, current-measuring equipment and electrodes, as follows:

5.1 Stabilized direct-current power supply, capable of applying a voltage of 1 V to 1 000 V to the test piece.

5.2 Voltmeter, capable of measuring the applied voltage with an accuracy of ± 2 %.

5.3 Ammeter or other current-measuring device, capable of measuring a current of 0,01 pA to 100 mA, depending on the resistivity of the test piece to be measured. The accuracy of the current-measuring device shall be better than 5 %.

5.4 Electrodes, as follows:

5.4.1 Guarded-electrode system

Three electrodes shall be applied to the test piece:

- a main electrode (circular);
- a ring electrode (annular);
- an opposed electrode (circular).

5.4.2 Shapes and dimensions of electrodes

The main (smallest) electrode is circular and is surrounded by the ring electrode. The third electrode is circular and placed on the opposite side of the test piece to the main electrode. The arrangement of the electrodes is shown schematically in Figure 1. The dimensions of the electrodes shall comply with following requirements:

- The diameter D_1 of the main electrode shall be at least ten times the test piece thickness h .
- The gap g between the main electrode and the ring electrode shall be uniform in width. For the measurement of volume resistivity, it should preferably be as narrow as possible so that surface leakage does not cause any error in the measurement. In practice, it is usually 1 mm or larger. For the measurement of surface resistivity, it shall be at least twice the test piece thickness so that the effect of the volume resistance can be ignored.
- The width of the ring electrode shall be greater than the test piece thickness h .
- The diameter D_4 of the opposed electrode shall be greater than the outer diameter D_3 of the ring electrode.

A typical example is as follows:

D_1 (50 ± 0,5) mm

D_2 (70 ± 0,5) mm

D_3 (80 ± 0,5) mm

D_4 (83 ± 2) mm

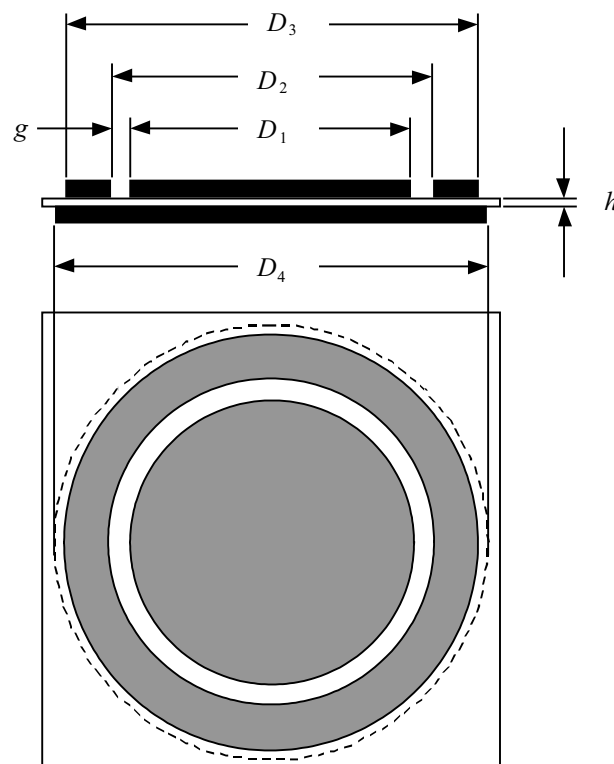

Figure 1 — Arrangement of electrodes

5.4.3 Electrode materials

Electrodes shall be of a conducting material capable of being intimately applied to the test piece. If they are applied before conditioning, the material shall be moisture-permeable. Electrodes other than of rigid metal shall be supplemented by rigid metal backing plates.

NOTE Suitable electrode materials are considered in Annex A.

5.4.4 Electrical circuits

Suitable circuits for testing are shown in Figures 2 and 3.

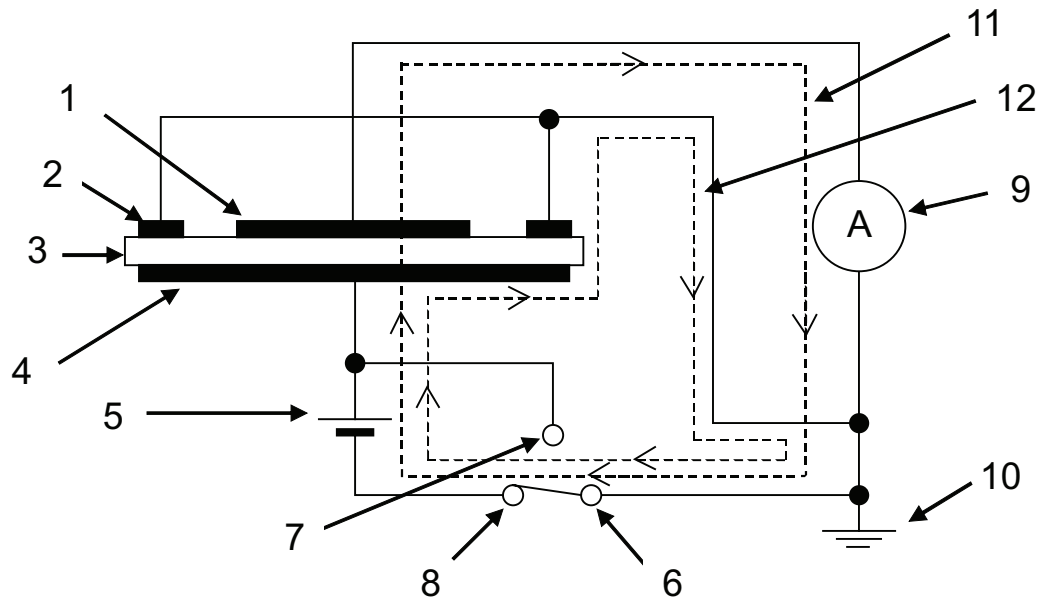

Key

- 1 guarded electrode (main electrode)
- 2 guard electrode (ring electrode)
- 3 test piece
- 4 unguarded electrode (opposed electrode)
- 5 direct-current supply
- 6 switch
- 7 connection for short-circuiting electrodes (to discharge test piece)
- 8 connection for measurement circuit
- 9 ammeter
- 10 earth
- 11 measurement current
- 12 guard current

Figure 2 — Circuit configuration for volume resistivity

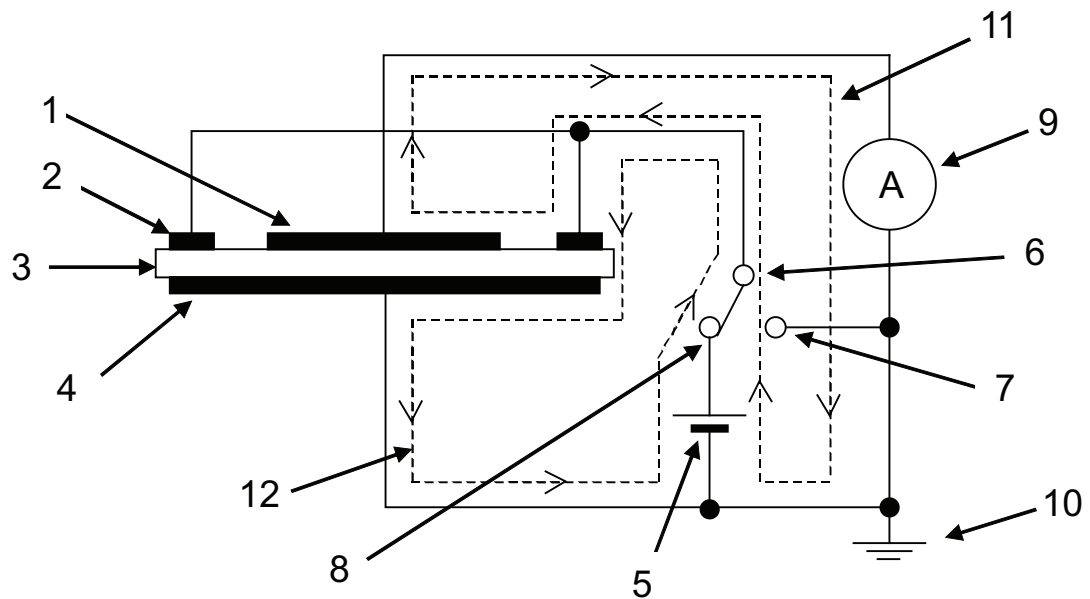

Key

- 1 guarded electrode (main electrode)
- 2 unguarded electrode (ring electrode)
- 3 test piece
- 4 guard electrode (opposed electrode)
- 5 direct-current supply
- 6 switch
- 7 connection for short-circuiting electrodes (to discharge test piece)
- 8 connection for measurement circuit
- 9 ammeter
- 10 earth
- 11 measurement current
- 12 guard current

Figure 3 — Circuit configuration for surface resistivity

6 Calibration

The requirements for calibration of the test apparatus are given in Annex C.

7 Test pieces

7.1 Form of test piece

The test piece shall be a flat, smooth sheet of sufficient size that the annular electrode does not reach its edges. The surfaces of the sheet shall not be buffed.

The nominal thickness of the test piece shall be in the range 0,5 mm to 5 mm, preferably 1 mm or 2 mm.

The thickness of the test piece shall be measured at several points distributed uniformly over the area covered by the main electrode to the nearest 0,01 mm. The average value shall be used as the test piece thickness. The variation in thickness within a given test piece shall not exceed 10 % of the mean value. Test pieces used for comparative tests shall be, as nearly as practicable, of the same thickness.

7.2 Number of test pieces

Three test pieces shall be used.

8 Conditioning

The time interval between vulcanization and testing shall be in accordance with ISO 23529.

Samples and test pieces shall be stored in accordance with ISO 23529 during the interval between vulcanization and testing.

The material shall be conditioned before testing for a minimum of 16 h at standard laboratory temperature and humidity as specified in ISO 23529.

Metal foil, liquid and conductive elastomeric electrodes shall be applied after conditioning. This shall be carried out either in the conditioning atmosphere or as soon as possible after removal from the conditioning atmosphere. Moisture-permeable electrodes can be applied before conditioning.

For a material which has a resistivity of more than $10^6 \Omega\cdot\text{m}$, short-circuit two metal plates placed on either side of the test piece during conditioning to avoid the effects of residual charge.

9 Test conditions

9.1 Temperature and humidity

Tests are normally performed at a standard laboratory temperature as defined in ISO 23529, although elevated or subnormal temperatures can be used. In the latter case, the test temperature shall be selected from the list in ISO 23529.

With materials for which the results are known to be sensitive to humidity, the test shall be carried out under standard laboratory conditions (temperature and humidity) as defined in ISO 23529.

NOTE An influence of humidity has been observed with polyurethane rubbers and other rubbers containing hydrophilic fillers.

9.2 Applied voltage

The test voltage applied to the test piece shall be in the range 1 V to 1 000 V. The voltage shall be selected in consideration of the resistivity of the test piece and rated current of the ammeter. The power dissipated in the test piece shall not exceed 0,1 W, in order to minimize heat generation. Recommended voltages are 1 V, 10 V, 100 V, 500 V and 1 000 V. Suitable test conditions are given in Annex B.

NOTE Setting the dissipation of electric power at less than 0,1 W is based on the estimation of the heat generated. Assuming that dissipation of electric power within a test piece is 1 W, 60 J is generated during a 60 s current application. Supposing that the mass of the rubber in the heat generation area and the specific heat of the rubber are 3 g and 2 000 J·kg·K, respectively, and that all the heat generated acts to raise the temperature of the test piece, the resulting temperature rise is approximately 10 K. In practice, heat is dissipated out of the test piece and the actual temperature rise will be less than that calculated. If the dissipation power is limited to 0,1 W, the temperature rise is estimated to be approximately 1 K, which can be considered negligible.

10 Test procedure

Measure the electrode dimensions and the width of the gap g to the nearest 0,05 mm.

Apply the electrodes, ensuring that there is intimate contact with the test piece over the entire electrode area. Take care to avoid excessive pressure since the test result can be affected by deformation of the test piece. When conductive paint electrodes are used, ensure that the film is not damaged and not separated from the test piece.

Connect up the electrodes, current-measuring device and power supply as shown in Figure 2 or 3 for volume or surface resistivity measurement, respectively.

Short-circuit the guarded electrode and the unguarded electrode, as indicated in Figures 2 and 3, such that any residual charge on and in the test piece is eliminated. This operation shall be carried out on all conditioned test pieces, including those that have been discharged by sandwiching them between metal plates during conditioning.

Reconnect the electrodes as appropriate for the measurement of the volume or surface resistivity, and then apply the specified voltage. Measure the current between the guarded electrode and the unguarded electrode 1 min after applying the voltage.

Before carrying out a further measurement on the same test piece, repeat the discharging process. For a material which has a resistivity of more than 10^6 W·m, this shall include the discharging process carried out during conditioning.

11 Expression of results

11.1 Volume resistivity

Calculate the volume resistivity from the following equation:

$$\rho_v = \frac{\pi \times D_1^2}{4 \times h} \times R_v = \frac{\pi \times D_1^2 \times V}{4 \times h \times I_v}$$

where

ρ_v is the volume resistivity, in $\Omega \cdot m$;

R_v is the volume resistance, in Ω ;

D_1 is the diameter of the guarded electrode, in m;

h is the thickness of the test piece, in m;

V is the voltage applied, in V;

I_v is the current measured 1 min after application of the voltage, in A.

11.2 Surface resistivity

Calculate the surface resistivity from the following equation:

$$\rho_s = \frac{\pi(D_2 + D_1)}{D_2 - D_1} \times R_s = \frac{\pi(D_2 + D_1) \times V}{(D_2 - D_1) \times I_s}$$

where

ρ_s is the surface resistivity, in Ω ;

R_s is the surface resistance, in Ω ;

D_1 is the diameter of the guarded electrode, in m;

D_2 is the inner diameter of the ring electrode, in m;

V is the voltage applied, in V;

I_s is the current measured 1 min after application of the voltage, in A.

12 Test report

The test report shall include the following information:

- a) sample details:
 - 1) a full description of the sample and its origin,
 - 2) the method of preparation of the test pieces from the sample, for example moulded or cut;
- b) the number of this International Standard;
- c) test details:
 - 1) the laboratory temperature,
 - 2) the time, temperature and humidity of conditioning prior to the test,
 - 3) the temperature and relative humidity of the test, if other than the temperature and relative humidity used to condition the test pieces,
 - 4) the dimensions and material of the electrodes used,
 - 5) the voltage applied to the test piece,
 - 6) details of any procedures not specified in this International Standard;
- d) test results:
 - 1) the individual values of the volume and/or surface resistivity for each test piece,
 - 2) the median value of the volume and/or surface resistivity;
- e) the date of the test.

Annex A (informative)

Electrode materials

Characteristics of suitable electrode materials are given in Table A.1.

Table A.1 — Characteristics of suitable electrode materials

Material	Feature	Precautions to be taken
Metal	<p>Stainless steel is typically used to form the electrodes.</p> <p>One commercially available electrode system is in the form of an electrically sealed box with the three electrodes fixed in position and a control system to change the contact pressure.</p> <p>Alternatively, the electrodes can be in the form of metal foil.</p>	<p>Contact with the test piece is ensured by the pressure on the electrodes, but excessive pressure might change the measured resistance. Generally, the contact of metal electrodes needs to be improved by the application of a thin layer of a material such as conductive paint or grease.</p>
Conductive paint	<p>A thin film of conductive silver paint or a suspension of colloidal graphite is applied to the test piece and allowed to dry.</p> <p>This has the advantage that sufficiently intimate contact is made even on rough surfaces.</p>	<p>If the test piece surface is contaminated as a result of blooming or bleeding, it should be cleaned before applying the paint.</p> <p>The test should be carried out relatively soon after application of the paint to avoid any peeling of the paint or blooming or bleeding between the electrodes and the test piece surface.</p>
Conductive rubber	<p>The electrodes are formed from conductive elastomeric sheet.</p>	<p>These electrodes require appreciable pressure to give intimate contact and, hence, are more suited to tests on rigid materials. Because the volume resistivity of a conductive rubber is usually $1 \Omega\cdot\text{m}$ to $10^1 \Omega\cdot\text{m}$, elastomeric electrodes should only be used on material of relatively high volume resistivity, preferably more than $10^6 \Omega\cdot\text{m}$.</p>

Annex B (informative)

Suitable range of test conditions

B.1 General

It is necessary that the applied voltage be adjusted to a level appropriate to the test piece resistance. This is important in order to prevent abnormal heat generation resulting from an excess of power dissipated in the test piece. It is also important that the current-measuring device have a sensitivity appropriate to the current level to be measured.

B.2 Suitable range for testing

B.2.1 General

The shaded area in Figure B.1 shows the range over which testing can be carried out using a guarded electrode of diameter 50 mm and a 2 mm thick test piece. The volume resistivity ρ_v is then $0,98R_v$. The applied voltage ranges from 1 V to 1 000 V. The range of volume resistivities which can be measured is limited by the need to use a current-measuring device with a detection limit between 0,01 pA and 100 mA and the need to keep the power dissipated in the test piece to a maximum of 0,1 W.

B.2.2 Minimum and maximum volume resistivity which can be measured

B.2.2.1 Minimum volume resistivity which can be measured

Using the minimum applied voltage of 1 V and with the power W dissipated in the test piece restricted to less than 0,1 W, the minimum resistance which can be measured is 10Ω ($R = V^2/W = 1^2/0,1 = 10$). The minimum volume resistivity which can be measured using the electrode and test piece dimensions given in B.2.1 is therefore $10^1 \Omega\cdot\text{m}$.

B.2.2.2 Maximum volume resistivity which can be measured

When measuring a relatively high-resistance test piece, a commercially available galvanometer or ammeter can readily measure a current of 0,01 pA. With the applied voltage set to the maximum of 1 000 V, the maximum resistance which can be measured is $1\,000\text{ V}/0,01\text{ pA}$, i.e. $10^{17} \Omega$. As a result, the maximum volume resistivity which can be measured is $10^{17} \Omega\cdot\text{m}$.

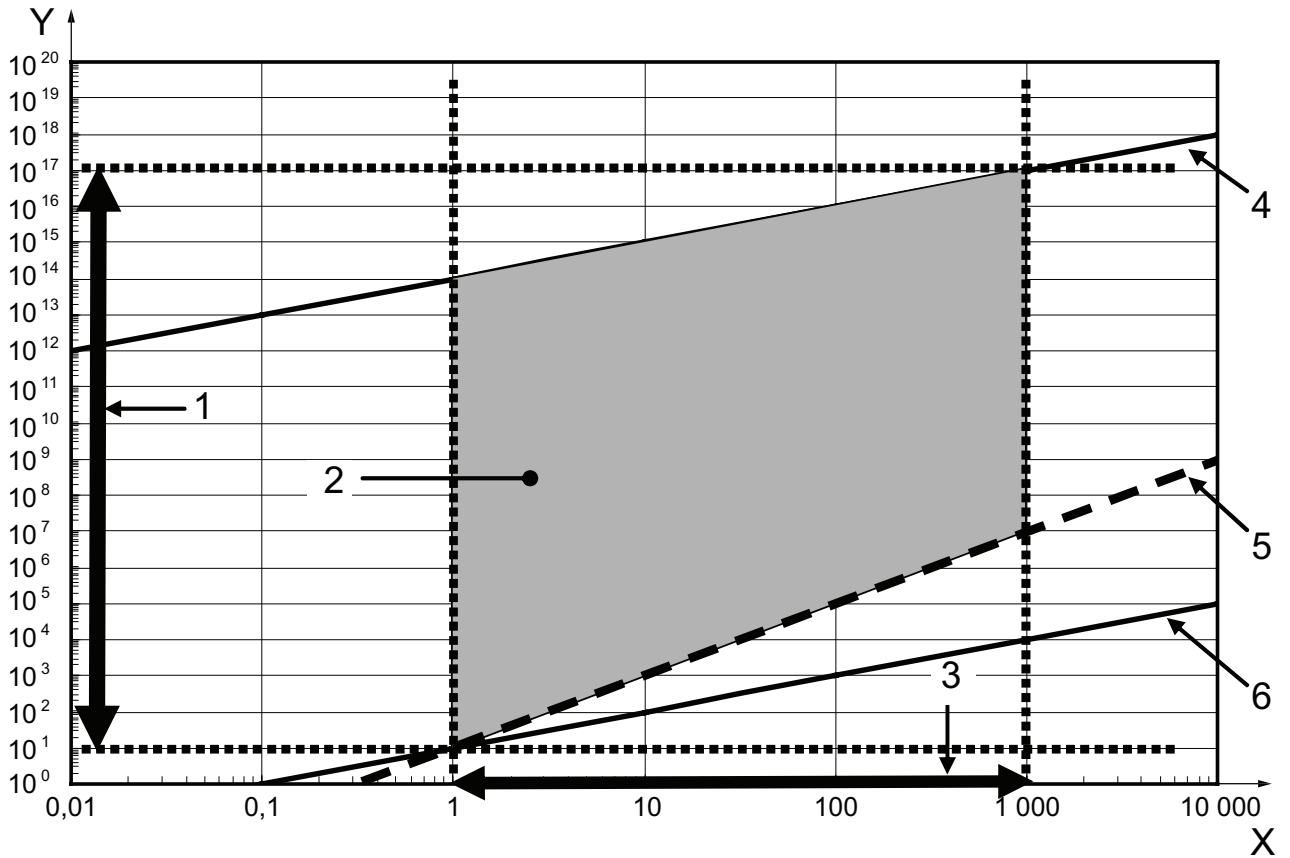

Key

- X applied voltage V , in V
- Y volume resistivity ρ_v , in $\Omega\cdot m$
- 1 suitable volume-resistivity range
- 2 measurement area
- 3 applied-voltage range
- 4 detection limit with an ammeter accurate to 0,01 pA
- 5 limit to keep the dissipated power below 0,1 W
- 6 detection limit with an ammeter accurate to 100 mA

Figure B.1 — Suitable range of test conditions

Annex C (normative)

Calibration schedule

C.1 Inspection

Before any calibration is undertaken, the condition of the items to be calibrated shall be ascertained by inspection and recorded in any calibration report or certificate. It shall be reported whether calibration is carried out in the “as-received” condition or after rectification of any abnormality or fault.

It shall be ascertained that the apparatus is generally fit for the intended purpose, including any parameters specified as approximate and for which the apparatus does not therefore need to be formally calibrated. If such parameters are liable to change, then the need for periodic checks shall be written into the detailed calibration procedures.

C.2 Schedule

Verification/calibration of the test apparatus is a mandatory part of this International Standard. However, the frequency of calibration and the procedures used are, unless otherwise stated, at the discretion of the individual laboratory, using ISO 18899 for guidance.

The calibration schedule given in Table C.1 has been compiled by listing all of the parameters specified in the test method, together with the specified requirement. A parameter and requirement can relate to the main test apparatus, to part of that apparatus or to an ancillary apparatus necessary for the test.

For each parameter, a calibration procedure is indicated by reference to ISO 18899, to another publication or to a procedure particular to the test method which is detailed (whenever a calibration procedure more specific or detailed than that in ISO 18899 is available, it shall be used in preference).

The verification frequency for each parameter is given by a code-letter. The code-letters used in the calibration schedule are:

- N initial verification only;
- S standard interval selected as given in ISO 18899.

Table C.1 — Calibration frequency schedule

Parameter	Requirement	Subclause in ISO 18899:2004	Verification frequency guide	Notes
Voltage (1 V to 1 000 V)	± 2 %	14.2	S	
Current (0,01 pA to 100 mA)	Better than 5 %	14.1	S	
Diameter D_1 of main electrode	At least ten times the test piece thickness h	15.2	N	The electrode dimensions and the width of the surface gap g shall be measured to the nearest 0,05 mm.
Gap g between main and ring electrodes	At least twice the test piece thickness h			
Width of ring electrode	Greater than the test piece thickness h			
Diameter D_4 of opposed electrode	Greater than the outer diameter D_3 of the ring electrode			

In addition to the items listed in Table C.1, use of the following is implied, all of which need calibrating in accordance with ISO 18899:

- a timer;
- a thermometer for monitoring the conditioning and test temperatures;
- a hygrometer for monitoring the conditioning and test humidity;
- instruments for determining the dimensions of the test pieces and the electrodes.

Bibliography

- [1] ISO 1853, *Conducting and dissipative rubbers, vulcanized or thermoplastic — Measurement of resistivity*
- [2] IEC 60093:1980, *Methods of test for volume resistivity and surface resistivity of solid electrical insulating materials*

ICS 83.060

Price based on 14 pages