

INTERNATIONAL STANDARD

ISO 14275

First edition
2002-06-15

Aerospace — Drives, internal, offset cruciform, ribbed — Metric series

*Aéronautique et espace — Empreintes cruciformes déportées, avec saillies
antidérapantes — Série métrique*



Reference number
ISO 14275:2002(E)

© ISO 2002

PDF disclaimer

This PDF file may contain embedded typefaces. In accordance with Adobe's licensing policy, this file may be printed or viewed but shall not be edited unless the typefaces which are embedded are licensed to and installed on the computer performing the editing. In downloading this file, parties accept therein the responsibility of not infringing Adobe's licensing policy. The ISO Central Secretariat accepts no liability in this area.

Adobe is a trademark of Adobe Systems Incorporated.

Details of the software products used to create this PDF file can be found in the General Info relative to the file; the PDF-creation parameters were optimized for printing. Every care has been taken to ensure that the file is suitable for use by ISO member bodies. In the unlikely event that a problem relating to it is found, please inform the Central Secretariat at the address given below.

© ISO 2002

All rights reserved. Unless otherwise specified, no part of this publication may be reproduced or utilized in any form or by any means, electronic or mechanical, including photocopying and microfilm, without permission in writing from either ISO at the address below or ISO's member body in the country of the requester.

ISO copyright office
Case postale 56 • CH-1211 Geneva 20
Tel. + 41 22 749 01 11
Fax + 41 22 749 09 47
E-mail copyright@iso.ch
Web www.iso.ch

Printed in Switzerland

Foreword

ISO (the International Organization for Standardization) is a worldwide federation of national standards bodies (ISO member bodies). The work of preparing International Standards is normally carried out through ISO technical committees. Each member body interested in a subject for which a technical committee has been established has the right to be represented on that committee. International organizations, governmental and non-governmental, in liaison with ISO, also take part in the work. ISO collaborates closely with the International Electrotechnical Commission (IEC) on all matters of electrotechnical standardization.

International Standards are drafted in accordance with the rules given in the ISO/IEC Directives, Part 3.

The main task of technical committees is to prepare International Standards. Draft International Standards adopted by the technical committees are circulated to the member bodies for voting. Publication as an International Standard requires approval by at least 75 % of the member bodies casting a vote.

ISO 14275 was prepared by Technical Committee ISO/TC 20, *Aircraft and space vehicles*, Subcommittee SC 4, *Aerospace fastener systems*.

.....

Introduction

The International Organization for Standardization (ISO) draws attention to the fact that it is claimed that compliance with this International Standard may involve the use of a patent concerning internal ribbed drives specified in this International Standard.

Patent rights are held by the Phillips Screw Company worldwide. These internal drives are also produced and marketed under the designation of ACR[®] Torq-Set[®].

ISO takes no position concerning the evidence, validity and scope of this patent right.

The holder of this patent right has assured the ISO that he is willing to negotiate licences under reasonable and non-discriminatory terms and conditions with applicants throughout the world. In this respect, the statement of the holder of this patent right is registered with the ISO. Information may be obtained from:

Phillips Screw Company
508 Edgewater Drive
Wakefield, MA 01880
USA

Attention is drawn to the possibility that some of the elements of this International Standard may be the subject of patent rights other than those identified above. ISO shall not be held responsible for identifying any or all such patent rights.

.....

Aerospace — Drives, internal, offset cruciform, ribbed — Metric series

1 Scope

This International Standard specifies the dimensions of metric internal, offset cruciform, ribbed drives used in metric screws in the nominal thread diameter range of 3 mm to 20 mm.

Drivers and gauges used in conjunction with these drives are defined in ISO 14277 and ISO 14278.

2 Normative references

The following normative documents contain provisions which, through reference in this text, constitute provisions of this International Standard. For dated references, subsequent amendments to, or revisions of, any of these publications do not apply. However, parties to agreements based on this International Standard are encouraged to investigate the possibility of applying the most recent editions of the normative documents indicated below. For undated references, the latest edition of the normative document referred to applies. Members of ISO and IEC maintain registers of currently valid International Standards.

ISO 3202:1997, *Aerospace — Screws, pan head, internal offset cruciform ribbed or unribbed drive, threaded to head, MJ threads, metallic material, coated or uncoated, strength classes less than or equal to 1 100 MPa — Dimensions*

ISO 5856:1991, *Aerospace — Screws, 100° normal countersunk head, internal offset cruciform ribbed drive, normal shank, short or medium length MJ threads, metallic material, coated or uncoated, strength classes less than or equal to 1 100 MPa — Dimensions*

ISO 7913:1994, *Aerospace — Bolts and screws, metric — Tolerances of form and position*

ISO 13921:1996, *Aerospace — Screws, 100° reduced countersunk head, internal offset cruciform ribbed or unribbed drive, normal shank, short or medium length MJ threads, metallic material, coated or uncoated, strength classes less than or equal to 1 100 MPa — Dimensions*

3 Configuration and dimensions

See Figures 1, 2 and 3 and Tables 1, 2 and 3.

Dimensions and tolerances are expressed in millimetres.

The presentation of the location tolerances conforms to ISO 1101.

4 Designation

The drive designation shall be as follows:

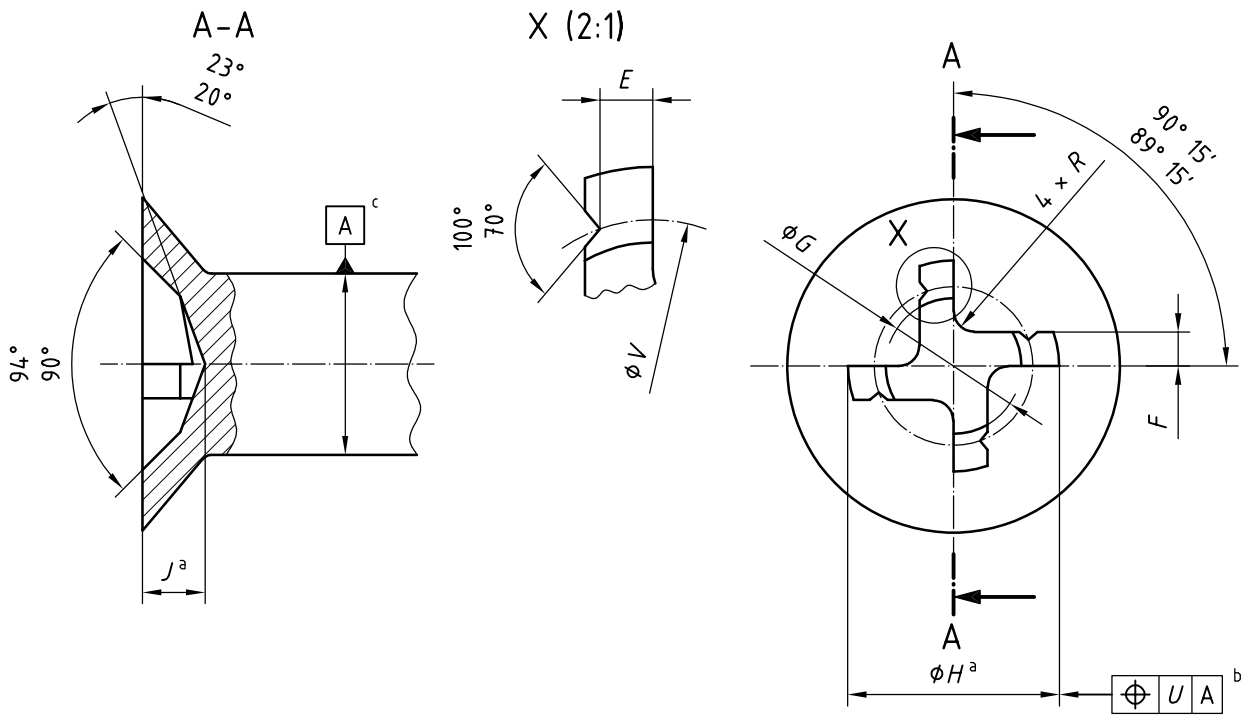
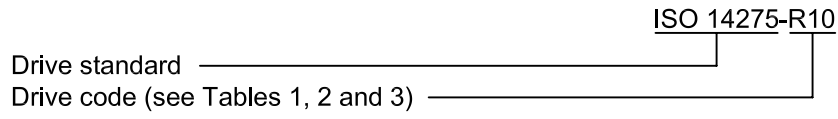

- a Values of parameters for specified heads are listed in Tables 2 and 3.
- b This location tolerance applies to all head configurations.
- c As defined in ISO 7913.

Figure 1 — Configuration — Drive

Table 1 — Dimensions — Drive

Drive code	<i>E</i>		<i>F</i>		<i>G</i>		<i>R</i>		<i>U</i>	<i>V^a</i>		Drive code inches ^b
	max.	min.	max.	min.	max.	min.	max.	min.		max.	min.	
R3	0,495	0,470	0,58	0,51	1,7	1,6	0,46	0,20	0,3	2,21	1,90	4
R3,5	0,648	0,622	0,74	0,66	2,08	1,98	0,76	0,41		2,69	2,39	6
R4	0,775	0,749	0,86	0,79	2,44	2,34				3,18	2,87	8
R5	0,902	0,876	0,99	0,91	2,82	2,72	1,02	0,58		3,66	3,35	10
R6	1,206	1,181	1,30	1,22	3,73	3,63			0,4	1,32	0,79	4,78
R8	1,537	1,511	1,62	1,55	4,67	4,57	6,20	5,89				5/16
R10	1,842	1,816	1,93	1,85	5,59	5,49	7,42	7,11				3/8
R12	1,476	2,451	2,59	2,49	7,42	7,32	2,26	1,57	0,6	9,86	9,55	1/2
R14	2,781	2,756	2,92	2,82	8,33	8,23	2,74	1,98		11,05	10,74	9/16
R16	3,086	3,061	3,22	3,12	9,27	9,17				12,27	11,96	5/8
R18	3,683	3,658	3,86	3,76	11,1	11,0			14,71	14,40	3/4	

^a The ribs shall be at least on the lower 75 % of the wall.

^b For information and comparison purposes only.

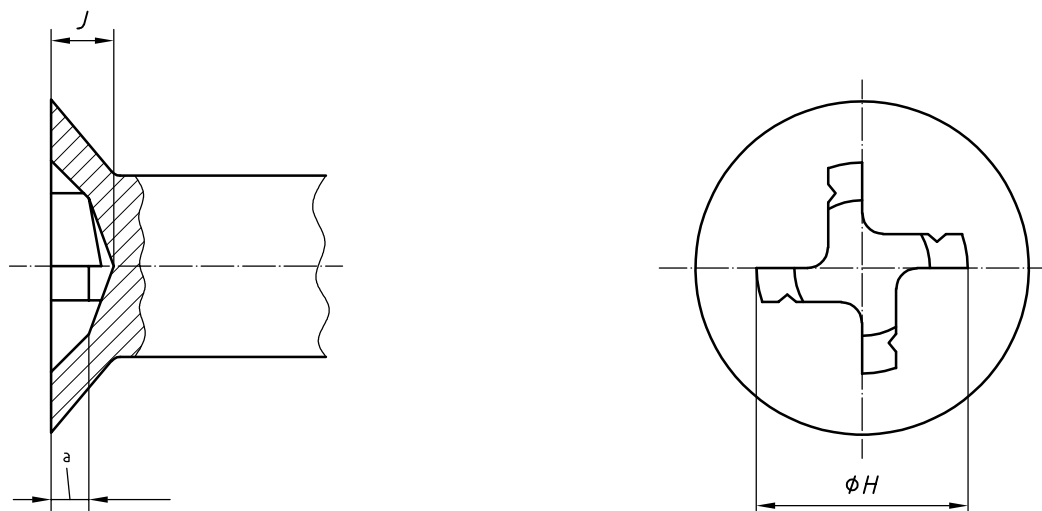

a Gauge penetration

Figure 2 — Configuration — Drive in normal and reduced 100° countersunk head

Table 2 — Dimensions — Drive in normal and reduced 100° countersunk head

Screw normal shank or thread diameter	Drive code		Drive code	H		J		Gauge penetration	
	100° countersunk head			max.	min.	max.	min.	max.	min.
	normal ^a	reduced ^b							
3	R3	—	R3	3,76	3,51	1,40	1,14	1,029	0,775
3,5	R3,5	—	R3,5	4,62	4,37	1,68	1,42	1,270	1,003
4	R4	R3	R4	5,46	5,21	1,98	1,73	1,511	1,219
5	R5	R4	R5	6,30	6,05	2,29	2,03	1,740	1,422
6	R6	R5	R6	8,26	8,00	3,00	2,74	2,261	1,905
7			R8	9,07	8,81	3,10	2,84	2,184	1,778
8	R8	R6	R8	10,85	10,59	3,68	3,43	2,616	2,159
10	R10	R8	R10	14,43	14,17	4,90	4,65	3,493	2,934
12	R12	R10	R12	16,21	15,95	5,51	5,26	3,924	3,315
14	R14	R12	R14	17,98	17,73	6,12	5,87	4,343	3,683
16	R16	R14	R16	21,56	21,31	7,32	7,06	5,232	4,470
18	R18	R16	R18						
20									

^a Head as defined in ISO 5856.
^b Head as defined in ISO 13921.

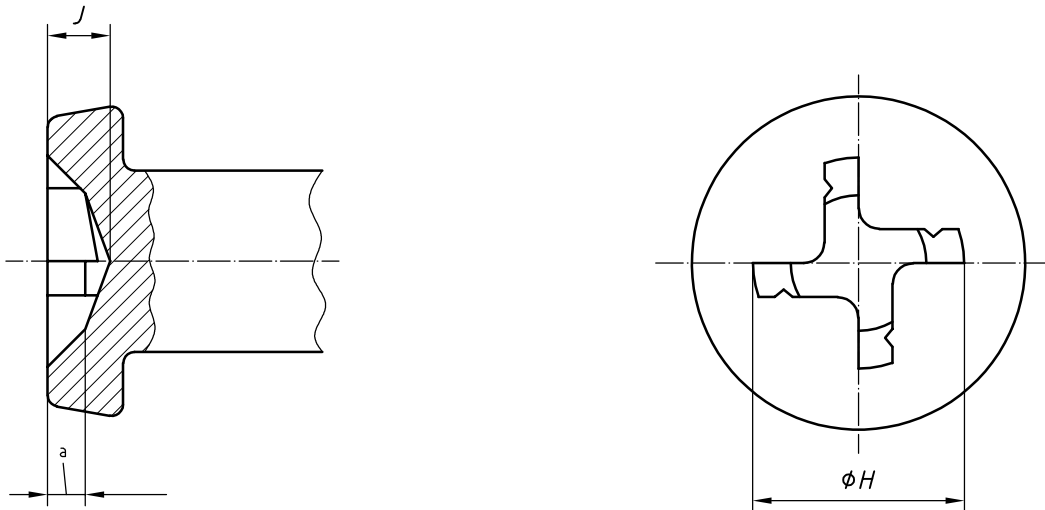

a Gauge penetration

Figure 3 — Configuration — Drive in pan head

Table 3 — Dimensions — Drive in pan head

Screw normal shank or thread diameter ^a	Drive code	H		J		Gauge penetration	
		max.	min.	max.	min.	max.	min.
3	R3	3,99	3,73	1,50	1,24	1,143	0,889
3,5	R3,5	4,90	4,65	1,83	1,57	1,410	1,143
4	R4	5,79	5,54	2,16	1,90	1,676	1,384
5	R5	6,68	6,43	2,49	2,24	1,930	1,613
6	R6	8,76	8,51	3,25	3,00	2,515	2,159
7							
8	R8	9,70	9,45	3,40	3,15	2,502	2,096
10	R10	11,61	11,35	4,09	3,84	2,997	2,540
12	R12	14,43	14,17	4,90	4,65	3,492	2,934

^a Pan head as defined in ISO 3202.

Bibliography

- [1] ISO 1101:—¹, *Geometrical Product Specifications (GPS) — Geometrical tolerancing — Tolerances of form, orientation, location and run-out*
- [2] ISO 14277:2002 *Aerospace — Drivers, ribbed, for internal offset cruciform ribbed or unribbed drives — Metric series*
- [3] ISO 14278:2002, *Aerospace — Gauges, for internal offset cruciform ribbed or unribbed drives — Metric series*

1) To be published. (Revision of ISO 1101:1983)

ICS 49.030.20

Price based on 6 pages

© ISO 2002 – All rights reserved