

INTERNATIONAL STANDARD

ISO 14230-1

First edition
1999-03-15

Road vehicles — Diagnostic systems — Keyword Protocol 2000 —

Part 1: Physical layer

*Véhicules routiers — Systèmes de diagnostic — Protocole «Keyword
2000» —*

Partie 1: Couche physique



Reference number
ISO 14230-1:1999(E)

Contents

1 Scope..... 1

2 Normative references..... 1

3 Definitions..... 1

4 Allowed configurations..... 2

5 Signal and communication specifications 2

5.1 Signal..... 2

5.2 Communication specification 3

6 Requirements of diagnostic tester 4

6.1 Minimum functional requirements 4

6.2 Electrical specifications 4

7 Requirements of ECU 5

7.1 Input and output lines..... 5

7.2 Electrical specifications 5

7.3 Minimum functional capabilities..... 6

8 Requirements of wiring 6

Annex A (informative) Bibliography..... 7

© ISO 1999

All rights reserved. Unless otherwise specified, no part of this publication may be reproduced or utilized in any form or by any means, electronic or mechanical, including photocopying and microfilm, without permission in writing from the publisher.

International Organization for Standardization
Case postale 56 • CH-1211 Genève 20 • Switzerland
Internet iso@iso.ch
Printed in Switzerland

Foreword

ISO (the International Organization for Standardization) is a worldwide federation of national standards bodies (ISO member bodies). The work of preparing International Standards is normally carried out through ISO technical committees. Each member body interested in a subject for which a technical committee has been established has the right to be represented on that committee. International organizations, governmental and non-governmental, in liaison with ISO, also take part in the work. ISO collaborates closely with the International Electrotechnical Commission (IEC) on all matters of electrotechnical standardization.

Draft International Standards adopted by the technical committees are circulated to the member bodies for voting. Publication as an International Standard requires approval by at least 75 % of the member bodies casting a vote.

International Standard ISO 14230-1 was prepared by Technical Committee ISO/TC 22, *Road vehicles*, Subcommittee SC 3, *Electrical and electronic equipment*.

ISO 14230 consists of the following parts, under the general title *Road vehicles — Diagnostic systems — Keyword protocol 2000* :

- *Part 1: Physical layer*
- *Part 2: Data link layer*
- *Part 3: Application layer*
- *Part 4: Requirements for emissions-related systems*

Annex A of this part of ISO 14230 is given for information only.

Road vehicles — Diagnostic systems — Keyword protocol 2000 —

Part 1: Physical layer

1 Scope

This part of ISO 14230 describes the physical layer, based on ISO 9141, on which the diagnostic services will be implemented. It is based on the physical layer described in ISO 9141-2, but expanded to allow for road vehicles with either 12 V or 24 V voltage supply.

NOTE — In this part of ISO 14230, values given in parentheses apply to 24 V systems.

2 Normative references

The following standards contain provisions which, through reference in this text, constitute provisions of this part of ISO 14230. At the time of publication, the editions indicated were valid. All standards are subject to revision, and parties to agreement based on this part of ISO 14230 are encouraged to investigate the possibility of applying the most recent editions of the standards indicated below. Members of IEC and ISO maintain registers of currently valid International Standards.

ISO 7637-1:1990, *Road vehicles — Electrical disturbance by conduction and coupling — Part 1: Passenger cars and light commercial vehicles with nominal 12 V supply voltage — Electrical transient conduction along supply lines only.*

ISO 7637-2:1990, *Road vehicles — Electrical disturbance by conduction and coupling — Part 2: Commercial vehicles with nominal 24 V supply voltage — Electrical transient conduction along supply lines only.*

ISO 9141:1989, *Road vehicles — Diagnostic systems — Requirements for interchange of digital information.*

ISO 14230-2:1998, *Road vehicles — Diagnostic systems — Keyword protocol 2000 — Part 2: Data link layer.*

ISO 14230-3:1998, *Road vehicles — Diagnostic systems — Keyword protocol 2000 — Part 3: Application layer.*

ISO 15031-3:—¹⁾, *Road vehicles — Communication between vehicle and external equipment for emissions-related diagnostics — Part 3: Diagnostic connector and related electrical circuit: specification and use.*

3 Definitions

For the purposes of this part of ISO 14230, the definitions in ISO 9141 and the following definitions apply.

3.1 rise time

(transmitters) time taken for the voltage to change from $20V_B/100$ to $80V_B/100$, where V_B is the vehicle battery voltage

3.2 fall time

(transmitters) time taken for the voltage to change from $80V_B/100$ to $20V_B/100$, where V_B is the vehicle battery voltage

1) To be published.

4 Allowed configurations

4.1 Vehicle ECUs which support the protocol described in ISO 14230 shall support either a one-wire (K line only) or a two-wire (K and L) communication connection for diagnosis, test or maintenance. Vehicle battery voltage, V_B , power ground and signal ground shall be provided by the ECU(s), or the vehicle to the tester.

Line K is a bidirectional line. It is used during initialization to convey address information or, in the case of fast initialization, the wake-up pattern from the diagnostic tester to vehicle ECUs, simultaneously with the L line. After conveying this information, the K line is used for all other diagnostic communications between tester and vehicle ECUs, in both directions. This includes the completion of the initialization sequence and all other communication services as described in ISO 14230-2 and the subsequent communication as described in ISO 14230-2 and ISO 14230-3.

Line L is a unidirectional line and is only used during initialization to convey address information or, in the case of fast initialization, the wake-up pattern from the diagnostic testers to vehicle ECUs, simultaneously with the K line. At all other times, it should idle in the logic "1" state.

Figure 1 shows the system configurations allowed, indicating the role of each of the lines K and L.

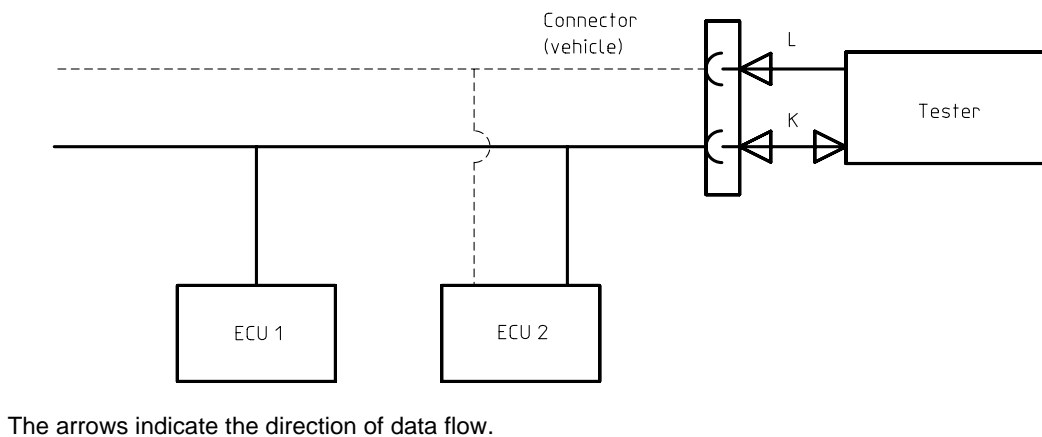

Figure 1 — Possible system configurations

4.2 If any ECU, either of one type or in combination, are linked on a bus, the system designer shall ensure that the configuration is capable of correct operation. For example, data from one ECU shall not initialize the serial communication of another ECU on the bus and an initialization signal shall not cause more than one ECU to respond simultaneously; it may, however, initialize a number of ECUs on the bus which then respond in an orderly sequential manner.

If lines K and L are used for purposes other than inspection, test and diagnosis, care shall be taken to avoid data collision and incorrect operation in all modes.

5 Signal and communication specifications

NOTE — On those vehicles fitted with ISO 15031-3 connectors, all measurements should be referenced to the signal ground and battery supply pins of that connector. On other vehicles without ground and supply pins, the battery posts should be used as reference.

5.1 Signal

For proper operation of the serial communication, both ECU and diagnostic tester shall correctly determine each logic state as follows:

- a logic "0" is equivalent to a voltage level on the line of less than $20 V_B/100$ for transmitter, and $30 V_B/100$ for receiver;

— a logic "1" is equivalent to a voltage level on the line of greater than $80 V_B/100$ for transmitter, and $70 V_B/100$ for receiver.

In addition, the slope times shall be less than 10 % (15 %) of the bit time.

Voltage levels between $30 V_B/100$ and $70 V_B/100$ may be detected as either logic "0" or logic "1".

NRZ coding shall be used. The bit time is defined as half the time between the $50 V_B/100$ levels of successive rising or falling edges of alternating "1" and "0" bits.

Figure 2 illustrates the worst case on signal levels. For electrical specifications of diagnostic testers, see 6.2; for ECUs, see 7.2

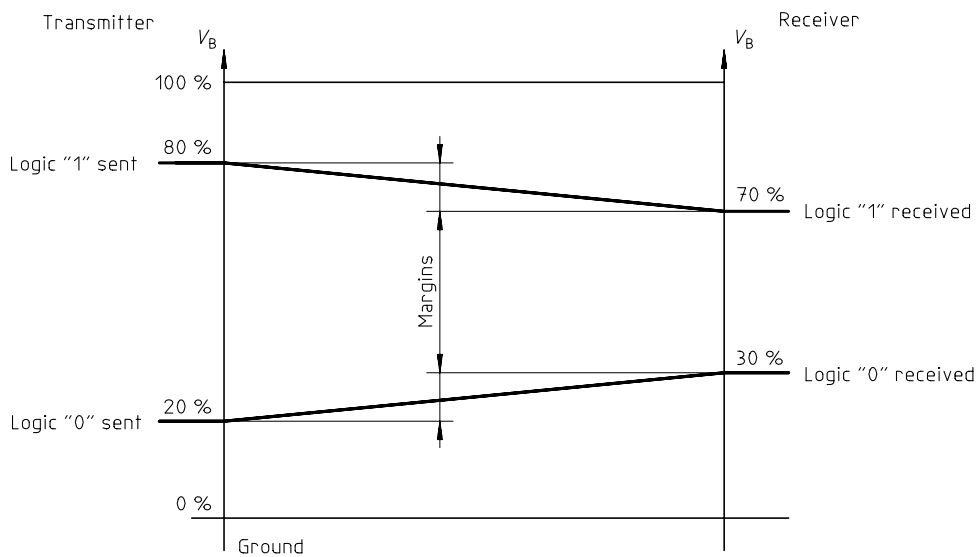

Figure 2 — Signal voltage levels, worst case values

5.2 Communication specification

5.2.1 The configuration is shown schematically in figure 3.

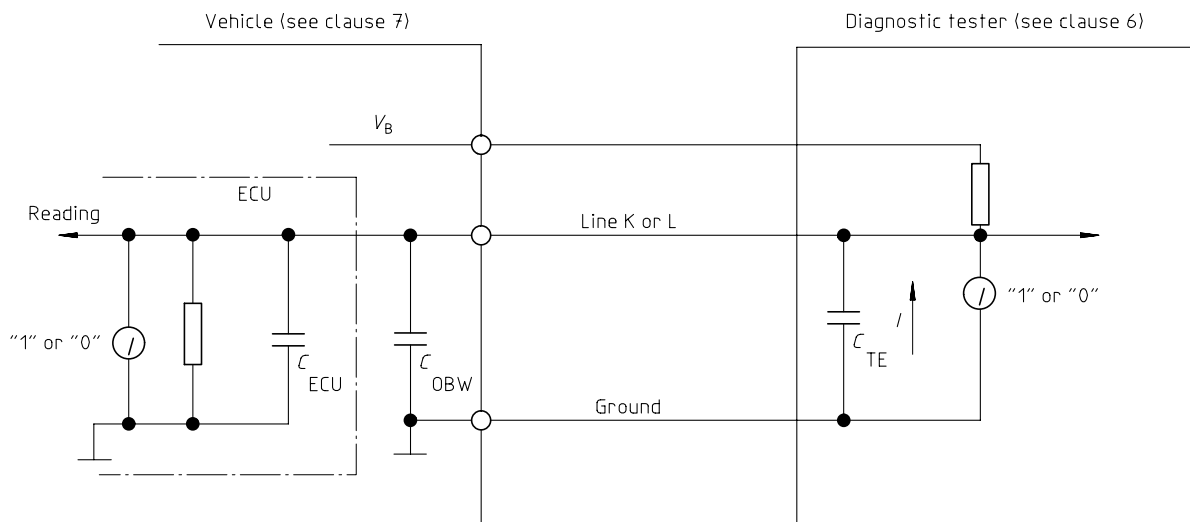

Figure 3 — Communication schematic

5.2.2 The capacitance contribution of the diagnostic tester and associated cables are termed C_{TE} . The capacitance contribution of the on-board wiring is termed C_{OBW} . The sum of the input capacitance of all the ECUs on the bus is defined thus:

$$C_{ECU} = \sum_{i=1}^n C_{ECU_i}$$

where n is the number of ECUs on the bus.

Values for C_{ECU} , C_{OBW} and C_{TE} shall be selected such that

- for vehicles with 12V nominal supply: $C_{ECU} + C_{OBW} \leq 7,2 \text{ nF}$ and $C_{TE} \leq 2 \text{ nF}$
- for vehicles with 24V nominal supply: $C_{ECU} + C_{OBW} \leq 5 \text{ nF}$ and $C_{TE} \leq 2 \text{ nF}$.

These values are derived from the circuit resistance and baud rate tolerances (see clauses 6 and 7), allowed slope times and switching thresholds (see 5.1) and assuming a maximum communication speed of 10,4 kBd. If a higher or lower maximum communication speed is chosen then the designer will reduce or increase the allowed capacitance accordingly. The formula to be used is given in ISO 9141.

6 Requirements of diagnostic tester

6.1 Minimum functional requirements

The diagnostic tester shall be capable of supporting the initialization methods and the communication protocol described in ISO 14230-2.

6.2 Electrical specifications

6.2.1 The specifications in 6.2.2 to 6.2.7 shall apply over a working temperature range of 0 °C to 50 °C. They apply to nominal 12 V (24 V) systems for which the diagnostic tester shall operate correctly in the range 8 V to 16 V (16 V to 32 V) of the vehicle battery voltage V_B .

Manufacturers of diagnostic testers are encouraged to extend these limits of correct operation for vehicle battery voltage V_B and working temperature.

6.2.2 For lines K and L of the diagnostic tester not connected to an ECU, each line shall be internally pulled up to V_B via a nominal 510 Ω (1 k Ω) resistor.

When the diagnostic tester is linked to an ECU, it shall meet the following requirements:

a) Transmission state

- At logic "1" the diagnostic tester shall have an equivalent voltage source greater than $90 V_B/100$, sourced from the vehicle battery supply, V_B , and an equivalent resistance of $510 \Omega \times (1 \pm 5 \%)$ [$1 \text{ k}\Omega \times (1 \pm 5 \%)$].
- At logic "0" the diagnostic tester shall have an equivalent voltage of less than $10 V_B/100$, at a maximum sink current of 100 mA.

b) Receiving state

- The equivalent resistance on the line K of the diagnostic tester shall be $510 \Omega \times (1 \pm 5 \%)$ [$1 \text{ k}\Omega \times (1 \pm 5 \%)$].

6.2.3 The diagnostic tester shall maintain fast initialization and communication baud rates to $\pm 0,5\%$ of nominal values where specified by the protocol. Where determined by measurement the baud rate shall be maintained to $\pm 1\%$. The 5 baud address shall be transmitted with a tolerance of $\pm 0,5\%$.

6.2.4 For each byte the diagnostic tester shall be capable of determining the status of any bit, the transitions of which are shifted by not more than 30 % of the bit time relative to their calculated position in time.

6.2.5 The diagnostic tester shall not transfer to the open lines K and L any voltage higher than V_B or 40 V, whichever is the lower, or any voltage which is lower than $-1V$. This includes suppression of voltage excursions of V_B as detailed in ISO 7637-1 for 12 V electrical systems and in ISO 7637-2 for 24 V systems.

6.2.6 The total capacitance of the diagnostic tester and its cable and connector shall not exceed 2 nF.

7 Requirements of ECU

The combined impedances defined in 6.2.6 are the primary constraints. For guidance only the average values per ECU on a system with ten ECUs connected is given. This value may change if a different number of ECUs are connected.

No capacitance value per ECU is given for 24 V systems, but the total vehicle capacitance shall conform to the limits given in clause 5.

7.1 Input and output lines

ECUs shall have one (K) or two (K and L) connections as defined in 4.1. V_B and ground shall also be made available to the tester but need not come directly from the ECU.

7.2 Electrical specifications

7.2.1 Line K

At logic "1", or in the receiving state, the ECU shall behave like a resistance to ground of at least 50 k Ω (100 k Ω).

If an internal resistance is used between line K and V_B , the value shall not be less than 100 k Ω (200 k Ω).

The capacitance of line K with respect to ground of each ECU should not exceed 500 pF.

In case of problems (e.g. with EMI) the vehicle manufacturer's system designer may use a different specification, but attention shall be paid to the maximum value of the capacitance of the vehicle which is given by the summation of C_{OBW} and C_{ECU} . This value shall not exceed the limits specified in 5.2.2.

At logic "0" the ECU shall have an equivalent sink resistance not more than 110 Ω (220 Ω) between line K and ground. In addition the sink resistance shall be designed so the slope time of the falling edge is as in 5.1.

When the serial communication of the ECU is not in operation and the diagnostic tester is connected, the output of the ECU shall be at a logic "1".

7.2.2 Line L

The input resistance to ground shall be at least 50 k Ω (100 k Ω).

If an internal resistance is used between line L and V_B , the value shall not be less than 100 k Ω (200 k Ω).

The capacitance of line L with respect to ground of each ECU should not exceed 500 pF.

7.2.3 Lines K and L

The input/output circuitry of the ECUs shall withstand transitions and over voltage present on the diagnostic tester lines K and L via the diagnostic tester source resistance, limited as below.

- a) K and L shall withstand
- 20 V dc permanent (36 V dc permanent);
 - 24 V dc for 30 min (42 V dc for 30 min);
 - 30 V dc for 1 min (48 V dc for 1 min).
- b) K and L shall also withstand pulses 3a and 3b according to ISO 7637-1 for 12 V electrical systems and to ISO 7637-2 for 24 V electrical systems, where the maximum positive voltage shall be an absolute value of 40 V (60 V), and the worst case negative voltage will be -1 V relative to ground.

7.3 Minimum functional capabilities

The ECU shall be capable of supporting the communication protocol and at least one of the initialization methods described in ISO 14230-2. It shall be capable of ignoring the initialization of other ECUs on the bus if they respond to different methods of initialization to its own.

The ECU shall transmit messages with bit rates within $\pm 1,7\%$ ($\pm 1\%$) of nominal rate when a baud rate is specified by the protocol.

8 Requirements of wiring

The capacitance of each serial communication line built into the vehicle shall not exceed 2 nF with respect to vehicle signal ground, when measured without any ECU connected.

V_B and ground shall be made available to the diagnostic tester but need not come directly from an ECU.

Annex A (informative)

Bibliography

- [1] ISO 9141-2: 1994, *Road vehicles — Diagnostic systems — Part 2: CARB requirements for interchange of digital information*.
- [2] SAE J 1962, *Diagnostic connector*. January 1995.

ICS 43.180

Descriptors: road vehicles, motor vehicles, electronic equipment, electronic control units, diagnostic systems, digital technics, information interchange, protocols, physical layer.

Price based on 7 pages
