**Road vehicles — Unified diagnostic
services (UDS) —**

Part 7:
**UDS on local interconnect network
(UDSonLIN)**

*Véhicules routiers — Services de diagnostic unifiés (SDU) —
Partie 7: SDU sur l'implémentation LIN (SDU sur LIN)*





COPYRIGHT PROTECTED DOCUMENT

© ISO 2015

All rights reserved. Unless otherwise specified, no part of this publication may be reproduced or utilized otherwise in any form or by any means, electronic or mechanical, including photocopying, or posting on the internet or an intranet, without prior written permission. Permission can be requested from either ISO at the address below or ISO's member body in the country of the requester.

ISO copyright office
Case postale 56 • CH-1211 Geneva 20
Tel. + 41 22 749 01 11
Fax + 41 22 749 09 47
E-mail copyright@iso.org
Web www.iso.org

Published in Switzerland

Contents

	Page
Foreword	v
Introduction	vi
1 Scope	1
2 Normative references	1
3 Terms, definitions, symbols, and abbreviated terms	2
3.1 Terms and definitions.....	2
3.2 Symbols and abbreviated terms.....	2
4 Conventions	2
5 Document overview	2
6 UDSONLIN implementation requirements	4
6.1 General.....	4
6.2 Definition of diagnostic classes.....	4
6.2.1 Overview.....	4
6.2.2 Diagnostic class I.....	4
6.2.3 Diagnostic class II.....	4
6.2.4 Diagnostic class III.....	4
6.3 LIN node requirements.....	5
6.3.1 Master node requirements.....	5
6.3.2 Slave node requirements.....	5
6.4 Signal-based diagnostics.....	5
6.4.1 Slave implementation.....	5
6.4.2 Master implementation.....	6
6.5 Tool suite support.....	6
7 Unified diagnostic services implementation on LIN	6
7.1 UDSONLIN services overview.....	6
7.2 Diagnostic and communication control functional unit.....	7
7.2.1 CommunicationControl (0x28) service.....	7
7.2.2 ResponseOnEvent (0x86) service.....	8
8 Application layer requirements	8
8.1 Application layer services.....	8
8.2 Application layer protocol.....	8
8.3 Application layer timing.....	8
8.3.1 General.....	8
8.3.2 Application layer timing parameter values.....	9
9 Presentation layer requirements	11
10 Session layer requirements	11
11 Transport/network layer interface adaptation	11
11.1 General information.....	11
11.2 LIN transport/network layer interface adaptation.....	11
11.2.1 Mapping of data link independent service primitives onto LIN data link dependent service primitives.....	11
11.2.2 Mapping of T_PDU onto N_PDU for message transmission.....	11
12 Network layer diagnostic implementation requirements	12
12.1 LIN slave node network layer requirements.....	12
12.2 LIN master node network layer requirements.....	13
12.2.1 Network address requirements.....	13
12.2.2 Use of functional addressing.....	13
13 Data link layer diagnostic implementation requirements	13

Bibliography **14**

Foreword

ISO (the International Organization for Standardization) is a worldwide federation of national standards bodies (ISO member bodies). The work of preparing International Standards is normally carried out through ISO technical committees. Each member body interested in a subject for which a technical committee has been established has the right to be represented on that committee. International organizations, governmental and non-governmental, in liaison with ISO, also take part in the work. ISO collaborates closely with the International Electrotechnical Commission (IEC) on all matters of electrotechnical standardization.

The procedures used to develop this document and those intended for its further maintenance are described in the ISO/IEC Directives, Part 1. In particular the different approval criteria needed for the different types of ISO documents should be noted. This document was drafted in accordance with the editorial rules of the ISO/IEC Directives, Part 2 (see www.iso.org/directives).

Attention is drawn to the possibility that some of the elements of this document may be the subject of patent rights. ISO shall not be held responsible for identifying any or all such patent rights. Details of any patent rights identified during the development of the document will be in the Introduction and/or on the ISO list of patent declarations received (see www.iso.org/patents).

Any trade name used in this document is information given for the convenience of users and does not constitute an endorsement.

For an explanation on the meaning of ISO specific terms and expressions related to conformity assessment, as well as information about ISO's adherence to the WTO principles in the Technical Barriers to Trade (TBT) see the following URL: [Foreword - Supplementary information](#)

The committee responsible for this document is ISO/TC 22, *Road vehicles*, Subcommittee SC 3, *Electrical and electronic equipment*.

ISO 14229 consists of the following parts, under the general title *Road vehicles — Unified diagnostic services (UDS)*:

- *Part 1: Specification and requirements*
- *Part 2: Session layer services*
- *Part 3: Unified diagnostic services on CAN implementation (UDSonCAN)*
- *Part 4: Unified diagnostic services on FlexRay implementation (UDSonFR)*
- *Part 5: Unified diagnostic services on Internet Protocol implementation (UDSonIP)*
- *Part 6: Unified diagnostic services on K-Line implementation (UDSonK-Line)*
- *Part 7: Unified diagnostic services on Local Interconnect Network implementation (UDSonLIN)*

Introduction

This part of ISO 14229 has been established in order to enable the implementation of unified diagnostic services, as specified in ISO 14229-1, on UART-based local interconnect networks (UDSonLIN).

To achieve this, it is based on the Open Systems Interconnection (OSI) Basic Reference Model specified in ISO/IEC 7498-1 and ISO/IEC 10731, which structures communication systems into seven layers. When mapped on this model, the services specified by ISO 14229 are divided into the following.

- Application layer (layer 7), unified diagnostic services specified in ISO 14229-1, ISO 14229-3 UDSonCAN, ISO 14229-4 UDSonFR, ISO 14229-5 UDSonIP, ISO 14229-6 UDSonK-Line, ISO 14229-7 UDSonLIN, further standards, and ISO 27145-3 WWH-OBD.
- Presentation layer (layer 6), vehicle manufacturer specific, ISO°27145-2 WWH-OBD.
- Session layer services (layer 5) specified in ISO 14229-2.
- Transport layer services (layer 4), specified in ISO 15765-2 DoCAN, ISO 10681-2 Communication on FlexRay, ISO 13400-2 DoIP, ISO 17987-2 LIN, ISO 27145-4 WWH-OBD.
- Network layer services (layer 3), specified in ISO 15765-2 DoCAN, ISO 10681-2 Communication on FlexRay, ISO 13400-2 DoIP, ISO 17987-2 LIN, ISO 27145-4 WWH-OBD.
- Data link layer (layer 2), specified in ISO 11898-1, ISO 11898-2, ISO 17458-2, ISO 13400-3, IEEE 802.3, ISO 14230-2, ISO 17987-3 LIN and further standards, ISO 27145-4 WWH-OBD.
- Physical layer (layer 1), specified in ISO 11898-1, ISO 11898-2, ISO 17458-4, ISO 13400-3, IEEE 802.3, ISO 14230-1, ISO 17987-4 LIN and further standards, ISO 27145-4 WWH-OBD.

These services should be in accordance with [Table 1](#).

Table 1 — LIN enhanced diagnostics, legislated OBD and WWH-OBD specification reference applicable to the OSI layers

Applicability	OSI seven layer	Enhanced diagnostics services						WWH-OBD
Seven layer according to ISO/IEC 7498-1 and ISO/IEC 10731	Application (layer 7)	ISO 14229-1, ISO 14229-3 UDSonCAN, ISO 14229-4 UDSonFR, ISO 14229-5 UDSonIP, ISO 14229-6 UDSonK-Line, ISO 14229-7 UDSonLIN, further standards						ISO 27145-3
	Presentation (layer 6)	Vehicle manufacturer specific						ISO 27145-2
	Session (layer 5)	ISO 14229-2						
	Transport (layer 4)	ISO 15765-2	ISO 10681-2	ISO 13400-2	Not applicable	ISO 17987-2	Further standards	ISO 27145-4
	Network (layer 3)						Further standards	
	Data link (layer 2)	ISO 11898-1, ISO 11898-2	ISO 17458-2	ISO 13400-3, IEEE 802.3	ISO 14230-2	ISO 17987-3	Further standards	
	Physical (layer 1)		ISO 17458-4		ISO 14230-1	ISO 17987-4	Further standards	

The titles of future parts will be drafted as follows:

- *Part n: Unified diagnostic services on ... implementation (UDSon...)*

Road vehicles — Unified diagnostic services (UDS) —

Part 7:

UDS on local interconnect network (UDSonLIN)

1 Scope

This part of ISO 14229 specifies the implementation of a common set of unified diagnostic services (UDS) on UART-based local interconnect networks in road vehicles. The UDSonLIN diagnostics defines methods to implement diagnostic data transfer between a client and the LIN slave nodes through the LIN master node.

LIN slave nodes support three different diagnostic classes as defined in ISO 17987.

UDSonLIN references ISO 14229-1 and ISO 14229-2 and specifies implementation requirements of the following:

- diagnostic services to be used for diagnostic communication over LIN,
- server memory programming for in-vehicle LIN servers with an external test equipment, and
- configuration of a LIN slave node as specified in ISO 17987.

NOTE UDSonLIN does not specify any requirement for the in-vehicle LIN bus architecture.

This part of ISO 14229 makes reference to information contained in the following:

- ISO 14229-1,
- ISO 14229-2, and
- ISO 17987 (all parts).

This part of ISO 14229 does not include any redundant information of the above mentioned documents. It focuses on the following:

- additional requirements specific to the implementation of UDSonLIN network, and
- specific restrictions in the implementation of UDSonLIN network.

2 Normative references

The following documents, in whole or in part, are normatively referenced in this document and are indispensable for its application. For dated references, only the edition cited applies. For undated references, the latest edition of the referenced document (including any amendments) applies.

ISO 14229-1, *Road vehicles — Unified diagnostic services (UDS) — Part 1: Specification and requirements*

ISO 14229-2, *Road vehicles — Unified diagnostic services (UDS) — Part 2: Session layer services*

ISO 17987-3, *Road vehicles — Local Interconnect Network (LIN) — Part 3: Protocol specification*

3 Terms, definitions, symbols, and abbreviated terms

3.1 Terms and definitions

For the purposes of this document, the terms and definitions given in ISO 14229-1, ISO 14229-2, and ISO 17987 (all parts) apply.

3.2 Symbols and abbreviated terms

AE	address extension
CF	consecutive frame
DA	destination address
FC	flow control
FF	first frame
ID	identifier
Mtype	message type
NAD	node address
NCF	node configuration file
P2	server response time
SA	source address
SF	single frame
SFID	sub-function identifier
ST _{min}	separation time
TA	target address
UART	universal asynchronous receiver transmitter

4 Conventions

This part of ISO 14229 is based on the conventions discussed in the OSI Service Conventions (ISO/IEC 10731) as they apply for diagnostic services.

5 Document overview

[Figure 1](#) illustrates the document references from ISO 14229-1, ISO 14229-2, and ISO 17987 (all parts). ISO 14229-7 uses only a subset of the diagnostic services defined in ISO 14229-1 (see [Table 3](#)).

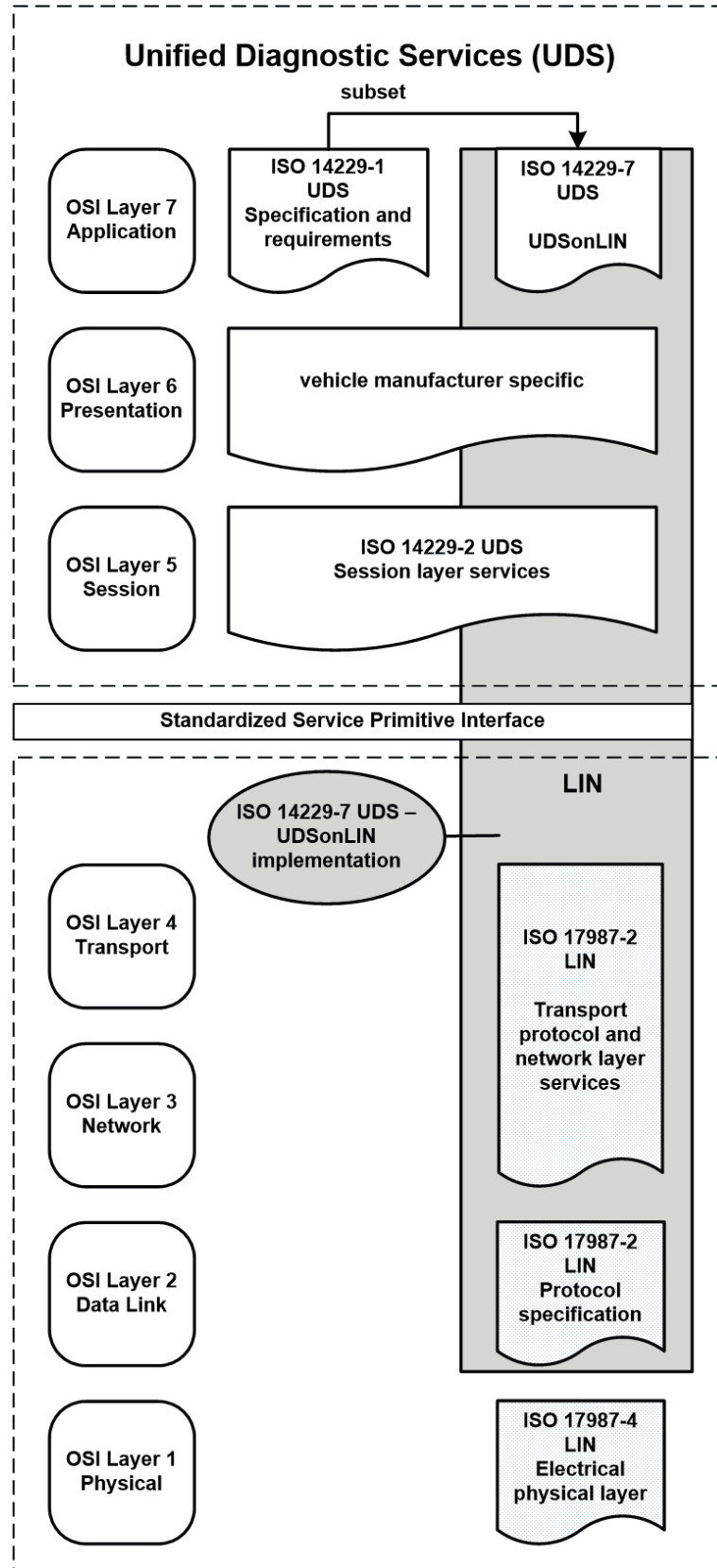

Figure 1 — UDSONLIN document reference according to OSI model

6 UDSONLIN implementation requirements

6.1 General

This clause defines how the diagnostic services, as defined in ISO 14229-1, apply to LIN.

To allow a common implementation of application layer and session layer for ISO 17987 and other communications, this part of ISO 14229 uses the session layer protocol as defined in ISO 14229-2 and focuses on necessary modifications and interfaces to adopt it to ISO 17987- series.

The subfunction parameter definitions take into account that the most significant bit is used for the `suppressPosRspMsgIndicationBit` parameter as defined in ISO 14229-1.

It is the vehicle manufacturer's responsibility to setup the LIN master and slave nodes to exchange UDSONLIN information according to ISO 17987- series.

6.2 Definition of diagnostic classes

6.2.1 Overview

Architectural, diagnostic communication performance, and transport protocol needs of slave nodes are accommodated by dividing diagnostic services functionality into three diagnostic classes.

Therefore, a diagnostic class is assigned to each slave node according to its level of diagnostic functionality and complexity.

6.2.2 Diagnostic class I

Smart and simple devices like intelligent sensors and actuators requiring none or very low amount of diagnostic functionality. Actuator control, sensor reading, and fault memory handling is done by the master node, using signal carrying frames. Therefore, specific diagnostic support for these tasks is not required. Fault indication is always signal-based.

6.2.3 Diagnostic class II

A diagnostic class II slave node is similar to a diagnostic class I slave node, but it provides node identification support. The extended node identification is normally required by vehicle manufacturers. Testers or master nodes use ISO 14229-1 diagnostic services to request the extended node identification information. Actuator control, sensor reading, and fault memory handling is done by the master node, using signal carrying frames. Therefore, specific diagnostic support for these tasks is not required. Fault indication is always signal-based.

6.2.4 Diagnostic class III

Diagnostic class III slave nodes are devices with enhanced application functions typically performing their own local information processing (e.g. function controllers, local sensor/actuator loops). The slave nodes execute tasks beyond the basic sensor/actuator functionality and, therefore, require extended diagnostic support. Direct actuator control and raw sensor data are often not exchanged with the master node and, therefore, not included in signal carrying frames. ISO 14229-1 diagnostic services for I/O control, sensor value reading, and parameter configuration (beyond node configuration) are required.

Diagnostic class III slave nodes have internal fault memory, along with associated reading and clearing services. Optionally, reprogramming (flash/NVRAM reprogramming) of the slave node is possible. This requires an implementation of a boot loader and necessary diagnostic services to unlock the device initiate downloads and transfer data, etc.

The primary difference between diagnostic class II and diagnostic class III is the distribution of diagnostic capabilities between the LIN master node and the LIN slave node for diagnostic class II while

for a diagnostic class III LIN slave node, no diagnostic application features of the LIN slave node are implemented in the LIN master node.

6.3 LIN node requirements

6.3.1 Master node requirements

6.3.1.1 Master message routing

The master node usually is a high performance ECU and, in most implementations, supports the ISO 14229-1 diagnostic services. The master node and the external test equipment are connected through a backbone bus (e.g. ISO 11898). The master node shall receive all diagnostic requests addressed to the slave nodes from the backbone bus and route them to the appropriate LIN cluster(s). Responses from the slave nodes shall be routed back to the backbone bus through the master node.

All diagnostic request and response messages addressed to the slave nodes can be routed in the network layer (i.e. no application layer routing). The master node shall implement the LIN transport protocol (see ISO 17987-2) as well as the transport protocols used on the backbone busses (e.g. ISO 15765-2).

6.3.1.2 Master node fault management, sensor reading, I/O control

Diagnostic class I and diagnostic class II slave nodes (see ISO 17987-3) provide signal-based fault information and sensor, I/O access through signal carrying frames. The LIN master node is responsible to handle the slave nodes signal based faults and handle the associated DTCs. The LIN master node serves UDS requests directly to the client/tester and acts as a diagnostic application layer gateway. UDS services provide access to the sensor/actuator signals on the LIN bus.

Diagnostic class III slave nodes (see ISO 17987-3) are independent diagnostic entities. The LIN master node does not implement diagnostic services for the diagnostic capabilities of its diagnostic class III slave nodes.

6.3.2 Slave node requirements

Slave nodes are typically electronic devices that are not involved in a complex data communication. Also, their need of distributing diagnostic data is low. However, most slave nodes shall transmit simple diagnostic information such as error indications in signal carrying frames.

Although diagnostics and node configuration services use the same frame IDs, i.e. 0x3C (master request frame) and 0x3D (slave response frame), different services are used for configuration and diagnostics. Node configuration can be performed by the master node independently while diagnostic services are always routed on request from external or internal test equipment. Both cases use the same node address (NAD) and transport protocol with the exception that configuration is always performed through SingleFrames (SF). Only slave nodes have an NAD. The NAD is also used as the source address in a diagnostic slave response frame.

NOTE There is a one-to-many mapping between a physical node and a logical node and it is addressed using the NAD.

6.4 Signal-based diagnostics

6.4.1 Slave implementation

Signal-based diagnostics are implemented by slave nodes (diagnostic class I and II), which do not implement a fault memory and the diagnostic protocol to directly access this fault memory from an external test tool.

There are two types of failure transmission through signal carrying frames.

- a) Type 1 failure information is periodically transmitted and encoded into an existing signal (e.g. upper values of signal range used to indicate specific failure conditions) by the slave node. A type 1 failure use case-specific and defined by vehicle manufacturers and is not part of this International Standard.
- b) Type 2 failure information is not periodically transmitted for components which do not generate a signal that is periodically transmitted (e.g. slave node internal failure). Additional signal-based failure transmission shall be implemented for type 2 failures (i.e. if a slave node is capable of locally detecting faults which are not transmitted through the associated signal in signal carrying frames already).

Each slave node shall transmit the failure status information that is monitored by the slave node to the master node through signal carrying frames. The status information shall contain the current failure status of the slave nodes' components. The signal shall support the states as defined in [Table 2](#).

Table 2 — Signal-based fault states

Description
no test result available, default, initialization value
test result: failed
test result: passed

If a slave node implements more than one independent function, a status signal can be assigned to each function. In this case, only the failing function could be disabled by the application.

The fault state signals are set in the status management of the LIN Description File (LDF).

6.4.2 Master implementation

A failure status signal shall be assigned for each failure that would result in a separate DTC in the master node.

This information is used to indicate a failure of one of the components to the master node's application, which can then store the associated DTC. There should be one signal per replaceable component to simplify repair and maintenance of the vehicle.

6.5 Tool suite support

The implementation of diagnostic services in LIN nodes, using the transport protocol and network layer services as defined in ISO 17987-2, may be supported by a tool suite, which is compatible with the requirements stated in ISO 17987-2, ISO 17987-3, and ISO 17987-5.

A standardized API with support of the 'C' programming language is specified in ISO 17987-5.

7 Unified diagnostic services implementation on LIN

7.1 UDSONLIN services overview

The purpose of [Table 3](#) is to reference all unified diagnostic services as they are applicable for an implementation of UDSONLIN. The table contains the sum of all applicable services. Certain applications using this part of ISO 14229 to implement UDSONLIN may restrict the number of useable services and may categorize them in certain application areas/diagnostic sessions (default session, programming session, etc.). The restriction of data length for all diagnostic services due to the data link layer applies (see [8.1](#)).

NOTE ISO 17987 series supports different diagnostic classes for LIN slave nodes. It is the vehicle manufacturer's responsibility to specify which diagnostic services of ISO 14229-1 are implemented in an LIN slave node.

Table 3 — Overview of applicable ISO^o14229-1 Unified diagnostic services and data ranges

Diagnostic service name (see ISO 14229-1)	Comment	Reference in this International Standard
Diagnostic and communication management functional unit		
DiagnosticSessionControl	No LIN-specific requirements	—
ECUReset	No LIN-specific requirements	—
SecurityAccess	No LIN-specific requirements	—
CommunicationControl	LIN-specific requirements	see 7.2.1
TesterPresent	No LIN-specific requirements	—
ResponseOnEvent	LIN-specific requirements	see 7.2.2
ControlDTCSetting	No LIN-specific requirements	—
Data transmission functional unit		
ReadDataByIdentifier	No LIN-specific requirements	—
WriteDataByIdentifier	No LIN-specific requirements	—
Stored data transmission functional unit		
ClearDiagnosticInformation	No LIN-specific requirements	—
ReadDTCInformation	No LIN-specific requirements	—
Input/Output control functional unit		
InputOutputControlByIdentifier	No LIN-specific requirements	—
Remote activation of routine functional unit		
RoutineControl	No LIN-specific requirements	—
Upload/Download functional unit		
RequestDownload	No LIN-specific requirements	—
RequestUpload	No LIN-specific requirements	—
TransferData	No LIN-specific requirements	—
RequestTransferExit	No LIN-specific requirements	—
RequestFileTransfer	No LIN-specific requirements	—

NOTE Services which are not listed in [Table 3](#) are not supported.

7.2 Diagnostic and communication control functional unit

7.2.1 CommunicationControl (0x28) service

[Table 4](#) defines LIN-specific CommunicationControl (0x28) service requirements.

Table 4 — LIN-specific CommunicationControl (0x28) service requirements

CommControl.Requirement	Requirement description
Master_CC.Req1	The LIN master node shall implement the service CommunicationControl as specified in ISO 14229-1 to allow for LIN cluster specific activation and de-activation of message type “normal communication” (see Table 5). NOTE The command to enable and disable the diagnostics-only mode is the diagnostic service CommunicationControl (see ISO 14229-1) with the parameter CommunicationType set to “Normal Communication Messages”.

[Table 5](#) defines the CommunicationControl (0x28) service and associated scheduling.

Table 5 — CommunicationControl (0x28) service and associated scheduling

Normal communication	Active scheduling
enabled	Interleaved diagnostics
	Scheduling active for the LIN cluster(s) requested through the parameter “nodeIdentificationNumber” of the diagnostic service CommunicationControl.
disabled	Diagnostics-only
	Scheduling active for the LIN cluster(s) requested through the parameter “nodeIdentificationNumber” of the diagnostic service CommunicationControl.

7.2.2 ResponseOnEvent (0x86) service

[Table 6](#) defines LIN-specific diagnostic service requirements.

Table 6 — LIN-specific ResponseOnEvent (0x86) service requirements

ResponseOnEvent.Requirement	Requirement description
Master_ROE.Req1	The master node shall provide a ResponseHeader in order to enable the slave to provide a ServiceToRespondTo in case the specified event occurred (see ISO 14229-1). This has to be considered for LIN-schedule definition in case the slave node’s diagnostic implementation requires a ResponseOnEvent service.

8 Application layer requirements

8.1 Application layer services

This part of ISO 14229 uses the application layer services as defined in ISO 14229-1 for client-server based systems to perform functions such as test, inspection, monitoring, diagnosis, or programming of on-board vehicle servers.

The message length of an UDSONLIN message is specified in ISO 17987-2.

The message buffer is controlled by the session layer and requested by the data link layer when a message start is detected and as soon as the message length is available.

The master node shall synchronize with all its slave nodes the maximum amount of receive buffer based on the data length specified in order to store all data transmitted.

Certain diagnostic services, e.g. ReadDTCInformation, might exceed the message length restriction (depends on the number of DTCs to be reported). In such case, the negative response handling applies as specified in ISO 14229-1 for each concerned service.

8.2 Application layer protocol

This part of ISO 14229 uses the application layer protocol as defined in ISO 14229-1.

8.3 Application layer timing

8.3.1 General

The subclauses specify the application and session layer timing parameters and how those apply to the client and the server.

8.3.2 Application layer timing parameter values

The LIN master and slave node application timing requirements for diagnostic message exchange shall be implemented according to ISO 17987-2.

$P2_{Server_max}$ shall be handled in the session layer according to ISO 14229-2.

Due to timing performance requirements for emissions-related systems, it is not recommended to connect an emissions-related primary ECU to a LIN cluster, if the LIN slaves have any impact on the emissions-related communication, i.e. providing emissions relevant data for the emissions-related communication.

It is the vehicle manufacturer's responsibility to ensure that in case the client does not require a response message [suppressPosRspMsgIndicationBit = TRUE ('1')] and the server might need more than $P2_{Server}$ to process the request message that the client shall insert sufficient time between subsequent requests.

Depending on the choice of implementation, there are two possibilities:

- request mirrored to LIN can be sent immediately after the FirstFrame is received by the master node, and
- master node receives the request in total and forwards it to the slave node.

It is the master node's responsibility to use appropriate scheduling or schedule tables to provide the required data to the slave node and to receive the slave node responses.

NOTE 1 The time the FF is provided on LIN depends on the schedule (use of 0x3C frame identifier).

NOTE 2 The number of CFs on LIN might differ (± 1) to those on client/master-side due to Transport Protocol definitions in ISO 17987-4.

[Figure 2](#) shows the timing sequence chart of UDSONLIN through a DoCAN backbone bus.

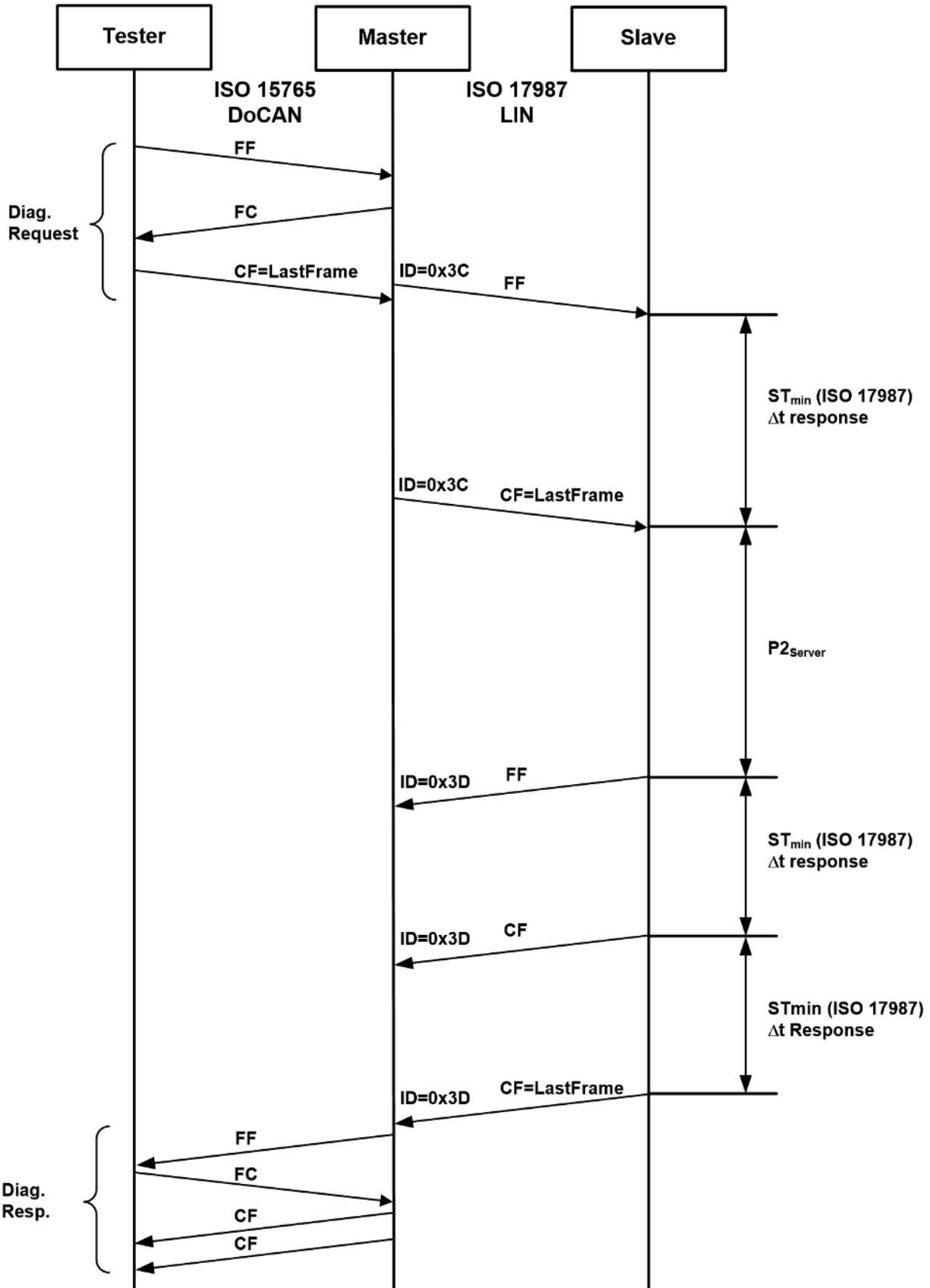

Figure 2 — Timing sequence chart of UDSONLIN through a DoCAN backbone bus

9 Presentation layer requirements

The presentation layer requirements are in the responsibility of the vehicle manufacturer.

10 Session layer requirements

The session layer requirements are specified in ISO 14229-2.

11 Transport/network layer interface adaptation

11.1 General information

This part of ISO 14229 makes use of the network layer services defined in ISO 14229-2 for the transmission and reception of diagnostic messages. This clause defines the mapping of the data link independent transport/network layer protocol data units (T_PDU) onto the LIN data link specific network layer protocol data units (N_PDU).

Full transport protocol layer implementation is required to support multi frame-based message transmissions (see ISO 17987-2).

NOTE The transport/network layer services are used to perform the application layer and diagnostic session management timing.

11.2 LIN transport/network layer interface adaptation

11.2.1 Mapping of data link independent service primitives onto LIN data link dependent service primitives

[Table 7](#) specifies the mapping interface between the ISO 17987-2 and the session layer services defined in ISO 14229-2 for the transmission and reception of diagnostic messages.

Table 7 — Mapping of T_PDU service primitives onto network N_PDU service primitives

Session to transport/network layer service primitives (data link independent according to ISO 14229-2)	LIN network layer service primitives (data link dependent according to ISO 17987-2)
T_Data.indication	N_USData.indication
T_DataSOM.indication	N_USDataFF.indication
T_Data.confirm	N_USData.confirm
T_Data.request	N_USData.request

The N_USData_FF.indication service primitive is mapped to T_DataSOM.indication to generally indicate start of reception of a multi-frame message on the LIN data link.

11.2.2 Mapping of T_PDU onto N_PDU for message transmission

The parameters of the application layer protocol data unit defined to request the transmission of a diagnostic service request/response are mapped in accordance with [Table 8](#) onto the parameters of the network layer protocol data unit for the transmission of a message in the client/server.

Table 8 — Mapping of T_PDU parameter onto the network N_PDU parameter

T_PDU parameter (data link independent according to ISO 14229-2)	N_PDU parameter (LIN data link dependent according to ISO 17987-2)
T_Mtype	N_Mtype
T_SA	not applicable
T_TA	N_TA
T_TAtype	N_TAtype
T_AE	not applicable
T_Data []	< MessageData >
T_Length	< DataLength >
T_Result	< N_Result >

The network layer confirmation of the successful transmission of the message (N_USData.con) is forwarded to the application, because it is needed in the application for starting those actions, which shall be executed immediately after the transmission of the request/response message (ECUReset, BaudrateChange, etc.).

The address mapping between the network layer and the OSI higher layers is not necessarily an exact copy of the address values as encoded on the data link layer and, therefore, depends on the implementation concept.

The mapping is defined in ISO 17987-2.

12 Network layer diagnostic implementation requirements

12.1 LIN slave node network layer requirements

This part of ISO 14229 specifies LIN slave node network layer requirements depending on the diagnostic class (see [Table 9](#)).

Table 9 — LIN slave node network layer requirements according to diagnostic class

DiagnosticClass.Requirement	Requirement description
Slave_DiagClassI.Req1	There are no specific network layer requirements defined for a LIN slave node which complies to diagnostic class I.
Slave_DiagClassII.Req1	Each diagnostic class II LIN slave node shall implement the network layer requirements as specified in ISO 17987-2.
Slave_DiagClassII.Req2	Each diagnostic class II LIN slave node shall be assigned a fixed node address (NAD) during system design time. NOTE For LIN clusters using dynamic NAD assignment during network communication start-up, this implies that after NAD assignment has finished, all LIN slave nodes have their NADs assigned as specified during system design time.
Slave_DiagClassII.Req3	Each diagnostic class II LIN slave node shall ignore NAD 0x7E as broadcast (functional) address for diagnostic communication on the LIN cluster.
Slave_DiagClassIII.Req1	Each diagnostic class III LIN slave node shall implement the network layer requirements as specified in ISO 17987-2.

Table 9 (continued)

DiagnosticClass.Requirement	Requirement description
Slave_DiagClassIII.Req2	Each diagnostic class III LIN slave node shall be assigned a fixed node address (NAD) during system design time. NOTE For LIN clusters using dynamic NAD assignment during network communication start-up, this implies that after NAD assignment has finished, all LIN slave nodes have their NADs assigned as specified during system design time.
Slave_DiagClassIII.Req3	Each diagnostic class III LIN slave node shall support NAD 0x7E as broadcast (functional) address for diagnostic communication on the LIN cluster.

In case of multiple UDS LIN slave servers connected to a LIN cluster, it is not possible to retrieve responses on a functionally addressed request due to restriction on diagnostic communication over LIN through frame identifier 3C₁₆ (60_d master request frame).

In case of multiple UDS LIN slave servers connected to a LIN cluster, it is not possible to send parallel physical requests due to restriction on diagnostic communication over LIN through frame identifier 3D₁₆ (61_d slave response frame).

12.2 LIN master node network layer requirements

12.2.1 Network address requirements

This part of ISO 14229 specifies LIN master node network layer requirements (see [Table 10](#)).

Table 10 — LIN master node network layer requirements

DiagnosticClass.Requirement	Requirement description
Master_DiagClassIII.Req1	Each diagnostic class III LIN master node shall implement the network layer requirements as specified in ISO 17987-2.
Master_DiagClassIII.Req2	If dynamic NAD assignment is used on a LIN cluster, the LIN master node shall ensure that after communication start-up, all LIN slave nodes have their NADs assigned as specified according to Table 9 Slave_II.Req2 and Slave_III.Req2. The start-up configuration time necessary to complete NAD assignment shall be documented in the diagnostic specification of the master node. NOTE This implies that diagnostic communication between external diagnostic test equipment and a LIN slave node may not be possible until the LIN master node has completed the NAD assignment sequence.
Master_DiagClassIII.Req3	The LIN clusters connected to the LIN master node shall be assigned the subnet number 0x1, which is used by the diagnostic service Communication-Control.

12.2.2 Use of functional addressing

Functional addressing is used by the external test equipment (client to master LIN node) if the client does not know about the LIN architecture.

13 Data link layer diagnostic implementation requirements

This part of ISO 14229 makes use of the data link layer specification defined in ISO 17987-3 for the transmission and reception of diagnostic messages.

Bibliography

- [1] ISO 7498-1, *Information processing systems — Open Systems Interconnection — Basic reference model: The Basic Model*
- [2] ISO/IEC 10731, *Information technology — Open Systems Interconnection — Basic Reference Model — Conventions for the definition of OSI services*
- [3] ISO 11898-1, *Road vehicles — Controller area network (CAN) — Part 1: Data link layer and physical signalling*
- [4] ISO 11898-2, *Road vehicles — Controller area network (CAN) — Part 2: High-speed medium access unit*
- [5] ISO 13400 (all parts), *Road vehicles - Diagnostic communication over Internet Protocol (DoIP)*
- [6] ISO 15031-5, *Road vehicles — Communication between vehicle and external equipment for emissions-related diagnostics — Part 5: Emissions-related diagnostic services*
- [7] ISO 15031-6, *Road vehicles — Communication between vehicle and external equipment for emissions-related diagnostics — Part 6: Diagnostic trouble code definitions*
- [8] ISO 15765-2, *Road vehicles — Diagnostic communication over Controller Area Network (DoCAN) — Part 2: Transport protocol and network layer services*
- [9] ISO 15765-4, *Road vehicles — Diagnostic communication over Controller Area Network (DoCAN) — Part 4: Requirements for emissions-related systems*
- [10] ISO 27145 (all parts), *Road vehicles — Implementation of World-Wide Harmonized On-Board Diagnostics (WWH-OBD) communication requirements*
- [11] SAE J1930-DA, *Digital Annex of Electrical/Electronic Systems Diagnostic Terms, Definitions, Abbreviations, and Acronyms Web Tool Spreadsheet*
- [12] SAE J1939, *Companion Spreadsheet (CS1939)*
- [13] SAE J1939-73, *Recommended Practice for a Serial Control and Communication Vehicle Network — Application layer — Diagnostics, Appendix A*
- [14] SAE J1979-DA, *Digital Annex of E/E Diagnostic Test Modes*
- [15] SAE J2012-DA, *Digital Annex of Diagnostic Trouble Code Definitions and Failure Type Definitions*
- [16] ISO 17987 (all parts), *Road vehicles — Local Interconnect Network (LIN)*
- [17] ISO 10681-2, *Road vehicles — Communication on FlexRay — Part 2: Communication layer services*
- [18] ISO 17458-2, *Road vehicles — FlexRay communications system — Part 2: Data link layer specification*
- [19] ISO 17458-4, *Road vehicles — FlexRay communications system — Part 4: Electrical physical layer specification*
- [20] IEEE 802.3, *IEEE Standard for Ethernet*
- [21] ISO 14230-1, *Road vehicles — Diagnostic communication over K-Line (DoK-Line) — Part 1: Physical layer*
- [22] ISO 14230-2, *Road vehicles — Diagnostic communication over K-Line (DoK-Line) — Part 2: Data link layer*
- [23] ISO 14229 (all parts), *Road vehicles — Diagnostic systems — Diagnostic services specification*

