**Optics and photonics — Specifications
for telescopic sights —**

**Part 2:
High-performance instruments**

*Optique et photonique — Spécifications pour lunettes de pointage —
Partie 2: Instruments haute performance*





COPYRIGHT PROTECTED DOCUMENT

© ISO 2014

All rights reserved. Unless otherwise specified, no part of this publication may be reproduced or utilized otherwise in any form or by any means, electronic or mechanical, including photocopying, or posting on the internet or an intranet, without prior written permission. Permission can be requested from either ISO at the address below or ISO's member body in the country of the requester.

ISO copyright office
Case postale 56 • CH-1211 Geneva 20
Tel. + 41 22 749 01 11
Fax + 41 22 749 09 47
E-mail copyright@iso.org
Web www.iso.org

Published in Switzerland

Contents

	Page
Foreword	iv
1 Scope	1
2 Normative references	1
3 Terms and definitions	1
4 Classification	1
5 Interfaces	2
6 Fundamental requirements	2
7 Consumer information	4
7.1 Marking	4
7.2 Information brochures	4
7.3 Compliance	4
Annex A (informative) Recommended interface dimensions	6

Foreword

ISO (the International Organization for Standardization) is a worldwide federation of national standards bodies (ISO member bodies). The work of preparing International Standards is normally carried out through ISO technical committees. Each member body interested in a subject for which a technical committee has been established has the right to be represented on that committee. International organizations, governmental and non-governmental, in liaison with ISO, also take part in the work. ISO collaborates closely with the International Electrotechnical Commission (IEC) on all matters of electrotechnical standardization.

The procedures used to develop this document and those intended for its further maintenance are described in the ISO/IEC Directives, Part 1. In particular the different approval criteria needed for the different types of ISO documents should be noted. This document was drafted in accordance with the editorial rules of the ISO/IEC Directives, Part 2 (see www.iso.org/directives).

Attention is drawn to the possibility that some of the elements of this document may be the subject of patent rights. ISO shall not be held responsible for identifying any or all such patent rights. Details of any patent rights identified during the development of the document will be in the Introduction and/or on the ISO list of patent declarations received (see www.iso.org/patents).

Any trade name used in this document is information given for the convenience of users and does not constitute an endorsement.

For an explanation on the meaning of ISO specific terms and expressions related to conformity assessment, as well as information about ISO's adherence to the WTO principles in the Technical Barriers to Trade (TBT) see the following URL: [Foreword - Supplementary information](#)

The committee responsible for this document is ISO/TC 172, *Optics and photonics*, Subcommittee SC 4, *Telescopic systems*.

This second edition cancels and replaces the first edition ISO 14135-2:2003 which has been technically revised.

ISO 14135 consists of the following parts, under the general title *Optics and photonics — Specifications for telescopic sights*:

- *Part 1: General-purpose instruments*
- *Part 2: High-performance instruments*

Optics and photonics — Specifications for telescopic sights —

Part 2: High-performance instruments

1 Scope

This part of ISO 14135 applies to high-performance telescopic sights, used on hand-held firearms and airguns. It contains a classification of the usage of telescopic sights and specifies interfaces, minimum requirements, and tolerances to their performances.

General-purpose telescopic sights are specified in ISO 14135-1.

2 Normative references

The following documents, in whole or in part, are normatively referenced in this document and are indispensable for its application. For dated references, only the edition cited applies. For undated references, the latest edition of the referenced document (including any amendments) applies.

ISO 10109-4, *Optics and optical instruments — Environmental requirements — Part 4: Test requirements for telescopic systems*

ISO 14132-1, *Optics and photonics — Vocabulary for telescopic systems — Part 1: General terms and alphabetical indexes of terms in ISO 14132*

ISO 14132-3, *Optics and photonics — Vocabulary for telescopic systems — Part 3: Terms for telescopic sights*

ISO 14490-1, *Optics and optical instruments — Test methods for telescopic systems — Part 1: Test methods for basic characteristics*

ISO 14490-3, *Optics and optical instruments — Test methods for telescopic systems — Part 3: Test methods for telescopic sights*

ISO 14490-5, *Optics and optical instruments — Test methods for telescopic systems — Part 5: Test methods for transmittance*

ISO 14490-7, *Optics and optical instruments — Test methods for telescopic systems — Part 7: Test methods for limit of resolution*

3 Terms and definitions

For the purposes of this document, the terms and definitions given in ISO 14132-1 and ISO 14132-3 apply.

4 Classification

Due to different requirements, telescopic sights shall be classified according to their end use, thus:

- telescopic sights for airguns;
- telescopic sights for pistols (e.g. handgun scopes);
- telescopic sights for rifles (e.g. hunting telescopic sights).

5 Interfaces

Telescopic sights shall have interfaces to mounting systems for interconnection with firearms.

The interface areas shall be the central tube and, if of different size, the objective tube.

The interface areas shall be cylindrical in shape. Alternatively, the central tube may have a dovetail at the bottom side.

Recommended interface dimensions are shown in [Annex A](#).

For interface areas, see [Figure 1](#).

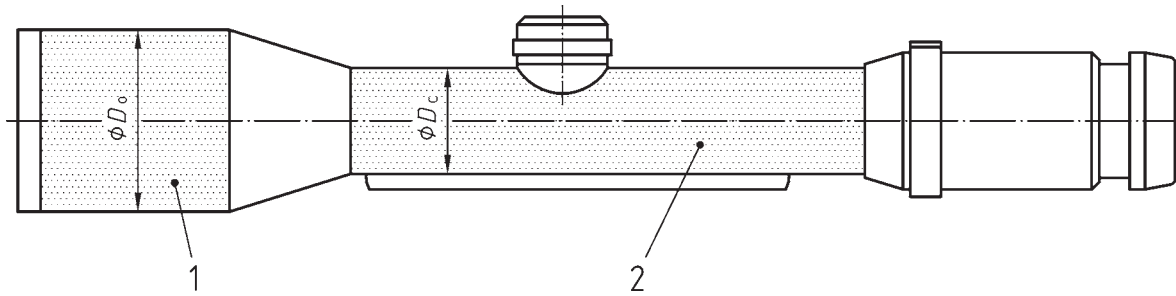

Key

- D_o diameter of objective tube
- D_c diameter of central tube
- 1 objective tube
- 2 central tube

Figure 1 — Interface areas (schematic)

6 Fundamental requirements

Fundamental requirements are defined by minimum values or tolerances for the important characteristics of telescopic sights.

Tolerances specify maximum deviations between measured and nominal values. Nominal values shall be laid down by the manufacturing or trading company.

Telescopic sights shall comply with the environmental requirements relative to the respective instrument type, as appropriate. These environmental requirements are specified in ISO 10109-4.

Compliance of the telescopic sight with the requirements given in [Table 1](#) and [Table 2](#) shall be tested according to the test methods specified in ISO 14490-1, ISO 14490-3, ISO 14490-5, and ISO 14490-7.

Table 1 — Minimum values for characteristics of high-performance telescopic sights

Characteristics	Type of telescopic sight	Minimum value/requirement
Eye relief, in millimetres	For airguns	50
	For pistols	250
	For rifles	70
a D is the entrance pupil diameter, in millimetres, in accordance with ISO 14132-1. b Γ is the magnification in accordance with ISO 14132-1. c Independent for both elevation and windage adjustment.		

Table 1 (continued)

Characteristics	Type of telescopic sight	Minimum value/requirement
Resolution, in arc seconds (exit pupil ≤4,5 mm)	All	centre ≤300/D ^a
Resolution, in arc seconds (exit pupil >4,5 mm)	For airguns	≤2 × 60/Γ ^b
	For pistols	≤1,2 × 60/Γ
	For rifles	≤1,0 × 60/Γ
Dioptr adjustment range (total), in dioptr	For pistols or rifles	3
Total reticle adjustment range ^c , in arc minutes	For rifles or pistols	30
Transmission	All	Each glass-to-air surface shall be antireflection-coated.

^a D is the entrance pupil diameter, in millimetres, in accordance with ISO 14132-1.

^b Γ is the magnification in accordance with ISO 14132-1.

^c Independent for both elevation and windage adjustment.

Table 2 — Tolerances for characteristics of high-performance telescopic sights

Characteristics	Type of telescopic sight	Maximum deviation		
		Γ ≤ 3	Γ > 3	Zoom
Magnification	All	±5 %	±3 %	±5 %
Field of view	All	±5 %	±3 %	±5 %
Entrance pupil diameter ^a	For airguns	±5 %		
	For rifles or pistols	±3 %		
Zero setting of dioptr scale ^b , in dioptr	All	Γ ≤ 2	Γ > 2	
		not required	±0,25	
Parallax of reticle ^c , in arc minutes		Γ < 6	Γ ≥ 6	
	For airguns	4/Γ	—	
	For pistols	3/Γ	—	
	For rifles	2/Γ	0,3	
Centre of reticle ^d , in relation to total field of view	For airguns	±1,0 %		
	For rifles or pistols	±0,7 %		
Reticle tilt, in degrees	All	±2		
Reticle tracking, in degrees	For rifles or pistols	±2		
Line of sight shift due to zooming ^e , in arc minutes	Reticle in 1st image plane	—		
	Reticle in 2nd image plane ^e	Γ ≤ 2	2 < Γ ≤ 6	Γ > 6
		1,5	3/Γ	0,5

^a At maximum magnification on zoom-telescopic sights.

^b This tolerance includes focus shift due to zooming.

^c Angular deviation in object space.

^d In relation to centre of field of view.

^e Γ is the minimum magnification of the zoom system.

7 Consumer information

7.1 Marking

For identification and operation, telescopic sights shall have, as a minimum, the markings listed in [Table 3](#).

Table 3 — Marking

Characteristics	Marking	
	Required	Recommended
Magnification or range of magnification ^a	×	
Entrance pupil diameter ^a	×	
Name of manufacturer or registered trade mark	×	
Product name or identification		×
Country of origin		×
Serial number		×
Position for zero dioptré		×
Value of reticle adjustment per click		×
Direction of adjustment for point of impact		×

^a Basic designation is given by the combination of magnification and diameter of entrance pupil, e.g. 6 × 42 or 3 – 10 × 50.

7.2 Information brochures

Product catalogues, user manuals, and other technical information brochures for telescopic sights shall provide complete information at least on the technical characteristics given in [Table 4](#).

7.3 Compliance

Products complying with the requirements given in this part of ISO 14135 may be designated as “*High-performance instruments in accordance with this International Standard, i.e. ISO 14135-2*”.

NOTE Products complying with the requirements given in ISO 14135-1 may be designated as “*General-purpose instruments in accordance with ISO 14135-1*”.

Table 4 — Product information

Characteristics	Information	
	Required	Recommended
Magnification or range of magnification	×	
Entrance pupil diameter (mm)	×	
Name of manufacturer or registered trade mark	×	
Product name or identification	×	
Country of origin		×
Field of view (m/100 m or ft/100 yd or degree)	×	
Exit pupil diameter (mm)	×	
Resolution or MTF		×
Light transmission		×
Type of coating		×

Table 4 (continued)

Characteristics	Information	
	Required	Recommended
Twilight number		×
Eye relief range (mm)	×	
Dimension/subtense of reticles		×
Parallax-free distance (m or yd)	×	
Total reticle adjustment range		×
Value of reticle adjustment per click	×	
Direction of adjustment for point of impact		×
Mechanical dimensions (mm)	×	
Mass	×	
Operational temperature range		×
Storage temperature range		×
Watertightness	×	

Annex A (informative)

Recommended interface dimensions

For recommended interface dimensions, see [Table A.1](#).

Table A.1 — Recommended interface dimensions

Shape	Dimension ^a		Tolerance	Application
	D_c	D_o		
Cylindrical	19 mm or 22 mm	All	$\pm 0,1$ mm	For airguns
Cylindrical	25,4 mm (1 in) or 30 mm	All	$\pm 0,1$ mm	For handguns
Cylindrical	25,4 mm (1 in) or 30 mm	1 in, 26 mm, 30 mm, 36 mm; for $D_o > 36$ mm every integer value in mm	$\pm 0,1$ mm	For rifles
With dovetail (see Figure A.1)	Manufacturer's specification	1 in, 26 mm, 30 mm, 36 mm; for $D_o > 36$ mm every integer value in mm	$\pm 0,1$ mm	For rifles

^a D_c is the central tube diameter; D_o is the objective tube diameter.

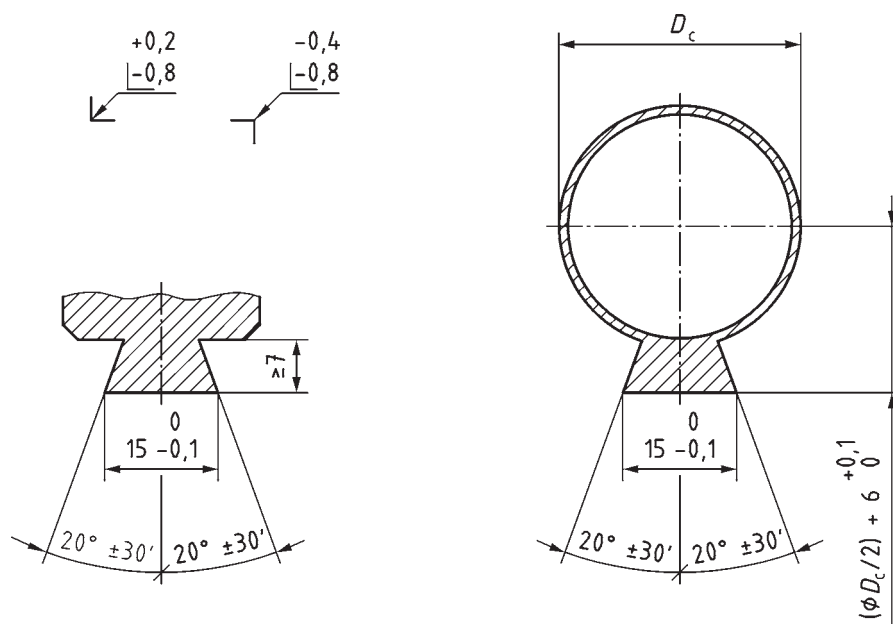

Figure A.1 — Example of central tube with dovetail (cross section)

11/01/2014 03:48:56 MDT

