**Fibre-reinforced plastic composites —
Determination of apparent interlaminar
shear strength by short-beam method**

*Composites plastiques renforcés de fibres — Détermination de
la résistance au cisaillement interlaminaire apparent par essai de flexion
sur appuis rapprochés*



Foreword

ISO (the International Organization for Standardization) is a worldwide federation of national standards bodies (ISO member bodies). The work of preparing International Standards is normally carried out through ISO technical committees. Each member body interested in a subject for which a technical committee has been established has the right to be represented on that committee. International organizations, governmental and non-governmental, in liaison with ISO, also take part in the work. ISO collaborates closely with the International Electrotechnical Commission (IEC) on all matters of electrotechnical standardization.

Draft International Standards adopted by the technical committees are circulated to the member bodies for voting. Publication as an International Standard requires approval by at least 75 % of the member bodies casting a vote.

International Standard ISO 14130 was prepared by Technical Committee ISO/TC 61, *Plastics*, Subcommittee SC 13, *Composites and reinforcement fibres*.

It cancels and replaces International Standard ISO 4585:1989. The main changes are as follows:

The scope of ISO 4585 has been extended to include all current and future textile-diameter fibre-reinforced plastic composites which fail in the required manner, with an additional requirement for a standard specimen thickness of 2 mm. The 3 mm thick specimen is still available as an alternative using the specimen scaling rules given in 6.1.2, but, although the test span at 15 mm is the same as previously, the width is now 15 mm (cf. 10 mm previously).

© ISO 1997

All rights reserved. Unless otherwise specified, no part of this publication may be reproduced or utilized in any form or by any means, electronic or mechanical, including photocopying and microfilm, without permission in writing from the publisher.

International Organization for Standardization
Case postale 56 • CH-1211 Genève 20 • Switzerland
Internet central@iso.ch
X.400 c=ch; a=400net; p=iso; o=isocs; s=central

Printed in Switzerland

Fibre-reinforced plastic composites — Determination of apparent interlaminar shear strength by short-beam method

1 Scope

1.1 This International Standard specifies a procedure for determining the apparent interlaminar shear strength of fibre-reinforced plastic composites by the short-beam method.

1.2 The method is suitable for use with fibre-reinforced plastic composites with a thermoset or a thermoplastic matrix, providing interlaminar shear failure is obtained.

NOTE — When using other than laminated materials which are not symmetrical and balanced, the results may be affected by various couplings such as extension/bending, bending/twisting, etc.

1.3 The method is not suitable for the determination of design parameters, but may be used for screening materials, or as a quality-control test.

2 Normative references

The following standards contain provisions which, through reference in this text, constitute provisions of this International Standard. At the time of publication, the editions indicated were valid. All standards are subject to revision, and parties to agreements based on this International Standard are encouraged to investigate the possibility of applying the most recent editions of the standards indicated below. Members of IEC and ISO maintain registers of currently valid International Standards.

ISO 291:1997, *Plastics — Standard atmospheres for conditioning and testing*.

ISO 1268:1974, *Plastics — Preparation of glass fibre reinforced, resin bonded, low-pressure laminated plates or panels for test purposes*.¹⁾

ISO 2602:1980, *Statistical interpretation of test results — Estimation of the mean — Confidence interval*.

ISO 2818:1994, *Plastics — Preparation of test specimens by machining*.

ISO 5893:1993, *Rubber and plastics test equipment — Tensile, flexural and compression types (constant rate of traverse) — Description*.

¹⁾ Under revision.

3 Principle

A bar of rectangular cross-section is loaded as a simple beam in flexure so that interlaminar shear failure occurs. The bar rests on two supports and the load is applied by means of a loading member midway between the supports.

NOTES

1 The test is similar in nature to the three-point loading method used to determine the flexural properties of plastics (ISO 14125, *Fibre-reinforced plastic composites — Determination of flexural properties*). However, a smaller test span/specimen thickness ratio is adopted to increase the level of shear stress relative to the flexural stress in the test specimen to encourage interlaminar shear failure.

2 It is emphasized that the result obtained is not an absolute value. For this reason the term “apparent interlaminar shear strength” is used to define the quantity measured. Test results from different-sized specimens, or from specimens tested under different conditions, are not directly comparable.

4 Definitions

For the purposes of this International Standard, the following definitions apply:

4.1 apparent interlaminar shear stress, τ : The interlaminar shear stress acting on the neutral plane of the specimen.

It is calculated from the relationship given in 10.1 and is expressed in megapascals (MPa).

4.2 apparent interlaminar shear strength, τ_M : The value of the apparent interlaminar shear stress at failure or when the load reaches a maximum value.

It is expressed in megapascals (MPa).

4.3 span, L : The distance between the two specimen supports in the test machine.

It is expressed in millimetres (mm).

4.4 specimen coordinate axes (for aligned materials): The coordinate axes for the material under test are defined in figure 1. The direction parallel to the fibre axes is defined as the “1” direction and the direction perpendicular to it the “2” direction.

For other materials, the 1, 2 and 3 directions are generally described by the x, y, z system of coordinates.

NOTES

1 The “1” direction is also referred to as the 0 degree (0°) or longitudinal direction, and the “2” direction as the 90 degree (90°) or transverse direction.

2 A similar definition can be used for material with a preferred fibre lay-up or in cases where a direction (e.g. the lengthwise direction) can be related to the production process (i.e. directions A and B in figure 3).

5 Apparatus

5.1 Test machine

5.1.1 General

The machine shall conform to ISO 5893 as appropriate to the requirements given in 5.1.2 and 5.1.3.

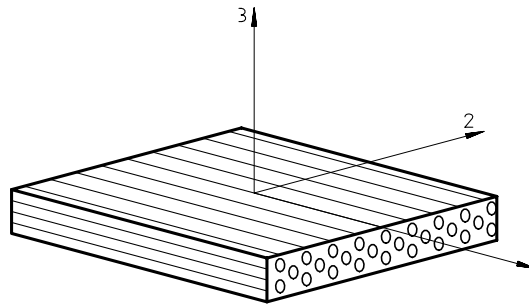

Figure 1 — Unidirectional reinforced composite plate element showing symmetry axes

5.1.2 Speed of testing

The speed of testing v shall be kept constant in accordance with ISO 5893.

5.1.3 Load indicator

The load indicator shall be such that the error in the indicated load is less than $\pm 1\%$ of full scale (see ISO 5893).

5.2 Loading member and supports

The radius of the loading member r_1 shall be $5\text{ mm} \pm 0,2\text{ mm}$ and that of the supports r_2 shall be $2\text{ mm} \pm 0,2\text{ mm}$ (see figure 2).

The width of the loading member and the supports shall be greater than the test specimen width. The loading member shall apply the load mid-way between the supports. The span (distance between the supports) shall be adjustable.

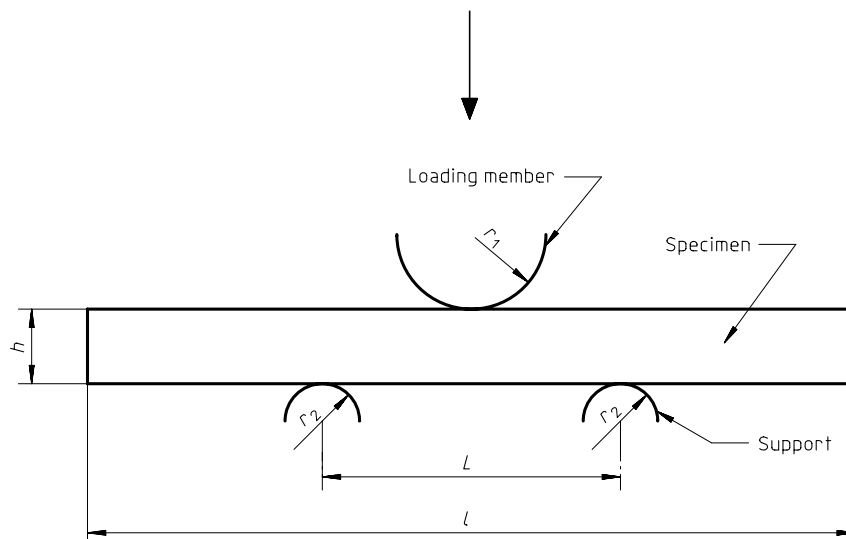

Figure 2 — Loading configuration

5.3 Micrometer, or equivalent, capable of reading to $0,01\text{ mm}$ or less, and suitable for measuring the width b and thickness h of the test specimen.

The micrometer shall have contact faces appropriate to the surface being measured (i.e. flat faces for flat, polished surfaces and hemispherical faces for irregular surfaces).

6 Test specimens

6.1 Shape and dimensions

6.1.1 Standard specimen size

Unless 6.1.2 applies, test specimens shall comprise rectangular bars of uniform thickness with the dimensions given in table 1.

Table 1

Thickness, h mm	Overall length, l mm	Width, b mm
$2 \pm 0,2$	20 ± 1	$10 \pm 0,2$

6.1.2 Other test specimens

When it is not possible or not desirable to use the standard specimen, the following rules shall be observed:

- the length and the thickness of the test specimen shall be in the same ratio as in the standard specimen, i.e.

$$l = 10h$$

- the width shall be chosen in the same ratio to the thickness as in the standard specimen, i.e.

$$b = 5h$$

NOTE — Depending upon the material being tested, specimens of 2 mm thickness may fail by shear or experience compression failure under load or exhibit extreme deflection without shear failure. As specimen thickness (height) is increased, the probability of compression failure under load increases and the probability of extreme deflection with no failure decreases. As specimen thickness is decreased, the reverse is true. It is important to select a specimen thickness that will cause specimens to fail by horizontal shear (see 9.7).

6.2 Preparation of specimens

Machine the test specimens from a moulded blank or sheet, prepared in accordance with ISO 1268 or another specified/agreed procedure. Some parameters for machining are given in ISO 2818.

6.3 Checking the test specimens

The specimens shall be flat and free of twist. The surfaces and edges shall be free from defects. The thickness along the whole length shall be within $\pm 5\%$ of the mean thickness. The width of individual specimens shall be constant to within 0,2 mm.

Specimens showing measurable or observable departure from one or more of these requirements shall be rejected or machined to the required size and shape before testing.

7 Number of test specimens

7.1 At least five test specimens shall be tested.

7.2 When the fibre orientation and distribution in the material to be tested does not differ significantly between the two principal directions, shear specimens shall be taken in each of these two directions (see figure 3, specimens A and B). When the material has a preferred orientation, the specimens shall be taken in this direction.

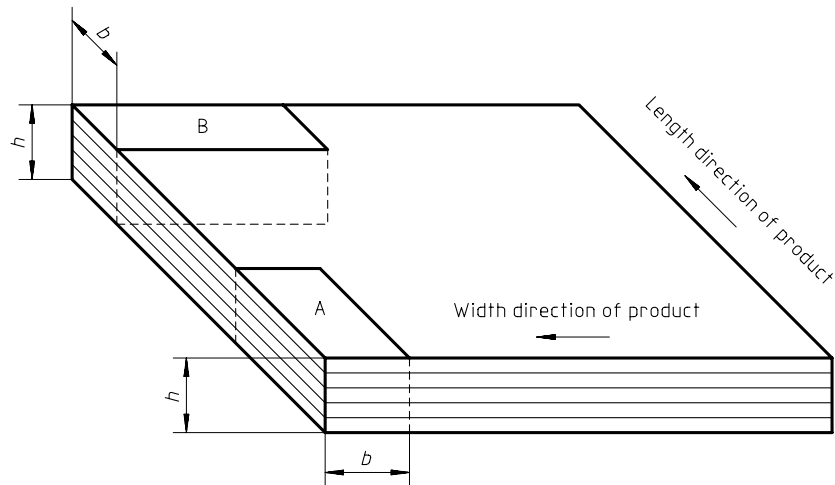

Figure 3 — Location of specimens

8 Conditioning

Where applicable, condition the test specimens as specified in the standard for the material under test. In the absence of such information, select the most appropriate conditions from ISO 291, unless agreed otherwise by the interested parties.

9 Procedure

9.1 Test atmosphere

Conduct the test in the same atmosphere as that used for conditioning unless agreed otherwise by the interested parties (e.g. for testing at elevated or reduced temperatures).

9.2 Measurement of specimen dimensions

Measure, at the mid-point of each test specimen, the width of the specimen to the nearest 0,02 mm and the thickness to the nearest 0,05 mm.

9.3 Span

Set the span L to $5h \pm 0,3$ mm, where h is the mean thickness of the set of specimens (see figure 2).

NOTE — For some materials, a shorter span may be necessary to produce interlaminar shear failure (see 9.7).

9.4 Speed of testing

Where applicable, set the speed of testing as given in the standard for the material being tested. In the absence of this information, the speed of testing v shall be $1 \text{ mm/min} \pm 0,2 \text{ mm/min}$.

9.5 Actual testing

Place the test specimen symmetrically across the two parallel supports with an unmachined surface in contact with the supports (see figure 2). Apply the force uniformly across the width of the test piece by means of the loading member, parallel to and midway between the supports.

9.6 Data collection

Record the force throughout the test.

9.7 Mode of failure

Record the mode of failure using the following classification:

Acceptable interlaminar shear failure modes:

- a) single shear, multiple shear [see figure 4a)].

Unacceptable failure modes:

- b) mixed modes of failure [see figure 4b)]: shear and tension, shear and compression;
- c) non-shear modes of failure [see figure 4c)]: tension, compression;
- d) plastic shear [see figure 4d)].

NOTE — There are two possible failure cases:

- for failure by mode “a”, approximately in the plane of the neutral axis, the apparent interlaminar shear strength can be calculated as shown in 10.1;
- for failure by modes “b” and “c”, the result calculated in accordance with 10.1 is not an interlaminar shear strength and may only be used to compare test specimens taken from the same material.

10 Calculation and expression of results

10.1 Calculate the apparent interlaminar shear strength τ , expressed in megapascals, using the following equation:

$$\tau = \frac{3}{4} \times \frac{F}{bh}$$

where

- F is the failure or maximum load, in newtons;
- b is the width, in millimetres, of the test specimen;
- h is the thickness, in millimetres, of the test specimen.

10.2 Calculate the arithmetic mean of the individual determinations and, if required, the standard deviation using the procedure given in ISO 2602.

10.3 Calculate the apparent interlaminar shear stress to three significant figures.

11 Precision

The precision of this test method is not known because interlaboratory data are not available. When interlaboratory data are obtained, a precision statement will be added at the following revision. This method may not be suitable for use in specifications or in the case of disputed results as long as these data are not available.

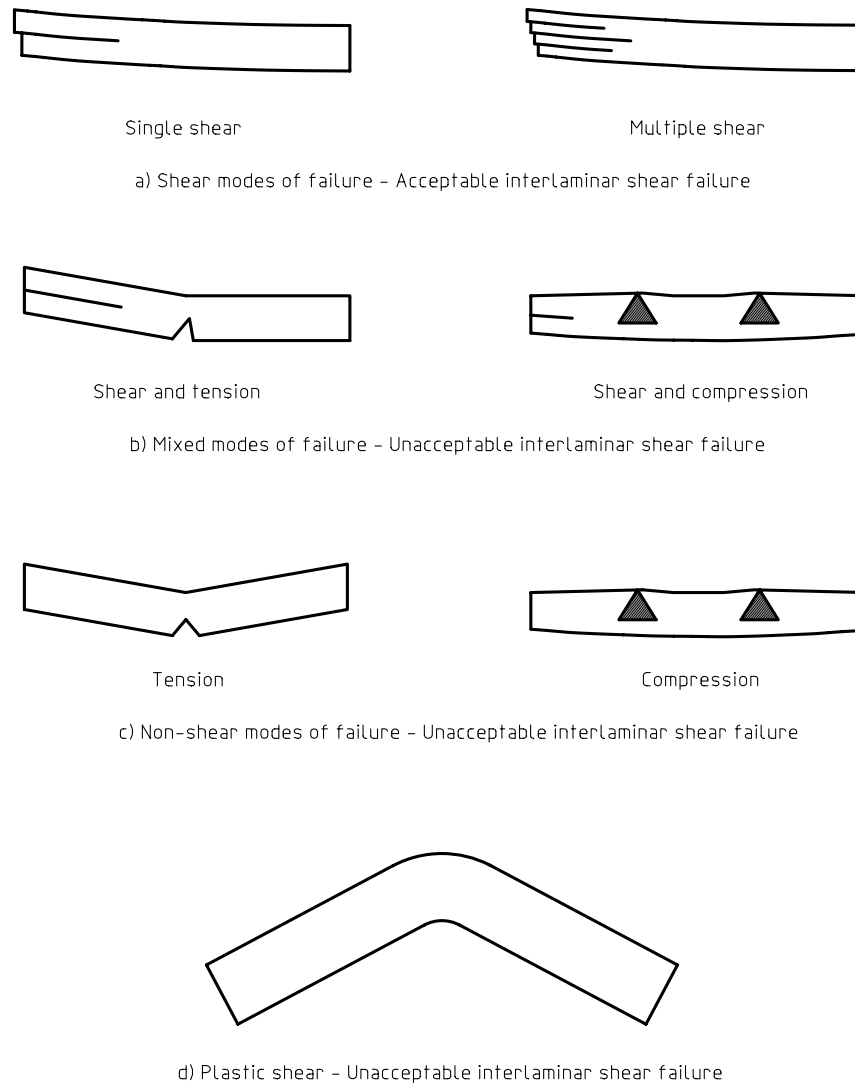

Figure 4 — Modes of failure

12 Test report

The test report shall include the following information:

- a) a reference to this International Standard and the test speed (e.g. ISO 14130/1);
- b) all details necessary for complete identification of the material tested, including type, source, manufacturer's code number, form and previous history, where these are known;
- c) the accuracy grading of the test machine (see ISO 5893);
- d) the radius of the loading member and that of the supports;
- e) all relevant information on the preparation of the test specimens, including information on the direction of cutting/testing (e.g. specimen A or B in figure 3, or direction 1 or 2);
- f) the dimensions of the test specimens;
- g) the number of specimens tested;

- h) the test conditions and the conditioning procedures, if applicable;
- i) the span used;
- j) the specimen surface in contact with the loading member;
- k) for test specimens which failed by interlaminar shear [see 9.7 and figure 4a)], the mode of failure (single or multiple shear), plus the individual apparent interlaminar shear strength values, their arithmetic mean and, if required, the standard deviation;
- l) for test specimens which did not fail by interlaminar shear [see 9.7 and figures 4b), 4c) and 4d)], a full description of the mode of failure together with the statement that the calculated values are not apparent interlaminar shear strengths, plus the individual values, their arithmetic mean and, if required, the standard deviation;
- m) any operation not specified in this International Standard, as well as any incident likely to have affected the results;
- n) the date of the test.

ICS 83.120

Descriptors: plastics, reinforced plastics, tests, shear tests, determination, shear strength, test specimens.

Price based on 8 pages
