

INTERNATIONAL
STANDARD

ISO
14126

First edition
1999-09-01

**Fibre-reinforced plastic composites —
Determination of compressive properties in
the in-plane direction**

*Composites plastiques renforcés de fibres — Détermination des
caractéristiques en compression dans le plan*



Reference number
ISO 14126:1999(E)

Contents

1 Scope	1
2 Normative references	2
3 Definitions	2
4 Principle	3
5 Apparatus	3
5.1 Test machine	3
5.1.1 General	3
5.1.2 Speed of testing	4
5.1.3 Indication of load	4
5.2 Strain measurement	4
5.3 Micrometer	4
5.4 Loading fixtures	4
5.4.1 General	4
5.4.2 Method 1: shear loading	4
5.4.3 Method 2: end loading	4
6 Test specimens	4
6.1 Shape and dimensions	4
6.1.1 Type A specimen	4
6.1.2 Type B specimen	5
6.2 Preparation	5
6.2.1 General	5
6.2.2 End-tab material	5
6.2.3 Application of end tabs	5

© ISO 1999

All rights reserved. Unless otherwise specified, no part of this publication may be reproduced or utilized in any form or by any means, electronic or mechanical, including photocopying and microfilm, without permission in writing from the publisher.

International Organization for Standardization
Case postale 56 • CH-1211 Genève 20 • Switzerland
Internet iso@iso.ch

Printed in Switzerland

6.2.4 Machining the specimens	5
6.3 Checking	6
7 Number of test specimens	6
8 Conditioning	6
9 Procedure	6
10 Expression of results	7
11 Precision	8
12 Test report	8
Annex A (normative) Specimen preparation	12
Annex B (informative) Compression fixtures for method 1	14
Annex C (informative) Compression fixtures for method 2	15
Annex D (informative) Euler buckling criteria	17
Bibliography	18

Foreword

ISO (the International Organization for Standardization) is a worldwide federation of national standards bodies (ISO member bodies). The work of preparing International Standards is normally carried out through ISO technical committees. Each member body interested in a subject for which a technical committee has been established has the right to be represented on that committee. International organizations, governmental and non-governmental, in liaison with ISO, also take part in the work. ISO collaborates closely with the International Electrotechnical Commission (IEC) on all matters of electrotechnical standardization.

International Standards are drafted in accordance with the rules given in the ISO/IEC Directives, Part 3.

Draft International Standards adopted by the technical committees are circulated to the member bodies for voting. Publication as an International Standard requires approval by at least 75 % of the member bodies casting a vote.

International Standard ISO 14126 was prepared by ISO/TC 61, *Plastics*, Subcommittee SC 13, *Composites and reinforcement fibres*.

This first edition cancels and replaces ISO 8515:1991, which dealt only with glass-fibre-reinforced plastic composites.

Annex A forms a normative part of this International Standard. Annexes B to D are for information only.

Introduction

This standard is based on ISO 8515, with the scope extended to include all fibre-reinforced plastic composites, such as more recent composites based on carbon and aramid fibres, but retains the test conditions relevant for glass-fibre-reinforced systems. Other source documents consulted include ASTM D 3410 (buckling criteria, larger specimen width and longer gauge length), ASTM D 695 (modified version in SACMA SRM1), prEN 2850, CRAG 400, DIN 65380 and JIS K 7076 (see bibliography).

Several different types of jig, different materials and different specimen sizes are covered by these source documents. The table below presents examples, the specimen sizes being given as overall length \times gauge length \times width \times thickness, in millimetres.

ISO 8515 (GRP)	Celanese type $110 \times 13 \times 6,4 \times 2$	End block $120 \times 20 \times 10 \times (3 \text{ to } 10)$	
prEN 2850 (CFRP)	Celanese type $110 \times 10 \times 10 \times 2$	ASTM D 695 $80 \times 5 \times 12,5 \times 2$	Revision includes a machined specimen with co-cured tabs.
JIS K 7076 (CFRP)	ASTM D 695 $78 \times 8 \times 12,5 \times 2$	Celanese $134 \times 8 \times 6,5 \times 2$	ITTRI $108 \times 8 \times (6 \text{ to } 12,5) \times (1 \text{ to } 2)$
ASTM D 3410 (all fibres)	Celanese $140 \times 12 \times 6 \times \text{variable}$	ITTRI $140 \times (25 \text{ to } 12) \times (12 \text{ or } 25) \times \text{variable}$	
(equations/tables give required thickness for modulus, expected strength and gauge length)			
DIN 65380 (all fibres)	Celanese $112 \times 8 \times 6,35 \times 2$	ITTRI $112 \times 8 \times 6,35 \times 2$	
CRAG 400 (all fibres)	Celanese $110 \times 10 \times 10 \times 2$		
SACMA SRM1 (all fibres)	ASTM D 695 (modified) $80,8 \times 12,7 \times 4,8 \times [1 \text{ (unidir.) or } 3 \text{ (fabric)}]$		

These test methods use aspect ratios (height/thickness and height/width) for the gauge area covering a range of values, which appears undesirable in a test known to be susceptible to buckling failures. Also, new support jigs are still being developed. This International Standard harmonizes and rationalizes the current situation by:

- a) concentrating on the quality of the test by limiting the maximum bending-buckling strain allowable at failure (i.e. 10 % as recommended by ASTM — see also 5 % level in prEN 2850), so that it is possible to justify an axial-load analysis;
- b) allowing any design of jig to be used that meets this above requirement, using two methods of loading (i.e. shear and end loaded);
- c) standardizing on two specimen designs, one principally for unidirectional material and one for other materials (the chosen specimen can be used with either loading method);
- d) adding an informative note as annex D, which was proposed by ASTM for harmonization purposes, and is taken from ASTM D 3410 (in a modified form).

Fibre-reinforced plastic composites — Determination of compressive properties in the in-plane direction

1 Scope

1.1 This International Standard specifies two methods for determining compressive properties, in directions parallel to the plane of lamination, of fibre-reinforced plastic composites.

1.2 The compressive properties are of interest for specifications and quality-control purposes.

1.3 Two loading methods and two types of specimen are described. They are:

- Method 1: provides shear loading of the specimen (gauge length unsupported).
- Method 2: provides end loading, or mixed loading, of the specimen (gauge length unsupported).

NOTE For tabbed specimens end-loaded using method 2, some load is transferred into the specimen gauge length by shear through the tabs.

- Type A specimen: rectangular cross-section, fixed thickness, end-tabbed.
- Type B specimen: rectangular cross-section, range of thicknesses, untabbed or end-tabbed (two sizes available).

Any combination of test method and specimen may be used, provided that the requirements of subclause 9.8 are satisfied and that the specimen is representative of the material under test. These alternative test conditions will not necessarily give the same result.

The type A specimen is the preferred specimen for unidirectionally reinforced materials tested in the fibre direction. For other materials, the type A or B specimen may be used. The type B2 specimen is preferred for mat, fabric and other multidirectionally reinforced materials.

1.4 The methods are suitable for fibre-reinforced thermoplastic and thermosetting plastic composites.

Unreinforced and particle-filled plastics, as well as those reinforced with short fibres (less than 1 mm in length), are covered by ISO 604 (see bibliography).

1.5 The methods are performed using specimens which may be machined from a test panel made in accordance with ISO 1268 or equivalent methods, or from finished or semi-finished products.

1.6 The methods specify required dimensions for the specimen. Tests which are carried out on specimens of other dimensions, or on specimens which are prepared under different conditions, may produce results which are not comparable. Other factors, such as the speed of testing, the support fixture used and the condition of the specimens, can influence the results. Consequently, when comparative data are required, these factors must be carefully controlled and recorded.

1.7 Fibre-reinforced plastics are usually anisotropic. It is therefore often useful to cut test specimens in at least the two main directions of anisotropy, or in directions previously specified (for example a lengthwise direction associated with the production process).

2 Normative references

The following normative documents contain provisions which, through reference in this text, constitute provisions of this International Standard. For dated references, subsequent amendments to, or revisions of, any of these publications do not apply. However, parties to agreements based on this International Standard are encouraged to investigate the possibility of applying the most recent editions of the normative documents indicated below. For undated references, the latest edition of the normative document referred to applies. Members of ISO and IEC maintain registers of currently valid International Standards.

ISO 291:1997, *Plastics — Standard atmospheres for conditioning and testing*.

ISO 527-1:1993, *Plastics — Determination of tensile properties — Part 1: General principles*.

ISO 527-4:1997, *Plastics — Determination of tensile properties — Part 4: Test conditions for isotropic and orthotropic fibre-reinforced plastic composites*.

ISO 1268:1974, *Plastics — Preparation of glass fibre reinforced, resin bonded, low-pressure laminated plates or panels for test purposes* (under revision).

ISO 2602:1980, *Statistical interpretation of test results — Estimation of the mean — Confidence interval*.

ISO 3534-1:1993, *Statistics — Vocabulary and symbols — Part 1: Probability and general statistical terms*.

ISO 5893:1993, *Rubber and plastics test equipment — Tensile, flexural and compression types (constant rate of traverse) — Description*.

ISO 9353:1991, *Glass-reinforced plastics — Preparation of plates with unidirectional reinforcements by bag moulding*.

3 Definitions

For the purpose of this International Standard, the following definitions apply:

3.1 compressive stress

σ_c
the compressive force experienced by the test specimen at any particular moment divided by the initial cross-sectional area of the parallel-sided portion of the specimen

It is expressed in megapascals.

3.2 compressive strength compressive failure stress

σ_{cM}
the maximum compressive stress sustained by the specimen

It is expressed in megapascals.

3.3 compressive strain

ε_c
the ratio of the decrease in the distance between the gauge marks on the parallel-sided portion of the test specimen (due to a compressive force) to the initial distance between the gauge marks

It is expressed as a dimensionless ratio or in percent.

3.4 compressive failure strain

ε_{cM}
the longitudinal compressive strain at the compressive failure stress

It is expressed as a dimensionless ratio or in percent.

3.5 modulus of elasticity in compression chord modulus

E_c
the stress difference (σ'' minus σ') divided by the corresponding strain difference [ε'' (= 0,0025) minus ε' (= 0,0005)] (see subclause 10.2)

It is expressed in megapascals.

3.6 specimen coordinate axes

the coordinate axes for the material with the fibres preferentially aligned in one direction (see Figure 1)

The direction parallel to the fibre axes is defined as the "1"-direction and the direction perpendicular to the fibre axes the "2"-direction. For other materials, the "1"-direction is normally defined in terms of a feature associated with the production process, such as the long direction for a continuous-sheet process. The "2"-direction is again perpendicular to the "1" direction.

Results for specimens cut parallel to the "1"-direction are identified by the subscript "11" (e.g. E_{c11}). Similarly, results for specimens cut parallel to the "2"-direction are identified by the subscript "22" (e.g. E_{c22}).

NOTE The "1"-direction is also referred to as the 0° or longitudinal direction, and the "2"-direction as the 90° or transverse direction. More generally, the X , Y and Z (through-thickness) coordinate system for any material can be equated to the "1"-, "2"- and "3"-directions.

4 Principle

An axial force is applied to the unsupported length of a rectangular specimen held in a loading fixture, while the applied load and strain in this area are monitored. The test method concentrates on the quality of the axial deformation experienced by the specimen. Any loading fixture can be used, provided specimen failure occurs below a 10 % bending strain in the specimen.

The compressive load is applied to the material

- either by shear through end tabs (method 1);
- or by direct end loading of the specimen (method 2).

Method 2 using a tabbed specimen results in load introduction into the test area by a combination of direct compression and shear through the tabs.

NOTE It is important to realize that the test results obtained by these two methods are not necessarily comparable.

5 Apparatus

5.1 Test machine

5.1.1 General

The machine shall conform to ISO 5893 as appropriate to the requirements given in 5.1.2 and 5.1.3.

5.1.2 Speed of testing

The test machine shall be capable of maintaining the required speed of testing (see 9.5).

5.1.3 Indication of load

The error for the indicated load shall not exceed ± 1 %.

5.2 Strain measurement

Strain shall be determined by means of either strain gauges or suitable extensometers. Strain shall be measured on both faces of the specimens. Strain gauge elements shall be not more than 3 mm in length. The error for the indicated strain shall not exceed ± 1 % for type A and B1 specimens. The gauges, the surface preparation and the bonding agents used shall be chosen to give adequate performance with the materials being tested, and suitable strain-recording equipment shall be employed.

5.3 Micrometer

A micrometer, or equivalent, reading to less than or equal to 0,01 mm shall be used to determine the thickness h and width b of the test specimen.

The micrometer shall have faces appropriate to the surface being measured (i.e. flat faces for flat, polished surfaces and round faces for other cases).

5.4 Loading fixtures

5.4.1 General

Fixtures appropriate to the loading method chosen shall be used. The compression fixture shall load the specimen so that the requirement on allowable specimen bending given in 9.8 is met. The fixture used shall be identified in the test report.

5.4.2 Method 1: shear loading

The load is applied to the specimen by shear through the faces of the end tabs. It is permissible to use different types of grip and sleeve (trapezoidal, for example). Aligned hydraulic grips in aligned test machines are also acceptable. A schematic diagram of a compression fixture for shear loading is given in Figure 2.

NOTE Some method 1 fixtures in common use are shown in annex B, e.g. ASTM D 3410: method A (Celanese) and method B (ITTRI).

5.4.3 Method 2: end loading

The load is applied directly to the end of the specimen. For a tabbed specimen, loading is by a combination of end loading and shear loading through the tab. A schematic diagram of a compression fixture for shear loading is given in Figure 3.

NOTE 1 Some method 2 fixtures in common use are shown in annex C, e.g. ISO 8515 and ASTM D 695 (modified version in prEN 2850). The D 695 fixture gives a lower degree of support to the end of the specimen.

NOTE 2 The main aspect of the fixture design for both loading methods is the alignment (initial and throughout the test), and for method B of ASTM D 3410 a further important aspect is prevention of failure at the end of the specimen.

6 Test specimens

6.1 Shape and dimensions

6.1.1 Type A specimen

The specimen shall be straight-sided and of rectangular cross-section, with the dimensions given in Table 1 (see also Figure 4).

6.1.2 Type B specimen

The specimen shall be straight-sided and of rectangular cross-section, with the dimensions given in Table 1. End tabs shall be used if necessary to avoid failure at the loaded ends of the specimen.

Table 1 — Specimen dimensions

Dimensions in millimetres

Dimensions	Symbol	Type A specimen	Type B1 specimen	Type B2 specimen
Overall length (minimum)	l_0	110 ± 1	110 ± 1	125 ± 1
Thickness	h	$2 \pm 0,2$	$2 \pm 0,2$ to $10 \pm 0,2$	≥ 4
Width	b	$10 \pm 0,5$	$10 \pm 0,5$	$25 \pm 0,5$
Distance between end tabs/grips	L	10	10	25
Length of end tabs (minimum)	l_t	50	50 (if required)	50 (if required)
Thickness of end tabs	d_t	1	0,5 to 2 (if required)	0,5 to 2 (if required)

NOTE Requirements for specimen quality and parallelism of specimen and end tabs are given in subclause 6.3.

6.2 Preparation

6.2.1 General

A panel shall be prepared in accordance with ISO 1268, ISO 9353 or another specified/agreed procedure. Specimens cut from finished parts (for example, for quality control during manufacture or on delivery) shall be taken from flat areas of uniform thickness.

6.2.2 End-tab material

The ends of the specimen shall be reinforced, if necessary, with end tabs made preferably from a 0°/90° cross-ply or fabric laminate made from glass-fibre/resin with the fibre axes in the fabric set at $\pm 45^\circ$ to the specimen axis. The tab thickness shall be between 0,5 mm and 2 mm, with a tab angle of 90° (i.e. not tapered). If tab failure occurs under high end loads, the fibre axes in the tab shall be set at 0°/90° to the specimen axis.

Alternatives, such as tabs made from the material under test, mechanically fastened tabs, unbonded tabs or friction materials (emery paper, grit paper or fine-finish grip faces), shall be shown, before use, to give at least equal strength values (see ISO 527-1:1993, subclause 10.5) and no greater coefficient of variation (see ISO 3534-1) than the recommended tab material. When the test is carried out on untabbed specimens, the "distance between tabs" shall be taken to be the distance between the tabs of a corresponding tabbed specimen (see ISO 527-4:1997, type 3 specimen).

6.2.3 Application of end tabs

The end tabs shall be bonded to the specimen as shown in annex A.

NOTE This procedure can be used for individual specimens or groups of specimens.

6.2.4 Machining the specimens

Method 1: Machine the tab surfaces as necessary to ensure the tabs are symmetrical about the specimen centreline and parallel to each other.

Method 2: Machine the end faces of each specimen so that they are parallel to each other and perpendicular to the longitudinal axis of the specimen. The allowed deviation from parallel of the areas of the end-loading plates in

contact with the specimen ends is 0,1 % of the initial length of the specimen, i.e. the distance between the end-loading plates. Tabs, if used, shall be prepared as for method 1.

Some specimen-machining parameters are specified in ISO 2818. With unidirectionally reinforced materials, the test specimen shall be taken with its axis within 0,5° of the mean fibre axis.

NOTE Additional guidance on machining specimens is given in annex A.

6.3 Checking

The specimens shall be free of twist and shall have symmetrical pairs of parallel surfaces. The surfaces and edges shall be free from scratches, pits, sink marks and flash. The specimens shall be checked for conformity with these requirements by visual observation against straight edges, squares and flat plates, and by measuring with micrometer callipers. Specimens showing measurable or observable departure from one or more of these requirements shall be rejected or machined to the proper size and shape before testing.

7 Number of test specimens

7.1 At least five test specimens shall be tested in each direction of test. The number of measurements may be more than five if greater precision of the mean value is required.

It is possible to calculate this by means of the confidence interval (95 % probability, see ISO 2602).

7.2 The results from test specimens that rupture inside the grip end blocks or end tabs shall be discarded and new specimens tested in their place. Replacement specimens shall also be used if bending of the specimen exceeds the maximum value permitted in 9.8.

NOTE This test method can result in failures at the edge of the loading fixture or end tab rather than in the middle of the gauge length. These failures are acceptable, but consideration should be given to minimizing them by using a different type of loading fixture, tab, etc.

8 Conditioning

Condition the test specimens as specified in the International Standard for the material tested. In the absence of this information, select the most appropriate set of conditions from ISO 291, unless otherwise agreed upon by the interested parties, e.g. when testing at elevated or low temperatures.

9 Procedure

9.1 Conduct the test in the atmosphere specified in the International Standard for the material tested. In the absence of this information, select the most appropriate set of conditions from ISO 291, unless otherwise agreed upon by the interested parties, e.g. when testing at elevated or low temperatures.

9.2 Measure the width b of each test specimen to the nearest 0,1 mm and the thickness h to the nearest 0,02 mm.

9.3 Attach strain gauges, or extensometers, and set up the necessary strain-recording equipment. Two strain measurements (one on each face of the specimen, i.e. back-to-back) are required to ascertain that column bending is not occurring. Euler buckling is considered to have been detected if the strain on one face reverses (decreases) while the strain on the opposite face increases rapidly.

With batches of specimens greater than five, tests can be conducted without making two strain measurements provided that:

- a) the first five specimens are shown to fail at a bending strain less than the value given in 9.8 using back-to-back strain measurements;
- b) there is no change in the test conditions (i.e. batch, specimen type, test conditions, operator, test equipment, etc.);

c) the tests are conducted over a short time period without disrupting the fixture alignment.

In such cases, the modulus, if required, can be obtained from a single strain measurement.

The change in procedure shall be reported in the test report.

9.4 Mount the specimen in the compression fixture.

9.5 Set the cross-head speed to 1 mm/min \pm 0,5 mm/min and load the specimen to failure.

9.6 Record the load and the strain (or deformation) continuously, if possible, or at least record the data at regular increments of strain.

9.7 Record the maximum load sustained by the specimen during the test.

9.8 Check that the test was valid (see 7.2). A test is valid if failure occurs within or at the end of the specimen gauge length. There shall be no failure (breaking) of the specimen ends when loaded by method B.

Bending is acceptable if the difference between the strains recorded on each face of the specimen throughout the duration of the test until failure is such that

$$\left| \frac{\varepsilon_{11b} - \varepsilon_{11a}}{\varepsilon_{11b} + \varepsilon_{11a}} \right| \leq 0,1$$

where ε_{11a} and ε_{11b} are the longitudinal strains on opposite faces of the specimen.

If a large strain difference suggests an Euler column buckling failure, annex D can be used to calculate a revised thickness for type B specimens.

9.9 Record the mode of failure (see Figure 6).

10 Expression of results

10.1 Calculate the compressive strength σ_{cM} , expressed in megapascals, using the equation

$$\sigma_{cM} = \frac{F_{\max}}{bh}$$

where

F_{\max} is the maximum load, in newtons;

b is the width, in millimetres, of the test specimen;

h is the thickness, in millimetres, of the test specimen.

10.2 Calculate the compressive modulus E_c , expressed in megapascals, using the equation

$$E_c = \frac{\sigma_c'' - \sigma_c'}{\varepsilon_c'' - \varepsilon_c'}$$

where

σ_c'' is the compressive stress at $\varepsilon_c'' = 0,0025$, expressed in megapascals;

σ_c' is the compressive stress at $\varepsilon_c' = 0,0005$, expressed in megapascals.

See Figure 5 [N.B. $\varepsilon'_c = 0,0005$ and $\varepsilon''_c = 0,0025$ shall be average values if the strain values on opposite faces of the specimen are not equal (see 9.8)].

10.3 Calculate the compressive failure strain ε_{cM} from the mean of the longitudinal strains (ε_{11a} and ε_{11b}) at failure.

10.4 Calculate the arithmetic mean of the test results and, if required, the standard deviation and the 95 % confidence interval of the mean using the procedure given in ISO 2602.

11 Precision

The precision of this test method is not known because interlaboratory data are not available. When interlaboratory data are obtained, a precision statement will be added at the following revision.

12 Test report

The test report shall include the following information:

- a) a reference to this International Standard, indicating the loading method and specimen type used;
- b) all details necessary for complete identification of the material tested, including type, source, manufacturer's code-number, form and previous history, where these are known;
- c) all relevant information on the preparation of the test specimens, including information on the direction of cutting/testing (e.g. direction 1 or 2 in Figure 1);
- d) all details necessary for complete identification of the fixture used;
- e) the dimensions of the test specimens;
- f) the test conditions and conditioning procedures, if applicable;
- g) the number of specimens tested;
- h) the speed of testing;
- i) the accuracy grading of the test machine (see ISO 5893);
- j) the method of strain or deformation measurement;
- k) the individual test results, if required;
- l) the mean values of the individual results;
- m) the type of failure obtained;
- n) the standard deviations and the 95 % confidence intervals of the mean values, if required;
- o) the date of measurement.

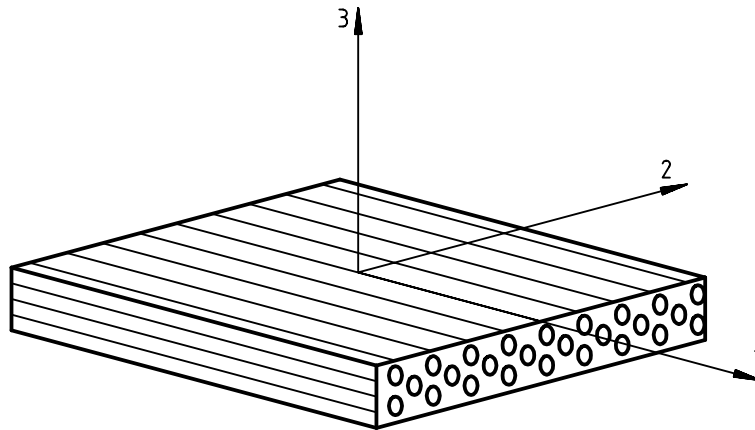
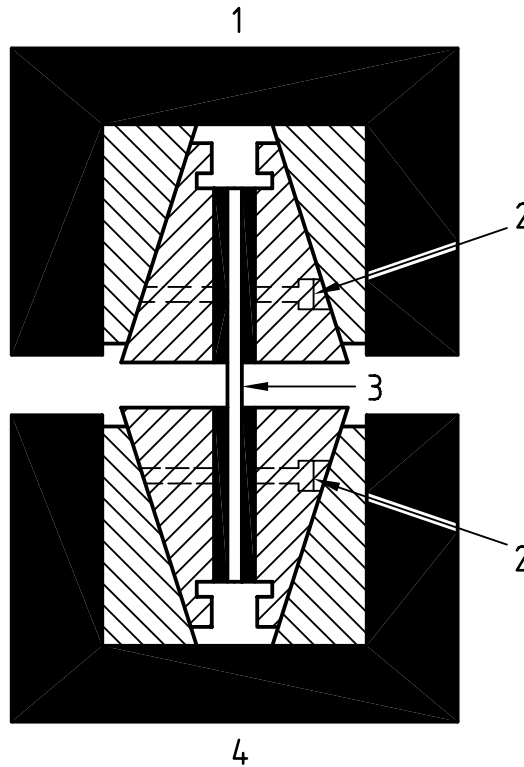

Figure 1 — Unidirectionally reinforced composite plate element showing symmetry axes



Key

- | | | | |
|---|---------------------|---|---------------------|
| 1 | Upper housing block | 3 | Specimen |
| 2 | Locking screws | 4 | Lower housing block |

Figure 2 — Schematic diagram of compression test specimen and fixture for method 1

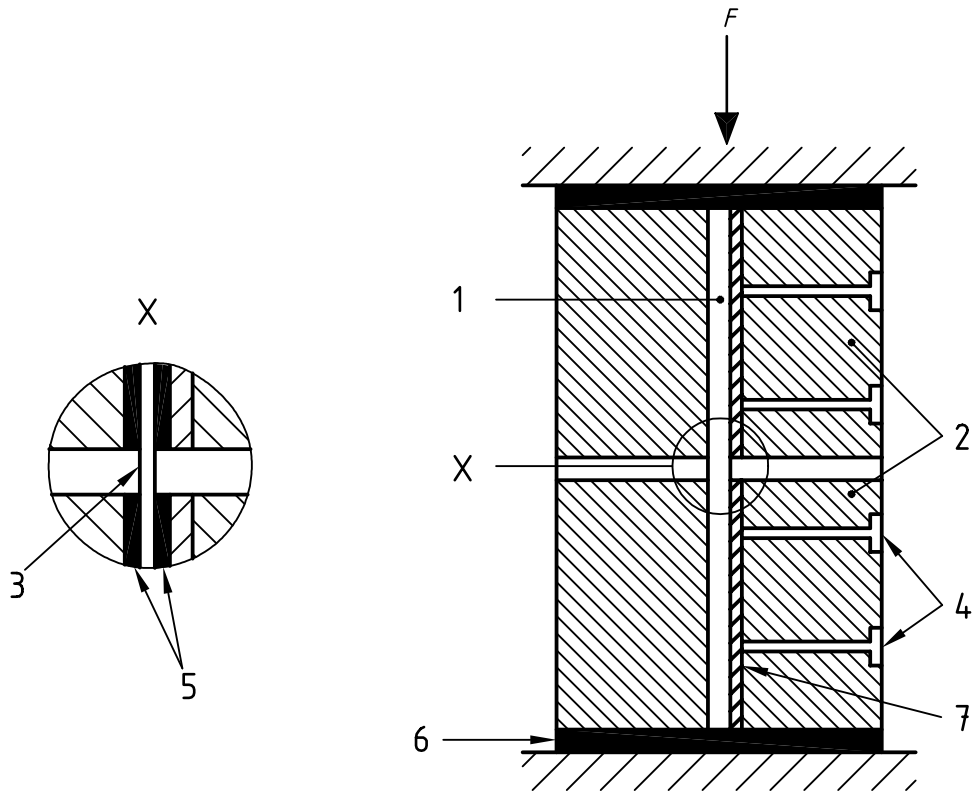

Key

- | | | | |
|---|---|---|---------------------|
| 1 | Specimen, untabbed (or tabbed — see insert) | 4 | Locking screws |
| 2 | Support blocks | 5 | Tabs |
| 3 | Specimen | 6 | End-loading plate |
| | | 7 | Moveable face plate |

Figure 3 — Schematic diagram of compression test fixture for method 2

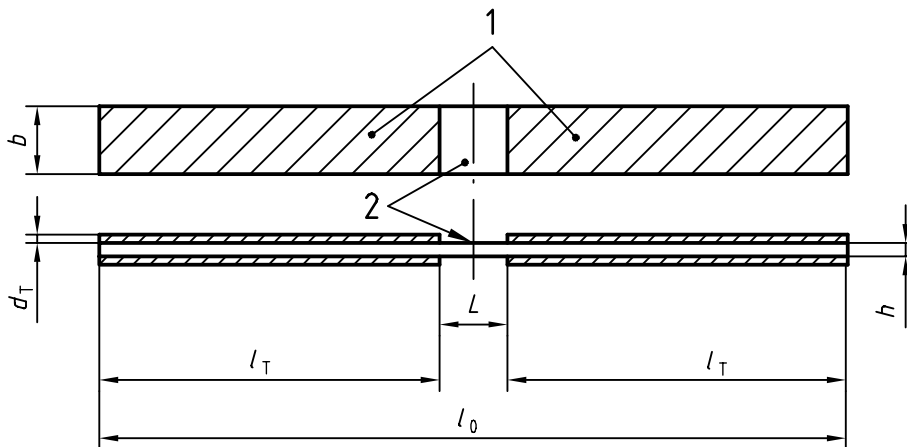

Key

- | | |
|---|----------|
| 1 | Tabs |
| 2 | Specimen |

Figure 4 — Type A and B tabbed-specimen designs (dimensions are given in Table 1)

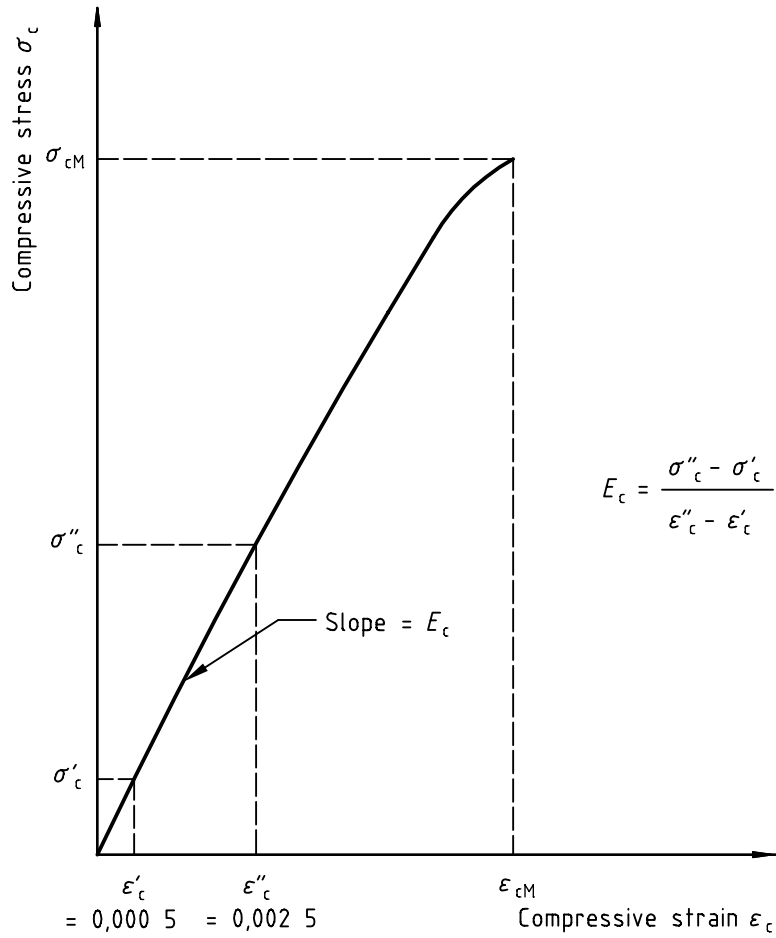

Figure 5 — Compressive stress/strain diagram

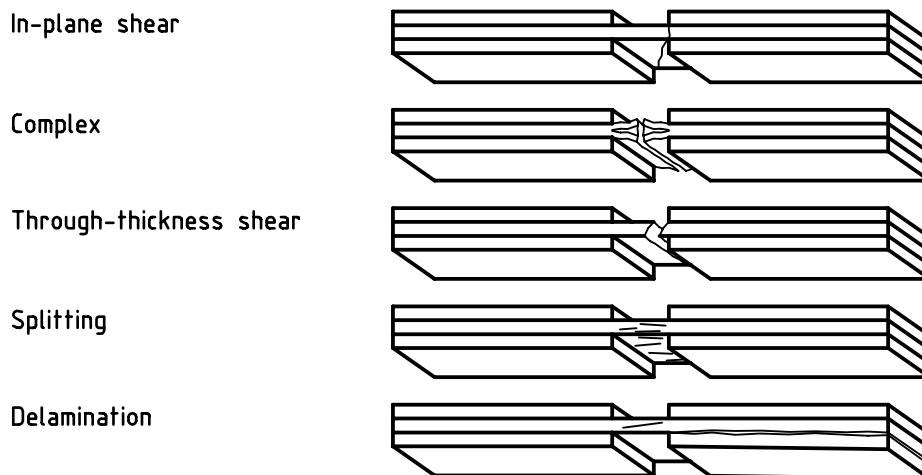

Figure 6 — Acceptable modes of failure

Annex A (normative)

Specimen preparation

A.1 Machining the specimens

In all cases, take the following precautions:

- Avoid working under conditions that would create a large build-up of heat in the specimen (the use of a coolant is recommended). If a liquid coolant is used, dry the specimens immediately after machining.
- Check that all cut surfaces of the specimen are free from machining defects.

A.2 Preparation of specimens with bonded end tabs

A recommended method is as follows:

Cut out from the material under test a sheet having the length of the intended test specimens and of a width suitable for the number of specimens required.

Identify the "1"-direction of the material in the sheet.

Cut out rectangular strips of the required length and width for the tabs.

Attach the strips to the sheet as follows:

- a) If required, rub with fine abrasive paper or lightly blast with suitable grit all the surfaces to which adhesive will be applied.
- b) Remove all dust from these surfaces and clean them with a suitable solvent.
- c) Bond the strips in place along the ends of the sheet, parallel to each other and normal to the length direction of the specimens, as shown in Figure A.1, using a high-elongation, cold-hardening adhesive (for example a two-part epoxy adhesive) and strictly following the adhesive manufacturer's instructions. Heat-curing film adhesives can also be used, provided the cure temperature is at least 40 °C below the glass transition temperature or curing temperature of the resin in the laminate, whichever is the lower.

NOTE It is recommended that a film adhesive with a thin carrier be used. The adhesive should preferably have a shear strength greater than 30 MPa. It is desirable that the adhesive used be flexible in nature, with an elongation at break greater than that of the material under test.

- d) Keep the bonded parts at the pressure and temperature recommended by the adhesive manufacturer for the time recommended by the manufacturer.
- e) Cut the sheet, together with the strips constituting the end tabs, into test specimens (see Figure A.1).

NOTE For unidirectional materials, the mean fibre axis can be determined by splitting the edge of the test panel. The direction can be confirmed every few specimens by repeating the operation. If splitting does not give a clean edge due to misalignment between plies or layers, the test panel should not be used unless it represents the results of a particular process or product.

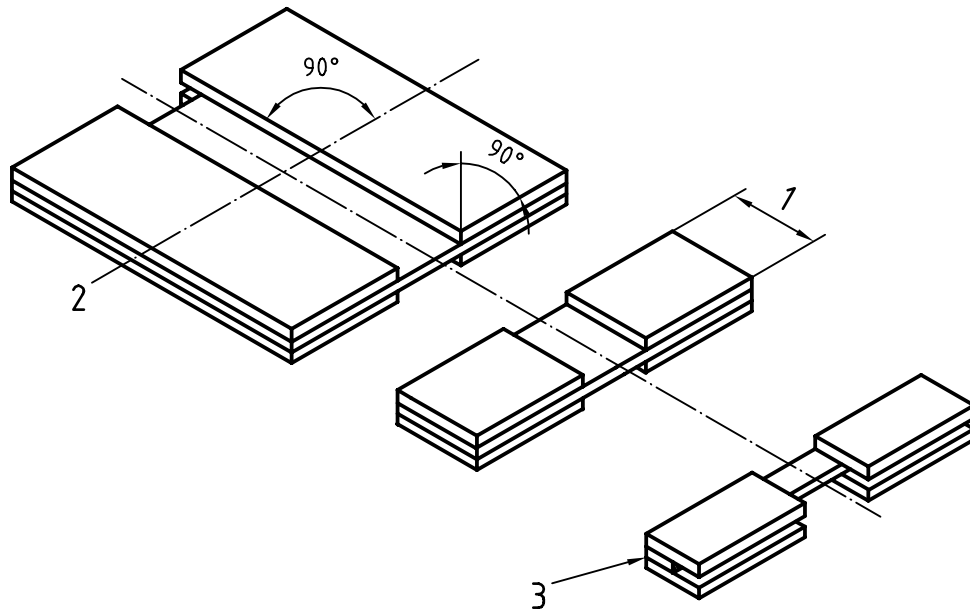
**Key**

- 1 Required width
- 2 Longitudinal direction
- 3 Trimmed to waste

Figure A.1 — Tabbed panel for specimen preparation

Annex B (informative)

Compression fixtures for method 1

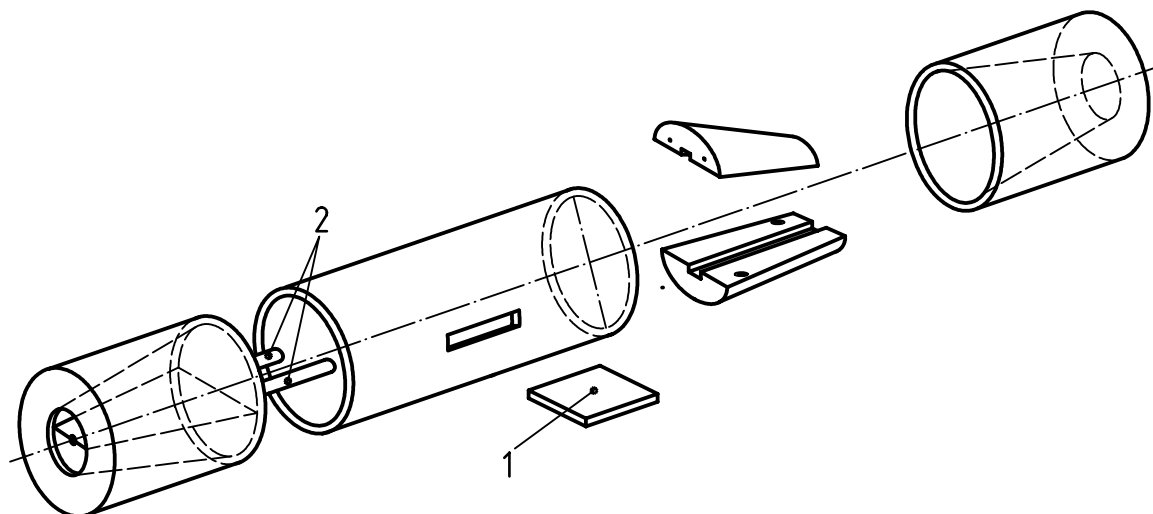

Key

- 1 Test-length spacer
- 2 Alignment pins

NOTE The overall specimen thickness (4,5 mm) and parallelism within the end fittings must be maintained within the tolerance given in ASTM D 3410 to avoid jamming of the jig.

Figure B.1 — ASTM D 3410/A (Celanese) test fixture

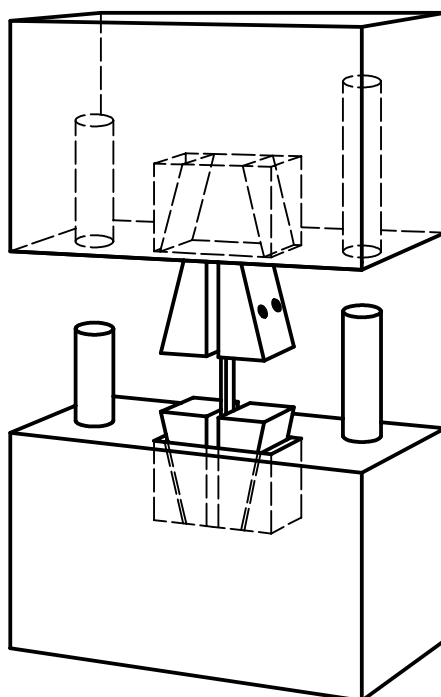
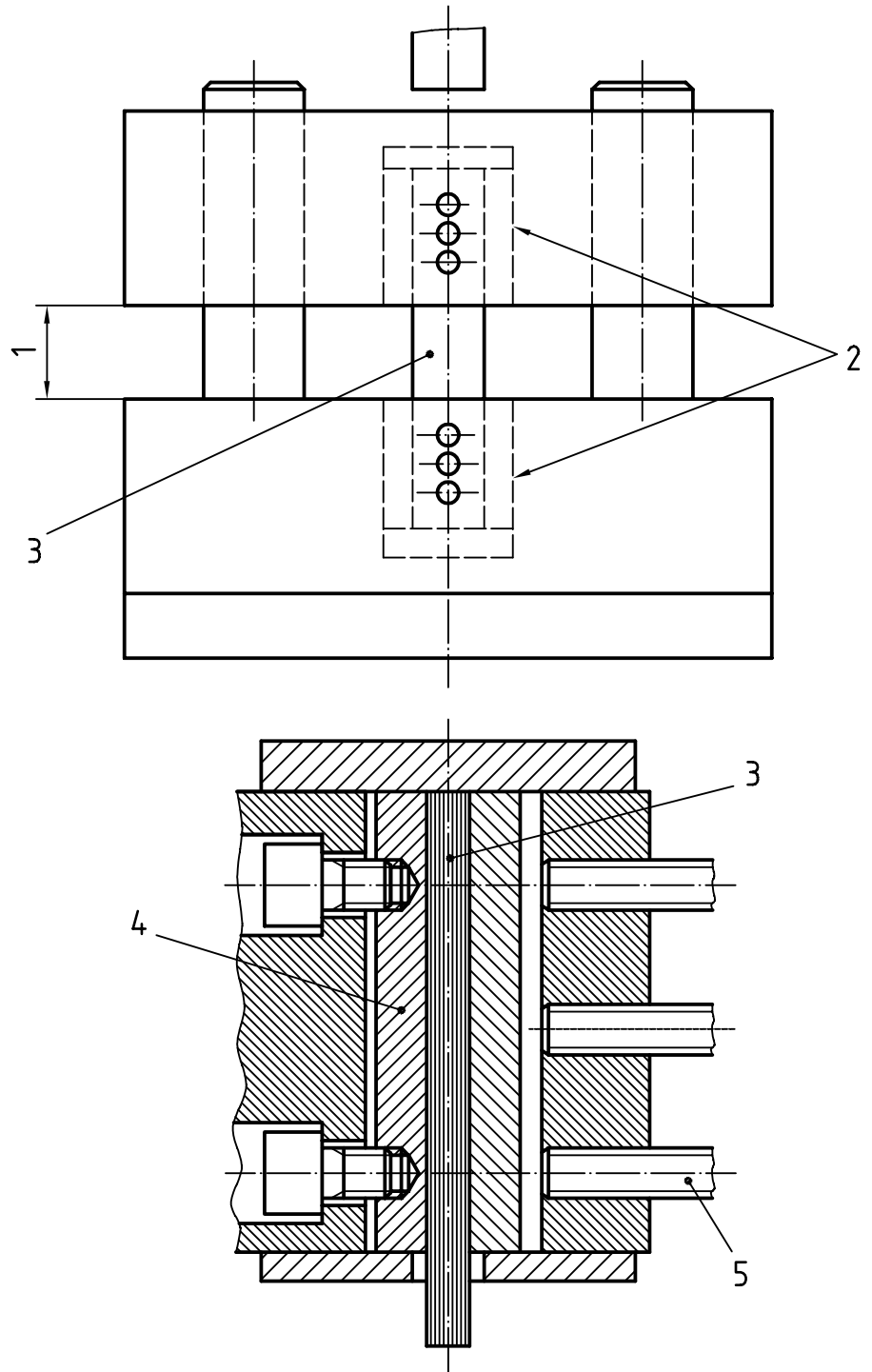

Figure B.2 — ASTM D 3410/B (ITTRI) test fixture

Annex C
(informative)

Compression fixtures for method 2



Key

- 1 Specimen test length
- 2 Housings for specimen ends
- 3 Specimen
- 4 Wedge
- 5 Locking screw

Figure C.1 — ISO 8515 end-loading fixture

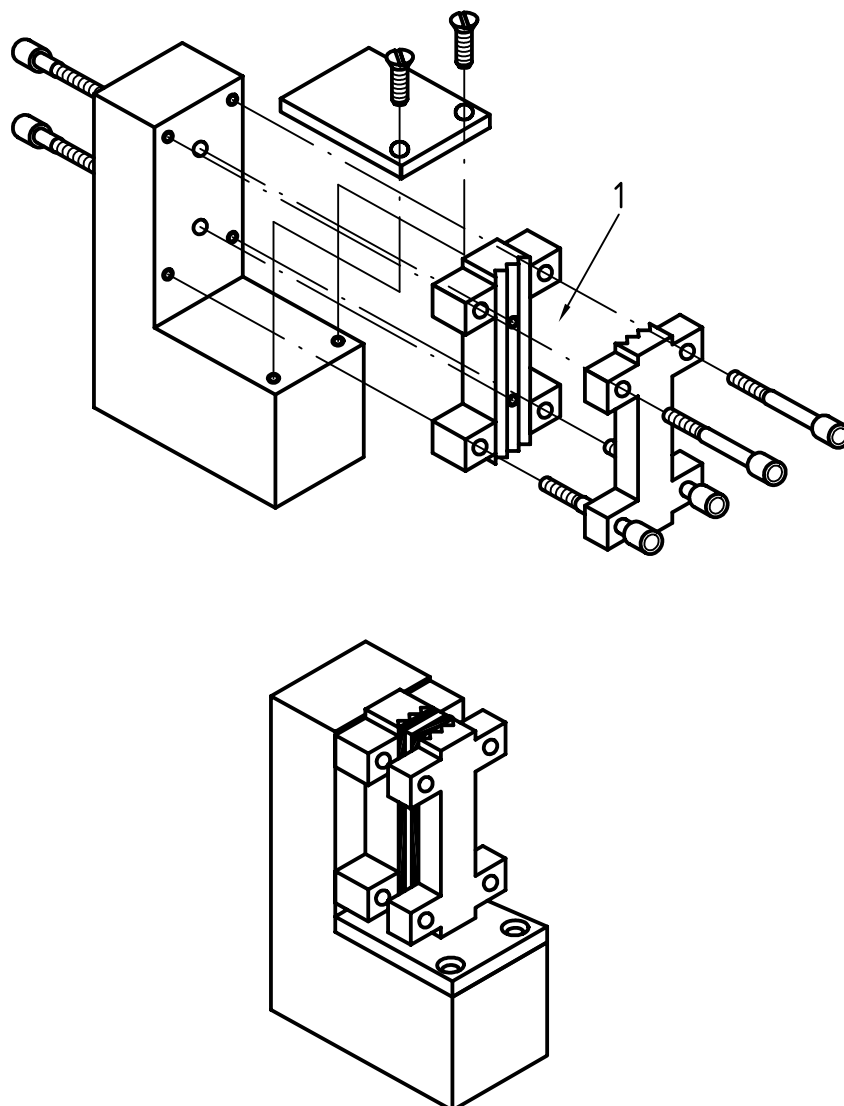

Key

1 Specimen position

NOTE Locking screws shall be loaded to 5 N·m each.

Figure C.2 — ASTM D 695 (modified) type from prEN 2850
 (this has a lower degree of specimen end support than the ISO 8515 jig)

Annex D (informative)

Euler buckling criteria

The information below, taken from ASTM D 3410, gives guidance on the criteria for avoidance of Euler column buckling. If Euler buckling is suspected from back-to-back strain measurements, then the check given below should be carried out to determine a new specimen thickness (type B specimens only).

Specimen thickness, gauge length and modulus of elasticity in combination determine the inherent stability of a compression specimen of unsupported gauge length and are related by equation (D.1). The lower the expected modulus and the higher the expected compression strength, the greater the specimen thickness that must be used in order to prevent Euler (column) buckling.

$$h \geq \frac{L}{0,9069 \sqrt{\left(1 - \frac{1,2\sigma_c}{G_{13}}\right) \left(\frac{E_c}{\sigma_c}\right)}} \quad (\text{D.1})$$

where

E_c is the compression modulus in the direction of the specimen axis, in megapascals;

σ_c is the compression strength in the direction of the specimen axis, in megapascals;

G_{13} is the through-thickness shear modulus (assumed to be 4 MPa in ASTM D 3410);

h is the specimen thickness, in millimetres;

L is the gauge length, in millimetres.

NOTE The above equation is based on the conservative assumption of pin-loaded ends and a linear elastic material response. The shear response of commonly used composites is highly non-linear, and inelastic buckling calculations even for clamped-end conditions may not always yield higher buckling loads than for the elastic pinned-end condition.

Bibliography

- [1] ASTM D 695:1996, *Standard test method for compressive properties of rigid plastics*.
- [2] ASTM D 3410/D 3410M:1995, *Standard test method for compressive properties of polymer matrix composite materials with unsupported gage section by shear loading*.
- [3] CRAG 400, *Method of test for longitudinal compression strength and modulus of unidirectional fibre reinforced plastics*, RAE TR 88012 (1988).
- [4] DIN 65380:1991, *Aerospace; fibre reinforced plastics; testing of unidirectional laminates and woven-fabric laminates; compression test*.
- [5] ISO 604:1993, *Plastics — Determination of compressive properties*.
- [6] ISO 8515:1991, *Textile-glass-reinforced plastics — Determination of compressive properties in the direction parallel to the plane of lamination* (withdrawn in 1999 following publication of this International Standard).
- [7] JIS K 7076, *Testing method for compressive properties of carbon fibre reinforced plastics*.
- [8] prEN 2850:—¹⁾, *Aerospace series — Carbon thermosetting resin, unidirectional laminates — Compression test parallel to the fibre direction*.
- [9] SACMA SRM1-88, *Compressive properties of orientated fiber-resin composites*, Suppliers of Advanced Composite Materials Association, USA.

¹⁾ To be published.

