

---

---

**Safety of machinery — Permanent  
means of access to machinery —**

**Part 3:  
Stairs, stepladders and guard-rails**

*Sécurité des machines — Moyens d'accès permanents aux  
machines —*

*Partie 3: Escaliers, échelles à marches et garde-corps*



**COPYRIGHT PROTECTED DOCUMENT**

© ISO 2016, Published in Switzerland

All rights reserved. Unless otherwise specified, no part of this publication may be reproduced or utilized otherwise in any form or by any means, electronic or mechanical, including photocopying, or posting on the internet or an intranet, without prior written permission. Permission can be requested from either ISO at the address below or ISO's member body in the country of the requester.

ISO copyright office  
Ch. de Blandonnet 8 • CP 401  
CH-1214 Vernier, Geneva, Switzerland  
Tel. +41 22 749 01 11  
Fax +41 22 749 09 47  
copyright@iso.org  
www.iso.org

# Contents

	Page
<b>Foreword</b> .....	<b>iv</b>
<b>Introduction</b> .....	<b>v</b>
<b>1 Scope</b> .....	<b>1</b>
<b>2 Normative references</b> .....	<b>1</b>
<b>3 Terms and definitions</b> .....	<b>1</b>
<b>4 General requirements</b> .....	<b>6</b>
4.1 Construction and materials .....	6
4.2 Design and construction for the structure and the steps .....	6
<b>5 Specific requirements applicable to stairs</b> .....	<b>6</b>
<b>6 Specific requirements applicable to step ladders</b> .....	<b>7</b>
<b>7 Specific requirements applicable to guard-rails</b> .....	<b>9</b>
7.1 Guard-rails for platforms, walkways and stair landings .....	9
7.2 Guard-rails and handrails for stairs and handrails for step ladders .....	11
7.3 Additional fall-protection when steps, stairs or ladders are near guard-rails of working platforms .....	13
7.4 Gates .....	13
<b>8 Verification of safety requirements</b> .....	<b>14</b>
8.1 General .....	14
8.2 Testing of guard-rails .....	14
8.2.2 Testing procedure .....	16
8.3 Testing of steps of a stair .....	17
8.4 Testing of stepladders .....	19
<b>Annex A (informative) Significant technical changes between this part of ISO 14122 and the     previous edition</b> .....	<b>20</b>
<b>Bibliography</b> .....	<b>22</b>

## Foreword

ISO (the International Organization for Standardization) is a worldwide federation of national standards bodies (ISO member bodies). The work of preparing International Standards is normally carried out through ISO technical committees. Each member body interested in a subject for which a technical committee has been established has the right to be represented on that committee. International organizations, governmental and non-governmental, in liaison with ISO, also take part in the work. ISO collaborates closely with the International Electrotechnical Commission (IEC) on all matters of electrotechnical standardization.

The procedures used to develop this document and those intended for its further maintenance are described in the ISO/IEC Directives, Part 1. In particular the different approval criteria needed for the different types of ISO documents should be noted. This document was drafted in accordance with the editorial rules of the ISO/IEC Directives, Part 2 (see [www.iso.org/directives](http://www.iso.org/directives)).

Attention is drawn to the possibility that some of the elements of this document may be the subject of patent rights. ISO shall not be held responsible for identifying any or all such patent rights. Details of any patent rights identified during the development of the document will be in the Introduction and/or on the ISO list of patent declarations received (see [www.iso.org/patents](http://www.iso.org/patents)).

Any trade name used in this document is information given for the convenience of users and does not constitute an endorsement.

For an explanation on the meaning of ISO specific terms and expressions related to conformity assessment, as well as information about ISO's adherence to the WTO principles in the Technical Barriers to Trade (TBT), see the following URL: [Foreword — Supplementary information](#).

The committee responsible for this document is ISO/TC 199, *Safety of machinery*.

This second edition cancels and replaces the first edition (ISO 14122-3:2001) which has been technically revised. It also incorporates the Amendment ISO 14122-3:2001/Amd 1:2010.

ISO 14122 consists of the following parts, under the general title *Safety of machinery — Permanent means of access to machinery*:

- *Part 1: Choice of fixed means and general requirements of access*
- *Part 2: Working platforms and walkways*
- *Part 3: Stairs, stepladders and guard-rails*
- *Part 4: Fixed ladders*

An additional part, dealing with mobile machinery, is under preparation.

## Introduction

This International Standard is a type-B standard as stated in ISO 12100. It is relevant, in particular, for the following stakeholder groups representing the market players with regard to machinery safety:

- machine manufacturers (small, medium and large enterprises);
- health and safety bodies (regulators, accident prevention organizations, market surveillance, etc.).

Others can be affected by the level of machinery safety achieved with the means of this International Standard by the above-mentioned stakeholder groups:

- machine users/employers (small, medium and large enterprises);
- machine users/employees (e.g. trade unions, organizations for peoples with special needs);
- service providers, e.g. for maintenance (small, medium and large enterprises);
- consumers (in case of machinery intended for use by consumers).

The above-mentioned stakeholder groups have been given the possibility to participate at the drafting process of this International Standard.

In addition, this International Standard is intended for standardization bodies elaborating type-C standards. The requirements of this International Standard can be supplemented or modified by a type-C standard.

For machines which are covered by the scope of a type-C standard and which have been designed and built according to the requirements of that standard, the requirements of that type-C standard take precedence.

The purpose of this International Standard is to define the general requirements for safe access to machines. ISO 14122-1 gives guidance about the correct choice of access means when the necessary access to the machine is not possible directly from the ground level or from a floor or platform.

The dimensions specified are consistent with established ergonomic data given in ISO 15534-3.



# Safety of machinery — Permanent means of access to machinery —

## Part 3: Stairs, stepladders and guard-rails

### 1 Scope

This part of ISO 14122 gives requirements for non-powered stairs, stepladders and guard-rails which are a part of a stationary machine, and to the non-powered adjustable parts (e.g. foldable, slidable) and movable parts of those fixed means of access.

NOTE 1 “Fixed” means of access are those mounted in such a manner (for example, by screws, nuts, welding) that they can only be removed by the use of tools.

This part of ISO 14122 specifies minimum requirements that also apply when the same means of access is required as the part of the building or civil construction (e.g. stairs, stepladders, guard-rails) where the machine is installed, on condition that the main function of that part of the construction is to provide a means of access to the machine.

NOTE 2 Where no local regulation or standards exists, this part of ISO 14122 may be used also for means of access which are outside the scope of the standard.

It is intended that this part of ISO 14122 be used with ISO 14122-1 to give the requirements for steps, stepladders and guard-rails.

The ISO 14122 series as a whole is applicable to both stationary and mobile machinery where fixed means of access are necessary. It is not applicable to powered means of access such as lifts, escalators, or other devices specially designed to lift persons between two levels.

This part of ISO 14122 is not applicable to machinery manufactured before the date of its publication.

### 2 Normative references

The following documents, in whole or in part, are normatively referenced in this document and are indispensable for its application. For dated references, only the edition cited applies. For undated references, the latest edition of the referenced document (including any amendments) applies.

ISO 12100, *Safety of machinery — General principles for design — Risk assessment and risk reduction*

ISO 14122-1:2016, *Safety of machinery — Permanent means of access to machinery — Part 1: Choice of fixed means and general requirements of access*

### 3 Terms and definitions

For the purposes of this document, the terms and definitions given in ISO 12100, ISO 14122-1 and the following apply.

**3.1  
stairs  
step ladders**

succession of horizontal levels — *steps* (3.1.11) and *landings* (3.1.5) — allowing passage on foot from one level to another

Note 1 to entry: Stairs/step ladders are composed of the elements shown in Figure 1 and defined in 3.1.1 to 3.1.16.

Note 2 to entry: For details on the *angle of pitch* (3.1.9) for stairs/step ladders, see ISO 14122-1:2016, 3.2 and 3.3.

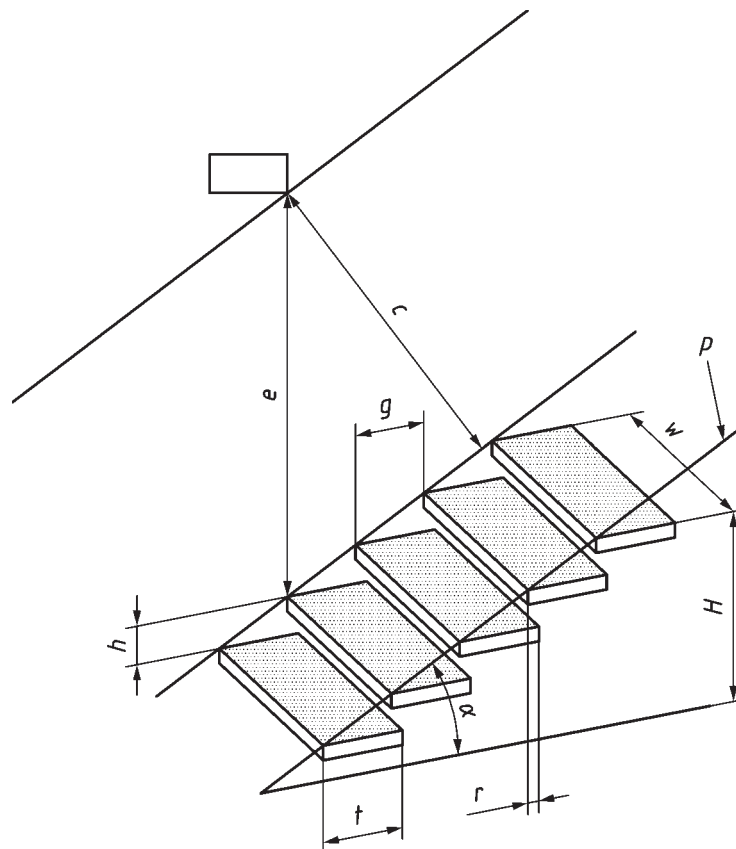

**Key**

$H$	climbing height	$\alpha$	angle of pitch
$g$	going	$w$	width
$e$	head-height	$p$	pitch line
$h$	rise	$t$	depth of step
$r$	overlap	$c$	clearance

**Figure 1 — Parts of stairs**

**3.1.1  
climbing height**

vertical distance between the reference level and the *landing* (3.1.5)

Note 1 to entry: See  $H$  in Figure 1.

**3.1.2  
flight**

uninterrupted sequence of *steps* (3.1.11) between two *landings* (3.1.5)



**3.1.3****going**

horizontal distance between the step *nosing* (3.1.12) of two consecutive steps

Note 1 to entry: See  $g$  in [Figure 1](#).

**3.1.4****head-height**

minimum vertical distance, clear of all obstacles (such as beams, ducts, etc.) above the *pitch line* (3.1.8)

Note 1 to entry: See  $e$  in [Figure 1](#).

**3.1.5****landing**

horizontal resting area situated at the end of a *flight* (3.1.2)

**3.1.6****walking line**

theoretical line indicating the average path of the users

**3.1.7****overlap**

difference between the depth of the step and the *going* (3.1.3)

Note 1 to entry: See  $r$  in [Figure 1](#).

**3.1.8****pitch line**

notional line connecting the leading edge of the *nosing* (3.1.12) of successive *steps* (3.1.11) taken on the *walking line* (3.1.6) and which extends down to the landing at the bottom of the *flight* (3.1.2) from the nosing on the landing at the top of the flight

Note 1 to entry: See  $p$  in [Figure 1](#).

**3.1.9****angle of pitch**

<stair or step ladder> angle between the *pitch line* (3.1.8) and its projection on the horizontal level

Note 1 to entry: See  $\alpha$  in [Figure 1](#).

**3.1.10****rise**

height between two consecutive *steps* (3.1.11) measured from the tread surface of one to the tread surface of the next

Note 1 to entry: See  $h$  in [Figure 1](#).

**3.1.11****step**

horizontal surface on which one places the foot to go up or down the *stair/step ladder* (3.1)

**3.1.12****nosing**

top edge at the front of the *step* (3.1.11) or *landing* (3.1.5)

**3.1.13****string**

flanking framework element supporting the *steps* (3.1.11)

**3.1.14**

**width**

clear distance over the outside faces of the *step* (3.1.11)

Note 1 to entry: See *w* in [Figure 1](#).

**3.1.15**

**depth of step**

clear distance from the leading edge or the *nosing* (3.1.12) to the rear of the *step* (3.1.11)

Note 1 to entry: See *t* in [Figure 1](#).

**3.1.16**

**clearance**

absolute minimum clear distance between any obstacle and the *pitch line* (3.1.8), measured at an angle of 90° from the pitch line

Note 1 to entry: See *c* in [Figure 1](#).

**3.2**

**guard-rail**

device for protection against accidental fall sideways with which *stairs/step ladders* (3.1) or *landings* (3.1.5), platforms and walkways may be equipped

Note 1 to entry: Typical parts of a guard-rail are shown in [Figure 2](#) and defined in 3.2.1 to 3.2.5.

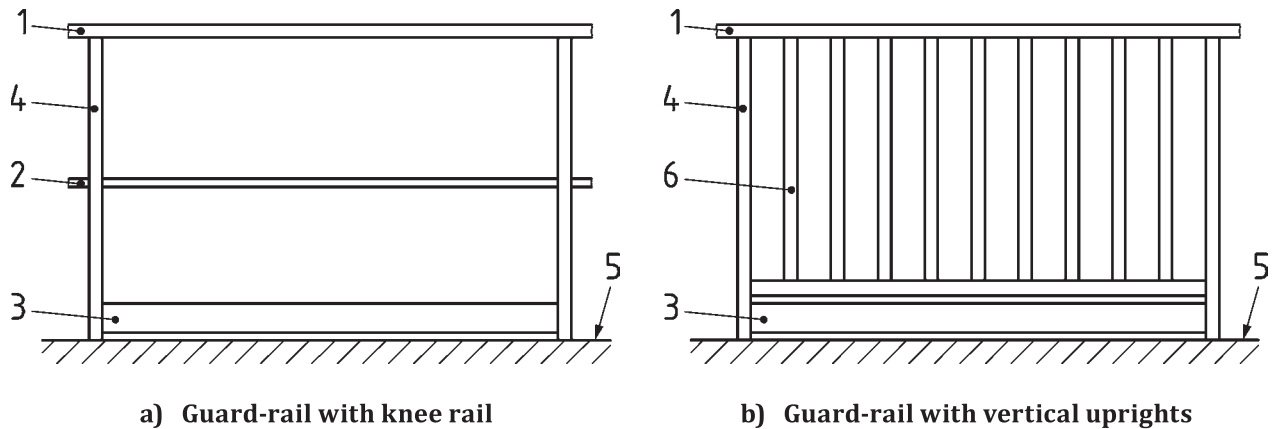

**Key**

- |   |           |   |                   |
|---|-----------|---|-------------------|
| 1 | handrail  | 4 | stanchion         |
| 2 | knee rail | 5 | walking level     |
| 3 | toe-plate | 6 | vertical uprights |

**Figure 2 — Examples of the parts of a typical structure of a guard-rail**

**3.2.1**

**handrail**

rigid top element designed to be grasped by the hand for body support which can be used individually or as the upper part of a *guard-rail* (3.2)

Note 1 to entry: See 1 in [Figure 2](#).

### 3.2.2

#### **knee rail**

rigid element of the *guard-rail* (3.2) placed parallel with the *handrail* (3.2.1), giving extra protection against the passage of a body

Note 1 to entry: See 2 in [Figure 2](#).

### 3.2.3

#### **stanchion**

vertical structural element of the *guard-rail* (3.2) to anchor the guard-rail to the platform or *stair* (3.1)

Note 1 to entry: See 4 in [Figure 2](#).

### 3.2.4

#### **toe-plate**

rigid lower part of a *guard-rail* (3.2) to prevent the falling of objects from floor level

Note 1 to entry: See 3 in [Figure 2](#).

Note 2 to entry: A toe-plate also reduces the free space between the floor and *knee rail* (3.2.2) to prevent the passage of a body.

### 3.2.5

#### **self-closing gate**

pivoting part of the *guard-rail* (3.2) which enables access through the guard-rail

Note 1 to entry: See [Figure 10](#).

Note 2 to entry: The rest position is closed.

### 3.2.6

#### **mezzanine gate**

gate designed for loading and unloading goods to and from mezzanine floor providing a permanent collective fall protection

Note 1 to entry: See [Figure 3](#).

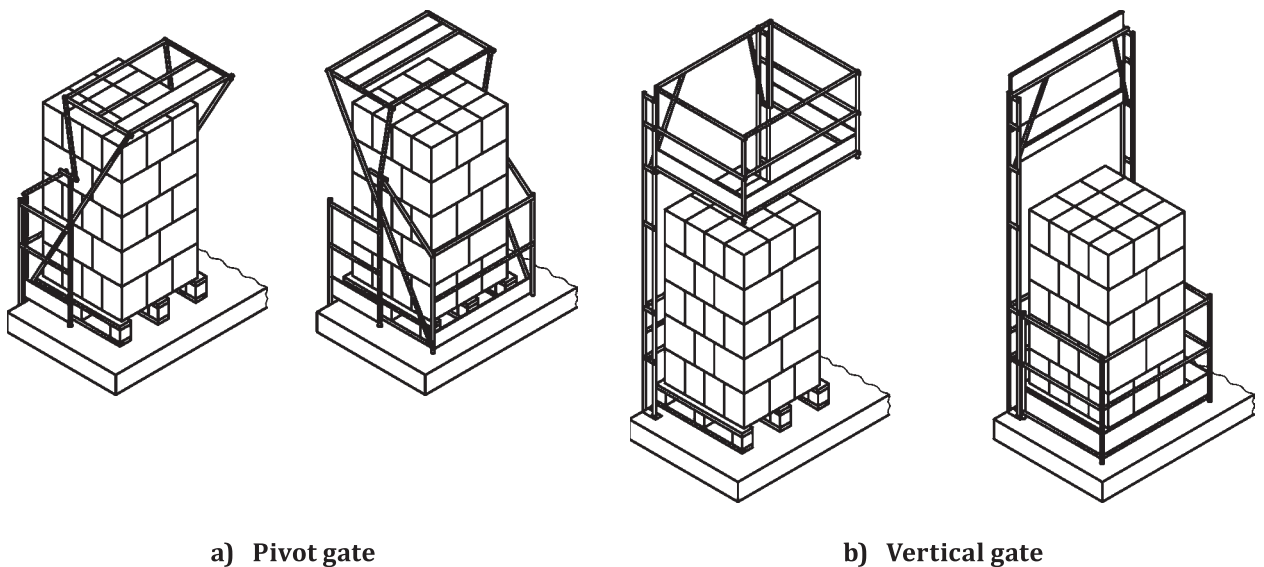

**Figure 3 — Examples of principle function of mezzanine gates**

### 3.2.7

#### transfer zone

area defined by the loading zone and the space needed for the movement of the *mezzanine gate* (3.2.6)

## 4 General requirements

### 4.1 Construction and materials

Stairs, step ladders and guard-rails — including fittings, hinges, anchorage points, supports and mountings — shall be designed and constructed and the materials selected so that they withstand the foreseeable conditions of use (see ISO 14122-1:2016, Clause 5). In particular, at least the following details shall be taken into account:

- a) dimensions of stairs, stepladders and guard-rails shall be in accordance with available anthropomorphic data (see also ISO 15534-1 and ISO 15534-3);
- b) guard-rails shall be designed and constructed to prevent objects falling;
- b) for hazards generated by falling objects through openings on steps, see ISO 14122-2:2016, 4.2.4.5.1.

Opening or closing of moving parts (gates), of adjustable parts (e.g. foldable, slidable) and of movable parts shall not cause further hazards (for example by shearing or by falling) to users and other persons in the vicinity.

### 4.2 Design and construction for the structure and the steps

**4.2.1** The structure and the steps shall be designed to satisfactorily resist the foreseeable imposed loads.

The unfactored loads applicable used for the structure of the stair or stepladder in the industrial field can vary. For each application the expected unfactored loads shall be defined. As a minimum the following assumptions for unfactored loads shall be applied in calculations to be considered, but higher values can be necessary. Higher values shall be applied when higher loading is foreseeable:

- for low density pedestrian traffic without load, 1,5 kN/m<sup>2</sup>;
- for low density pedestrian traffic with load or for high density pedestrian traffic, 5 kN/m<sup>2</sup>;

**4.2.2** Steps shall resist the following minimum unfactored loadings:

- if the clear width  $w < 1\,200$  mm then 1,5 kN shall be distributed over an area of 100 mm × 100 mm, where one boundary is the leading edge of the nosing applied at the middle of the stair width;
- if the clear width  $w \geq 1\,200$  mm then respectively two loads of each 1,5 kN shall be distributed simultaneously over each of the 100 mm × 100 mm, areas applied at the most unfavourable points spaced at intervals of 600 mm where one boundary is the leading edge of the nosing.

The deflection between the structure supporting the steps and the steps under an unfactored load shall not exceed 1/300<sup>th</sup> of the span of the step or 6 mm, whichever is the lower.

## 5 Specific requirements applicable to stairs

**5.1** Going,  $g$ , and rise,  $h$ , shall meet [Formula \(1\)](#):

$$600 \leq g + 2h \leq 660 \text{ (dimensions in millimetres)} \quad (1)$$

**5.2** The going (distance  $t$  minus  $r$ , see [Figure 4](#)) shall be between 210 mm and 310 mm.

5.3 The overlap,  $r$ , of the step shall be  $\geq 10$  mm and shall apply equally to landings and floors.

5.4 On the same flight,  $h$  shall be constant. Where it is not possible, the rise of the first step in the flight,  $h_1$ , may be reduced by maximum of 15 %.

5.5 The uppermost step shall be level with the landing (see [Figure 4](#)).

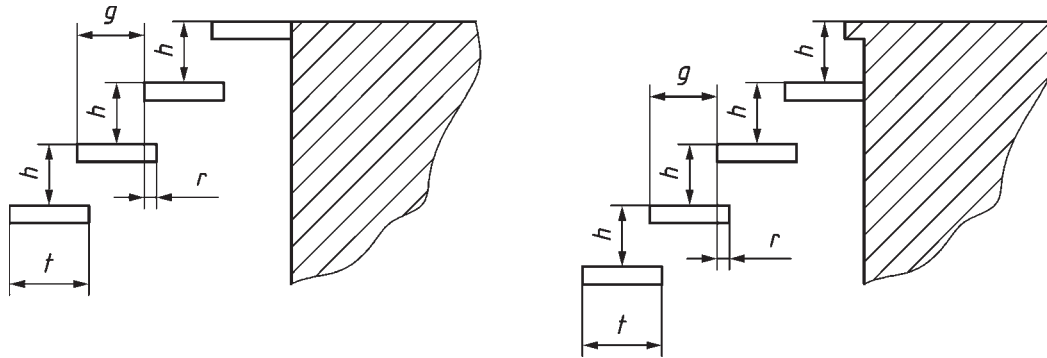

Figure 4 — Positioning of the uppermost step

5.6 Head-height,  $e$ , shall be 2 300 mm minimum (see [Figure 1](#)).

5.7 Clearance,  $c$ , shall be 1 900 mm minimum (see [Figure 1](#)).

5.8 The clear width,  $w$ , of a stair shall be a minimum of 800 mm. When the stairway is usually subject to the passage or crossing of several persons simultaneously, the clear width shall be increased to 1 000 mm. The clear width of the stair, when designated as an escape way, shall meet the requirements of appropriate regulation.

For single flights with heights less than 1 500 mm, the clear width,  $w$ , may be reduced from 600 mm to 500 mm.

Due to the design of the machine, the environment or occasional use, e.g. less than 30 days/year and less than two hours/day, the clear width,  $w$ , may be reduced from 800 mm to 600 mm. If the available space at the floor level is restricted due to pipework, electric, or constructive reason of machinery, the stair width at floor level may be reduced to 500 mm minimum, and for a maximum height of 200 mm (see ISO 14122-2:2016, Figure 1).

Any obstruction such as pipes or cable trays fitted along stairs at either head-height or finished floor level shall reduce available width to not less than 500 mm (see ISO 14122-2:2016, Figure 1).

5.9 In the case of a single straight flight (see [3.1.2](#)), the climbing height shall not exceed 4 000 mm.

In case of multiple flights, the climbing height,  $H$  (see [Figure 1](#)), of the individual stairs shall not exceed 3 000 mm and a landing is necessary before continuing on to another flight. The length of the landing shall be equal or greater than the width of the stair but at least 800 mm.

5.10 For requirements related to guard-rails for stairs, see [7.2](#).

## 6 Specific requirements applicable to step ladders

6.1 The minimum going,  $g$ , shall be 80 mm (see [Figure 5](#)).

6.2 The rises  $h_1$  and  $h_2$  shall be in accordance with [Table 1](#) (see [Figure 5](#)).

- 6.3 The overlap,  $r$ , of the step or the landing shall be  $\geq 0$  mm (see [Figure 5](#)).
- 6.4 The clear width between stringers, as well as guard-rails, shall be within the range of 500 mm to 800 mm, but preferably 600 mm.
- 6.5 On the single flight, the rise shall be constant wherever possible. In the case where it is not possible to maintain the height of the rise between the level of departure and the first step, it may be reduced by a maximum of 15 %.
- 6.6 Head-height,  $e$ , shall be 2 300 mm minimum.
- 6.7 Clearance,  $c$ , shall be 850 mm minimum.
- 6.8 The climbing height,  $H$ , of a single flight shall not exceed 3 000 mm.

For multi-flights, additional safety measures should be considered.

NOTE For the head-height ( $e$ ), clearance ( $c$ ) and climbing height ( $H$ ), see [Figure 1](#).

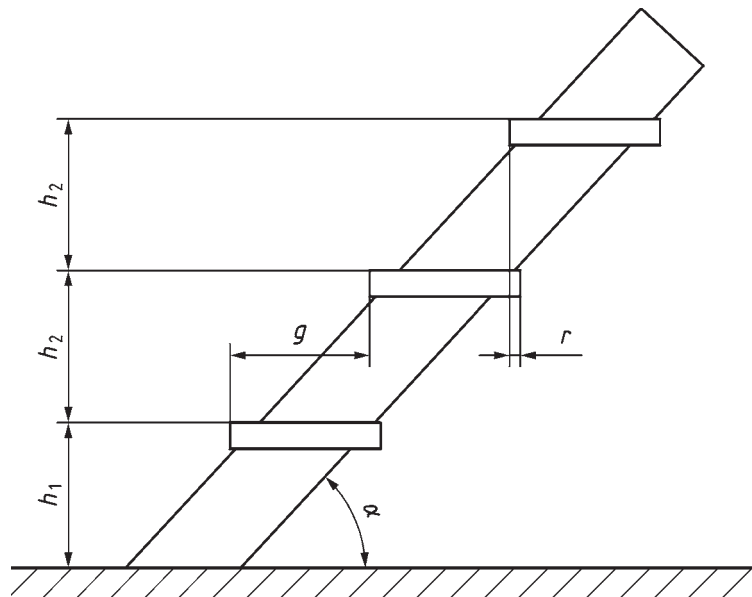

- Key**
- $g$  going
  - $h$  rise
  - $r$  overlap
  - $\alpha$  angle of pitch

**Figure 5 — Rises on a step ladder**

Dimensions in millimetres

**Table 1 — Requirements for rises**

	$45^\circ < \alpha \leq 60^\circ$		$60^\circ \leq \alpha \leq 75^\circ$	
	$h_1$	$h_2$	$h_1$	$h_2$
<b>Min.</b>	$0,5 \times h_2$	150	$0,5 \times h_2$	230
<b>Max.</b>	$h_2 + 15$	200	$h_2 + 40$	300

## 7 Specific requirements applicable to guard-rails

### 7.1 Guard-rails for platforms, walkways and stair landings

**7.1.1** When the height of the possible fall exceeds 500 mm, a guard-rail shall be installed.

**7.1.2** A guard-rail shall be provided when the gap between a platform and the structure of a machine or wall is greater than 180 mm or if the protection of the structure is not equivalent to a guard-rail (see ISO 14122-2:2016, 4.2.4.5). However, a baseboard or toe-plate shall be provided when the gap between the platform and neighbouring structure is greater than 20 mm (see ISO 14122-2:2016, 4.2.4.5).

**7.1.3** The minimum height of the guard-rail shall be 1 100 mm. The height of the handrail shall be  $\leq 1\ 100$  mm. The handrail shall be parallel to the walking line.

**7.1.4** The guard-rail shall include at least one intermediate knee rail [see [Figure 2 a\)](#)] or any other equivalent protection. The clear space between the handrail and the knee rail, as well as between the knee rail and the toe-plate, shall not exceed 500 mm.

**7.1.5** When vertical uprights are used instead of a knee rail [see [Figure 2 b\)](#)], the clear horizontal distance between those uprights shall be 180 mm maximum.

**7.1.6** A toe-plate with a minimum upstand of 100 mm shall be placed 12 mm maximum from the walking level and the edge of the platform (see [Figure 6](#)), as well as stair landings (see [Figure 7](#)). If there is a gap between the toe-plates of adjacent guard rail segments, this gap shall be not more than 20 mm.

**7.1.7** The distance between the axes of the stanchions is preferred to be limited to 1 500 mm. If this distance is exceeded, specific attention shall be paid to the stanchion anchoring strength and the fixing devices.

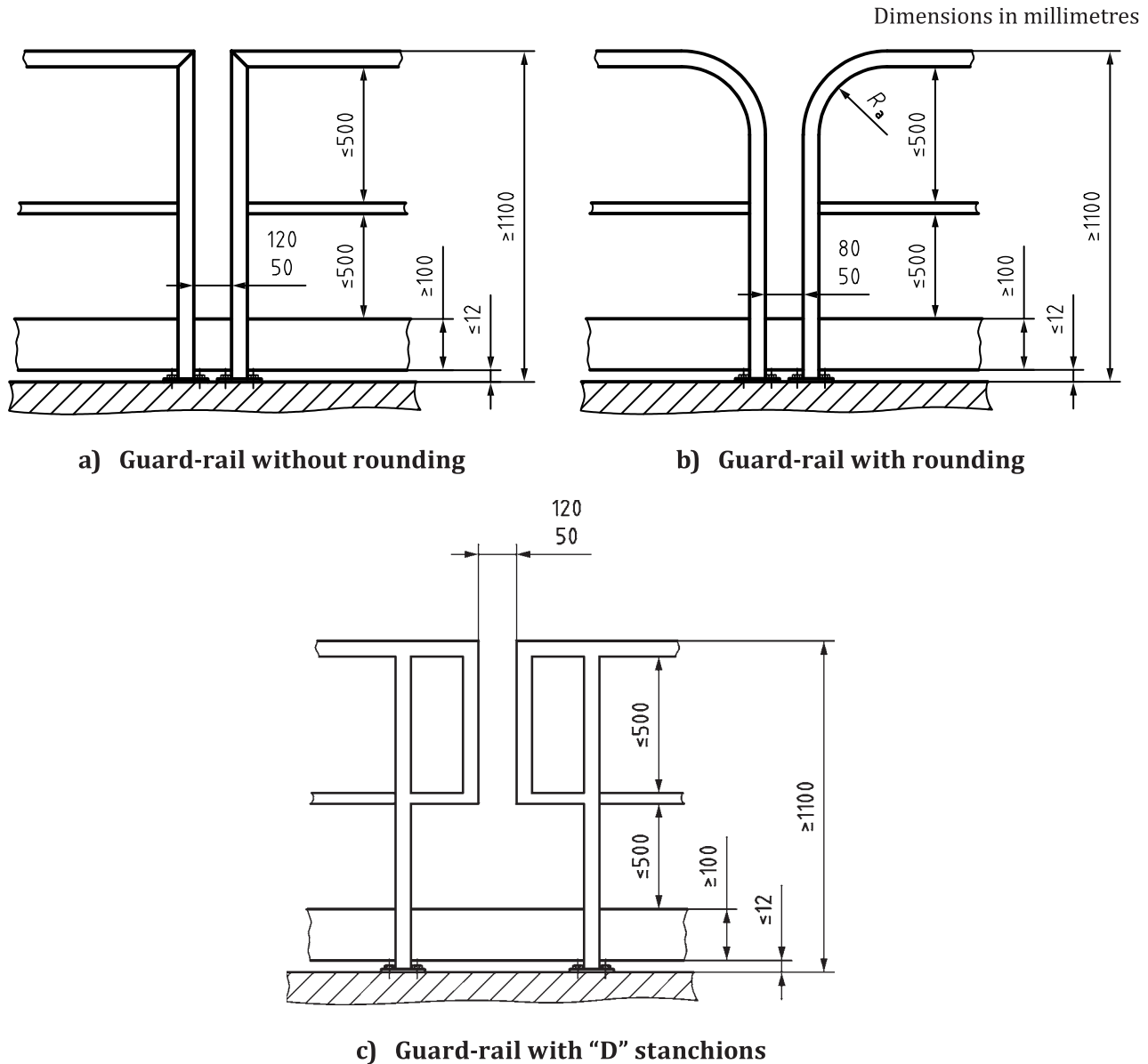

**Key**

$R_a$  radius

**Figure 6 — Clear space between two guard-rail segments**

**7.1.8** In the case of an interrupted handrail (guard-rail segments), crushing and shearing based on movement between two segments shall be avoided. If this cannot be excluded by design, the following distances to prevent hand traps and falling through shall be required:

- a) without rounding, the clear space between the two stanchions shall not be less than 50 mm and not greater than 120 mm [see [Figure 6 a](#)];
- b) with rounding, the clear space between the two stanchions shall not be less than 50 mm and not greater than 80 mm [see [Figure 6 b](#)]. The radius  $R_a$  shall be 200 mm maximum.

**7.1.9** Where access through the guard-rail is required, a gate shall be used (see [7.4](#))

**7.1.10** Ends of the handrail shall be designed so that significant hazards caused by sharp edges of the product or by catching of the user's clothing are eliminated or reduced to a minimum.



7.1.11 Fixable or foldable guard-rails shall be fitted with elements preventing unintentional opening.

## 7.2 Guard-rails and handrails for stairs and handrails for step ladders

### 7.2.1 Guard-rails and handrails for stairs

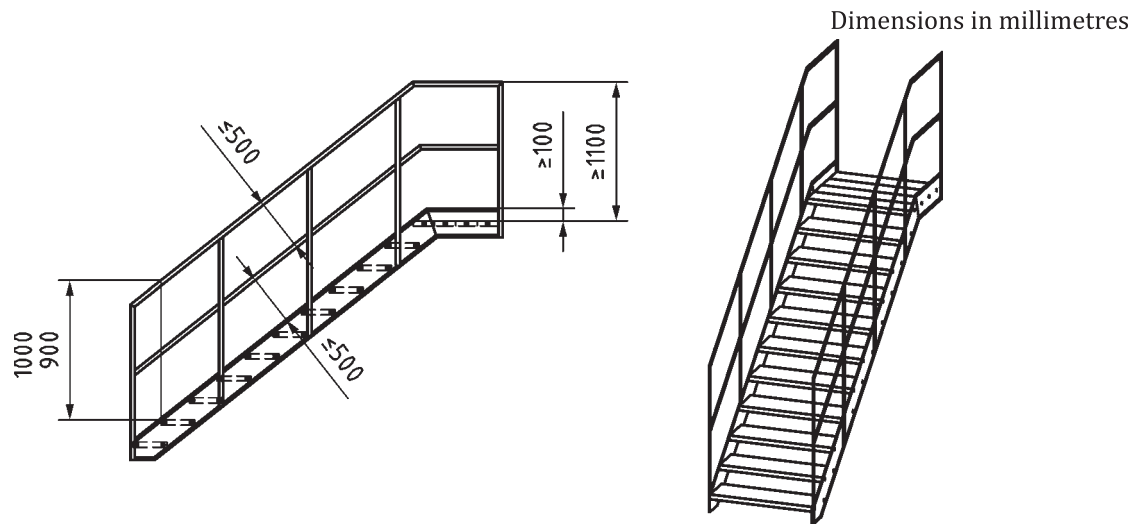

Figure 7 — Example of a stair guard-rail and its continuation to the horizontal guard-rail

7.2.1.1 A guard-rail shall be fitted whenever the height to climb exceeds 500 mm, and when there is a lateral space adjacent to the string which is greater than 120 mm, in order to provide protection on the side of the stair where this gap exists.

7.2.1.2 The space between the handrail and the stringer shall be closed at least with one knee rail or any equivalent device. The clear space between the handrail and the knee rail, as well as between the knee rail and the stringer, shall not exceed 500 mm (see [Figure 7](#)).

7.2.1.3 A stair shall have two handrails. Handrails on stairs (see [Figure 7](#)) shall be continuous. When for technical reasons this is not practicable, e.g. foldable, adjustable systems the following requirements shall apply:

- the gap between the handrails shall not be less than 50 mm and not greater than 120 mm;
- the ends of the handrail shall be designed so, that significant hazards caused by sharp edges of the product or by catching of the user's clothing are eliminated or reduced to a minimum;
- adjacent handrails shall align.

If the stairs are adjacent to a wall, or some other solid structure, and less than 1 200 mm wide, then one handrail, on the otherwise unprotected side, is permitted, provided that any gap between the stair and the wall or structure complies with [7.2.1.1](#). The handrail shall be parallel to the walking and pitch line. The handrail shall start at least vertically above the beginning of the stair. The design of the handrail shall avoid the entrapment of the clothes. Stairs shall be designed to minimize the risk of the foot slipping laterally of the step.

NOTE This can be done, for example, by stringers. In this case, additional means such as toe-plates are not required.

7.2.1.4 The vertical height of the handrail on a stair shall be between 900 mm and 1 000 mm above the nosing on the step of the flight and be a minimum of 1 100 mm above the walking level on the landing.

The shape of the handrail should have a diameter between 25 mm to 50 mm or an equivalent shape, to provide a good grip for the hand.

7.2.1.5 The length of the handrail shall be clear of obstacles within a distance of 75 mm, with the exception of the supports (see [Figure 8](#)). For distances shorter than 500 mm, the distance may be reduced to 50 mm.

Dimensions in millimetres

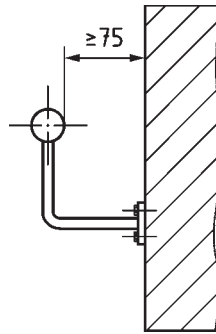

Figure 8 — Minimum gap between the handrail and any obstacle

### 7.2.2 Handrails for step ladders

7.2.2.1 Step ladders shall have two handrails. The clear width (dimension  $x$ ) between the pitch line of the step ladder to the handrail should be as shown in [Figure 9](#) and [Table 2](#).

The handrail shall commence from a maximum distance of 1 000 mm measured vertically from the bottom of the ladder (see [Figure 9](#)).

Dimensions in millimetres

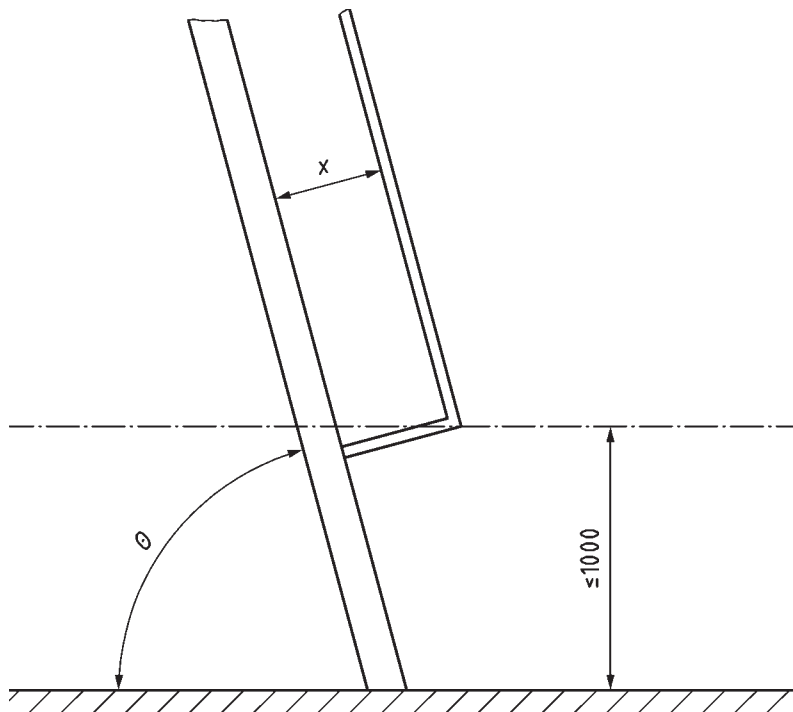

Figure 9 — Positioning of a handrail on a step ladder

**Table 2 — Example of clear width between the pitch line on a step ladder and the handrail**

$\theta$ degrees	$X$ mm
45	625
50	500
55	375
60	250
65	200
70	150
75	100

### 7.3 Additional fall-protection when steps, stairs or ladders are near guard-rails of working platforms

When additional steps, stairs or ladders are installed near guard-rails of working platforms, the height of 1 100 mm will not always be sufficient as fall protection. In this case, additional protective measures (e.g. extension of guard-rail height) are required (see ISO 14122-4:2016, Figures 16 and 17).

## 7.4 Gates

### 7.4.1 Self-closing gate

A self-closing gate shall be used for passage of persons and shall meet the requirements of the adjacent guard-rails.

Divergent to 7.1.6, a toe-plate is not required. Shear and crushing points shall be avoided. The dimensions shall be in accordance with Figure 6.

Gates shall be

- a) self-closing,

NOTE Self-closing can be achieved, for example, by spring or gravity force.

- b) held in closed position but not locked,
- c) designed to open easily onto the platform or floor, and
- d) close against a firm stop to prevent users pushing against them and falling through the opening.

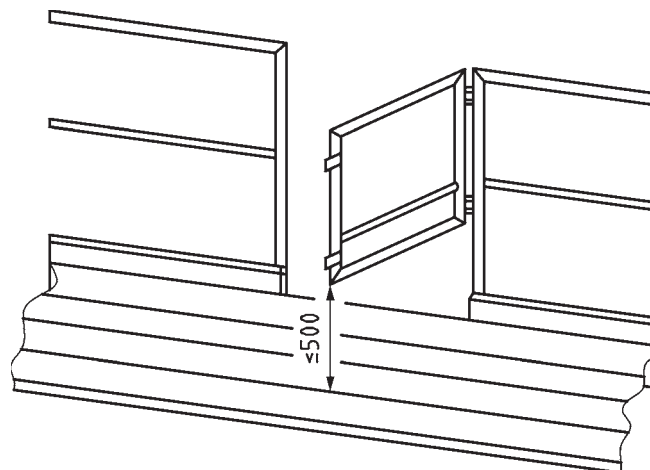

**Figure 10 — Example of self-closing gate (open onto the platform)**

### **7.4.2 Mezzanine gate**

The mezzanine gate shall comply with the requirements of [7.1](#), except [7.1.7](#) and [7.4.2](#).

In addition to the general requirement (see [Clause 4](#)), the mezzanine gate shall be designed in a manner that

- it allows the operator to place and remove the load (e.g. a pallet) without being exposed to the risk of falling,
- it allows the operator to be situated outside of any danger zone during the manual control of the gate,
- it shall not restrict the movement of the persons in the transfer zone when the gate is open and the gate on the ramp/edge is closed,
- at the transfer zone, the space between the platform and the lower edge of the gate shall have a height of less than 500 mm in the respective closed position,
- the manual operating force shall not exceed recommended force limits for machinery operation (see EN 1005-3:2002+A1:2008 and EN 1005-2:2003+A1:2008),
- the operator shall have a clear view on the transfer zone during the manual closing operation of the gate so that the risk of entrapment is minimized (see ISO 12100:2010, 6.2.2),
- it is self-closing in a stable position when released using e.g. effects of gravity,
- crushing and shearing shall be avoided during movement, in particular during manual operation at the control position, and this can be achieved when the openings are 100 mm or more (see ISO 13854),
- the vertical openings shall be less than 180 mm wide between vertical moving parts of the gate,
- the maintenance points are accessible without the risk of falling,
- a toe-plate shall be only provided on that side of the mezzanine gate where there is the risk of falling.

Depending on the design, the opposite moving gate shall have a gap of 120 mm between its lower surface and floor level to avoid crushing of feet.

## **8 Verification of safety requirements**

### **8.1 General**

The safety requirements may be verified by testing or calculation.

- a) When testing is chosen, the test procedures described in this clause shall be used.
- b) When calculation is chosen, the requirements and assumptions of this clause shall be taken into account so that strength verification of both methods is comparable.

### **8.2 Testing of guard-rails**

#### **8.2.1 General**

The testing is carried out at a guard-rail element with three stanchions, hand- and knee rail, which is mounted on the walkway.

All loads ( $F$ ) are concentrated loads based on a minimum service load of 300 N/m in accordance with [8.2.1.1](#) or [8.2.1.2](#). The load shall be applied horizontally without introducing dynamic loading, first at the level of the centre of the handrail at the middle stanchion (Position 1, [Figure 11](#)). In the second

test, the load shall be applied at the centre of the handrail at the least favourable point between two stanchions (Position 2, [Figure 12](#)).

The deflections,  $f_1$  and  $f_2$ , are measured at the centre line of the handrail by a deflection gauge. In the first test, deflection  $f_1$  is measured horizontally at position "L" (see [Figure 11](#)); in the second test, deflection  $f_2$  is measured at position "I" (see [Figure 12](#)).

## 8.2.2 Loads

### 8.2.1.1 Load for verification of usability

The load for verification of usability is represented by [Formula \(2\)](#):

$$F_U = 300 \text{ N/m} \times L \quad (2)$$

### 8.2.1.2 Load for verification of strength

The load for verification of strength is represented by [Formula \(3\)](#):

$$F_S = \gamma \times F_U \quad (3)$$

where the material factor  $\gamma = 1,75$  for steel and aluminium is derived using [Formula \(4\)](#):

$$F_S = 525 \text{ N/m} \times L \quad (4)$$

NOTE When using other materials, e.g. GRP (glass-reinforced plastic), higher values and impact testing might be required.

### 8.2.1.3 Preload

The preload is represented by [Formula \(5\)](#):

$$F_P = 75 \text{ N/m} \times L \quad (5)$$

8.2.2 Testing procedure

8.2.2.1 Testing at Position 1

To avoid setting effects, the preload,  $F_p$ , is applied to the handrail in Position 1, as shown in [Figure 11](#), for 1 min. After removing the load, the dial has to be reset to zero.

The load,  $F_U$ , shall be applied in Position 1 the same way. The deflection during the application of the load shall not exceed 30 mm.

After measuring the deflection, the load shall be increased to  $F_S$ . Apply  $F_S$  for one minute. After removing the load, the permanent deflection shall not exceed 0,3 % of the height,  $H$ .

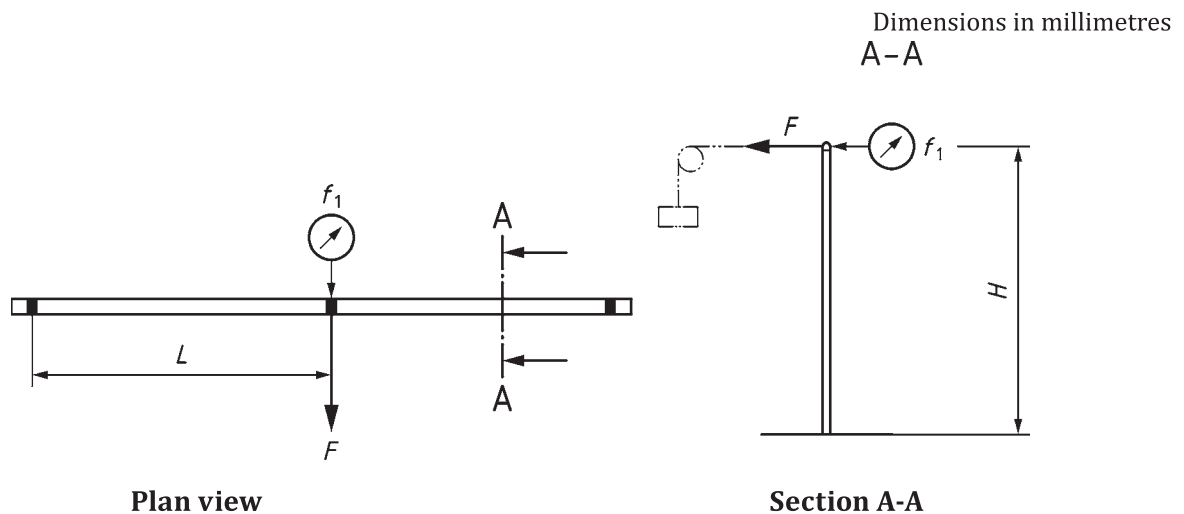

**Key**

- $f_1$  Deflection
- $L$  maximum distance between two stanchions
- $F$  Force
- $H$  height of the handrail

**Figure 11 — Stanchion measurement**

8.2.2.2 Testing at Position 2

To avoid setting effects, the preload,  $F_p$ , shall be applied to the guard-rail in Position 2, as shown in [Figure 12](#), for one minute. After removing the load, the dial has to be reset to zero.

The load,  $F_U$ , shall be applied in Position 1 the same way. The deflection during the loading shall not exceed 30 mm.

After measuring the deflection, the load shall be increased to  $F_S$ . Hold  $F_S$  for one minute. After removing the load, the permanent deflection shall not exceed 0,3 % of the distance,  $L$ .

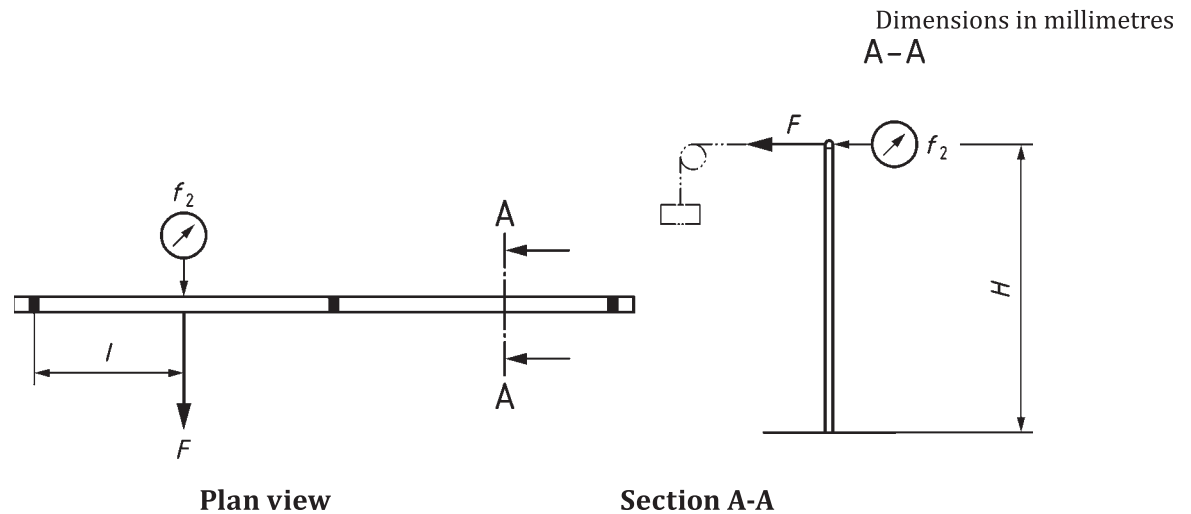
**Key**

- $f_2$  deflection  
 $l$  distance from stanchion to least favourable point<sup>a</sup>  
 $F$  force  
 $H$  height of the handrail  
<sup>a</sup> In general at  $L/2$ . For  $L$ , see [Figure 11](#).

**Figure 12 — Handrail measurement****8.3 Testing of steps of a stair****8.3.1 General**

To verify the requirements given in [4.2](#), a test shall be carried out to measure the deflection on individual steps of a stair.

The test (see [Figure 13](#)) shall be carried out on part of the stair comprising at least two steps.

Fix the sample to the ground and supporting wall (e.g. with a block, see [Figure 13](#)) so that there is no movement of the sample structure during testing.

Depending on the width (clear width,  $w$ , between the stringers and the supporting structure), the test is carried out with one test load (see [Figure 14](#)) or two test loads (see [Figure 15](#)).

The loads shall be applied to a rigid block (underlayment) with maximum dimensions of 100 mm × 100 mm and having no sharp edges.

The test load is represented by [Formula \(6\)](#):

$$F_S = \gamma \times F_d \quad (6)$$

where the minimum design load,  $F_d$ , is 1,5 kN and the material factor  $\gamma = 1,75$  for steel and aluminium.

To avoid measurement errors caused by setting effects, the tested part of a stair should be loaded first by a preload,  $F_P = 0,25 \times F_S$ .

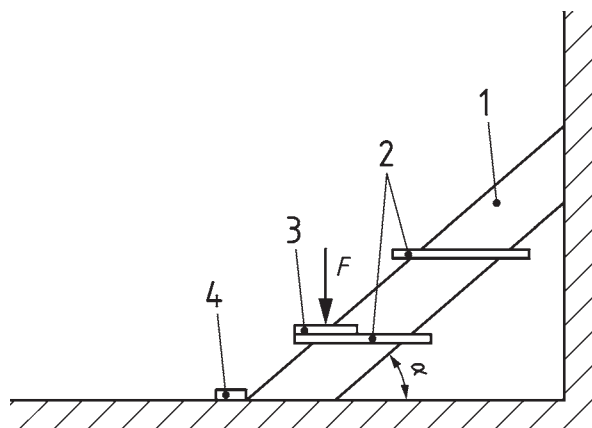

**Key**

- 1 stringer
- 2 step
- 3 rigid block for distribution the load (underlayment)
- 4 block for fixing
- $F$  preload, test-load
- $\alpha$  angle of the stair

**Figure 13 — Test sample — Principle**

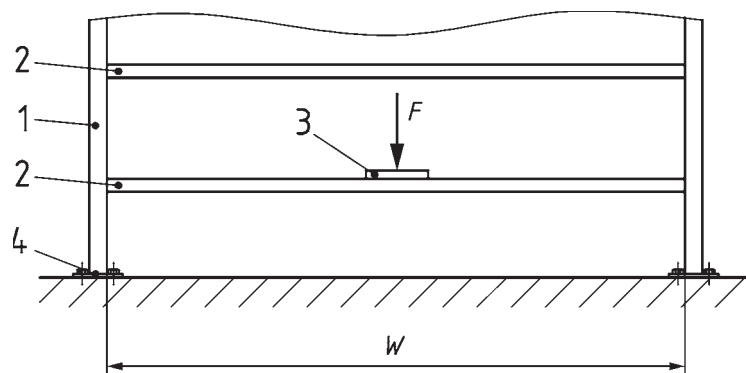

**Key**

- 1 stringer
- 2 step
- 3 rigid block for distribution the load (underlayment)
- 4 block for fixing
- $F$  preload, test-load
- $w$  clear width

**Figure 14 — Test sample for  $w < 1\ 200$  mm**

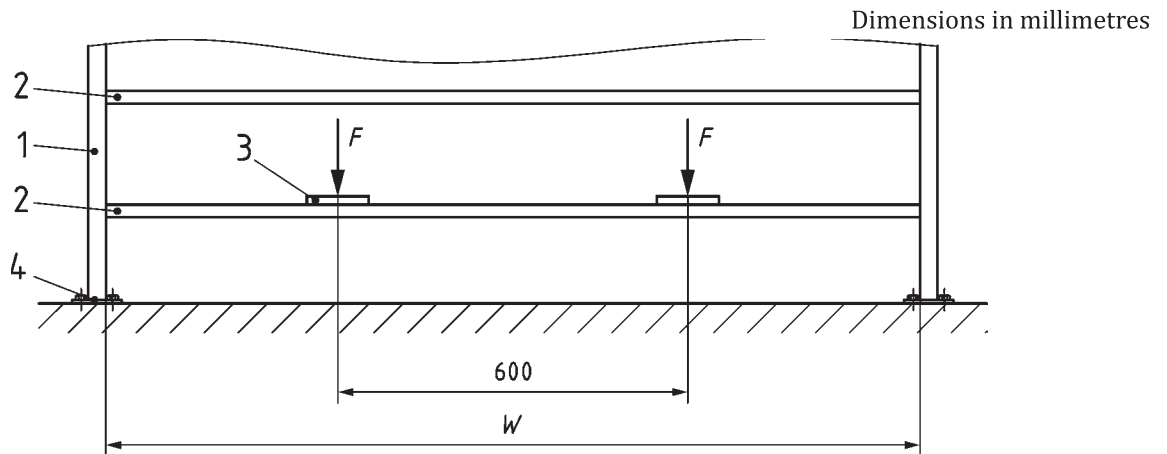

**Key**

- 1 stringer
- 2 step
- 3 rigid block for distribution the load (underlayment)
- 4 block for fixing
- $F$  preload, test-load
- $w$  clear width

**Figure 15 — Test sample for  $w \geq 1\,200$  mm**

**8.3.2 Testing procedure**

Place the rigid 100 mm × 100 mm block(s) 600 mm apart at the most unfavourable point/points on the step in accordance with [Figure 13](#), [Figure 14](#) and [Figure 15](#).

Slowly apply the preload(s),  $F_P$ , on the rigid block(s) and hold the loads for at least one minute. After removing the load, the dial of the measuring device shall be reset to zero.

Then test load(s),  $F_S$ , shall be applied slowly and hold at position for at least one minute. After removing the load, the permanent deflection shall not exceed 0,3 % of the span or 6 mm.

**8.4 Testing of stepladders**

For testing, EN 131-2 can be used as a source of knowledge.

## Annex A (informative)

### Significant technical changes between this part of ISO 14122 and the previous edition

See [Table A.1](#).

**Table A.1 — Technical changes**

ISO 14122-3	ISO 14122-3:2001 ISO 14122-3:2001/Amd1:2010
Modified: This part is limited only to “stationary machinery”, is applicable on “non-powered adjustable parts”	1 Scope
Updated	2 Normative references
<a href="#">Figure 1</a> modified	3.1
Definition modified and <a href="#">Figure 2 b</a> ) “Guard-rail with vertical uprights” added	3.2
<a href="#">3.1.4</a> , changed to “head-height”	3 Terms and definitions
Added terms <a href="#">3.2.6</a> , “mezzanine gate” <a href="#">3.2.7</a> , “transfer zone”	
Updated <a href="#">4.1</a>	
Moved to ISO 14122-1, Clause 6	4.1
Moved to ISO 14122-1, Clause 6	4.2
Moved to ISO 14122-1, Clause 6	4.3
Moved to ISO 14122-1, Clause 6	4.4
<a href="#">4.1</a>	4.5
Moved to ISO 14122-1, Clause 6	4.6
<a href="#">4.2</a>	4.7
<a href="#">4.2.1</a> , modified:	4.7.1
<a href="#">4.2.2</a>	4.7.2
New:	—
<a href="#">5.2</a>	—
<a href="#">5.3</a>	5.2
<a href="#">5.4</a> , modified; “mobile machines” deleted in the third sentence	5.3
<a href="#">5.5</a>	5.4
<a href="#">5.6</a>	5.5
<a href="#">5.7</a>	5.6
<a href="#">5.8</a> , modified requirements	5.7
<a href="#">5.9</a>	5.8
<a href="#">5.10</a>	5.9
<a href="#">Clause 6</a> , <a href="#">Figure 5</a> , “Rises on a step ladder” and <a href="#">Table 1</a> , “Requirement for rises” added	—
<a href="#">6.1</a> , changed “step depth” to “going”	6.1
<a href="#">6.2</a> , modified reference on new figure and table	6.2

Table A.1 (continued)

ISO 14122-3	ISO 14122-3:2001 ISO 14122-3:2001/Amd1:2010
<a href="#">6.3</a> , changed value for overlap from “ $\geq 10$ ” to “ $\geq 0$ ”	6.3
<a href="#">6.4</a> , clear width changed from “450 mm” to “500 mm”	6.4
<a href="#">6.5</a> , deleted “mobile machines” in the third sentence	6.5
<a href="#">7.1</a> “Guard rails for platforms, walkways and stair landings”	7.1
<a href="#">7.1.1</a>	7.1.2
<a href="#">7.1.2</a> , modified gap from “200 mm” to “180 mm” and “30 mm” to “20 mm”	7.1.3
<a href="#">7.1.3</a> , modified “requirements on handrails”	7.1.4
<a href="#">7.1.4</a>	7.1.5
<a href="#">7.1.5</a>	7.1.6
<a href="#">7.1.6</a> , modified “distance from 10 mm to 12 mm extended” and “gap between the toe-plates of adjacent guard rail segments max. 20 mm”	7.1.7
<a href="#">7.1.7</a> , <a href="#">Figure 6 b</a> ), Guard-rail with rounding added	7.1, Figure 4, 7.1.8
<a href="#">7.1.8</a> , modified “requirements on guard-rails with rounding”	7.1.9
<a href="#">7.1.9</a> , requirements on “self-closing gate” moved to <a href="#">7.4</a> “Gates”	7.1.10
<a href="#">7.1.10</a>	7.1.11
New subclause <a href="#">7.1.11</a>	—
<a href="#">7.2</a> “Guard- and handrails for stairs and stepladders”	
<a href="#">7.2.1</a> “Guard- and handrails for stairs”	7.2
<a href="#">7.2.2</a> “Handrails for stepladders”	
<a href="#">7.2.1</a> , figure modified	7.2.1
<a href="#">7.2.1.1</a> , “maximum gap from 200 mm to 120 mm reduced” and further detailed requirements on technical reason	7.2.2
<a href="#">7.2.1.2</a>	7.2.5
<a href="#">7.2.1.3</a> , modified	7.2.1
<a href="#">7.2.1.4</a> , modified	7.2.3
<a href="#">7.2.1.5</a> , modified “distance reduced from 100 mm to 75 mm” and “for short distances to 50 mm”	7.2.6
<a href="#">7.2.2</a> , <a href="#">Table 2</a> extended	7.2.4
New subclause “ <a href="#">7.3</a> Fall protection by using additional steps, stairs or ladders on working platforms”	—
New subclause “ <a href="#">7.4</a> Gates”	7.1.10
Includes “ <a href="#">7.4.1</a> , Self-closing gate” and “ <a href="#">7.4.2</a> , Mezzanine gate”	
<a href="#">Clause 8</a> , completely modified	8, 7.3
Deleted	9, 10
NOTE This list includes the significant technical changes but is not an exhaustive list of all modifications from the previous version.	

## Bibliography

- [1] EN 131-2, *Ladders — Part 2: Requirements, testing, marking*
- [2] EN 353-1, *Personal protective equipment against falls from a height — Part 1: Guided type fall arresters including a rigid anchor line*
- [3] EN 364, *Personal protective equipment against falls from a height; test methods*
- [4] EN 795, *Personal fall protection equipment — Anchor devices*
- [5] EN 1005-2:2003+A1:2008, *Safety of machinery — Human physical performance — Part 2: Manual handling of machinery and component parts of machinery*
- [6] EN 1005-3:2002+A1:2008, *Safety of machinery — Human physical performance — Part 2: Manual handling of machinery and component parts of machinery*
- [7] ISO 2867, *Earth-moving machinery — Access systems*
- [8] ISO 4254-1, *Agricultural machinery — Safety — Part 1: General requirements*
- [9] ISO 13854, *Safety of machinery — Minimum gaps to avoid crushing of parts of the human body*
- [10] ISO 13857, *Safety of machinery — Safety distances to prevent hazard zones being reached by upper and lower limbs*
- [11] ISO 14122-2, *Safety of machinery — Permanent means of access to machinery — Part 2: Working platforms and walkways*
- [12] ISO 14122-4, *Safety of machinery — Permanent means of access to machinery — Part 4: Fixed ladders*
- [13] ISO 15534-1, *Ergonomic design for the safety of machinery — Part 1: Principles for determining the dimensions required for openings for whole-body access into machinery*
- [14] ISO 15534-2, *Ergonomic design for the safety of machinery — Part 2: Principles for determining the dimensions required for access openings*
- [15] ISO 15534-3, *Ergonomic design for the safety of machinery — Part 3: Anthropometric data*



