

INTERNATIONAL STANDARD

ISO 13955

First edition
1997-12-15

Plastics pipes and fittings — Crushing decohesion test for polyethylene (PE) electrofusion assemblies

*Tubes et raccords en matières plastiques — Essai de décohésion par
écrasement des assemblages électrosoudables en polyéthylène (PE)*

This material is reproduced from ISO documents under International Organization for Standardization (ISO) Copyright License number IHS/ICC/1996. Not for resale. No part of these ISO documents may be reproduced in any form, electronic retrieval system or otherwise, except as allowed in the copyright law of the country of use, or with the prior written consent of ISO (Case postale 56, 1211 Geneva 20, Switzerland, Fax +41 22 734 10 79), IHS or the ISO Licensor's members.



Reference number
ISO 13955:1997(E)

ISO 13955:1997(E)**Foreword**

ISO (the International Organization for Standardization) is a worldwide federation of national standards bodies (ISO member bodies). The work of preparing International Standards is normally carried out through ISO technical committees. Each member body interested in a subject for which a technical committee has been established has the right to be represented on that committee. International organizations, governmental and non-governmental, in liaison with ISO, also take part in the work. ISO collaborates closely with the International Electrotechnical Commission (IEC) on all matters of electrotechnical standardization.

Draft International Standards adopted by the technical committees are circulated to the member bodies for voting. Publication as an International Standard requires approval by at least 75 % of the member bodies casting a vote.

International Standard ISO 13955 was prepared by Technical Committee ISO/TC 138, *Plastics pipes, fittings and valves for the transport of fluids*, Subcommittee SC 5, *General properties of pipes, fittings and valves of plastic materials and their accessories — Test methods and basic specifications*.

© ISO 1997

All rights reserved. Unless otherwise specified, no part of this publication may be reproduced or utilized in any form or by any means, electronic or mechanical, including photocopying and microfilm, without permission in writing from the publisher.

International Organization for Standardization
Case postale 56 • CH-1211 Genève 20 • Switzerland
Internet central@iso.ch
X.400 c=ch; a=400net; p=iso; o=isocs; s=central

Printed in Switzerland

Plastics pipes and fittings — Crushing decohesion test for polyethylene (PE) electrofusion assemblies

1 Scope

This International Standard describes a crushing test method for determining the decohesive resistance of polyethylene (PE) pipe and electrofusion socket or saddle assemblies for use in the distribution of fluids. The method is applicable to assemblies with pipes of nominal outside diameter between 16 mm and 225 mm.

2 Normative reference

The following standard contains provisions which, through reference in this text, constitute provisions of this International Standard. At the time of the publication, the edition indicated was valid. All standards are subject to revision, and parties to agreements based on this International Standard are encouraged to investigate the possibility of applying the most recent edition of the standard indicated below. Members of IEC and ISO maintain registers of currently valid International Standards.

ISO 11413:1996, *Plastics pipes and fittings — Preparation of test piece assemblies between a polyethylene (PE) pipe and an electrofusion fitting.*

3 Principle

The purpose of the test is to assess the cohesion of a PE pipe/electrofusion socket or saddle assembly by crushing a test piece. The test is conducted at $23\text{ °C} \pm 2\text{ °C}$.

The decohesive strength of the assembly is characterized by the nature of the failure in the plane of the fused material and by the percentage decohesion. The appearance and location of the failure is taken into account in assessing the strength of the assembly.

4 Apparatus

The apparatus shall include the following main elements:

4.1 Compression-testing machine, capable of a constant compression speed of $100\text{ mm/min} \pm 10\%$.

4.2 Lever, e.g. a screwdriver.

4.3 Stops, to limit the minimum separation of the platens of the compression-testing machine to twice the thickness of the pipe wall.

5 Test pieces

5.1 Sampling

Test pieces (see 5.2 and 5.3) shall be prepared from pipes and/or fittings obtained by sampling as specified in the product standard.

5.2 Preparation

5.2.1 General

Each test piece shall consist of a sector cut from an assembly comprising one or more PE pipes and a PE socket or saddle, the assembly being prepared in accordance with ISO 11413.

In the case of assemblies incorporating a socket, prepare the test pieces in accordance with 5.2.2.

In the case of assemblies incorporating a saddle, prepare the test pieces in accordance with 5.2.3.

5.2.2 Electrofusion sockets

Cut the assembly into sectors as specified in table 1 (see also figure 1).

Table 1

Nominal outside diameter of pipe d_n	Number of sectors (see figure 1)	Angle	Minimum length of pipe each side of fitting
$16 \leq d_n < 90$	2	180°	$2d_n$ or 100 mm
$90 \leq d_n \leq 225$	4	90°	$2d_n$

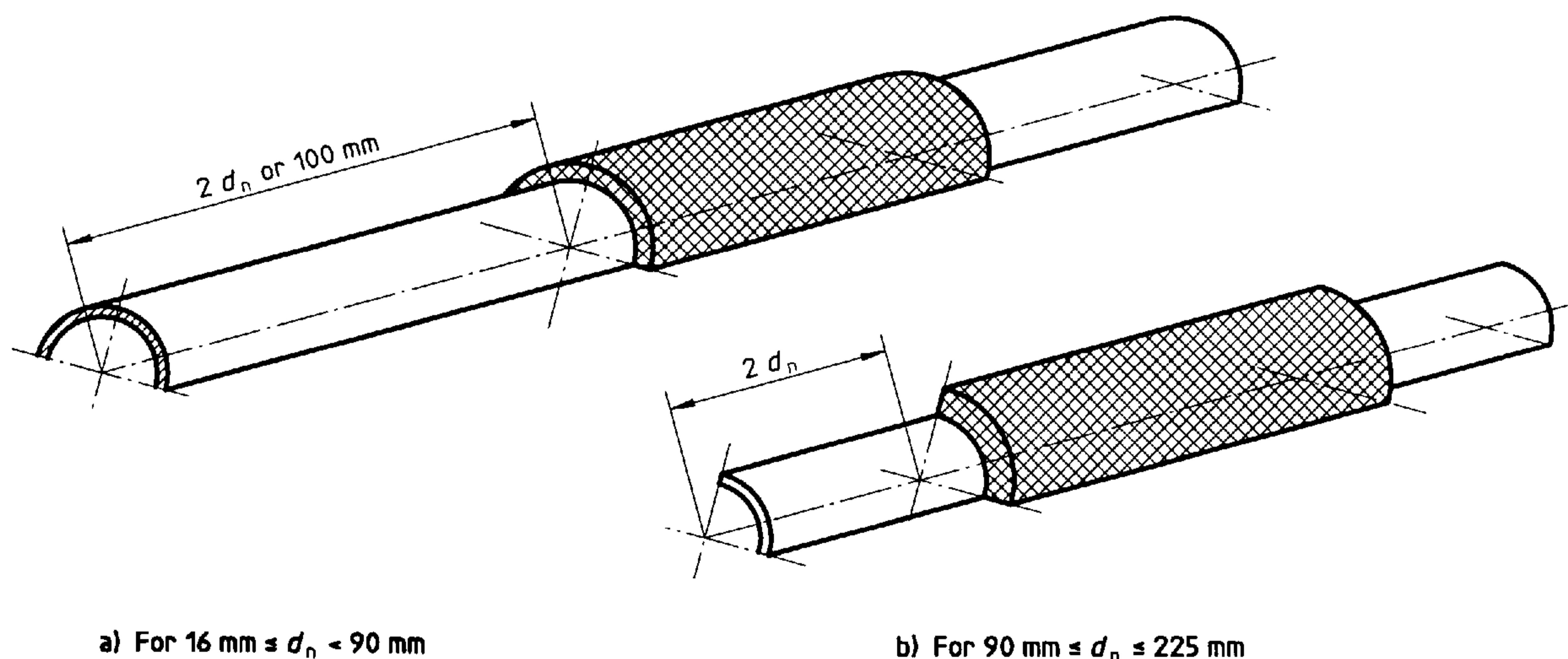

Figure 1 — Preparation of test pieces

5.2.3 Electrofusion saddles

Cut the assembly along a plane which passes through the axis of the pipe. This plane shall be perpendicular to the plane defined by the axis of the pipe and the centreline of the tapping tee or saddle as shown in figure 2.

5.3 Number of test pieces

The number of test pieces shall be as specified in the product standard.

NOTE — Testing of at least three test pieces is recommended.

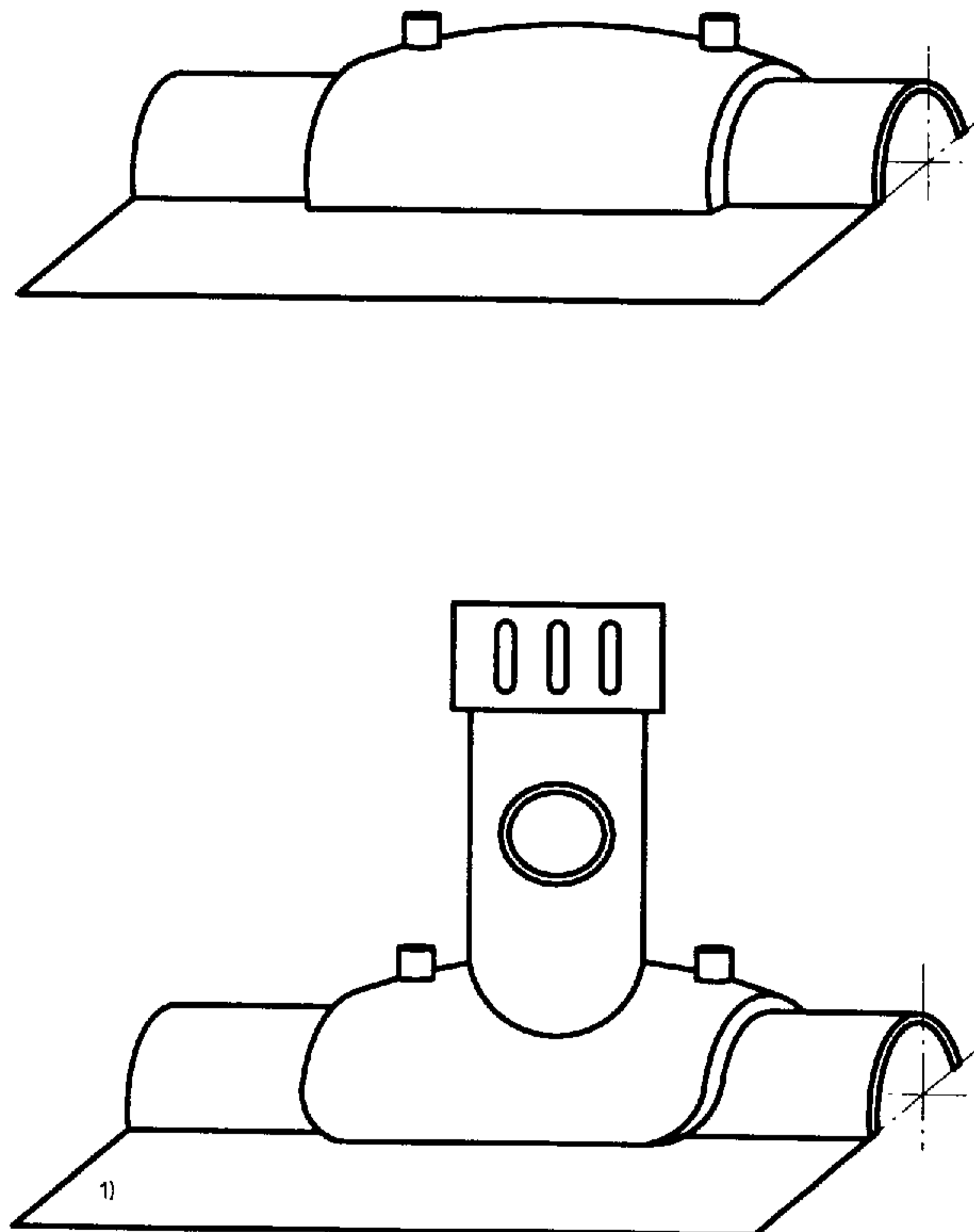

1) Cutting plane

Figure 2 — Test piece incorporating an electrofusion saddle

6 Conditioning

Carry out the procedure given in clause 7 at least 12 h after the fusion operation.

Between the fusion and cutting operations, condition the assembly for at least 6 h at $23\text{ °C} \pm 2\text{ °C}$.

After the test pieces have been cut from the assembly, leave them at the test temperature for at least 6 h.

7 Procedure

7.1 General

Carry out the following procedure at $23\text{ °C} \pm 2\text{ °C}$, in accordance with 7.2 in the case of test pieces incorporating an electrofusion socket or in accordance with 7.3 in the case of test pieces incorporating an electrofusion saddle.

7.2 Electrofusion sockets

7.2.1 Measure and record the overall distance y from the first to the last winding in the electrofusion socket as shown in figure 3.

7.2.2 Apply a compressive force, next to the electrofusion socket, to each test piece, using a compression speed of $100\text{ mm/min} \pm 10\%$, until the inside walls of the pipe touch each other. The distance between the limiting stops shall be equal to twice the pipe wall thickness.

7.2.3 Utilizing a lever, carefully separate the electrofusion socket from the pipe, using only small movements of the lever and without subjecting the test piece to any impacts.

Inspect the test piece and record the type of failure (e.g. in the pipe or the fitting, between the windings or at the interface).

7.2.4 Measure the total brittle-failure length d_2 in the fusion plane, at the outer edge of the fitting parallel to the pipe axis, as shown in figure 3.

7.2.5 For each test piece, calculate the percentage brittle-failure decohesion C_c from the brittle-failure length d_2 and the distance between the first and last windings y , using the following equation:

$$C_c = \frac{d_2}{y} \times 100$$

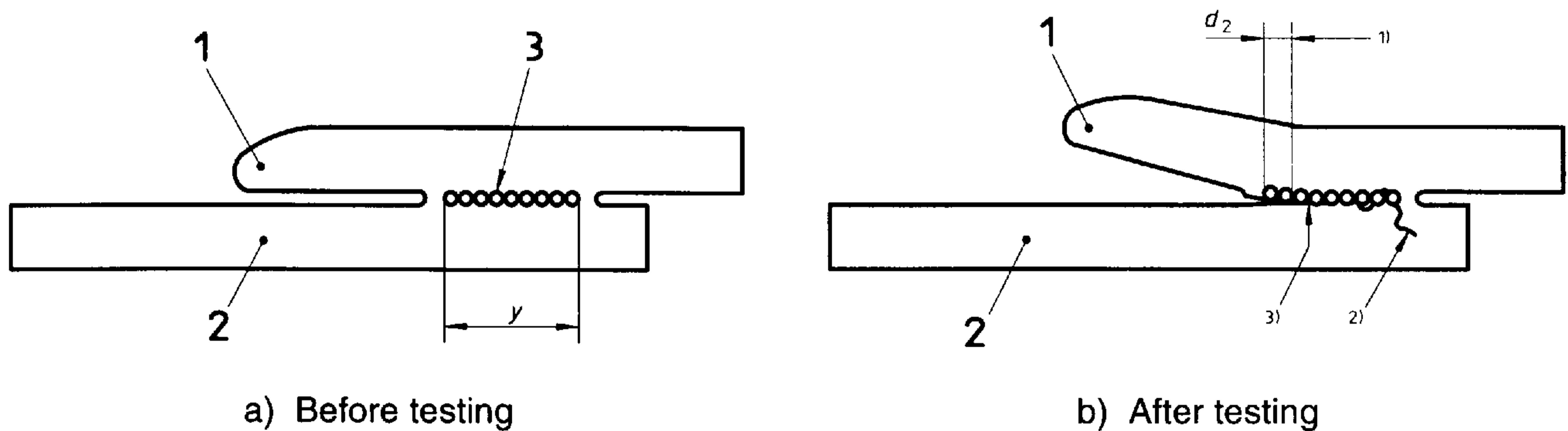

Key

- 1 Socket
- 2 Pipe
- 3 Coil windings

- 1) Brittle failure in the fusion plane
- 2) Ductile failure of the pipe
- 3) Failure in the plane of the coil with ductile deformation of the plastic material

Figure 3 — Assessment of decohesion of a test piece incorporating an electrofusion socket

7.3 Electrofusion saddles

7.3.1 Determine the area of the fusion plane S_T (see manufacturer's data sheet).

7.3.2 Position the test piece such that the compressive force is applied in a plane parallel to the plane through which the pipe was cut (see figure 4) and such that the platens of the compression-testing machine are next to the saddle. Apply an increasing compressive force to the test specimen in such a way that the platens approach each other at a speed of 100 mm/min \pm 10 %. Continue to compress the test piece until the distance between the platens has decreased to twice the thickness of the pipe wall. Record the compressive force just before the pipe walls make contact.

Dimensions in millimetres

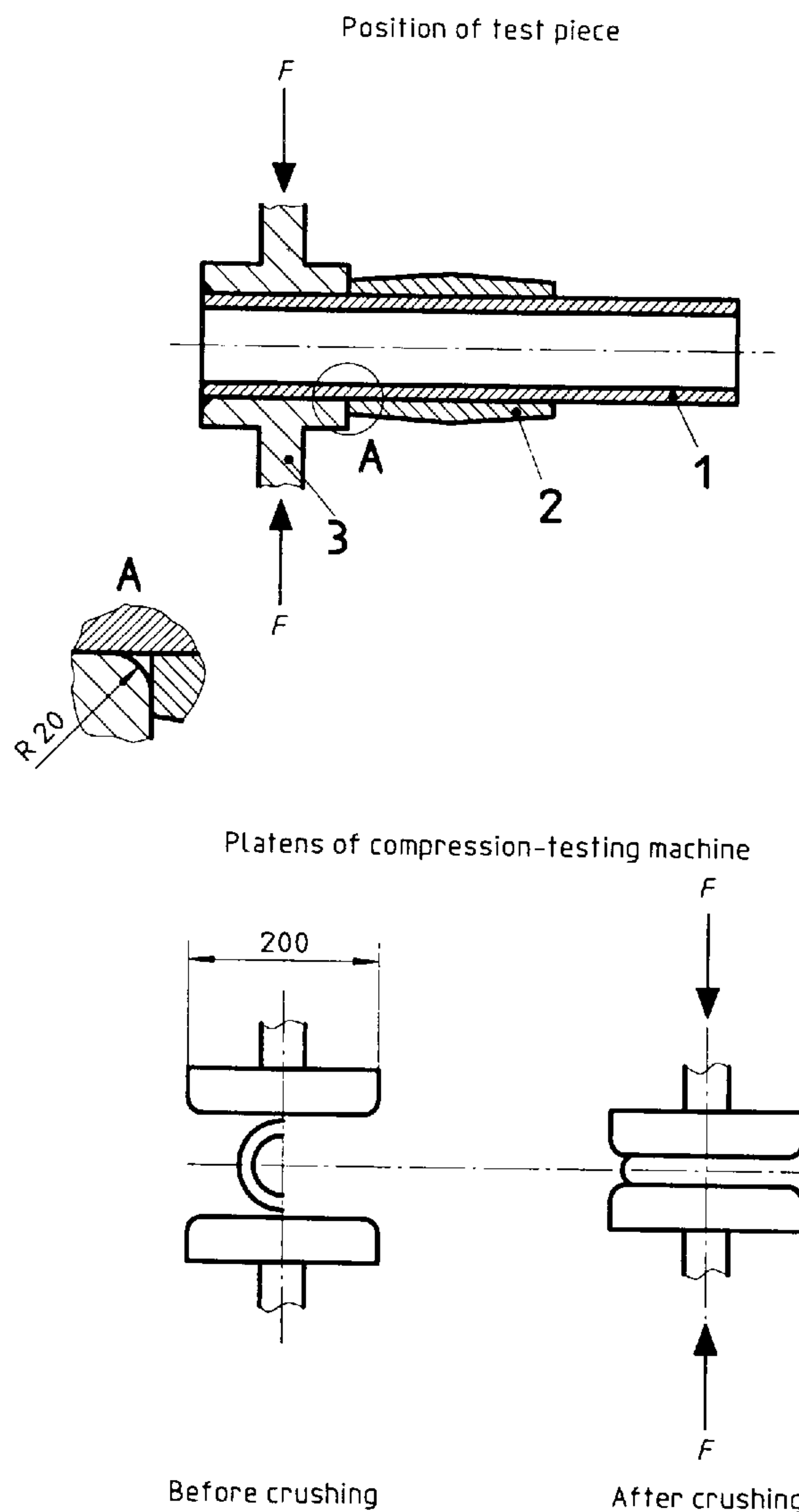

Key

- 1 Pipe
- 2 Fitting
- 3 Platen

Figure 4 — Mounting of the test piece between the platens of the compression-testing machine

7.3.3 Utilizing a lever, carefully separate the electrofusion socket from the pipe, using only small movements of the lever and without subjecting the test piece to any impacts.

Inspect the test piece and record the type of failure (e.g. in the pipe or the fitting, between the windings or at the interface).

7.3.4 Measure the total brittle-failure area S_F in the fusion plane.

7.3.5 Calculate the percentage brittle-failure decohesion C_c from the brittle-failure area S_F and the area of the fusion plane S_T , using the following equation:

$$C_c = \frac{S_F}{S_T} \times 100$$

8 Interpretation of results

If the percentage brittle-failure decohesion is higher than the value stated in the relevant product standard, the assembly is considered to have failed the test.

9 Test report

The test report shall include the following information:

- a) a reference to this International standard;
- b) full identification of the sample tested;
- c) the material of each of the components of the assembly tested;
- d) the nominal size of the fitting;
- e) the dimensions of the pipe before assembly (mean diameter, ovality, wall thickness and length);
- f) the dimensions of the test pieces, including the free length of pipe projecting from the socket;
- g) the fusion conditions used when preparing the assemblies;
- h) the test temperature and the accuracy to which it was measured;
- i) the number of test pieces tested;
- j) the length of time between fusion and cutting the test pieces from the assembly and the length of the conditioning period;
- k) in the case of electrofusion saddles: the compressive force at the moment when the distance between the platens was twice the pipe wall thickness;
- l) the percentage brittle-failure decohesion;
- m) in the case of failure, the type of failure (failure at the interface, tearing between windings failure of the pipe or failure of the socket);
- n) any special observations made during or after the test;
- o) the date of the test;
- p) the laboratory which carried out the test.

ICS 23.040.60

Descriptors: fluid pipelines, pipes (tubes), polyethylene, plastic tubes, pipe fittings, fusion welding, tests, cohesion tests, crushing tests.

Price based on 6 pages
