**Textiles — Determination of the slippage
resistance of yarns at a seam in woven
fabrics —**

**Part 1:
Fixed seam opening method**

*Textiles — Détermination de la résistance au glissement des fils de
couture dans les tissus —*

Partie 1: Méthode de l'ouverture de couture fixe



Reference number
ISO 13936-1:2004(E)

© ISO 2004

PDF disclaimer

This PDF file may contain embedded typefaces. In accordance with Adobe's licensing policy, this file may be printed or viewed but shall not be edited unless the typefaces which are embedded are licensed to and installed on the computer performing the editing. In downloading this file, parties accept therein the responsibility of not infringing Adobe's licensing policy. The ISO Central Secretariat accepts no liability in this area.

Adobe is a trademark of Adobe Systems Incorporated.

Details of the software products used to create this PDF file can be found in the General Info relative to the file; the PDF-creation parameters were optimized for printing. Every care has been taken to ensure that the file is suitable for use by ISO member bodies. In the unlikely event that a problem relating to it is found, please inform the Central Secretariat at the address given below.

© ISO 2004

All rights reserved. Unless otherwise specified, no part of this publication may be reproduced or utilized in any form or by any means, electronic or mechanical, including photocopying and microfilm, without permission in writing from either ISO at the address below or ISO's member body in the country of the requester.

ISO copyright office
Case postale 56 • CH-1211 Geneva 20
Tel. + 41 22 749 01 11
Fax + 41 22 749 09 47
E-mail copyright@iso.org
Web www.iso.org

Published in Switzerland

Contents

	Page
1 Scope	1
2 Normative references	1
3 Terms and definitions	1
4 Principle	2
5 Sampling	2
6 Apparatus and materials	2
7 Conditioning and testing atmosphere	4
8 Pretreatment	4
9 Preparation of test specimens	4
10 Test procedure	5
11 Calculation and Expression of Results	6
12 Test report	7
Annex A (informative) Suggested procedure for sampling	8
Annex B (informative) Example of pattern for cutting out test specimens from the laboratory sample	9
Bibliography	10

Foreword

ISO (the International Organization for Standardization) is a worldwide federation of national standards bodies (ISO member bodies). The work of preparing International Standards is normally carried out through ISO technical committees. Each member body interested in a subject for which a technical committee has been established has the right to be represented on that committee. International organizations, governmental and non-governmental, in liaison with ISO, also take part in the work. ISO collaborates closely with the International Electrotechnical Commission (IEC) on all matters of electrotechnical standardization.

International Standards are drafted in accordance with the rules given in the ISO/IEC Directives, Part 2.

The main task of technical committees is to prepare International Standards. Draft International Standards adopted by the technical committees are circulated to the member bodies for voting. Publication as an International Standard requires approval by at least 75 % of the member bodies casting a vote.

Attention is drawn to the possibility that some of the elements of this document may be the subject of patent rights. ISO shall not be held responsible for identifying any or all such patent rights.

ISO 13936-1 was prepared by Technical Committee ISO/TC 38, *Textiles*, Subcommittee SC 24, *Conditioning atmospheres and physical tests for textile fabrics*.

ISO 13936 consists of the following parts, under the general title *Textiles — Determination of the slippage resistance of yarns at a seam in woven fabrics*:

- *Part 1: Fixed seam opening method*
- *Part 2: Fixed load method*
- *Part 3: Needle clamp method*

Textiles — Determination of the slippage resistance of yarns at a seam in woven fabrics —

Part 1: Fixed seam opening method

1 Scope

This part of ISO 13936 is intended for the determination of the resistance offered by thread systems of woven fabric, to slippage at a sewn seam.

This method is not suitable for stretch fabrics or for industrial fabrics, e.g. beltings.

2 Normative references

The following referenced documents are indispensable for the application of this document. For dated references, only the edition cited applies. For undated references, the latest edition of the referenced document (including any amendments) applies.

ISO 139, *Textiles — Standard atmospheres for conditioning and testing*

ISO 4915:1991, *Textiles — Stitch types — Classification and terminology*

ISO 7500-1:—¹⁾, *Metallic materials — Verification of static uniaxial testing machines — Part 1: Tension/compression testing machines — Verification and calibration of the force-measuring system*

ISO 10012:2003, *Measurement management systems — Requirements for measurement processes and measuring equipment*

3 Terms and definitions

For the purposes of this document, the following terms and definitions apply.

3.1

constant rate of extension (CRE) testing machine

tensile testing machine where one clamp is fixed whilst the other is moving with a constant speed throughout the test and where the entire testing system is virtually free from deflection

3.2

grab test

tensile test in which only the centre part of the specimen is gripped in the jaws

3.3

yarn slippage, seam slippage

movement, in a woven fabric of weft yarns over warp yarns (or warp yarns over weft yarns) as a result of a pulling action

1) To be published.

NOTE Seam slippage is a fabric property and should not be confused with seam strength.

3.4

warp slippage

warp yarns slipping over weft yarns, i.e. the warp yarns are at right angles to the direction of pull

3.5

weft slippage

weft yarns slipping over warp yarns, i.e. the weft yarns are at right angles to the direction of pull

3.6

seam allowance

distance between the seam line and the adjacent edges of the material

3.7

seam opening

distance between the yarns which have been displaced on either side of the seam line

4 Principle

An unseamed and a seamed part of a test specimen are separately extended by using a tensile testing machine, fitted with grab test jaws, to produce, in the case of the use of a chart recorder, two force/extension curves originating from the same abscissa. The force required to produce a specified distance between the curves, equivalent to a specified seam opening is determined.

5 Sampling

Select samples either in accordance with the procedure laid down in the material specification for the fabric, or as agreed between the interested parties.

In the absence of specification, an example of a suitable sampling procedure is given in Annex A.

An example of a pattern for cutting test specimens is given in Annex B. Avoid test specimens from folded or creased areas, selvages and areas not representative of the fabric.

6 Apparatus and materials

6.1 CRE Machine

6.1.1 Metrological confirmation system of the tensile-testing machine shall be in accordance with ISO 10012. The constant-rate-of-extension (CRE) machine shall have the general characteristics given in 6.1.2 to 6.1.8.

6.1.2 The tensile-testing machine shall be provided with means for indicating or recording the force applied to the test specimen in extending it. Under conditions of use, the accuracy of the apparatus shall be class 1 of ISO 7500-1:— . The error of the indicated or recorded maximum force at any point in the range in which the machine is used shall not exceed $\pm 1\%$, and the error of the indicated recorded jaw separation shall not exceed ± 1 mm.

6.1.3 If recording of force is obtained by means of data acquisition boards and software, the frequency of data collection shall be at least 8 s^{-1} .

6.1.4 The machine shall be capable of constant rate of extension of 50 mm/min, with an accuracy of $\pm 10\%$.

6.1.5 The machine shall be capable of setting the gauge length to 100 mm.

6.1.6 The clamping device of the machine shall be positioned with the central point of the two jaws in the line of the applied force, the front edges shall be at right angles to the line of applied force and their clamping faces shall be in the same plane.

The jaws shall be capable of holding the test specimen without allowing it to slip and designed so that they do not cut or otherwise weaken the test specimen.

The faces of the jaws shall be smooth and flat, except that when, even with packing, the test specimen cannot be held satisfactorily with flat-faced jaws, engraved or corrugated jaws can be used to prevent slippage. Other auxiliary materials for use with either smooth or corrugated jaws to improve specimen gripping include paper, leather, plastics or rubber.

6.1.7 The area of the fabric clamped during the test shall be $(25 \text{ mm} \pm 1 \text{ mm}) \times (25 \text{ mm} \pm 1 \text{ mm})$. This area can be achieved by either method a) or method b) as described below.

- a) The rear clamp shall be $25 \text{ mm} \times 40 \text{ mm}$ min (preferably 50 mm), positioned with the wider direction of the clamp perpendicular to the line of the application of the force; the front clamp shall be of the same dimensions positioned perpendicular to the first so that the wider direction of the clamp is parallel to the direction of the application of the force.
- b) The rear clamp shall be $25 \text{ mm} \times 40 \text{ mm}$ min (preferably 50 mm), positioned with the wider direction of the clamp perpendicular to the line of application of the force; the front clamp shall be $25 \text{ mm} \times 25 \text{ mm}$.

6.1.8 A device for recording force and extension is necessary if the tensile tester is not computer-controlled.

6.2 Equipment for cutting test specimens

6.3 Sewing machine, electrically operated, single needle, lock stitch, capable of producing stitch type 301 as described in ISO 4915:1991 (see Figure 1).

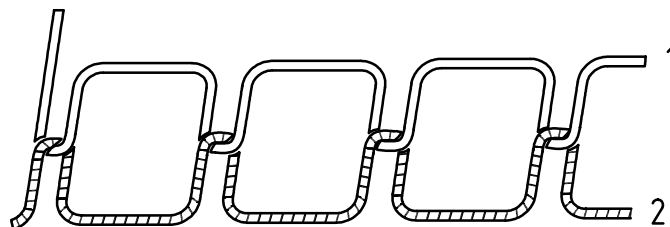

Key

- 1 needle thread
- 2 bobbin thread

Figure 1 — Stitch type 301

This stitch type is formed with two threads: one needle thread and one bobbin thread. A loop of thread 1 is passed through the material from the needle side and is interlaced with thread on the other side. Thread 1 is pulled back so that the interlacing comes midway between the surfaces of the material being sewn.

This stitch type is sometimes produced from a single thread, in which case the first stitch differs from subsequent stitches.

A minimum of two stitches describes this stitch type.

6.4 Needles, throat-plate and feed-dog, see Table 1 and 9.1.

6.5 Sewing thread, suitable, as specified in Table 1.

6.6 Calibrated rule, graduated in 0,5 millimetres divisions.

7 Conditioning and testing atmosphere

The standard atmosphere for conditioning and testing textiles as defined in ISO 139 shall be used.

8 Pretreatment

If a pre-treatment is required, launder or dry clean the sample using a method agreed between the interested parties. The procedures described in ISO 6330 or ISO 3175-2 may be suitable.

9 Preparation of test specimens

9.1 Adjustment of sewing machine

Insert the needle together with the corresponding throat-plate and feed-dog, and set the machine to give stitch density for the fabric under test as indicated in Table 1, by sewing a double thickness piece of the test fabric.

Adjust the thread tension as follows: with the lower thread bobbin in its case removed from the machine, hold the thread issuing from the bobbin case so as to allow the case to run down the thread as it unwinds. Adjust the tension spring on the bobbin case so that the case runs down the thread at a slow uniform speed. Replace the bobbin case in the machine and adjust the tension of the thread feed to the needle so that when a double thickness of the fabric under test is stitched the cross-over between the needle thread and the bobbin or shuttle thread is located midway between the upper and lower surfaces of the seam (see Figure 1).

Table 1 — Requirements for stitching

Class of fabric	Sewing thread	Needle size		Stitches/100 mm
	100 % polyester core spun (filament core, staple sheath) of approximate resultant linear density tex	metric	mm	
Apparel fabric	45 ± 5	90	0,90	50 ± 2

NOTE Ensure the needle is undamaged by examining under magnification.

9.2 Cutting and sewing of test specimens

9.2.1 For warp slippage prepare five specimens each 100 mm wide in the warp direction and 400 mm long in the weft direction. For weft slippage prepare five specimens each 100 mm wide in the weft direction and 400 mm long in the warp direction.

In accordance with Clause 5 and Annex B no test specimen shall be cut from within 150 mm of either edge of the laboratory sample. Wherever possible, no two specimens in any group of five shall contain the same warp or weft threads.

9.2.2 Fold each specimen face inwards 110 mm from one end and parallel to the threads of the 100 mm side. Make a lockstitch seam at a distance of 20 mm from the fold line as shown in Figure 1. Draw a guideline 38 mm from and parallel to one of the long edges of each test specimen to enable the jaws to be aligned on the same threads in the seamed and the unseamed test specimen during testing.

9.2.3 Cut each seamed specimen 12 mm from the sewn seam line cutting through both layers of the fabric (see Figure 2). The seam allowance shall be the same on each side of the cut.

9.2.4 Cut each specimen 110 mm from the fold line parallel to the seam. In this way two test specimens are produced, one with a lockstitch seam, the other without a lockstitch seam, 180 mm in length.

Dimensions in millimetres

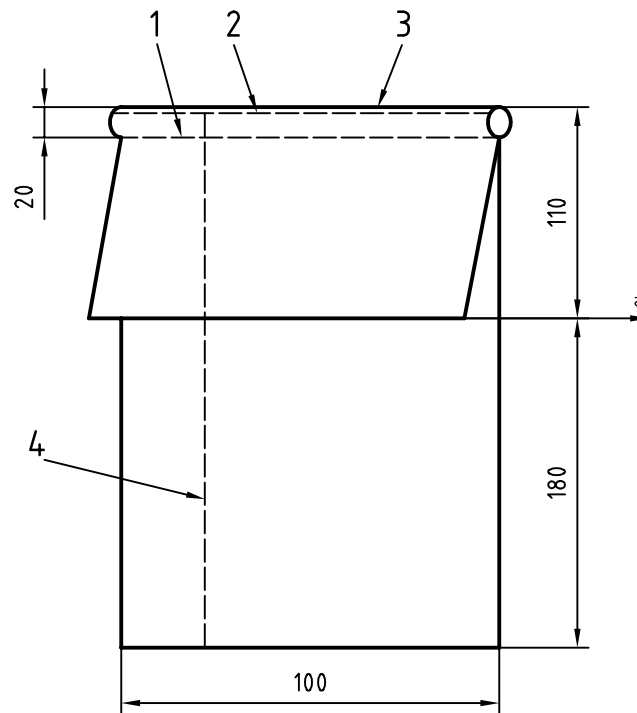
**Key**

- 1 seam line (20 mm from fold line)
- 2 cutting line (12 mm from seam line)
- 3 fold line
- 4 guide line (38 mm from edge)

^a Cutting line direction.

Figure 2 — Preparation of test specimens

10 Test procedure

10.1 Condition the test specimens in accordance with Clause 7.

10.2 Set the clamps of the tensile testing machine a distance of (100 ± 1) mm apart, taking care that the clamps are properly aligned and parallel to each other.

10.3 Set the tensile testing machine to give a constant rate of jaw separation of (50 ± 5) mm/min.

10.4 Clamp the unseamed test specimen in the jaws ensuring that the test specimen is mounted centrally, and carry out a grab tensile test until a force of 200 N is exceeded. If the tensile testing machine is not computer-controlled, set the chart recorder:crosshead speed ratio to a minimum of 5:1 in order to produce a force/extension curve of the required accuracy.

10.5 Clamp the seamed test specimen in the jaws ensuring that the seam is midway between and parallel to the jaws, and carry out a second grab tensile test. If the tensile testing machine is not computer-controlled produce a second force/extension curve from the same starting point on the chart as in the case of the curve for the unseamed specimen (see Figure 3).

10.6 Repeat this procedure with the remaining test specimens so that five separate pairs of curves are produced for the warp direction and five for the weft direction.

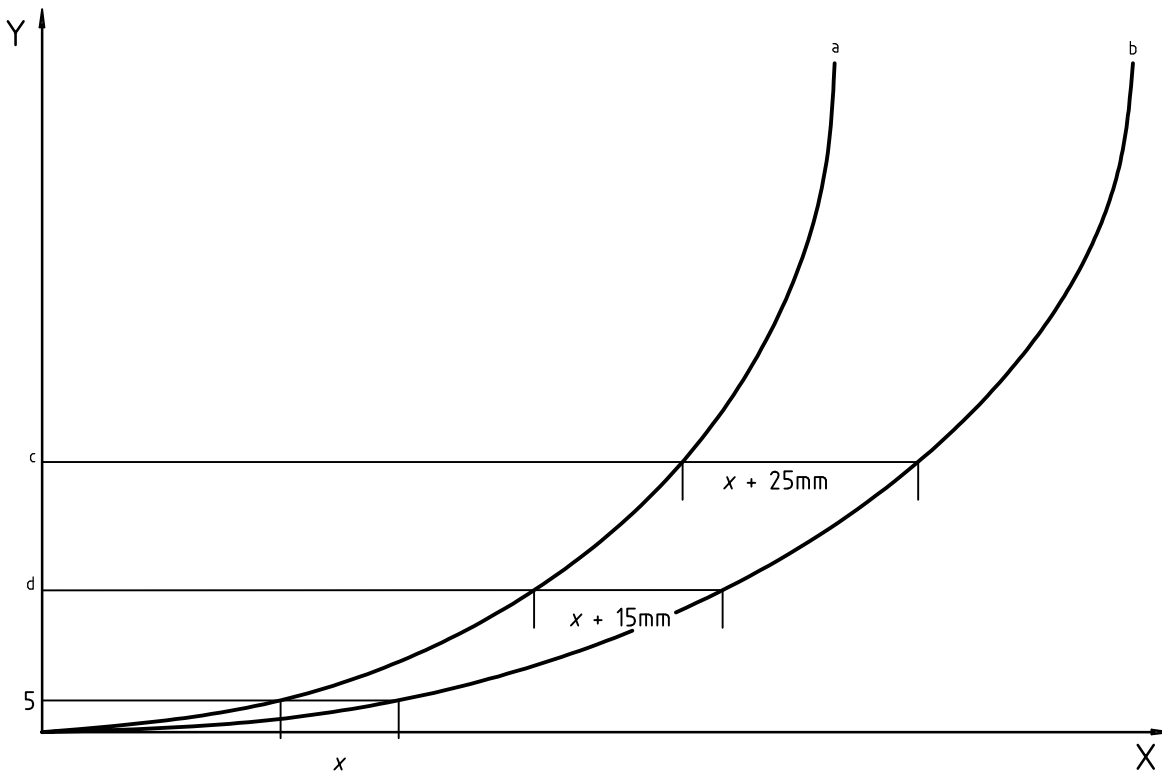

Key

X extension, mm
 Y force, N

- a Unseamed specimen.
- b Seamed specimen.
- c Load equivalent to a seam opening of 5 mm.
- d Load equivalent to a seam opening of 3 mm.

Figure 3 — Example of calculating the seam opening manually from a chart recorder

11 Calculation and expression of results

11.1 If using a chart recorder, for each pair of curves, proceed as follows (see Figure 3).

- a) Measure the distance, x , to the nearest 0,5 mm between the curves with and without seam, at a load of 5 N. This is to compensate for any initial straightening of the specimens.
- b) Add the distance, x , to the “distance to measure” given in Table 2, to give x' for the seam opening required.
- c) Find the point on each pair of curves where the separation between them, parallel to the extension axis, is equal to x' . Read off the force in newtons to the nearest newton at this separation.

11.2 When using data acquisition boards or computer software, record the test results directly.

11.3 Report the mean of the five warp slippage and five weft slippage results separately to the nearest newton.

11.4 If the required separation between the curves cannot be measured at or below a force of 200 N, report the result as “greater than 200 N”.

11.5 If the fabric tears or seam breaks at a force of 200 N or less, and the gap cannot be found report the result as “fabric breakdown” or “seam breakdown” and quote the force at which this occurred.

Table 2 — Distance to measure for each specified seam opening using a chart recorder

Seam opening mm	Distance to measure (based on chart:crosshead ratio of 5:1)
2	10
3	15
4	20
5	25
6	30

12 Test report

The test report shall include the following information:

- a) reference to this part of ISO 13936, i.e. ISO 13936-1, and the date of test;
- b) identification of test sample and sampling procedure, if required;
- c) seam opening selected, in millimetres;
- d) mean force, in newtons, for the specified seam opening in Table 2 for warp and/or weft slippage;
- e) individual test results, if required;
- f) if applicable, a statement “more than 200 N”, “fabric breakdown” or “seam breakdown” and the force at which this occurred;
- g) end use of the fabric under test (if known);
- h) any deviation from the given procedure;
- i) method of calculation, i.e. manual or computer controlled.

Annex A (informative)

Suggested procedure for sampling

A.1 Bulk Sampling (number of pieces taken from a shipment or lot)

Take at random from the shipment or lot the appropriate number of pieces shown in Table A.1. Ensure that no piece that shows signs of damage or dampness incurred during transit is included in the bulk sample.

Table A.1 — Bulk sampling

Number of pieces in shipment or lot	Number of pieces comprising bulk sample, minimum
3 or less	1
4 to 10	2
11 to 30	3
31 to 75	4
76 or more	5

A.2 Number of laboratory samples

From each piece in the bulk sample, cut (from a position taken at random but at least 3 m from the end of a piece) a laboratory sample of length of at least 1 m and of full width. Ensure that areas that are creased or that have a visible fault, or faults, are not included in the laboratory sample.

Annex B
(informative)

Example of pattern for cutting out test specimens from the laboratory sample

Dimensions in millimetres

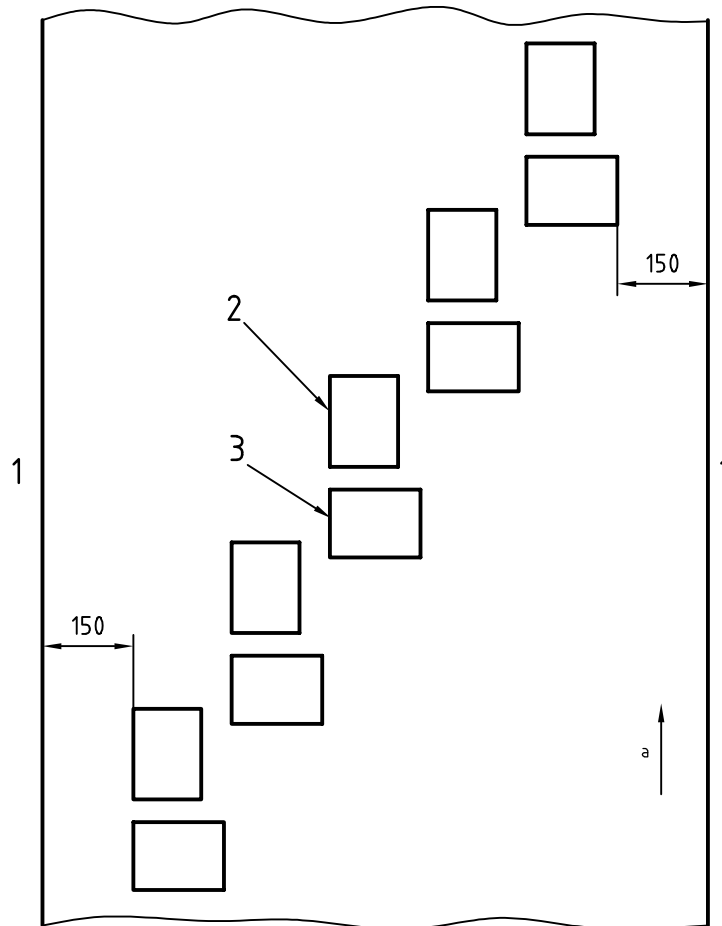

Key

- 1 edge
- 2 specimen for slippage of weft yarns over warp yarns
- 3 specimen for slippage of warp yarns over weft yarns
- ^a Warp direction.

Figure B.1

Bibliography

- [1] ISO 3175-2, *Textiles — Professional care, drycleaning and wetcleaning of fabrics and garments — Part 2: Procedure for testing performance when cleaning and finishing using tetrachloroethene*
- [2] ISO 6330, *Textiles — Domestic washing and drying procedures for textile testing*

ICS 59.080.30

Price based on 10 pages