

First edition
1996-08-01

**Welding — General tolerances for welded
constructions — Dimensions for lengths
and angles — Shape and position**

*Soudage — Tolérances générales relatives aux constructions soudées —
Dimensions des longueurs et angles — Formes et positions*



Reference number
ISO 13920:1996(E)

Foreword

ISO (the International Organization for Standardization) is a worldwide federation of national standards bodies (ISO member bodies). The work of preparing International Standards is normally carried out through ISO technical committees. Each member body interested in a subject for which a technical committee has been established has the right to be represented on that committee. International organizations, governmental and non-governmental, in liaison with ISO, also take part in the work. ISO collaborates closely with the International Electrotechnical Commission (IEC) on all matters of electrotechnical standardization.

Draft International Standards adopted by the technical committees are circulated to the member bodies for voting. Publication as an International Standard requires approval by at least 75 % of the member bodies casting a vote.

International Standard ISO 13920 was prepared by the European Committee for Standardization (CEN) in collaboration with ISO Technical Committee TC 44, *Welding and allied processes*, Subcommittee SC 10, *Unification of requirements in the field of metal welding*, in accordance with the Agreement on technical cooperation between ISO and CEN (Vienna Agreement).

© ISO 1996

All rights reserved. Unless otherwise specified, no part of this publication may be reproduced or utilized in any form or by any means, electronic or mechanical, including photocopying and microfilm, without permission in writing from the publisher.

International Organization for Standardization
Case postale 56 • CH-1211 Genève 20 • Switzerland
Internet central@isocs.iso.ch
X.400 c=ch; a=400net; p=iso; o=isocs; s=central

Printed in Switzerland

Content

	page
Foreword	iv
1 Scope	1
2 Normative references	1
3 Definitions	2
4 General tolerances	2
4.1 Tolerances for linear dimensions	2
4.2 Tolerances for angular dimensions	2
4.3 Straightness, flatness and parallelism tolerances	4
5 Indications on drawings	5
6 Testing	5
6.1 General	5
6.2 Straightness	5
6.3 Flatness	6
6.4 Parallelism	6
7 Non-conformities	6

Foreword

The text of EN ISO 13920:1996 has been prepared by Technical Committee CEN/TC 121 "Welding", the secretariat of which is held by DS, in collaboration with Technical Committee ISO/TC 44 "Welding and allied processes".

This European Standard shall be given the status of a national standard, either by publication of an identical text or by endorsement, at the latest by February 1997, and conflicting national standards shall be withdrawn at the latest by February 1997.

According to the CEN/CENELEC Internal Regulations, the national standards organizations of the following countries are bound to implement this European Standard: Austria, Belgium, Denmark, Finland, France, Germany, Greece, Iceland, Ireland, Italy, Luxembourg, Netherlands, Norway, Portugal, Spain, Sweden, Switzerland and the United Kingdom.

1 Scope

This European Standard specifies general tolerances for linear and angular dimensions and for shape and position of welded structures in four tolerance classes, these being based on customary workshop accuracy. The main criterion for the selection of a particular tolerance class should be the functional requirements which are to be met.

The applicable tolerances are always those which are stated in the drawing. Instead of specifying individual tolerances the tolerance classes according to this standard may be used.

General tolerances for linear and angular dimensions and for shape and position as specified in this standard apply for weldments, welding assemblies and welded structures etc.

Special provisions may be necessary for complex structures.

The specifications given in this standard are based on the principle of independency as specified in ISO 8015, according to which the dimensional and geometrical tolerances apply independently of each other.

Manufacturing documentation in which linear and angular dimensions or indications for shape and position are presented without individually indicated tolerances shall be deemed incomplete if there is no, or inadequate, reference to general tolerances. This does not apply to temporary dimensions.

2 Normative references

This European Standard incorporates by dated or undated reference, provisions from other publications. These normative references are cited at the appropriate place in the text and the publications are listed hereafter. For dated references, subsequent amendments to or revisions of any of these publications apply to this European Standard only when incorporated in it by amendment or revision. For undated references the last edition of the publication referred to applies.

ISO/DIS 463	Geometrical Product Specifications (GPS) - Dimensional measuring instruments; Dial gauges - Design and metrological requirements
prEN ISO 1101	Technical drawings - Geometrical tolerancing Tolerances of form, orientation, location and run-out - Generalities, definitions, symbols, indications on drawings (ISO/DIS 1101:1995)
ISO 3599	Vernier callipers reading to 0,1 and 0,05 mm
ISO 6906	Vernier callipers reading to 0,02 mm
ISO 8015	Technical drawings - Fundamental tolerancing principle

3 Definitions

For the purposes of this standard the definitions of prEN ISO 1101 apply.

4 General tolerances

4.1 Tolerances for linear dimensions

See table 1.

Table 1: Tolerances for linear dimensions

Range of nominal sizes l in mm											
Tolerance class	2 to 30	Over 30 up to 120	Over 120 up to 400	Over 400 up to 1000	Over 1000 up to 2000	Over 2000 up to 4000	Over 4000 up to 8000	Over 8000 up to 12000	Over 12000 up to 16000	Over 16000 up to 20000	Over 20000
	Tolerances t in mm										
A	± 1	± 1	± 1	± 2	± 3	± 4	± 5	± 6	± 7	± 8	± 9
B		± 2	± 2	± 3	± 4	± 6	± 8	± 10	± 12	± 14	± 16
C		± 3	± 4	± 6	± 8	± 11	± 14	± 18	± 21	± 24	± 27
D		± 4	± 7	± 9	± 12	± 16	± 21	± 27	± 32	± 36	± 40

4.2 Tolerances for angular dimensions

The length of the shorter angle leg shall be used to determine in accordance with table 2 which tolerances are to apply. The length of the leg may also be assumed to extend to a specified reference point. In this case, the reference point concerned shall be indicated on the drawing.

See table 2 for the relevant tolerances.

Figures 1 to 5 show examples of how the shorter angle leg, l , is represented.

Table 2: Tolerances for angular dimensions

Tolerance class	Range of nominal sizes l in mm (length or shorter leg)		
	Up to 400	Over 400 up to 1000	Over 1000
Tolerances $\Delta\alpha$ (in degrees and minutes)			
A	$\pm 20'$	$\pm 15'$	$\pm 10'$
B	$\pm 45'$	$\pm 30'$	$\pm 20'$
C	$\pm 1^\circ$	$\pm 45'$	$\pm 30'$
D	$\pm 1^\circ 30'$	$\pm 1^\circ 15'$	$\pm 1^\circ$
Calculated and rounded tolerances t , in mm/m ²)			
A	± 6	$\pm 4,5$	± 3
B	± 13	± 9	± 6
C	± 18	± 13	± 9
D	± 26	± 22	± 18

¹⁾ The value indicated in mm/m corresponds to the tangent value of the general tolerance. It is to be multiplied by the length, in m, of the shorter leg.

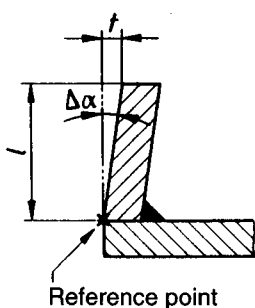

Figure 1

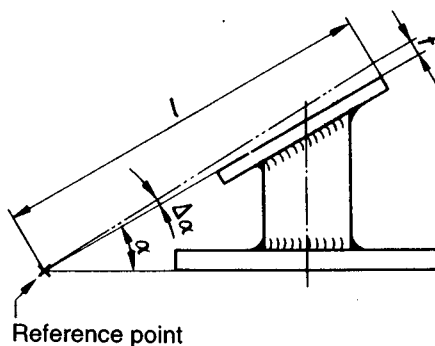

Figure 2

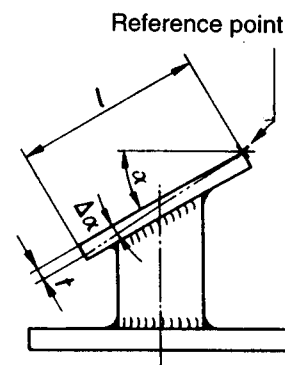

Figure 3

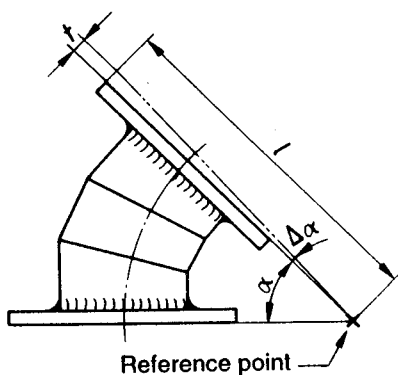

Figure 4.

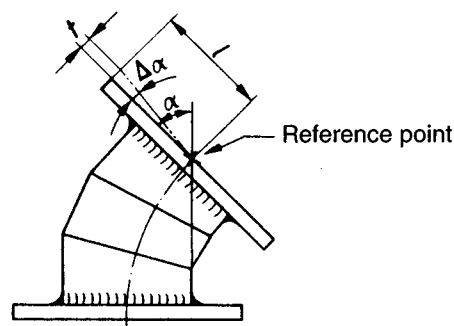

Figure 5.

4.3 Straightness, flatness and parallelism tolerances

The straightness, flatness and parallelism tolerances as specified in the following table 3 apply both for the overall dimensions of a weldment, a welding assembly, or a welded structure, and also for sections for which the dimensions are indicated.

Other tolerances of form and position, e.g. coaxiality and symmetry tolerances, have not been specified. If such tolerances are required for reasons of function, they shall be indicated on the drawings as specified in prEN ISO 1101.

Table 3: Straightness, flatness and parallelism tolerances

Range of nominal sizes l in mm (relates to longer side of the surface)										
Tolerance class	Over 30 up to 120	Over 120 up to 400	Over 400 up to 1000	Over 1000 up to 2000	Over 2000 up to 4000	Over 4000 up to 8000	Over 8000 up to 12000	Over 12000 up to 16000	Over 16000 up to 20000	Over 20000
	Tolerances t in mm									
E	0,5	1	1,5	2	3	4	5	6	7	8
F	1	1,5	3	4,5	6	8	10	12	14	16
G	1,5	3	5,5	9	11	16	20	22	25	25
H	2,5	5	9	14	18	26	32	36	40	40

5 Indications on drawings

The designation of the selected tolerance class as specified in table 1 and table 2 (e.g. EN ISO 13920-B) or its combination with a tolerance class as specified in table 3 (e.g. EN ISO 13920-BE), shall be entered in the appropriate area on the drawing.

6 Testing

6.1 General

Testing and measuring devices used shall be suitable and accurate for their intended purpose.

- graduated steel straightedges;
- tape measures;
- straightedges;
- squares;
- vernier callipers (in accordance with ISO 1599 and ISO 6906);
- dial gauges (in accordance with ISO/DIS 463).

Other testing and measuring devices may be used by agreement.

The results of measurement may be influenced if they are obtained under unusual temperature or atmospheric conditions, e.g. large constructions in strong sunlight.

The actual size of an angle shall be determined by applying suitable measuring devices tangentially to the weldment, but away from the zone immediately influenced by the weld. The deviation shall be derived from the difference between the nominal size and the actual size. The angular deviation may be measured in degrees and minutes, or in millimetres.

6.2 Straightness

The edge of the weldment and the straightedge shall be aligned in such a way that the greatest distance between the straightedge and the actual surface is at its minimum. The distance between the edge and the straightedge shall be measured (example see figure 6).

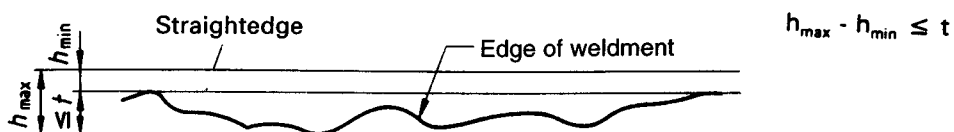

Figure 6: Straightness test

6.3 Flatness

The actual surface of the weldment and the measuring plane shall be aligned to each other in such a way that the greatest distance between the measuring plane and the actual surface is at its minimum. This may be effected, for example, with the aid of optical devices, tubular water levels, span wires, floor plates, surface plates, and machine beds.

The distances between the actual surface and the measuring plane shall be measured (example see figure 7).

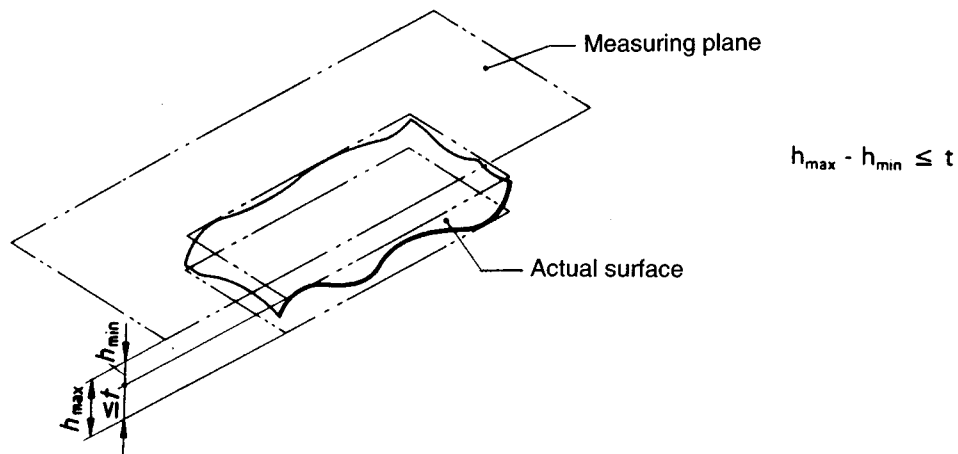

Figure 7: Flatness test

6.4 Parallelism

The reference surface shall be aligned parallel to the reference plane.

A measuring plane shall be established parallel to the reference plane and apart from the weldment, using the measuring devices referred to in 6.3. The distances between the actual surface and the measuring plane shall be measured (example see figure 8).

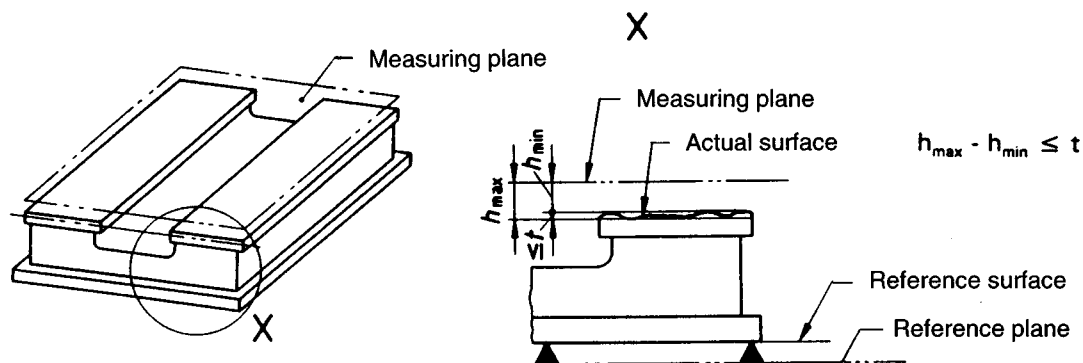

Figure 8: Parallelism test

7 Non-conformities

A decision on the acceptance of components not complying with this standard may be made on the basis of the suitability for their intended purpose.

ICS 17.040.10; 25.160.10

Descriptors: welding, welded construction, shape, position (location), dimensions, length, angles (geometry), dimensional tolerances, angular tolerances, tests.

Price based on 6 pages
