**Hard coal and coke — Mechanical
sampling —**

Part 6:

Coke — Preparation of test samples

Houille et coke — Échantillonnage mécanique —

Partie 6: Coke — Préparation des échantillons pour essai



COPYRIGHT PROTECTED DOCUMENT

© ISO 2016, Published in Switzerland

All rights reserved. Unless otherwise specified, no part of this publication may be reproduced or utilized otherwise in any form or by any means, electronic or mechanical, including photocopying, or posting on the internet or an intranet, without prior written permission. Permission can be requested from either ISO at the address below or ISO's member body in the country of the requester.

ISO copyright office
Ch. de Blandonnet 8 • CP 401
CH-1214 Vernier, Geneva, Switzerland
Tel. +41 22 749 01 11
Fax +41 22 749 09 47
copyright@iso.org
www.iso.org

Contents

Page

Foreword	v
Introduction	vi
1 Scope	1
2 Normative references	1
3 Terms and definitions	1
4 Precision of sample preparation	1
5 Constitution of a sample	2
5.1 General.....	2
5.2 Combination of increments.....	2
5.3 Combination of samples.....	2
6 Division	3
6.1 General.....	3
6.2 Mechanical methods.....	9
6.2.1 General.....	9
6.2.2 Mass of cut.....	10
6.2.3 Interval between cuts.....	11
6.2.4 Division of individual increments.....	11
6.2.5 Minimum mass of divided increment.....	11
6.2.6 Division of samples.....	12
6.3 Manual methods.....	12
6.3.1 General.....	12
6.3.2 Riffle method.....	12
6.3.3 Flattened-heap method.....	13
6.3.4 Strip-mixing and splitting method.....	15
7 Preparation of samples for specific tests	16
7.1 Types of test sample.....	16
7.2 Preparation of samples for determining total moisture.....	18
7.2.1 General.....	18
7.2.2 Procedure.....	18
7.2.3 Wet samples.....	18
7.2.4 Reduction of total moisture test sample.....	19
7.2.5 Division.....	19
7.2.6 Determination of total moisture.....	19
7.2.7 Reserve sample.....	19
7.3 Preparation of sample for general analysis.....	19
7.3.1 General.....	19
7.3.2 Preparation errors.....	19
7.3.3 Reduction.....	20
7.3.4 Division.....	20
7.3.5 Preparation errors.....	20
7.4 Storage.....	20
7.5 Physical test sample.....	20
7.6 Samples for special properties.....	20
8 Design of equipment for preparation	21
8.1 Dividers.....	21
8.2 Design of cutters for falling-stream dividers.....	21
8.2.1 General.....	21
8.2.2 Cutter velocity.....	21
8.3 Crushers.....	22
8.3.1 General.....	22
8.3.2 Examples of crushers.....	22

8.4	Preparation systems.....	22
8.4.1	General.....	22
8.4.2	Design criteria.....	23
8.4.3	Normal operation.....	23
8.4.4	Abnormal operation.....	23
8.4.5	Provision for checking for precision.....	23
8.4.6	Provision for testing for bias.....	24
Bibliography		25

Foreword

ISO (the International Organization for Standardization) is a worldwide federation of national standards bodies (ISO member bodies). The work of preparing International Standards is normally carried out through ISO technical committees. Each member body interested in a subject for which a technical committee has been established has the right to be represented on that committee. International organizations, governmental and non-governmental, in liaison with ISO, also take part in the work. ISO collaborates closely with the International Electrotechnical Commission (IEC) on all matters of electrotechnical standardization.

The procedures used to develop this document and those intended for its further maintenance are described in the ISO/IEC Directives, Part 1. In particular the different approval criteria needed for the different types of ISO documents should be noted. This document was drafted in accordance with the editorial rules of the ISO/IEC Directives, Part 2 (see www.iso.org/directives).

Attention is drawn to the possibility that some of the elements of this document may be the subject of patent rights. ISO shall not be held responsible for identifying any or all such patent rights. Details of any patent rights identified during the development of the document will be in the Introduction and/or on the ISO list of patent declarations received (see www.iso.org/patents).

Any trade name used in this document is information given for the convenience of users and does not constitute an endorsement.

For an explanation on the meaning of ISO specific terms and expressions related to conformity assessment, as well as information about ISO's adherence to the WTO principles in the Technical Barriers to Trade (TBT), see the following URL: [Foreword - Supplementary information](#)

The committee responsible for this document is ISO/TC 27, *Solid mineral fuels*, Subcommittee SC 4, *Sampling*.

This second edition cancels and replaces the first edition (ISO 13909-6:2001), which has been technically revised.

ISO 13909 consists of the following parts, under the general title *Hard coal and coke — Mechanical sampling*:

- *Part 1: General introduction*
- *Part 2: Coal — Sampling from moving streams*
- *Part 3: Coal — Sampling from stationary lots*
- *Part 4: Coal — Preparation of test samples*
- *Part 5: Coke — Sampling from moving streams*
- *Part 6: Coke — Preparation of test samples*
- *Part 7: Methods for determining the precision of sampling, sample preparation and testing*
- *Part 8: Methods of testing for bias*

Introduction

The objective of sample preparation is to prepare one or more test samples from the primary increments for subsequent analysis. The requisite mass and particle size of the test samples depend on the test to be carried out.

Examples of tests which require different masses are Shatter Index (ISO 616), Micum and Irsid Index (ISO 556), reactivity tests (ISO 18894), density (ISO 567, ISO 1013) and size distribution (ISO 728, ISO 2325).

The process of sample preparation may involve constitution of samples, reduction, division, mixing and drying or all or a combination of these.

Primary increments may be prepared individually as test samples or combined to constitute samples either as taken or after having been prepared by reduction and/or division. Samples may either be prepared individually as test samples or combined on a weighted basis to constitute a further sample.

Hard coal and coke — Mechanical sampling —

Part 6: Coke — Preparation of test samples

1 Scope

This part of ISO 13909 describes the preparation of samples of coke from the combination of primary increments to the preparation of samples for specific tests.

2 Normative references

The following documents, in whole or in part, are normatively referenced in this document and are indispensable for its application. For dated references, only the edition cited applies. For undated references, the latest edition of the referenced document (including any amendments) applies.

ISO 579, *Coke — Determination of total moisture*

ISO 687, *Solid mineral fuels — Coke — Determination of moisture in the general analysis test sample*

ISO 13909-1, *Hard coal and coke — Mechanical sampling — Part 1: General introduction*

ISO 13909-5, *Hard coal and coke — Mechanical sampling — Part 5: Coke — Sampling from moving streams*

ISO 13909-7, *Hard coal and coke — Mechanical sampling — Part 7: Methods for determining the precision of sampling, sample preparation and testing*

ISO 13909-8, *Hard coal and coke — Mechanical sampling — Part 8: Methods of testing for bias*

ISO 21398, *Hard coal and coke — Guidance to the inspection of mechanical sampling systems*

3 Terms and definitions

For the purposes of this document, the terms and definitions given in ISO 13909-1 apply.

4 Precision of sample preparation

From the formulae given in ISO 13909-7, the estimated absolute value of the precision of the result obtained for the lot at the 95 % confidence level, P_L , for continuous sampling is given by [Formula \(1\)](#):

$$P_L = 2\sqrt{\frac{\frac{V_I}{n} + V_{PT}}{m}} \quad (1)$$

where

V_I is the primary increment variance;

n is the number of increments in the sample;

V_{PT} is the variance of preparation and testing for both off-line and on-line systems;

m is the number of sub-lots.

The procedures given in this part of ISO 13909 are designed to achieve levels of V_{PT} of 0,05 or less for moisture tests. Better levels may be expected for other chemical characteristics.

For some preparation schemes, however, practical restrictions may prevent the preparation and testing variance being as low as this. Under these circumstances, the user should decide whether to achieve the desired overall precision by improving the preparation scheme or by dividing the lot into a greater number of sub-lots.

The errors occurring in the various stages of preparation and analysis, expressed in terms of variance, may be checked by the methods given in ISO 13909-7.

5 Constitution of a sample

5.1 General

Examples of the constitution of samples are shown in [Figure 1](#).

Primary increments shall be taken in accordance with the procedures specified in ISO 13909-5.

Individual increments are usually combined to form a sample. A single sample may be constituted by combination of increments taken from a complete sub-lot or by combining increments taken from individual parts of a sub-lot. Under some circumstances, e.g. size analysis or bias testing, the sample consists of a single increment which is prepared and tested.

Samples may also be prepared by the combination of other samples.

5.2 Combination of increments

The mass of the primary increments shall be proportional to the flow rate at the time of sampling. The primary increments may be combined into a sample, either directly as taken or after having been prepared individually to an appropriate stage by fixed-ratio division (see [Clause 6](#)).

5.3 Combination of samples

When combining samples, the mass of the individual samples shall be directly proportional to the mass of the coke from which they were taken in order to obtain a weighted mean of the quality characteristic for the sub-lot. Prior to combination, division shall be by fixed-ratio (see [Clause 6](#)).

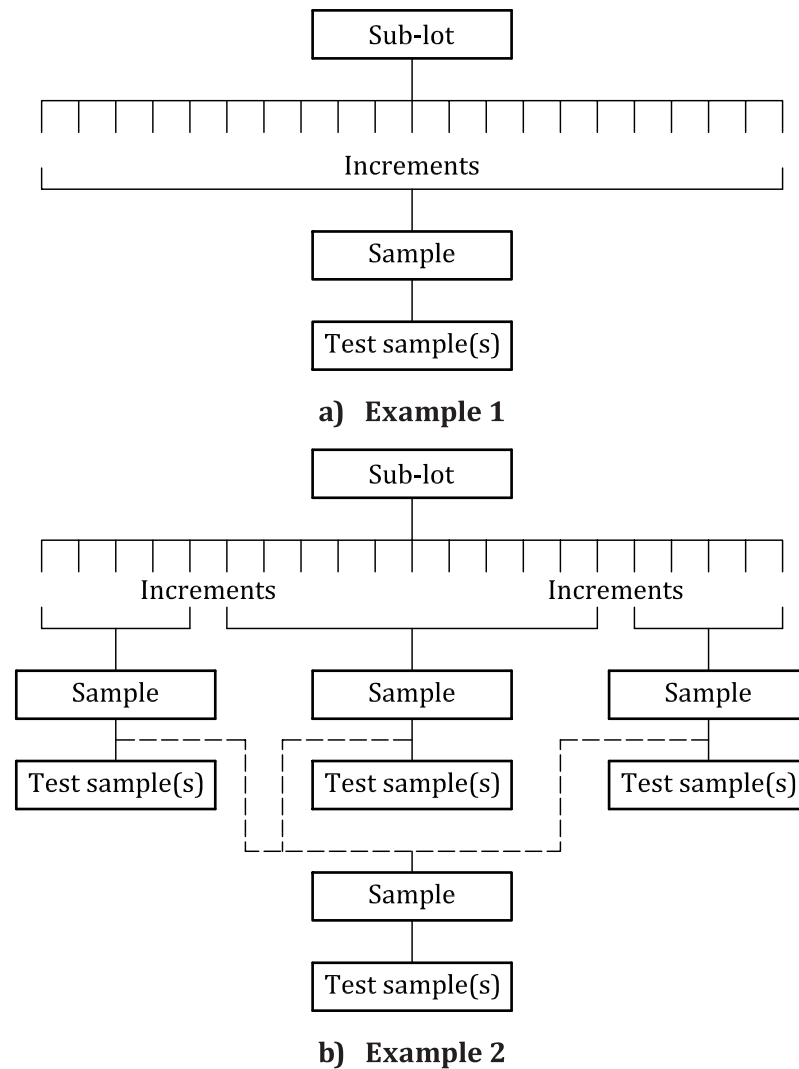

Figure 1 — Examples of the constitution of samples

6 Division

6.1 General

Since the cutter aperture will be at least three times the nominal top size, this will result in a very large increment mass in many cases. The handling and preparation of such large increments would be either manpower or equipment intensive. Division prior to further treatment may be necessary to provide a manageable sample mass.

Sample division can be

- on-line mechanically, or
- off-line mechanically or manually.

Whenever possible, mechanical methods are preferred to manual methods to minimize human error. Examples of dividers are shown in [Figure 2](#).

Mechanical dividers are designed to extract a part of the coke in a number of cuts of relatively small mass. When the smallest mass of the divided sample that can be obtained in one pass through the divider is greater than that required, further passes through the same divider or subsequent passes through further dividers may be necessary.

Manual division is normally applied when mechanical methods would result in loss of integrity (e.g. loss of moisture or size degradation). Manual division of coke is also applied when the nominal top size of the coke is such as to make the use of a mechanical divider impracticable. Manual methods may themselves result in bias, particularly if the mass of coke to be divided is large.

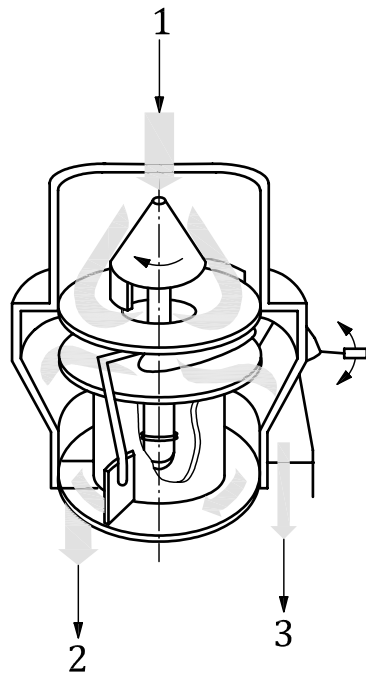

Key
 1 feed
 2 reject
 3 divided sample

The material from a mixing container is fed by scrapers to the centre of the dividing disc. From there, it is discharged over the range of the disc through special clearing arms. The sample falls through adjustable slots into chutes; the reject is carried away through a cleaning conduit. The whole interior space is cleaned by scrapers.

a) Rotating disc type

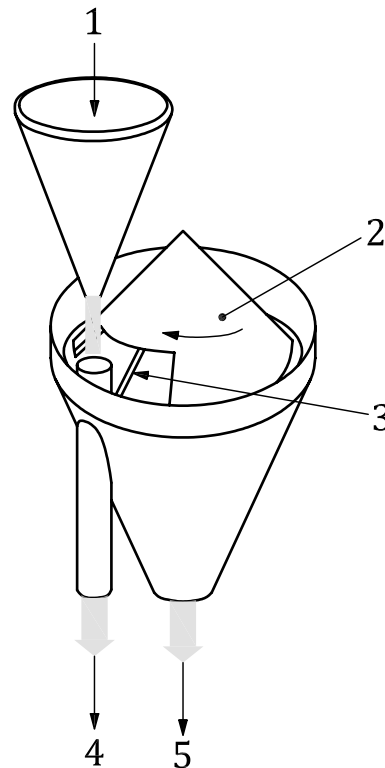

Key
 1 feed
 2 rotating cone
 3 adjustable slot
 4 divided sample
 5 reject

As stream of coal is allowed to fall onto a rotating cone; the adjustable slot with lips in the cone allows the stream to fall directly onto the sample receiver for part of each revolution.

b) Rotating cone type

Figure 2 — (continued)

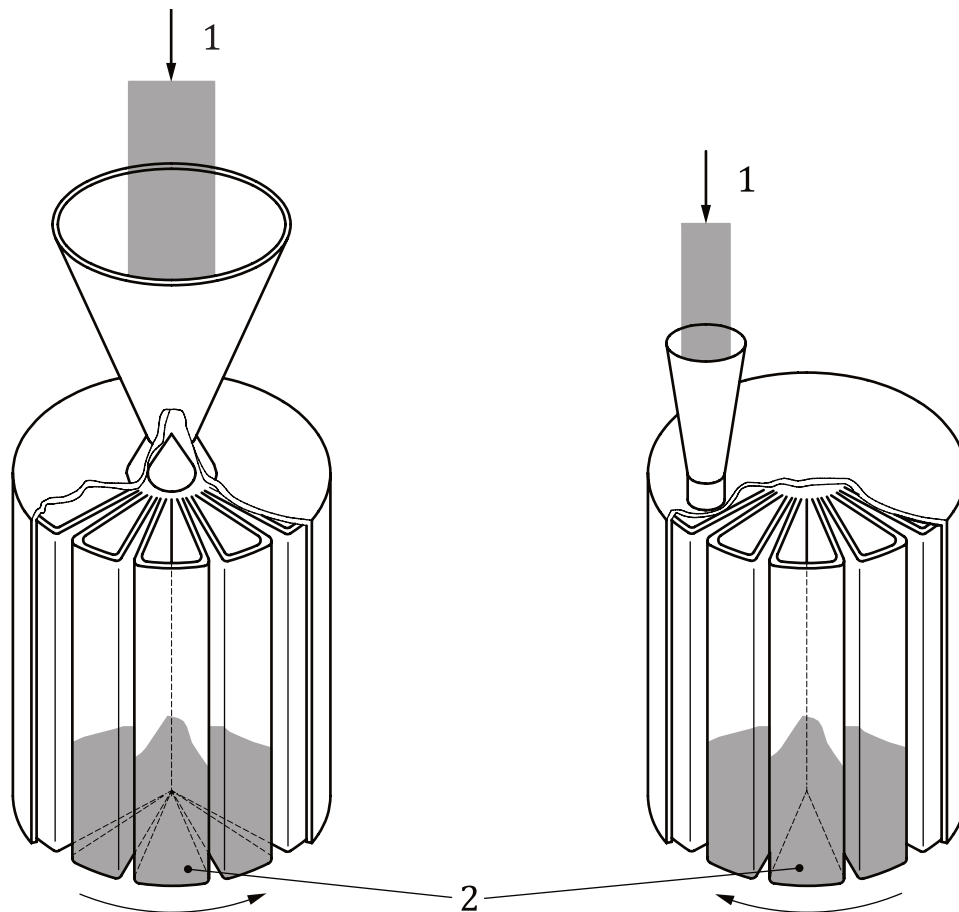

Key

- 1 feed
- 2 divided sample in rotating receivers

The coal stream flows to the hopper and this flow is intercepted by the top edge of a number of sector-shaped containers dividing the flow into equal parts. Either the hopper or the containers may rotate. The machine can be controlled for the following operations:

- a) for dividing;
- b) for collecting duplicates;
- c) for collecting replicates.

c) Container type

Figure 2 — (continued)

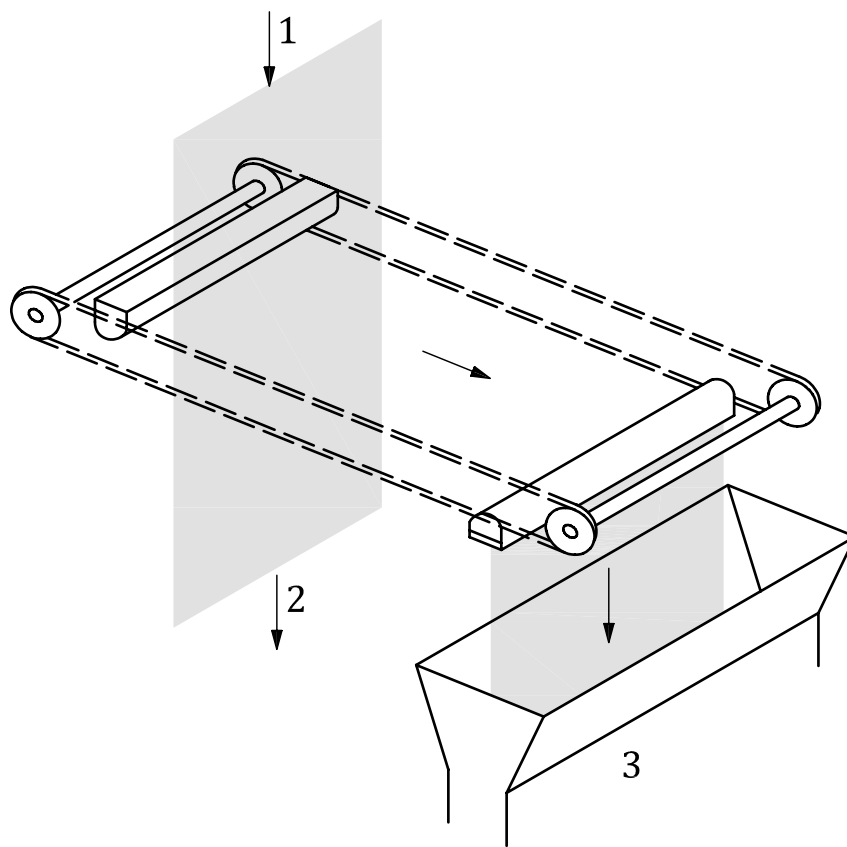

Key

- 1 feed
- 2 reject
- 3 divided sample

A chain mechanism as shown is equipped with buckets spread at equal pitch. The buckets travel in a single direction or change direction at preset time periods. The bucket intercepts the free-falling coal stream to extract cuts which discharge the sample as the bucket inverts.

d) Chain bucket type

Figure 2 — (continued)

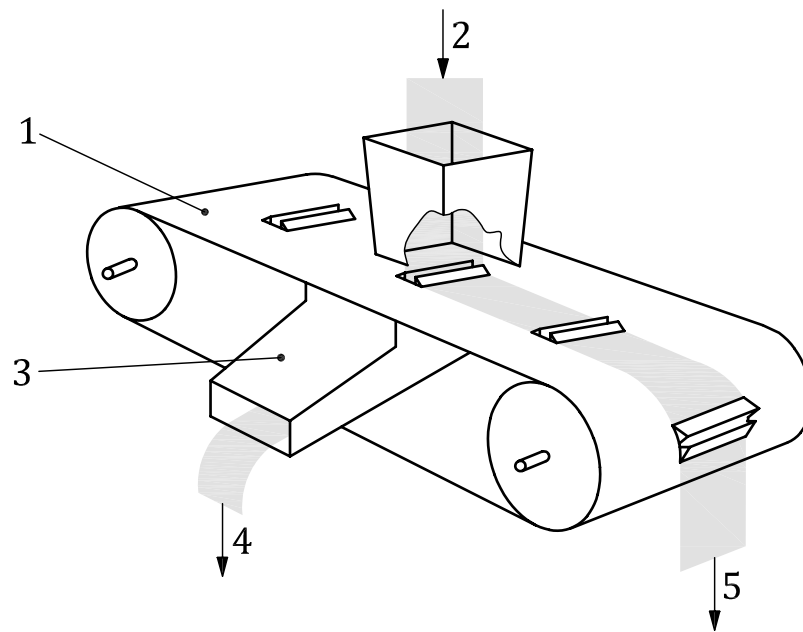

Key

- 1 slotted belt
- 2 feed
- 3 inclined chute
- 4 divided sample
- 5 reject

An endless belt as shown having slots spaced at equal pitch with lips that act as cutting edges passing below a feed chute. The coal stream is fed to the chute and, as each slot passes through the stream, a cut is taken. The stream which falls onto the plain part of the belt is carried to rejects.

e) Slotted-belt type

Figure 2 — (continued)

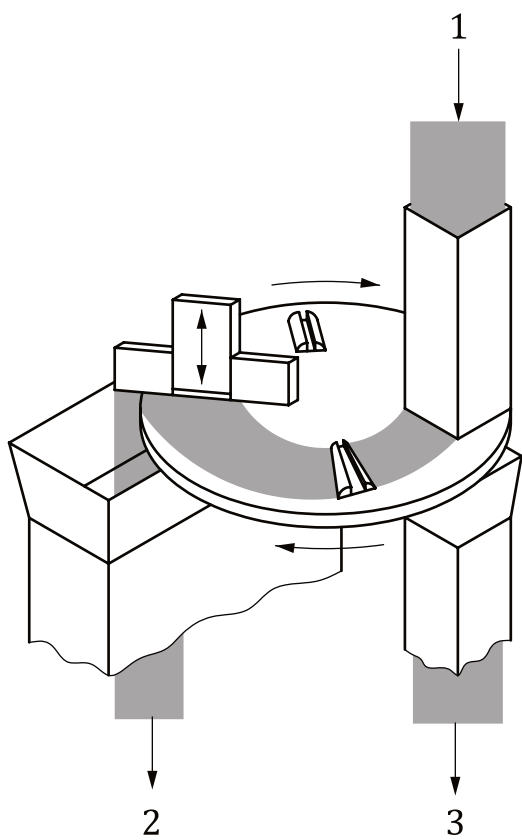

Key

- 1 feed
- 2 reject
- 3 divided sample

A flat plate with lipped slots spaced at equal pitch rotates beneath a feed chute. Coal is fed into the feed chute, then, falls onto the rotating plate to form a ribbon bed which is carried to the plough and discharged to rejects. As a slot passes through the stream, a cut is taken.

f) Rotating plate type

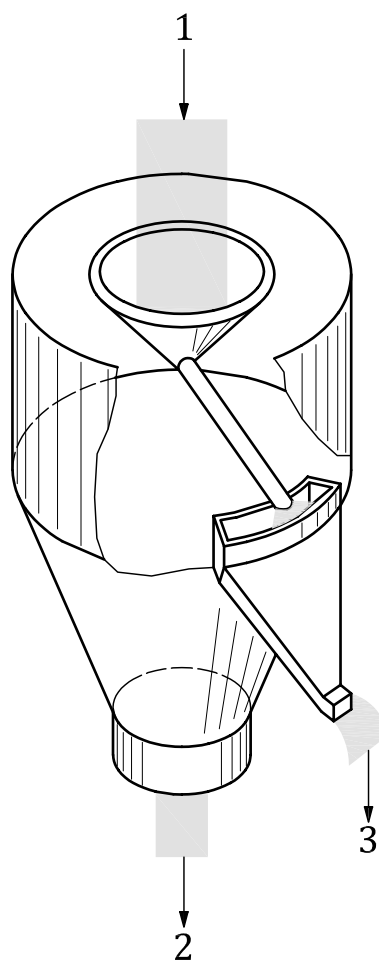

Key

- 1 feed
- 2 reject
- 3 divided sample

A hollow shaft with a rotating conical hopper and chute which distributes the coal to one or more stationary cutters within a housing as shown. Each cutter is designed to take cuts from the coal stream and the rejects are discharged through the hollow shaft.

g) Rotating chute type

Figure 2 — (continued)

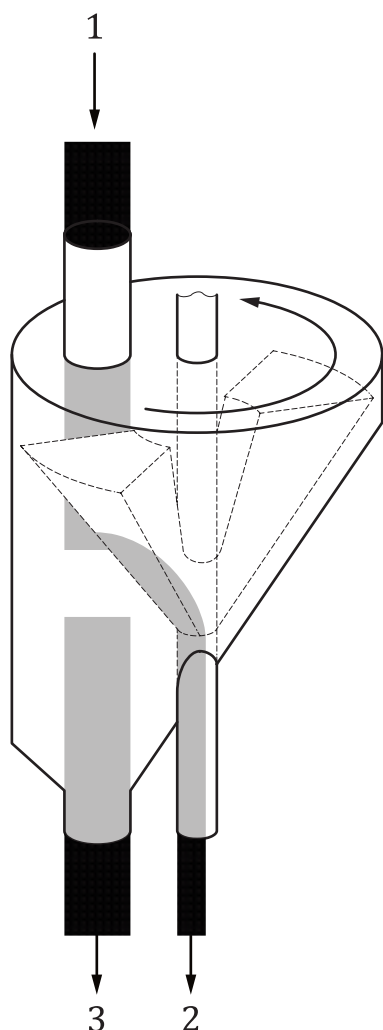
**Key**

- 1 feed
- 2 divided sample
- 3 reject

One or more rotating cutters take cuts from the coal stream as it is fed into the housing through a feed chute as shown. Coal not collected by the rotating cutters is directed to reject at the bottom of the housing.

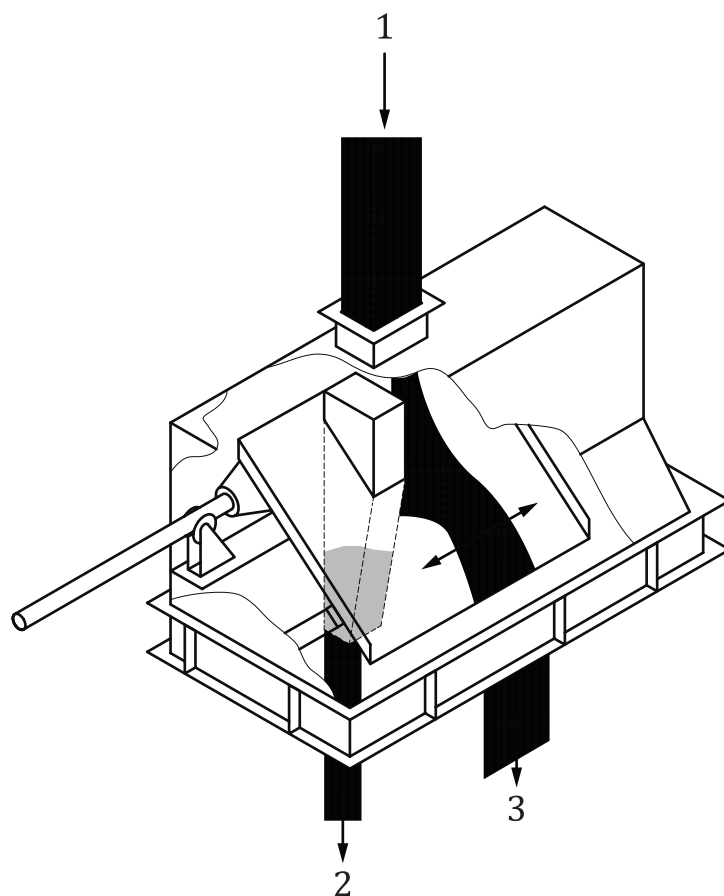
h) Rotating cutter type**Key**

- 1 feed
- 2 divided sample
- 3 reject

The cutter-chute traverses the full coal stream and diverts a portion from the stream. When the coal stream is not being cut by the chute, it is deflected by the angle plate to reject.

i) Cutter-chute type**Figure 2 — Examples of dividers****6.2 Mechanical methods****6.2.1 General**

Mechanical sample division may be carried out on an individual increment or a sample. Where samples are for moisture or general analysis, it is permissible to install on-line crushing to a nominal top size of

16 mm followed by sample division. Division shall be by fixed-ratio division subject to the conditions set out in [6.2.2](#) and [6.2.3](#).

When crushing on-line, the risk of moisture loss should be considered, particularly if the coke is hot.

The uses to which the sample is to be put, the numbers, masses and size distribution of the test samples required shall also be taken into account when deciding on the minimum mass of the sample.

When a coke is regularly sampled under the same conditions, the precision obtained for all the required quality parameters shall be checked using the procedures of ISO 13909-7 and the minimum mass adjusted accordingly. The masses shall not be reduced, however, below the minimum requirements laid down in the relevant analysis standards.

6.2.2 Mass of cut

The flow of coke to the divider shall be controlled so that the required number of cuts of approximately uniform mass can be taken throughout the division of an increment. The cutting aperture and speed of the cutter shall be constant. The method of feeding the divider shall be designed to minimize any segregation caused by the divider.

The cutting aperture shall be at least three times the nominal top size of the coke to be divided.

6.2.3 Interval between cuts

In order to minimize bias, the first cut for each mass to be divided shall be made at random within the first interval. For secondary and tertiary dividers, the cycle time shall not be evenly divisible into the cycle time of the cutter which precedes it.

The interval between taking cuts shall be constant, irrespective of the variations of masses of coke to be divided so that divided sample masses are proportional to the mass of the feed. The ratio shall be fixed for the whole sub-lot.

6.2.4 Division of individual increments

6.2.4.1 Number of cuts

When dividing an uncrushed increment, the minimum number of cuts from an increment of mean mass at any stage shall be four. If the divided increments are crushed, a minimum of one cut shall be taken from each cut from the preceding division.

6.2.5 Minimum mass of divided increment

The minimum mass of the divided increment shall be such that the combined masses of all the divided increments in the sub-lot shall, at each stage, be greater than the mass given in [Table 1](#), corresponding to the nominal top size. If the increment masses are too low to satisfy this requirement, the divided increment shall be crushed prior to further division.

For moisture samples, there is a restriction of 70 kg on the maximum mass of sample to be crushed at one time during off-line preparation.

NOTE The masses given in [Table 1](#) are for guidance on the minimum mass for unknown or heterogeneous cokes. While they can usually be reduced for the moisture sample, they may be inadequate for the determination of, for example, oversize to 1 % division precision, particularly on very large cokes.

Table 1 — Minimum mass of sample after division

Nominal top size mm	Minimum mass kg
>125	2 000
125	1 000
90	500
63	250
45	125
31,5	60
22,4	30
16,0	15
11,2	8
10,0	6
8,0	4
5,6	2
4	1

6.2.6 Division of samples

6.2.6.1 Number of cuts

The sample shall be divided by taking a minimum of 60 cuts.

NOTE If, during preparation, the sample is thoroughly mixed and it can be established that the required precision can be achieved, the number may be reduced, with a minimum of 20. The required precision is easier to achieve if the coke has been sized.

6.2.6.2 Minimum mass of divided sample

The mass of the divided sample shall not be less than the minimum mass in [Table 1](#).

6.3 Manual methods

6.3.1 General

For the manual division methods given in [6.3.2](#) to [6.3.4](#), the mass of the divided sample shall not be less than the minimum mass in [Table 1](#), subject to there being sufficient mass for all test portions required. For coke of all sizes, riffing and strip mixing are suitable procedures; however, the flattened-heap method can only be utilized for coke of less than 20 mm nominal top size.

6.3.2 Riffle method

A riffle (see [Figure 3](#)) is a sample divider that will, in a single pass of a sample, divide it into halves, one of which is retained and the other is normally rejected. The device is normally portable and, for sample division, is usually fed manually, the coke being evenly distributed along its length. Adjacent slots feed opposite receivers.

The slot width shall be at least three times the nominal top size of the coke. Each half of the riffle shall have the same number of slots, which shall be at least eight and preferably more. All the surfaces on which the coke might rest shall have a slope of at least 60° to the horizontal.

The coke shall be allowed to fall steadily into the riffle, ensuring that it is evenly distributed over all the slots. The coke shall be allowed to fall freely (i.e. not towards one side of the riffle) and the rate of feed shall be controlled such that the slots are never choked. Closed riffles are preferred.

Care shall be taken to minimize loss of dust and moisture. To this end, the receiver shall fit closely against the body of the riffle and for dry cokes and moisture samples, closed-type riffles shall be used.

When a stage of sample division requires two or more steps or passes, the sample retained at each step shall be taken alternately from each side of the riffle.

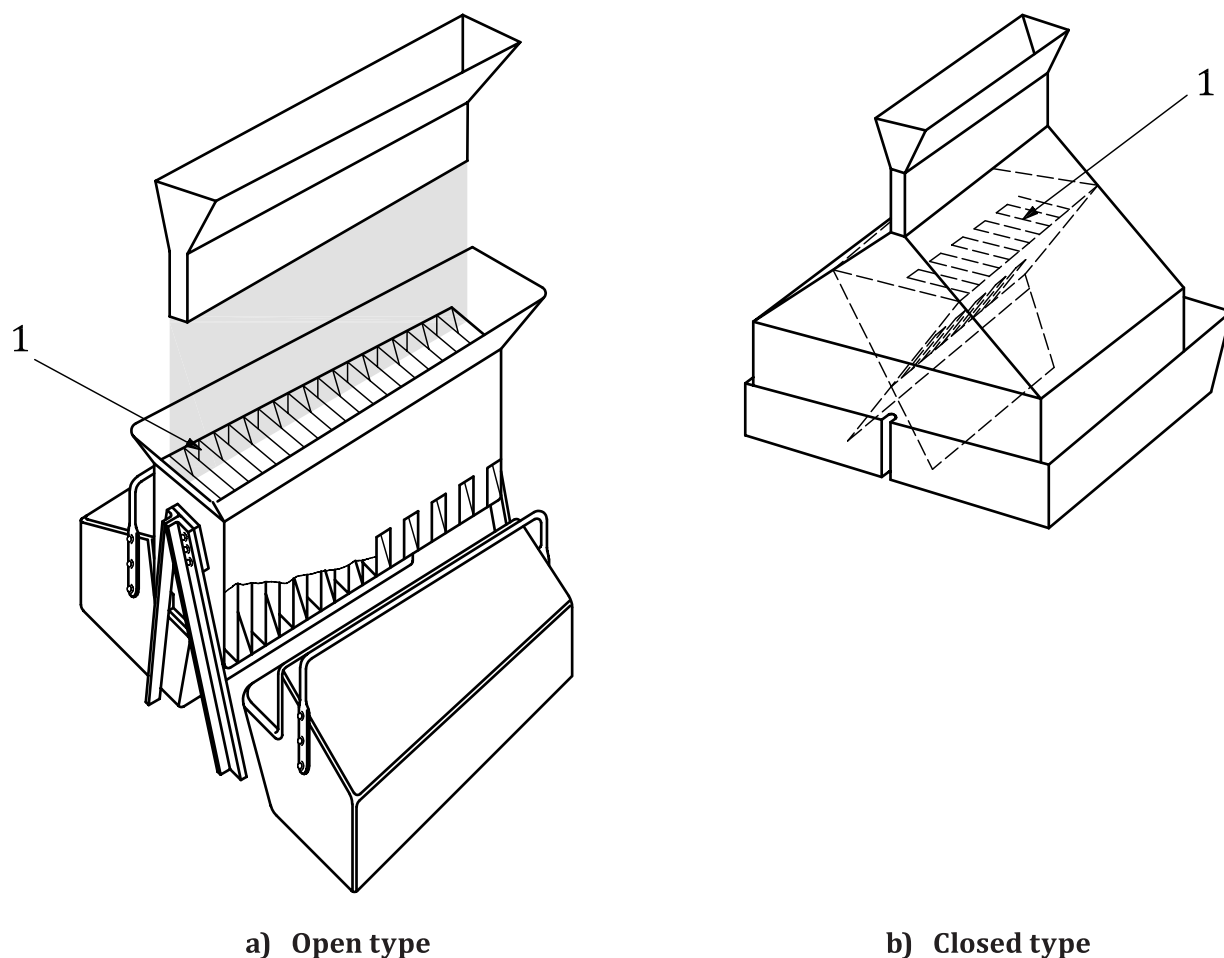
**Key**

1 even number of slots

Figure 3 — Examples of riffles

6.3.3 Flattened-heap method

The procedure, which is illustrated in [Figure 4](#), is as follows and is only suitable for coke of nominal top size less than 20 mm.

The sample is mixed thoroughly and spread to form a rectangle of uniform thickness of 40 mm to 50 mm on a mixing plate, which is a smooth, non-absorbent and non-contaminating surface. End plates shall be used to ensure that size segregation is minimized laterally.

Avoid moisture loss from wet cokes which can result from over-mixing.

A matrix is marked on the spread sample to give a minimum of 4×5 equal parts. An increment is taken, at random, from each of the parts by inserting a scoop with a bump plate (see the last paragraph of [6.3.3](#)) to the bottom of the matrix layer. The increments shall be combined into a divided sample. It is essential that these operations be performed quickly to prevent loss of moisture.

The increments shall be of uniform mass. The minimum mass required for each nominal top size of coke is the mass of the divided sample (see [Table 1](#)) divided by the number of parts of the flattened heap.

The scoop shall be flat bottomed and the width of the entry shall be three times the nominal top size of the coke; the side walls shall be higher than the height of the heap and the depth shall be sufficient to allow the required mass of increment to be taken.

Take the scoop sample with the aid of a bump plate which is inserted vertically through the flattened heap until it is in contact with the bottom of the sample layer. The scoop is then inserted to the bottom of the spread coke and moved horizontally until its open end comes into contact with the vertical bump plate. The scoop and bump plate are lifted together to ensure that all particles are collected off the top of the mixing plate and that none fall off during lifting.

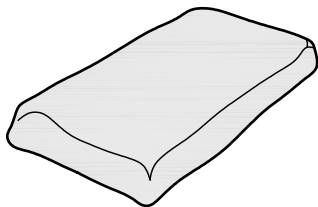

a) Spread the crushed sample into a rectangle with a maximum thickness of three times the nominal top size.

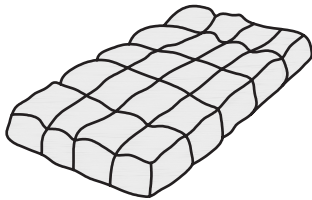

b) Arrange into 20 equal parts (e.g. into five equal parts lengthwise and four equal parts breadthwise).

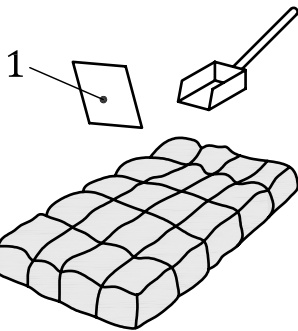

c) Take a scoopful of sample at random from each of the 20 parts by inserting the scoop to the bottom of the sample layer (see d) below). Combine the 20 scoopfuls to form the divided sample.

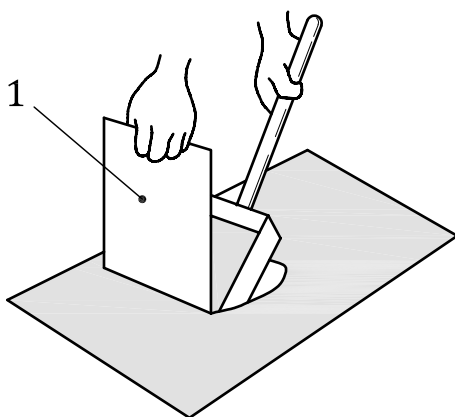

d) Detail of taking an increment by using the bump plate shown in c).

Key

1 bump plate

Figure 4 — Flattened-heap method

6.3.4 Strip-mixing and splitting method

The procedure, which is illustrated in [Figure 5](#), is as follows.

The coke sample is formed on a mixing plate, which is a smooth, non-absorbent, non-contaminating surface, into a strip at least 10 times as long as it is wide by distributing the coke along the length of the strip as evenly as possible, working randomly from end to end and from both sides of the strip. End plates shall be used to ensure that size segregation only occurs laterally.

Increments shall be taken as a complete section across the strip. The width of each cross-section shall be not less than three times the nominal top size of the coke.

NOTE 1 Special apparatus for the cutting out of increments may be constructed if desired.

Normally, 20 increments are required. Fewer increments may be taken, subject to a minimum of 10, where the same quality coke is regularly prepared under the same conditions and it has first been established that the required precision can be obtained (see ISO 13909-7).

NOTE 2 Because of the efficient longitudinal mixing achieved in the formation of a strip, the same precision as that obtainable with the flattened-heap method can be achieved with fewer increments.

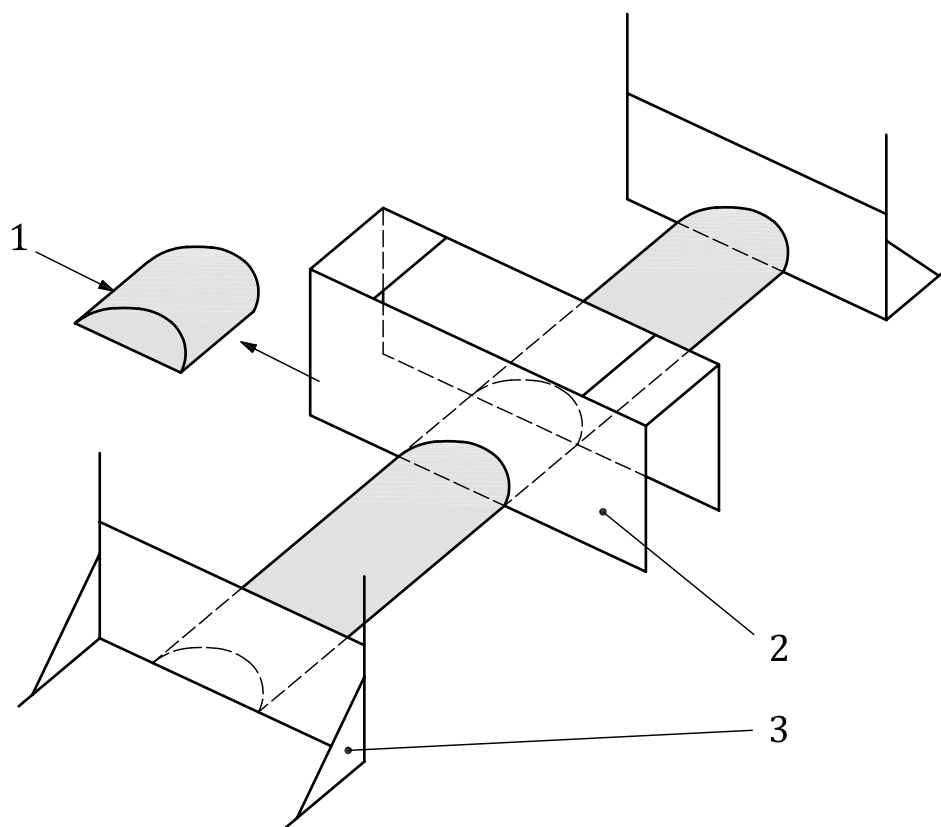

Key

- 1 increment
- 2 sampling frame
- 3 end plates ("book ends")

Figure 5 — Strip-mixing and splitting method

7 Preparation of samples for specific tests

7.1 Types of test sample

The methods of preparation depend on the purpose for which the original sample was collected. Three types of sample are usually required:

- a) sample for determination of total moisture content;
- b) sample for general analysis;
- c) sample for physical tests.

Additional samples may be required for testing for special properties. Where samples are to be used for the determination of other special properties, it will be necessary to set aside part of the sample, either prior to preparation or after an appropriate stage in the preparation.

A schematic diagram showing the alternative ways of constituting and preparing the various types of test sample is shown in [Figure 6](#).

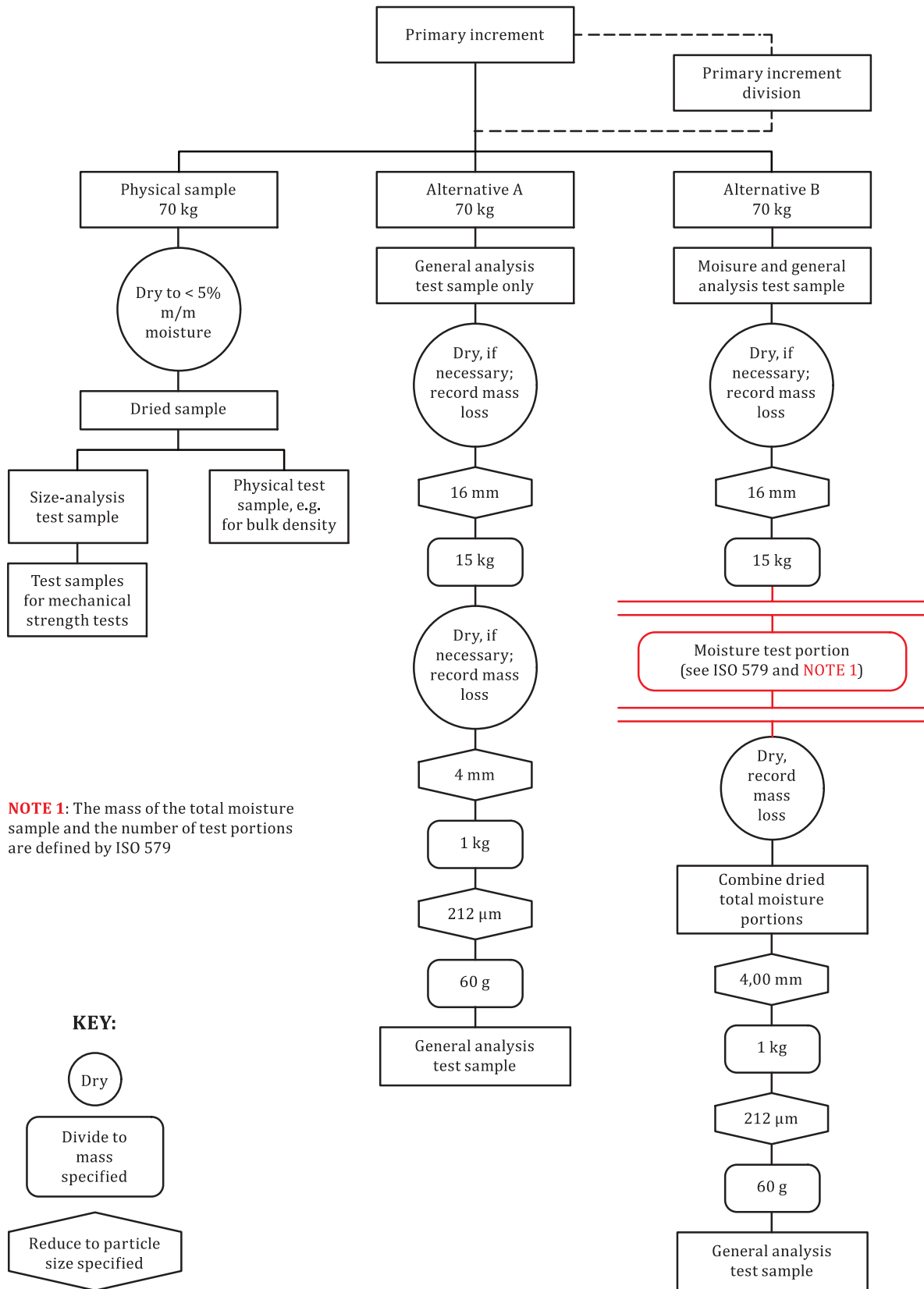

NOTE 1: The mass of the total moisture sample and the number of test portions are defined by ISO 579

NOTE The mass of the total moisture sample and the number of test portions are defined by ISO 579.

Figure 6 — Constitution and preparation of samples

7.2 Preparation of samples for determining total moisture

7.2.1 General

A major problem with the preparation of test samples for the determination of moisture content is the risk of bias due to inadvertent loss of moisture. The amount of this loss is dependent on such factors as the type of coke, the level of moisture content of the sample, the ambient conditions, the reduction and division procedures used and the effectiveness of the sealing of the sample containers. If excessive standing time causes bias, increase the number of sub-lots to overcome these problems (see ISO 13909-5).

The time taken for one sample reduction operation shall not exceed 15 min, otherwise the coke will be exposed for such a time that appreciable loss of moisture may occur. If the sample reduction takes longer, then the sample should be split into several subsamples. A total moisture test sample at -16 mm nominal top size is then prepared from each subsample and a total moisture result for each subsample is determined.

Care shall also be taken to minimize loss of moisture during division by carrying out the operation as quickly as possible either using rotary sampler dividers or closed riffles. A check on the sampling precision (ISO 13909-7) can be obtained if the subsamples are formed by placing successive increments in different containers.

All samples for moisture determination shall be kept in sealed containers in a cool place, under cover, before and during preparation as well as during any interval between steps of sample preparation. Precautions shall be taken to minimize loss of moisture due to the use of unsuitable containers and to evaporation during handling.

7.2.2 Procedure

The procedure for preparing the test sample for the determination of total moisture is shown schematically in [Figure 6](#).

In the case of small coke, having a top size of 16 mm or less, only the process of sample division described in [7.2.5](#) is required.

7.2.3 Wet samples

When the coke is so wet that there is moisture standing in the sample container, then an air-drying step is required prior to further reduction and preparation. The procedure for air-drying is stated below and indicated in [Figure 6](#) as “dry if necessary”.

The procedure for air-drying is as follows.

Weigh the whole of the sample in its container on a weighing machine which can be read to an accuracy of at least 100 g. Spread the sample in a thin layer on a steel plate in a warm, well-ventilated room and leave for a minimum of 12 h until there is no visible moisture on either the coke or the plate. Meanwhile, dry and weigh the container. Collect the air-dried sample in the original container and reweigh and calculate the percentage loss in mass. Continue the preparation according to [7.2.4](#) and [7.2.5](#).

When air-drying has been used, the percentage loss of moisture in this operation shall be recorded on the label with a reference to the method of sampling and preparation used.

After the moisture of the partially dried sample has been determined as described in [7.2.6](#), calculate the total moisture, M_T as a percentage, using [Formula \(2\)](#):

$$M_T = X + M \left(1 - \frac{X}{100} \right) \quad (2)$$

where

X is the percentage loss on partial drying;

M is the percentage of moisture determined as described in [7.2.6](#).

7.2.4 Reduction of total moisture test sample

The primary increments or divided primary increments shall be fed through a jaw crusher to reduce the nominal top size to 16 mm. The time taken to crush 50 kg shall not exceed 5 min. The process shall be timed occasionally to ensure that this time is not exceeded.

Care should be taken to avoid loss of moisture by undue ventilation or loss of sample as dust.

7.2.5 Division

A total moisture test sample shall be prepared by dividing the 16 mm sample to a mass of 15 kg using mechanical rotary sampler dividers as shown in [Figure 2 a](#)), b), c), g) and h) or manually using closed riffles.

If the coke being sampled is already -16.0 mm, the mass of the total moisture test sample shall be determined from the nominal top size of the coke and [Table 1](#). The procedure then starts at the division of moisture test portion stage in [Figure 6](#).

A divider may be installed so that the product of the crusher is discharged directly into the feed bin of the divider so that reduction and division may proceed concurrently. Precautions shall be taken against undue ventilation.

7.2.6 Determination of total moisture

The total moisture sample prepared as described in [7.2.2](#) to [7.2.5](#) shall be transferred to the laboratory in a closed container. For the determination of total moisture, a test portion is dried in duplicate by one of the methods specified in ISO 579 or ISO 687.

7.2.7 Reserve sample

If a second sample is needed as a reserve or check sample, duplicate moisture test samples shall be taken at the same time either by modifying the division procedure or by taking alternate increments when carrying out the procedure of mechanical or manual division.

7.3 Preparation of sample for general analysis

7.3.1 General

The procedure for the preparation of a test sample for general analysis is shown in schematic form as part of [Figure 6](#). For general analysis only, a test sample is prepared using Alternative A. Alternatively, the starting material may be the test portions combined from the total moisture test after drying as described in Alternative B of [Figure 6](#).

7.3.2 Preparation errors

7.3.2.1 Segregation errors

The segregation error arises from the heterogeneous nature of coke and because of the difficulty in uniformly mixing any coke in which there is a wide range of sizes. It is therefore essential to mix the coke thoroughly in order to obtain a representative sample.

7.3.3 Reduction

The dried analysis test samples ([Figure 6](#), Alternative A) or dried total moisture test portions ([Figure 6](#), Alternative B) shall be crushed to pass a 212 μm sieve with minimum fines using suitable mills. The materials in contact with the coke shall be of such hardness that contamination of the sample that occurs by abrasion is minimized.

NOTE Mills with tungsten carbide rings and bowl are most suitable.

For some methods of reduction to $-212 \mu\text{m}$, it may be necessary to reduce the coke from -16 mm to an intermediate size (e.g. -4 mm).

7.3.4 Division

Mechanical or manual division may be used. For mechanical division, a suitable divider to give 60 g of 212 μm coke is required. For manual division, a riffle may be used, or the sample may be spread out and 60 g is taken by hand in not less than 20 increments taken from various parts of the heap using a small-scale version of the technique described in [6.3.3](#).

7.3.5 Preparation errors

The process of sample preparation, which involves two distinct operations of reduction and division, may lead to errors due to contamination, segregation and loss of fines.

The contamination error arises from the abrasive nature of coke, which tends to wear the surface of mild steel, cast iron, porcelain and, if a rubbing action is involved, most of the surfaces used in grinding equipment. This error may be as high as 3 % of ash if the dried moisture sample is reduced to 212 μm by rubbing on a cast-iron surface.

Although contamination usually implies the presence in the ash of iron oxide derived from a ferrous grinding surface, it may also involve an increase in the phosphorus content if cast-iron surfaces are used.

The contamination error can never be entirely eliminated, but it can be reduced to negligible proportions if the recommended methods and equipment are used. Methods of size reduction other than those recommended, such as rubbing against a metal surface, are unsatisfactory and shall not be used.

7.4 Storage

The general analysis sample shall be well mixed and placed in an air-tight container for storage. A plastic or glass jar with a screw-on lid is suitable.

7.5 Physical test sample

The physical test sample may be used for the determination of size, physical characteristics or both. It is essential that collection and preparation procedures are such that breakage is minimized.

The sample may be divided to a mass not less than that given in [Table 1](#).

7.6 Samples for special properties

Samples required for special tests shall be extracted from an appropriate stage in the off-line or on-line preparation process and prepared to the size and mass specified in the relevant International Standard test method.

Tests which may be required in this context are Shatter Index^[3], Micum and Irsid Index^[1], reactivity tests^[7], density^{[2][5]} and size distribution^{[4][6]}.

Requirements concerning particle size, sample size and other factors in these International Standards should be taken into account in the preparation of the test sample if the International Standard is cited in the sampling protocol.

8 Design of equipment for preparation

8.1 Dividers

Division devices shall

- a) have sufficient capacity to retain completely or to pass the entire sample without loss or spillage,
- b) not introduce bias, for example, by selective collection (or rejection) by particle size,

NOTE In order to avoid moisture loss, in some circumstances totally enclosed dividers may be necessary.

- c) use a method of feeding which minimizes the segregation of the coke,
- d) provide a controlled uniform flow to the equipment at each stage of division, and
- e) in the case of on-line mechanical dividers, have cutting frequencies which are not in phase with the preceding equipment.

NOTE It is desirable that the equipment be able to provide a random start within the first sampling interval for the first cut on each mass of coke to be divided in order to minimize bias.

8.2 Design of cutters for falling-stream dividers

8.2.1 General

A cutter intended for dividing a falling stream of coke shall be designed to meet the following requirements in addition to those specified in [8.1](#).

- a) The cutter shall take a complete cross-section of the stream.
- b) The leading and trailing cutting edges shall describe the same plane or the same cylindrical surface, as appropriate, and this plane or surface shall preferably be normal to the mean trajectory of the stream.
- c) The cutter shall travel through the coke stream at a uniform velocity, i.e. the velocity shall not deviate by more than 5 % from the preselected reference velocity at any point.
- d) The design of the cutter aperture shall be such that all parts of the stream are exposed to the aperture for the same length of time.
- e) The effective capacity of the sampling cutter shall be such that, at the expected maximum flow rate of the coke stream, it will retain or pass the whole of the increment without loss or spillage and without any part of the cutter becoming blocked or restricted by material already collected.
- f) The width of the cutter aperture shall be at least three times the nominal top size of the coke. When the coke is wet and is likely to bridge, the cutter aperture shall be at least 30 mm. If the cutter aperture is tapered, as is the case with some swing-arm-type samplers, the minimum width requirement shall apply to the width at the narrow end.

8.2.2 Cutter velocity

The width of the cutter aperture and the cutter velocity are important parameters to be considered when designing a sample cutter. Taken jointly with the velocity of the coke stream, these parameters will determine the effective width of the cutter aperture (i.e. the width of that part of the aperture into which the stream of coke can flow unimpeded).

For falling-stream cutters, experimental work on ores^[8] has shown that for sampling heterogeneous material streams of low belt loading, where particle size distribution is very narrow, bias may be introduced when the cutter speed exceeds 0,6 m/s or the cutter aperture is less than three times the nominal top size of the material.

The ratio of the effective cutter width to nominal top size of the coke will decisively influence the capability of the cutter to take unbiased increments since the greater this ratio is, the less will the tendency be to selectively reject the larger particles.

On the basis of this evidence, cutters that have a cutter aperture width, b , equal to three times the nominal top size of the coke shall not exceed a cutter speed of 0,6 m/s.

For cutters where the aperture is in excess of three times the nominal top size, the maximum cutter speed, v_c , can be increased in accordance with the [Formula \(3\)](#), subject to a maximum speed of 1,5 m/s:

$$v_c = 0,3 \left(1 + \frac{b}{3d} \right) \quad (3)$$

where

b is the cutter aperture width, in millimetres;

d is the nominal top size of the coke, in millimetres.

Irrespective of cutter speed and aperture, the cutter shall be shown to be capable of collecting unbiased increments.

8.3 Crushers

8.3.1 General

Crushers shall be capable of producing a product which has a nominal top size appropriate to the next stage of division. Examples are given in [8.3.2](#).

8.3.2 Examples of crushers

8.3.2.1 Jaw crusher, having replaceable serrated jaws made of manganese steel or chilled cast iron, capable of dealing with the largest size of coke to be crushed and capable of crushing wet coke to pass 16 mm at a rate of 50 kg in 5 min.

8.3.2.2 Crushing rolls, consisting of two rolls, 200 mm in diameter, made of chromium steel, each being operated at 2,5 Hz. The gap between the rolls or the pressure on them is controlled. The equipment shall be kept in an atmosphere with a relative humidity of less than 80 %. After continuous use for a long period, the rolls may wear and shall be reground if the gap in the centre exceeds 1,5 mm when the edges are in contact.

8.3.2.3 Rotating crushers, several types of rotating crushers, such as ring grinders and planetary ball mills, operate by crushing or shattering the coke rather than by grinding. Provided that the metal surfaces in contact with the coke are abrasion resistant, for example tungsten carbide, such mills can be used for the final stage of crushing to $-212 \mu\text{m}$. The ash content of the product shall be tested for bias against samples prepared by the crushing rolls using methods given in ISO 13909-8.

8.4 Preparation systems

8.4.1 General

Ideally, the mechanical system shall be designed at the same time as the coke-handling plant. In that event, the main plant can be designed to accommodate the mechanical sampler and the best practicable conditions for its operation can be ensured. However, even if the sampler is added to an existing plant, it is essential that engineering expediency is not allowed to cause any condition which would make the system biased.

The design of the system for sample preparation is related to the types of coke to be handled, the quality characteristics to be determined and the maximum number, mass and frequency of increments anticipated are discussed in [Clause 6](#).

The procedure adopted shall be such that bias is kept to a minimum during either the taking of the increments or the subsequent sample preparation. The system may be designed to produce any of the following samples:

- a) a common sample of uncrushed coke;
- b) a physical sample of uncrushed coke;
- c) a moisture sample of uncrushed coke;
- d) a crushed sample of –16 mm particle size for moisture or general analysis.

8.4.2 Design criteria

The system shall be designed and engineered in such a way that

- a) it is capable of preparing samples that are unbiased and which satisfy the requirements for precision,
- b) it can maintain this capability under all conditions of sampling that are stipulated in the relevant specifications and without necessitating interruption of preparation for cleaning or maintenance,
- c) due consideration is given to the safety of the operation from the initial stages of design and construction and all safety codes applicable at the site where the equipment is to be installed are respected,
- d) it is sufficiently robust to withstand adverse operating conditions,
- e) the system as a whole, including dividers, chutes, hoppers, feeders, crushers and other equipment, can operate in a manner that facilitates material flow and minimizes the need for cleaning to prevent and clear blockages,
- f) any contamination of the sample (e.g. by material retained from an earlier sample) is avoided,
- g) degradation of the constituent particles is minimized if a sample is taken for particle-size determination, and
- h) any change in moisture content, chemical or physical properties, or loss of fine coke (e.g. due to air flow through the equipment) is minimized.

8.4.3 Normal operation

It is essential that any mechanical sampling system be maintained and operated as per criteria set out in ISO 21398.

8.4.4 Abnormal operation

A mechanical system shall be designed to ensure a sufficient degree of operating flexibility such that even under abnormal conditions, for instance when part or parts of the system are disabled due to breakdown or because they have become choked, the remainder of the system (assisted if necessary by suitable off-line preparation) is still capable of performing satisfactorily.

8.4.5 Provision for checking for precision

The sampling system shall be capable of processing the increments to constitute duplicate or replicate samples. Procedures for checking precision by means of duplicate and replicate sample preparation are described in ISO 13909-7.

8.4.6 Provision for testing for bias

Testing for bias should be conducted in accordance with ISO 13909-8. Provision shall be made for reference samples to be taken.

Bibliography

- [1] ISO 556, *Coke (greater than 20 mm in size) — Determination of mechanical strength*
- [2] ISO 567, *Coke — Determination of bulk density in a small container*
- [3] ISO 616, *Coke — Determination of shatter indices*
- [4] ISO 728, *Coke (nominal top size greater than 20 mm) — Size analysis by sieving*
- [5] ISO 1013, *Coke — Determination of bulk density in a large container*
- [6] ISO 2325, *Coke — Size analysis (Nominal top size 20 mm or less)*
- [7] ISO 18894, *Coke — Determination of coke reactivity index (CRI) and coke strength after reaction (CSR)*
- [8] Gy P.M. *Sampling of Heterogeneous and Dynamic Material Systems*. Elsevier Scientific Publishing, Amsterdam, 1992

