**Hard coal and coke — Mechanical
sampling —**

Part 4:
Coal — Preparation of test samples

Houille et coke — Échantillonnage mécanique —

Partie 4: Charbon — Préparation des échantillons pour essai



COPYRIGHT PROTECTED DOCUMENT

© ISO 2016, Published in Switzerland

All rights reserved. Unless otherwise specified, no part of this publication may be reproduced or utilized otherwise in any form or by any means, electronic or mechanical, including photocopying, or posting on the internet or an intranet, without prior written permission. Permission can be requested from either ISO at the address below or ISO's member body in the country of the requester.

ISO copyright office
Ch. de Blandonnet 8 • CP 401
CH-1214 Vernier, Geneva, Switzerland
Tel. +41 22 749 01 11
Fax +41 22 749 09 47
copyright@iso.org
www.iso.org

Contents

	Page
Foreword	v
Introduction	vi
1 Scope	1
2 Normative references	1
3 Terms and definitions	1
4 Precision of sample preparation	1
5 Constitution of a sample	2
5.1 Introduction.....	2
5.2 Combination of increments.....	2
5.2.1 Time-basis sampling.....	2
5.2.2 Mass-basis sampling.....	2
5.3 Combination of samples.....	3
6 Division	3
6.1 General.....	3
6.2 Mechanical methods.....	10
6.2.1 General.....	10
6.2.2 Mass of cut.....	10
6.2.3 Interval between cuts.....	10
6.2.4 Division of individual increments.....	10
6.2.5 Division of samples.....	13
6.3 Manual methods.....	14
6.3.1 Riffle method.....	14
6.3.2 Flattened-heap method.....	15
6.3.3 Strip-mixing and splitting method.....	17
7 Reduction	19
7.1 General.....	19
7.2 Reduction mills.....	19
8 Mixing	19
9 Air-drying	19
10 Preparation of samples for specific tests	20
10.1 Types of test samples.....	20
10.2 Preparation of samples for determination of total moisture only.....	20
10.2.1 General.....	20
10.2.2 Storage.....	22
10.2.3 Sample reduction.....	22
10.2.4 Sample division.....	23
10.3 Preparation of samples for general analysis only.....	23
10.3.1 General.....	23
10.3.2 Air-drying.....	23
10.3.3 Reduction and division.....	23
10.4 Common samples.....	24
10.4.1 General.....	24
10.4.2 Extraction of moisture sample by mechanical division.....	25
10.4.3 Extraction of moisture sample by manual method.....	25
10.5 Preparation of size-analysis sample.....	26
10.6 Preparation of samples for other tests.....	27
11 Reserve sample	28
12 Design of equipment for preparation	28
12.1 Dividers.....	28

12.2	Design of cutters for falling-stream dividers	28
12.2.1	General.....	28
12.2.2	Cutter velocity.....	29
12.3	Preparation systems.....	29
12.3.1	General.....	29
12.3.2	Design criteria.....	29
12.3.3	Abnormal operation.....	30
12.4	Provision for checking for precision	30
12.5	Provision for testing for bias.....	30
Bibliography	31

Foreword

ISO (the International Organization for Standardization) is a worldwide federation of national standards bodies (ISO member bodies). The work of preparing International Standards is normally carried out through ISO technical committees. Each member body interested in a subject for which a technical committee has been established has the right to be represented on that committee. International organizations, governmental and non-governmental, in liaison with ISO, also take part in the work. ISO collaborates closely with the International Electrotechnical Commission (IEC) on all matters of electrotechnical standardization.

The procedures used to develop this document and those intended for its further maintenance are described in the ISO/IEC Directives, Part 1. In particular the different approval criteria needed for the different types of ISO documents should be noted. This document was drafted in accordance with the editorial rules of the ISO/IEC Directives, Part 2 (see www.iso.org/directives).

Attention is drawn to the possibility that some of the elements of this document may be the subject of patent rights. ISO shall not be held responsible for identifying any or all such patent rights. Details of any patent rights identified during the development of the document will be in the Introduction and/or on the ISO list of patent declarations received (see www.iso.org/patents).

Any trade name used in this document is information given for the convenience of users and does not constitute an endorsement.

For an explanation on the meaning of ISO specific terms and expressions related to conformity assessment, as well as information about ISO's adherence to the WTO principles in the Technical Barriers to Trade (TBT), see the following URL: [Foreword — Supplementary information](#).

The committee responsible for this document is ISO/TC 27, *Solid mineral fuels*, Subcommittee SC 4, *Sampling*.

This second edition cancels and replaces the first edition (ISO 13909-4:2001), which has been technically revised.

ISO 13909 consists of the following parts, under the general title *Hard coal and coke — Mechanical sampling*:

- *Part 1: General introduction*
- *Part 2: Coal — Sampling from moving streams*
- *Part 3: Coal — Sampling from stationary lots*
- *Part 4: Coal — Preparation of test samples*
- *Part 5: Coke — Sampling from moving streams*
- *Part 6: Coke — Preparation of test samples*
- *Part 7: Methods for determining the precision of sampling, sample preparation and testing*
- *Part 8: Methods of testing for bias*

Introduction

The objective of sample preparation is to prepare one or more test samples from the primary increments for subsequent analysis. The requisite mass and particle size of the test sample depend on the test to be carried out.

The process of sample preparation may involve constitution of samples, reduction, division, mixing and drying, or all or a combination of these.

Primary increments may be prepared individually as test samples or combined to constitute samples either as taken or after having been prepared by reduction and/or division. Samples may either be prepared individually as test samples or combined on a weighted basis to constitute a further sample.

When difficulty in handling the coal or coals being sampled is expected at a particular stage in sample preparation, or if there is a likelihood of losing moisture by evaporation, it is necessary to withdraw the sample or increment from the on-line system at the stage immediately prior to the point of difficulty and proceed off-line.

Hard coal and coke — Mechanical sampling —

Part 4: Coal — Preparation of test samples

1 Scope

This part of ISO 13909 describes the preparation of samples of coal from the combination of primary increments to the preparation of samples for specific tests.

2 Normative references

The following documents, in whole or in part, are normatively referenced in this document and are indispensable for its application. For dated references, only the edition cited applies. For undated references, the latest edition of the referenced document (including any amendments) applies.

ISO 589, *Hard coal — Determination of total moisture*

ISO 3310-1, *Test sieves — Technical requirements and testing — Part 1: Test sieves of metal wire cloth*

ISO 13909-1, *Hard coal and coke — Mechanical sampling — Part 1: General introduction*

ISO 13909-2, *Hard coal and coke — Mechanical sampling — Part 2: Coal — Sampling from moving streams*

ISO 13909-3, *Hard coal and coke — Mechanical sampling — Part 3: Coal — Sampling from stationary lots*

ISO 13909-7, *Hard coal and coke — Mechanical sampling — Part 7: Methods for determining the precision of sampling, sample preparation and testing*

ISO 13909-8, *Hard coal and coke — Mechanical sampling — Part 8: Methods of testing for bias*

3 Terms and definitions

For the purposes of this document, the terms and definitions given in ISO 13909-1 apply.

4 Precision of sample preparation

From the equations given in ISO 13909-7, the estimated absolute value of the precision of the result obtained for the lot at the 95 % confidence level, P_L , for sampling is given by [Formula \(1\)](#):

$$P_L = 2\sqrt{\frac{V_I + V_{PT}}{n}} \quad m \quad (1)$$

where

- P_L is the estimated overall precision of sampling, sample preparation and testing for the lot at a 95 % confidence level, expressed as a percentage absolute;
- V_I is the primary increment variance;
- V_{PT} is the preparation and testing variance for both off-line and on-line systems;
- n is the number of increments to be taken from a sub-lot;
- m is the number of sub-lots in the lot.

The procedures given in this part of ISO 13909 are designed to achieve levels of V_{PT} of 0,2 or less for both ash and moisture tests. Better levels are expected when using mechanical dividers.

For some preparation schemes, however, practical restrictions may prevent the preparation and testing variance being as low as this. Under these circumstances, the user should decide whether to achieve the desired overall precision by improving the preparation scheme or by dividing the lot into a greater number of sub-lots.

The errors occurring in the various stages of preparation and analysis, expressed in terms of variance, may be checked by the method given in ISO 13909-7.

5 Constitution of a sample

5.1 Introduction

Primary increments shall be taken in accordance with the procedures specified in ISO 13909-2 and ISO 13909-3.

Individual increments are usually combined to form a sample. A single sample may be constituted by combination of increments taken from a complete sub-lot or by combining increments taken from individual parts of a sub-lot. Under some circumstances, e.g. size analysis or bias testing, the sample consists of a single increment which is prepared and tested. Examples of the constitution of samples are shown in [Figure 1](#).

The procedures for increment combination ([5.2](#)) may vary according to whether the primary increments were taken using a time-basis ([5.2.1](#)) or a mass-basis ([5.2.2](#)) sampling scheme.

Samples may also be prepared by the combination of other samples (see [5.3](#)).

5.2 Combination of increments

5.2.1 Time-basis sampling

The mass of the primary increments shall be proportional to the flow rate at the time of sampling. The primary increments may be combined into a sample either directly as taken or after having been prepared individually to an appropriate stage by fixed-ratio division (see [Clause 6](#)).

5.2.2 Mass-basis sampling

If the primary increments are of almost uniform mass (see note), they may be combined into a sample, either directly as taken or after having been prepared individually to an appropriate stage by fixed-ratio division (see [Clause 6](#)).

NOTE Almost uniform mass has been achieved if the coefficient of variation of the increment masses is less than 20 % and there is no significant correlation between the flow rate at the time of taking the increment and the mass of the increment (see ISO 13909-2:2016, Annex A).

If the primary increments are not of almost uniform mass, they may only be combined into samples after having been divided individually by fixed-mass division (see [Clause 6](#)).

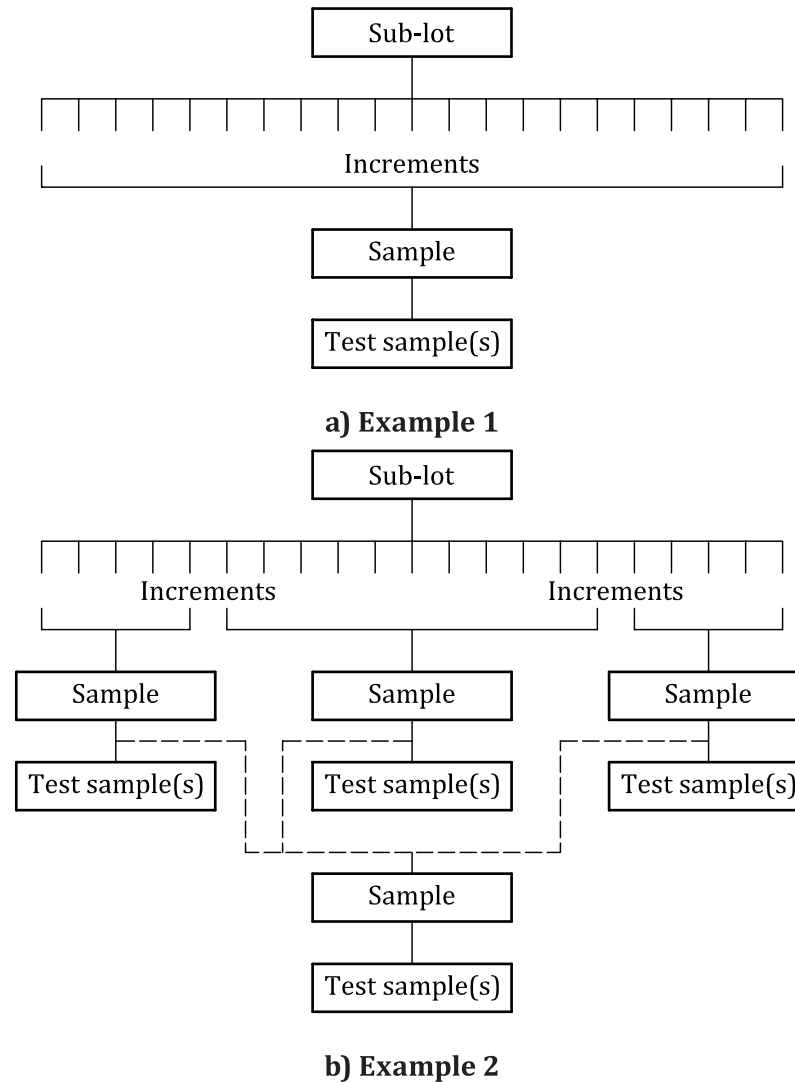

Figure 1 — Examples of the constitution of samples

5.3 Combination of samples

When combining samples, the mass of the individual samples shall be directly proportional to the mass of the coal from which they were taken in order to obtain a weighted mean of the quality characteristic for the sub-lot. Prior to combination, division shall be by fixed-ratio division (see [Clause 6](#)).

6 Division

6.1 General

Division can be

- on-line mechanically, or
- off-line mechanically or manually.

Whenever possible, mechanical methods are preferred to manual methods to minimize human error. Examples of dividers are shown in [Figure 2](#).

Mechanical dividers are designed to extract one or more parts of the coal in a number of cuts of relatively small mass. When the smallest mass of the divided sample that can be obtained in one pass through the divider is greater than that required further passes through the same divider or subsequent passes through further dividers may be necessary.

If coal does not run freely through a sample divider it may be necessary to air-dry the sample as described in [Clause 10](#) before sample division is undertaken.

Manual division is normally applied when mechanical methods would result in loss of integrity, e.g. loss of moisture or size degradation. Manual methods may themselves result in bias, particularly if the mass of coal to be divided is large.

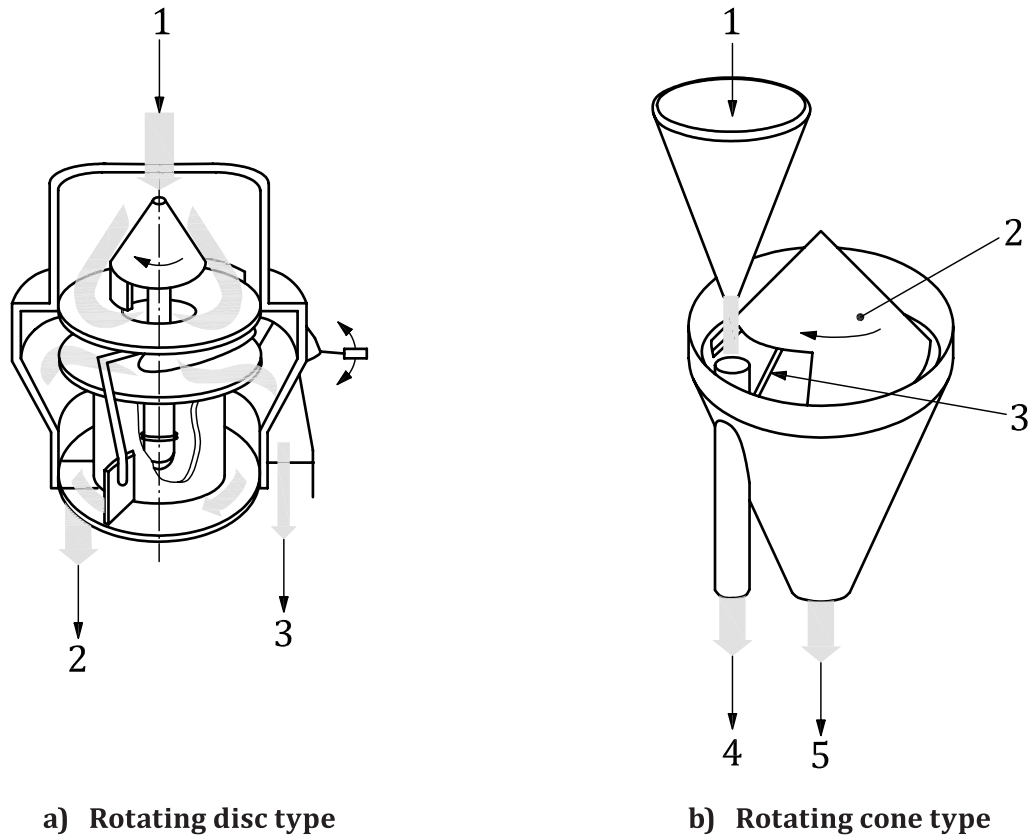

Key
 1 feed
 2 reject
 3 divided sample

The material from a mixing container is fed by scrapers to the centre of the dividing disc. From there it is discharged over the range of the disc through special clearing arms. The sample falls through adjustable slots into chutes; the reject is carried away through a cleaning conduit. The whole interior space is cleaned by scrapers.

Key
 1 feed
 2 rotating cone
 3 adjustable slot
 4 divided sample
 5 reject

A stream of coal is allowed to fall onto a rotating cone; the adjustable slot with lips in the cone allows the stream to fall directly onto the sample receiver for part of each revolution.

Figure 2 — Examples of dividers

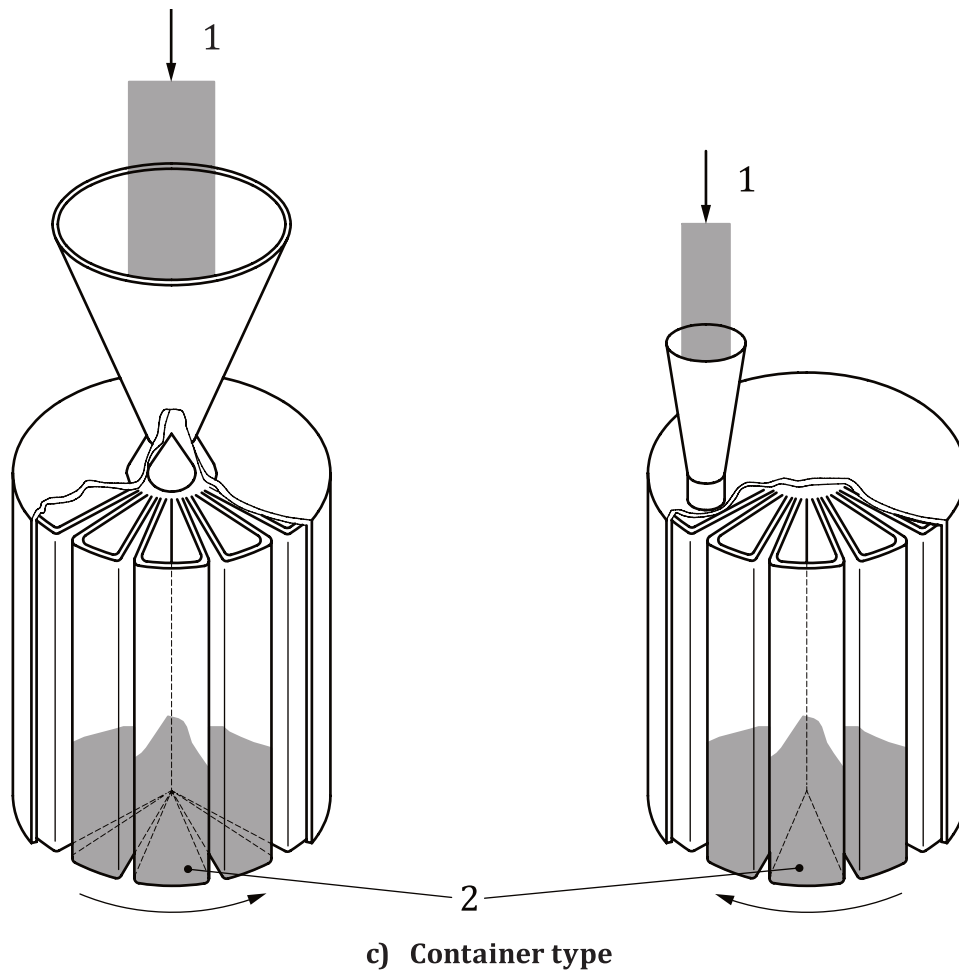
**Key**

- 1 feed
- 2 divided sample in rotating receivers

The coal stream flows to the hopper and this flow is intercepted by the top edge of a number of sector-shaped containers dividing the flow into equal parts. Either the hopper or the containers may rotate. The machine can be controlled for the following operations:

- 1) for dividing;
- 2) for collecting duplicates;
- 3) for collecting replicates.

Figure 2 — Examples of dividers (continued)

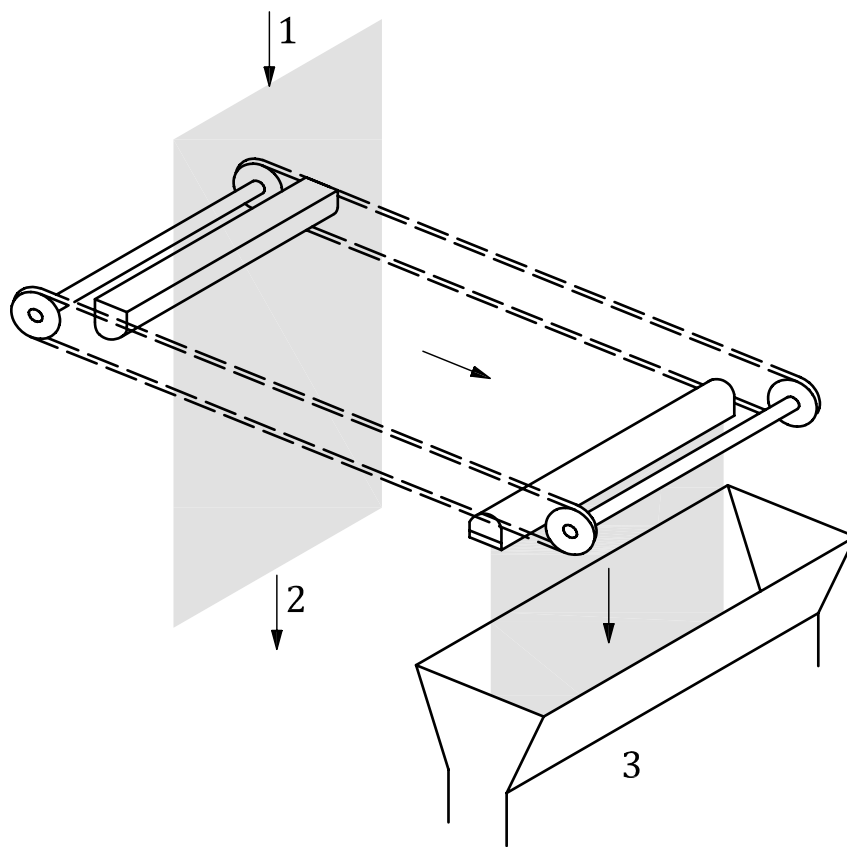

d) Chain bucket type

Key

- 1 feed
- 2 reject
- 3 divided sample

A chain mechanism as shown is equipped with buckets spread at equal pitch. The buckets travel in a single direction or change direction at preset time periods. The bucket intercepts the free-falling coal stream to extract cuts which discharge to sample as the bucket inverts.

Figure 2 — Examples of dividers (continued)

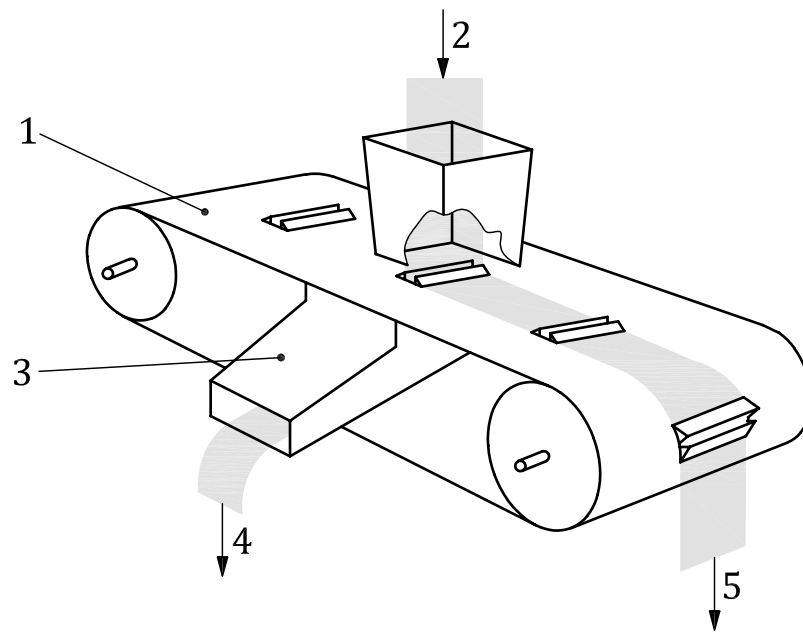

e) Slotted-belt type

Key

- 1 slotted belt
- 2 feed
- 3 inclined chute
- 4 divided sample
- 5 reject

An endless belt as shown having slots spaced at equal pitch with lips that act as cutting edges passing below a feed chute. The coal stream is fed to the chute and, as each slot passes through the stream, a cut is taken. The stream which falls onto the plain part of the belt is carried to rejects.

Figure 2 — Examples of dividers *(continued)*

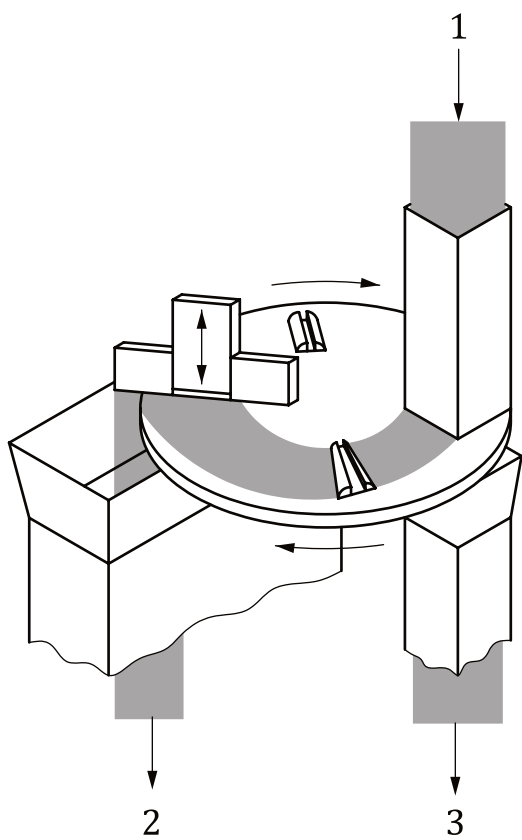

f) Rotating plate type

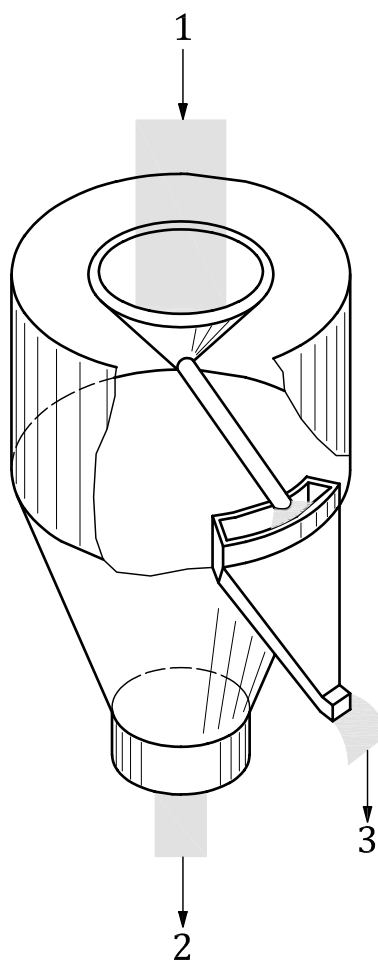

g) Rotating chute type

Key

- 1 feed
- 2 reject
- 3 divided sample

A flat plate with lipped slots spaced at equal pitch rotates beneath a feed chute. Coal is fed into the feed chute, then, falls onto the rotating plate to form a ribbon bed which is carried to the plough and discharged to rejects. As a slot passes through the stream, a cut is taken.

Key

- 1 feed
- 2 reject
- 3 divided sample

A hollow shaft with a rotating conical hopper and chute which distributes the coal to one or more stationary cutters within a housing as shown. Each cutter is designed to take cuts from the coal stream and the rejects are discharged through the hollow shaft.

Figure 2 — Examples of dividers (continued)

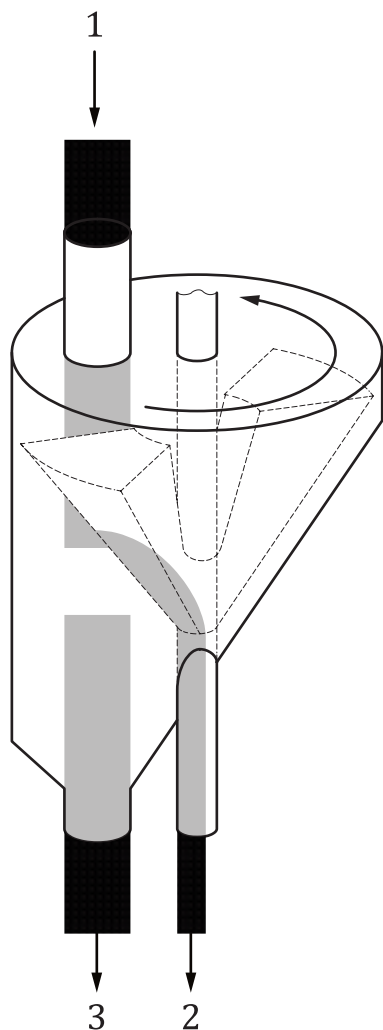

h) Rotating cutter type

Key

- 1 feed
- 2 divided sample
- 3 reject

One or more rotating cutters take cuts from the coal stream as it is fed into the housing through a feed chute as shown. Coal not collected by the rotating cutters is directed to reject at the bottom of the housing.

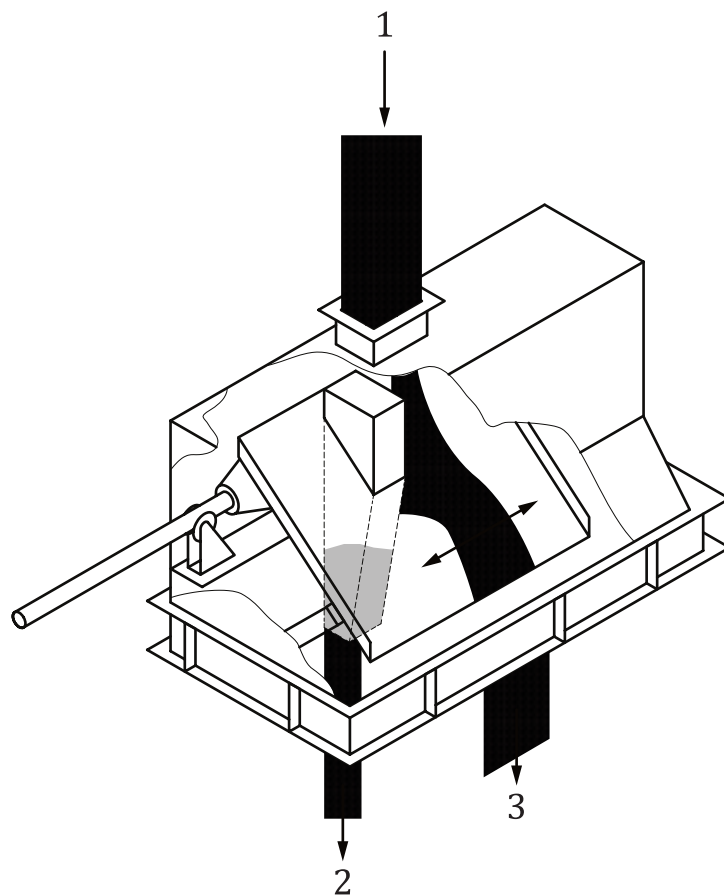

i) Cutter-chute type

Key

- 1 feed
- 2 divided sample
- 3 reject

The cutter-chute traverses the full coal stream and diverts a portion from the stream. When the coal stream is not being cut by the chute, it is deflected by the angle plate to reject.

Figure 2 — Examples of dividers (continued)

6.2 Mechanical methods

6.2.1 General

Mechanical sample division may be carried out on an individual increment or a sample which has been crushed, if necessary, to an appropriate nominal top size. Division shall be either by fixed-mass division or by fixed-ratio division subject to the conditions set out in [6.2.3](#).

NOTE The procedures described for fixed-ratio division are the simplest to implement. However, other procedures can be used, provided that the mass of the divided sample is proportional to the mass of the feed, e.g. the number of cuts could be kept constant by making the feed rate of each division proportional to the mass of coal to be divided.

6.2.2 Mass of cut

The cuts shall be of uniform mass throughout the division of an increment. In order to achieve this, the flow of coal to the divider shall be uniform and the cutting aperture shall be constant. The method of feeding the divider shall be designed to minimize any segregation caused by the divider.

The cutting aperture shall be at least three times the nominal top size of the coal to be divided.

6.2.3 Interval between cuts

In order to minimize bias, the first cut for each mass to be divided shall be made at random within the first cutting interval. For secondary and tertiary dividers, the cycle time shall not be evenly divisible into the cycle time of the cutter which precedes it.

For fixed-mass division, the interval between taking cuts shall be varied proportionally to the mass of coal to be divided so that divided samples having almost uniform mass are obtained.

For fixed-ratio division, the interval between taking cuts shall be constant, irrespective of the variations of masses of coal to be divided, so that the divided-sample masses are proportional to the mass of the feed.

6.2.4 Division of individual increments

6.2.4.1 Number of cuts

The number of cuts for dividing an increment shall be determined as follows.

- a) For fixed-mass division, the minimum number of cuts for dividing primary increments shall be four. An equal number of cuts shall be taken from each primary increment in the sub-lot.
- b) For fixed-ratio division, the minimum number of cuts for dividing a primary increment of mean mass shall be four.
- c) For subsequent division of individual divided primary increments, a minimum of one cut shall be taken from each cut from the preceding division.

An example of a procedure for division of individual increments and subsequent sample division is shown in [Figure 3 a](#)).

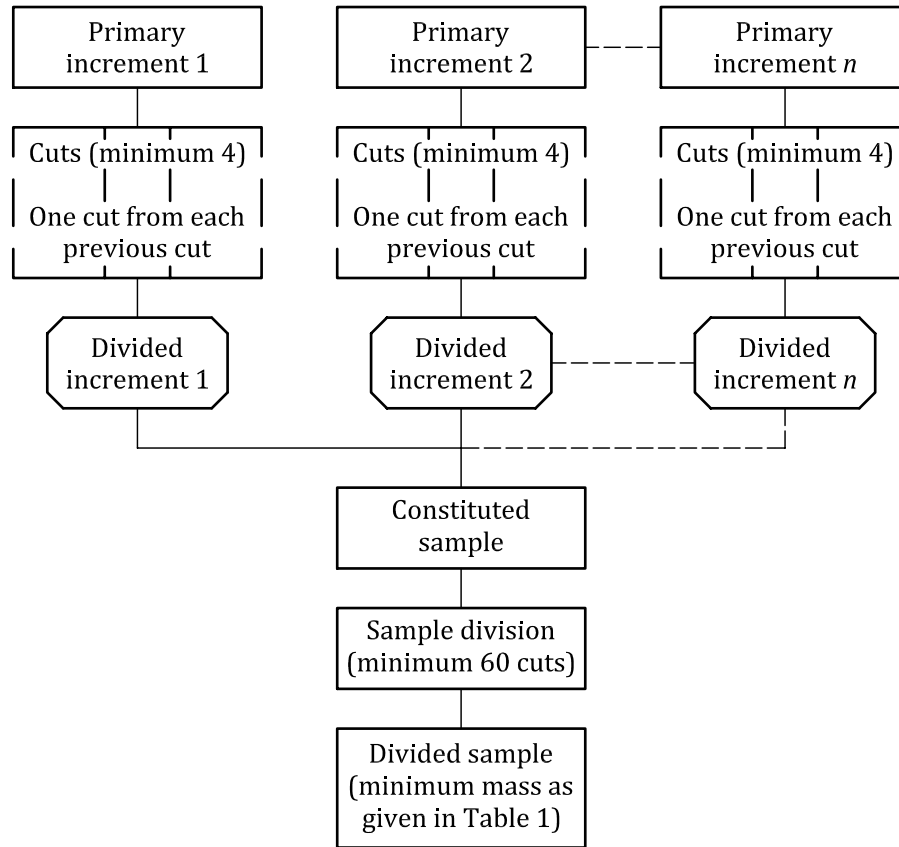

a) Example of division of individual increments (minimum number of cuts)

Figure 3 — Examples of procedures for division of increments and samples

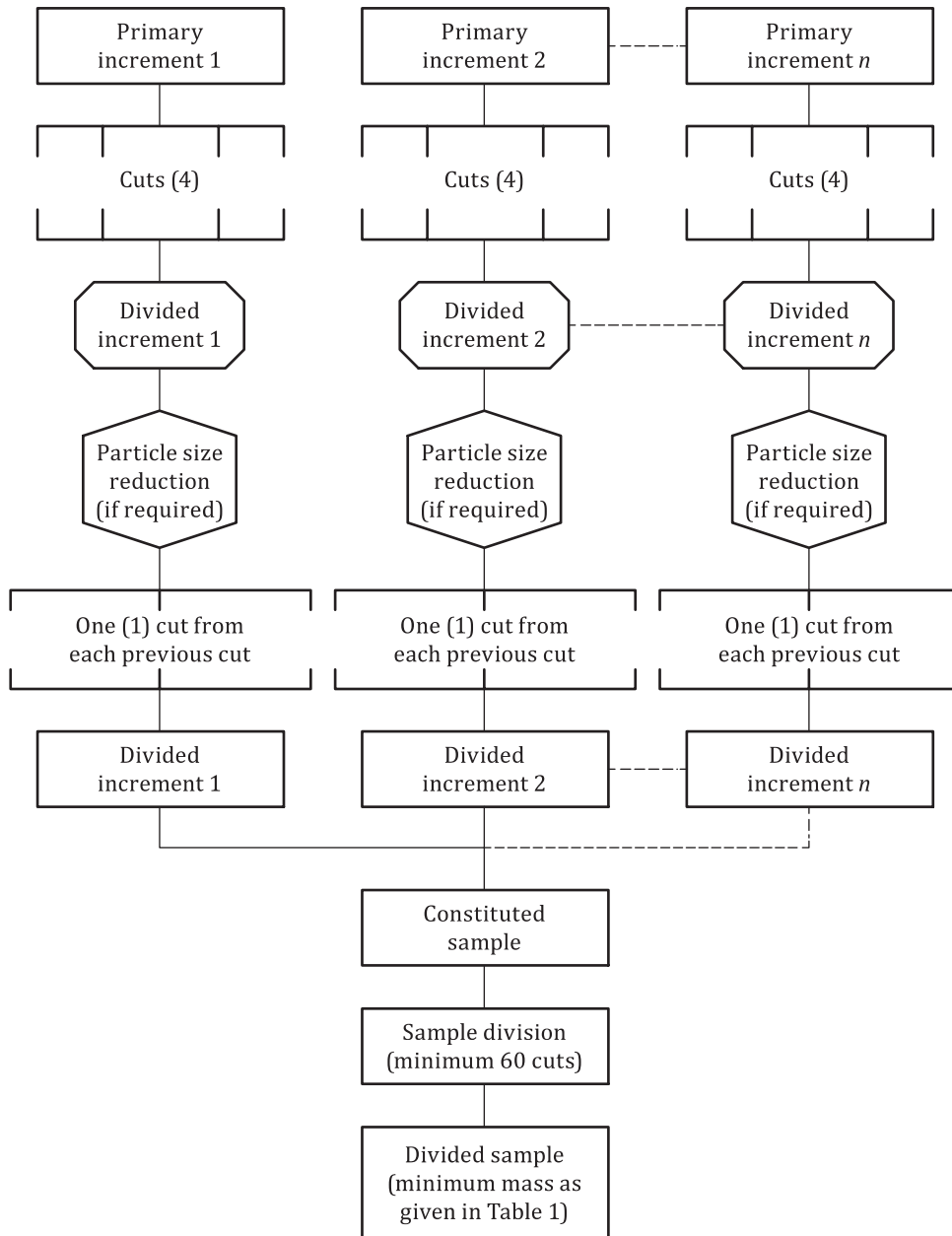

b) Example of two-stage division of individual increments

Figure 3 — Examples of procedures for division of increments and samples (continued)

6.2.4.2 Minimum mass of divided increment

The minimum mass of a divided increment shall be such that the combined masses of all the divided increments in the sub-lot shall, at each stage, be greater than the mass given in [Table 1](#) corresponding to the purpose for which the sample has been taken and the nominal top size. If the increment masses are too low to satisfy this requirement, the divided increment shall be crushed prior to further division (e.g. as shown in [Figure 3 b](#)).

6.2.5 Division of samples

6.2.5.1 Number of cuts

The sample constituted from all increments, or divided increments, shall be divided by taking a minimum of 60 cuts.

NOTE If, during preparation, the sample is thoroughly mixed and it can be established that the required precision can be achieved, the number can be reduced to 20.

If the mass is too low, an alternative manual method of division should be used.

6.2.5.2 Minimum mass of divided samples

For most parameters, particularly size analysis and those that are particle-size related, the precision of the result is limited by the ability of the sample to represent all the particle sizes in the mass of coal being sampled.

The minimum mass of divided samples is dependent on the nominal top size of the coal, the precision required for the parameter concerned and the relationship of that parameter to particle size. The attainment of the required minimum mass after division will not, in itself, guarantee the required precision, because division precision is also dependent on the number of cuts taken during division (see [6.2.4.1](#) and [6.2.5.1](#)).

Values for the minimum mass of divided samples for general analysis to reduce the variance due to the particulate nature of the coal to 0,01, corresponding to a precision of 0,2 % with regard to ash, are given in [Table 1](#) (see CSIRO report^[1]). [Table 1](#) gives the corresponding minimum masses of divided samples for total moisture analysis, which are approximately 20 % of the minimum masses for general analysis, subject to an absolute minimum of 0,65 kg. Values for the minimum mass of divided samples for size analysis are given in [Table 1](#) for division precisions of 1 % and 2 % respectively. These masses have been calculated on the basis of the precision of the determination of oversize, i.e. the coal above the normal top size. The precision for other size fractions will normally be better than this. Note that, in each case, the overall division precision is determined by the sum of the division variances for each sample-division stage.

The minimum mass of divided samples, m_S , for other desired levels of precision may be calculated from [Formula \(2\)](#):

$$m_S = m_{S,0} \left(\frac{P_0}{P_R} \right)^2 \quad (2)$$

where

$m_{S,0}$ is the minimum mass of sample after division specified in [Table 1](#) for a given nominal top size;

P_0 is the precision for a given division stage specified in [Table 1](#);

P_R is the required precision for a given division stage.

When a coal is regularly sampled under the same circumstances, the precision obtained for all the required quality parameters shall be checked (see ISO 13909-7) and the masses may be adjusted accordingly. However, the masses shall not be reduced below the minimum requirements laid down in the relevant analysis standards.

When preparing coal to produce samples for multiple use, account shall also be taken of the masses and size distribution of the test samples required for each test.

Table 1 — Minimum mass of sample after division

Nominal top size of coal mm	General-analysis and common samples kg	Total-moisture analysis samples kg	Size-analysis	
			1 % precision kg	2 % precision kg
300	15 000	3 000	54 000	13 500
200	5 400	1 100	16 000	4 000
150	2 600	500	6 750	1 700
125	1 700	350	4 000	1 000
90	750	125	1 500	400
75	470	95	850	210
63	300	60	500	125
50	170	35	250	65
45	125	25	200	50
38	85	17	110	30
31,5	55	10	65	15
22,4	32	7	25	6
16	20	4	8	2
11,2	13	2,5	3	0,7
10	10	2,0	2	0,5
8	6	1,5	1	0,25
5,6	3	1,2	0,5	0,25
4	1,5	1,0	0,25	0,25
2,8	0,65	0,65	0,25	0,25
2,0	0,25	0,65	0,25	0,25
1	0,1	0,65	0,25	0,25
< 0,5	0,06	0,65	0,25	0,25

NOTE 1 The masses for the general-analysis samples and common samples have been determined to reduce the variance due to the particulate nature of coal to 0,01, corresponding to a precision of 0,2 % ash.

NOTE 2 These values are generally suitable for off-line division but, for nominal top sizes of 16 mm and below, the masses may not be sufficient to maintain the integrity of the sample when performing on-line division.

6.3 Manual methods

6.3.1 Riffle method

A riffle (see [Figure 4](#)) is a sample divider that will, in a single pass of a sample, divide it into halves, one of which is retained and the other normally rejected. The device is normally portable and, for sample division, is usually fed manually, the coal being evenly distributed along its length. Adjacent slots feed opposite receivers.

The slot width shall be at least three times the nominal top size of the coal. Each half of the riffle shall have the same number of slots, which shall be at least eight and preferably more. All the surfaces on which the coal might rest shall have a slope of at least 60° to the horizontal.

The coal shall be allowed to fall steadily into the riffle, ensuring that it is evenly distributed over all the slots. The coal shall be allowed to fall freely, i.e. not towards one side of the riffle, and the rate of feed shall be controlled such that the slots are never choked. Closed riffles are preferred.

Care shall be taken to minimize loss of dust and moisture. To this end, the receiver shall fit closely against the body of the riffle, and, for dry coals and moisture samples, closed-type riffles shall be used.

When a stage of sample division requires two or more steps or passes, the sample retained at each step shall be taken alternately from each side of the riffle.

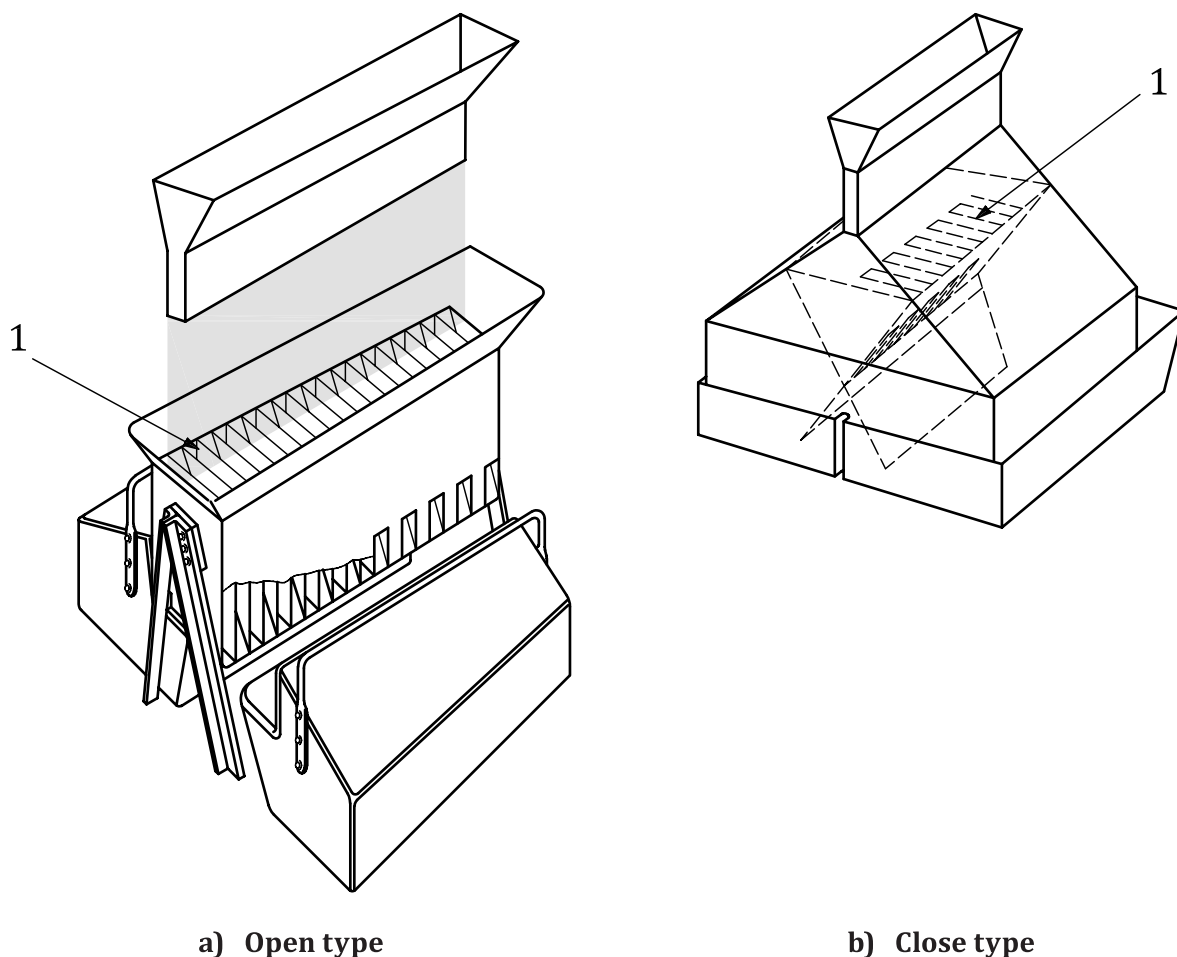

Key

1 even number of slots

Figure 4 — Examples of riffles

6.3.2 Flattened-heap method

The procedure, which is illustrated in [Figure 5](#), is as follows.

The sample is mixed thoroughly and spread to form a rectangle of uniform thickness on a mixing plate which is a smooth, non-absorbent and non-contaminating surface. The maximum thickness shall be three times the nominal top size of the coal. Avoid moisture loss from wet coals, which can result from over-mixing.

If the mass of the coal is greater than can be formed into a heap of 2 m × 2,5 m, two or more heaps of equal mass shall be formed and separate samples shall be taken from each heap.

A matrix is marked on the spread sample to give a minimum of 4 × 5 equal parts. An increment is taken, at random, from each of the parts by inserting a scoop with a bump plate (see the last paragraph of [6.3.2](#)) to the bottom of the matrix layer. The increments are combined into a divided sample. It is essential that these operations be performed quickly to prevent moisture loss.

The increments shall be of uniform mass. The minimum mass required for each nominal top size is the mass of the divided sample (see [Table 1](#)) divided by the number of parts of the flattened heap. This mass is determined by using a scoop of appropriate dimensions.

The scoop shall be flat bottomed and the width of the entry shall be at least three times the nominal top size of the coal. The side walls shall be higher than the height of the heap and the depth shall be sufficient to allow the required mass of increment to be taken.

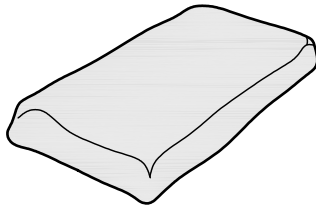

a) Spread the crushed sample into a rectangle with a maximum thickness of three times the nominal top size.

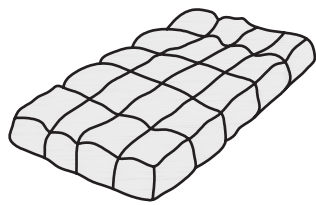

b) Arrange into 20 equal parts, e.g. into five equal parts lengthwise and four equal parts breadthwise.

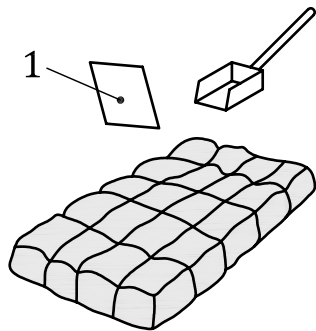

c) Take a scoopful of sample at random from each of the 20 parts by inserting the scoop to the bottom of the sample layer [see [Figure 5 d](#)] below]. Combine the 20 scoopfuls to form the divided sample.

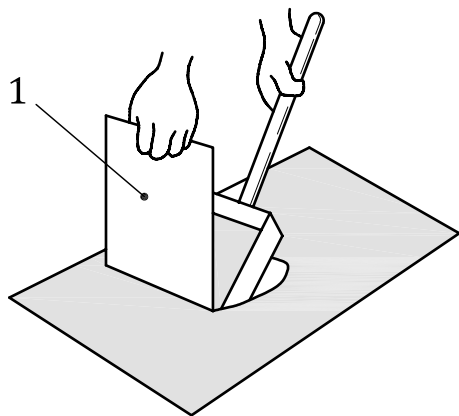

d) Detail of taking an increment by using the bump plate (1) shown in [Figure 5 c](#)).

Key

1 bump plate

Figure 5 — Flattened-heap method

Take the scoop sample with the aid of a bump plate, which is inserted vertically through the flattened heap until it is in contact with the bottom of the sample layer. The scoop is then inserted to the bottom of the spread coal and moved horizontally until its open end comes into contact with the vertical bump plate. The scoop and bump plate are lifted together to ensure that all particles are collected off the top of the mixing plate and that none fall off during lifting.

6.3.3 Strip-mixing and splitting method

The procedure, which is illustrated in [Figure 6](#), is as follows.

The coal sample is formed on a mixing plate, which is a smooth, non-absorbent, non-contaminating surface, into a strip at least 10 times as long as it is wide by distributing the coal along the length of the strip as evenly as possible, working randomly from end to end and from both sides of the strip. End plates are used to ensure that size segregation only occurs laterally.

Increments shall be taken as a complete section across the strip. The width of each cross-section shall be not less than three times the nominal top size of the coal.

NOTE 1 Special apparatus for the cutting out of increments may be constructed if desired.

Normally 20 increments are required. Fewer increments may be taken, subject to a minimum of 10, where the same quality coal is regularly prepared under the same conditions and it has first been established that the required precision can be obtained (see ISO 13909-7).

NOTE 2 Because of the efficient longitudinal mixing achieved in the formation of a strip, the same precision as that obtainable with the flattened-heap method may be achieved with fewer increments.

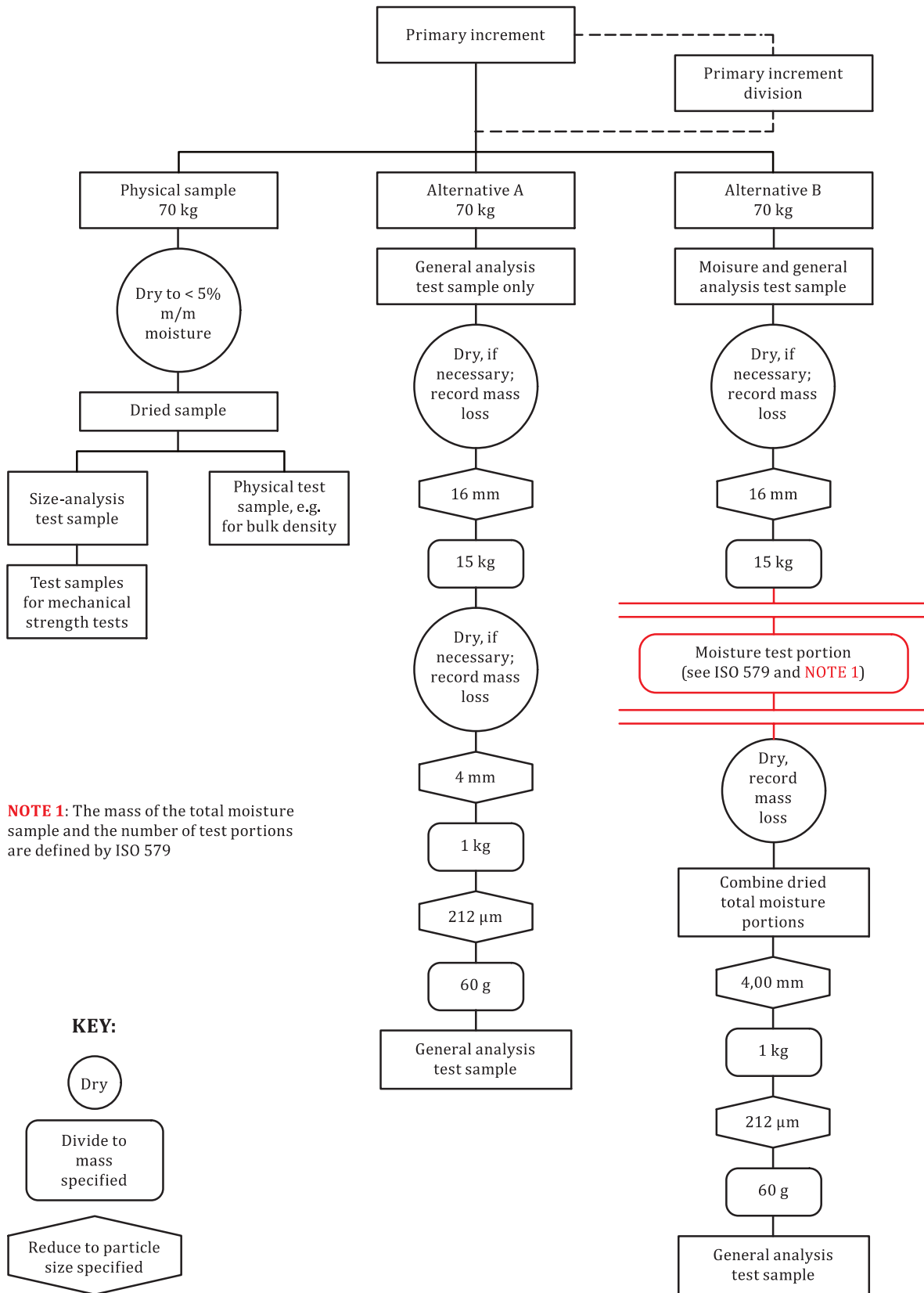

NOTE 1: The mass of the total moisture sample and the number of test portions are defined by ISO 579

KEY:

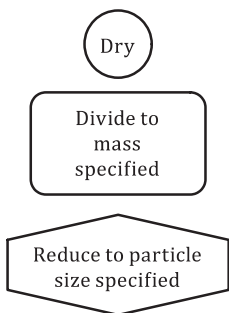

Key

- 1 increment
- 2 sampling frame

3 end plates ("book ends")

Figure 6 — Strip-mixing and splitting method

7 Reduction

7.1 General

Mechanical equipment shall be used to reduce the particle size, but manual crushing is permitted for the breakage of large material to meet the maximum feed size acceptable to the first-stage mill.

The test sample shall be reduced to the particle size specified in the relevant test method.

The mill settings should be checked regularly by sieving and determining the nominal top size produced by each mill.

7.2 Reduction mills

The particle size produced depends on the speed of the mill and its design. Mills shall be designed such that the required particle size of the reduced sample can be achieved without using extreme settings. Loss of sample or retention of material from previous samples, which might contaminate succeeding samples, shall be minimized. Heating of the sample and airstream effects shall be minimized, particularly where the sample is to be used for total moisture determination, calorific value determination, and coking tests.

There shall be no contact between the metal surfaces in order to avoid localized heating of the sample. Totally closed, high-speed (>20 Hz) ball mills shall not be used. The particle size of the output is influenced by the hardness of the coal, but the effect will depend on the speed range.

For certain tests, specified size gradings are required and the type of mill shall be chosen to ensure that the required size is obtained.

8 Mixing

Mixing is not possible where samples or increments are flowing through any form of preparation system and is therefore restricted to off-line preparation.

In theory, thorough mixing of a sample prior to its division reduces errors due to sample preparation. In practice, this is not easy to achieve and some methods of hand mixing, e.g. forming and reforming into a conical pile, can have the opposite effect leading to increased segregation. Mixing may also result in loss of moisture.

One method that can be used is to pour the sample through a riffle ([6.3.1](#)) or a container-type sample divider [see [Figure 2 c](#)] three times, reuniting the parts after each pass. If mechanical sample dividers are used in the course of preparation, an additional mixing step is not normally necessary to meet the required precision.

NOTE Mechanical mixing may be useful at the final stage of preparation of test samples.

9 Air-drying

The sample is spread in a thin layer and allowed to attain equilibrium with the atmosphere at ambient temperatures.

The coal layer shall not exceed a thickness of 1,5 times the nominal top size of the coal or a loading of 1 g/cm², whichever is the greater.

The recommended times to attain equilibrium at different ambient temperatures up to 40 °C are given in [Table 2](#). The times recommended in [Table 2](#) will normally be sufficient, but if necessary a longer drying time may be used, provided that any increase is kept to a minimum, especially for coals susceptible to oxidation.

Table 2 — Recommended drying times for air-drying

Drying temperature °C	Drying time h
20	Preferably not to exceed 24
30	Preferably not to exceed 6
40	Preferably not to exceed 4

Drying temperatures above 40 °C shall not be used on samples likely to be susceptible to oxidation or if the sample is to be used for any of the following tests:

- a) calorific value;
- b) caking properties;
- c) swelling properties;
- d) air-drying as part of a determination of total moisture.

For drying temperatures above normal ambient, a cabinet or oven with appropriate air-change facilities shall be used. If drying has been carried out at such temperatures, the sample shall be cooled until moisture equilibrium at normal ambient temperature is achieved before reweighing. The cooling period required will depend on the drying temperature. For example, 3 h is normally sufficient if the sample has been dried at 40 °C.

10 Preparation of samples for specific tests

10.1 Types of test samples

The following types of test sample may be prepared:

- a) samples for determination of total moisture only;
- b) samples for general analysis only (i.e. not to be used for determining total moisture);
- c) common samples for both total moisture determination and for general analysis;
- d) samples for size analysis;
- e) samples for other tests, e.g. determination of Hardgrove Grindability Index.

The methods of preparation will depend on the purpose for which the original sample was collected.

10.2 Preparation of samples for determination of total moisture only

10.2.1 General

The test sample for the determination of total moisture content shall be prepared to meet the requirements of ISO 589. If air-drying is performed at any stage of preparation, the percentage loss in mass shall be recorded and included in the calculation of total moisture as specified in ISO 589:1981¹⁾, 8.2.

1) This is a withdrawn International Standard and has been replaced by ISO 589:2008.

A major problem with the preparation of test samples for the determination of moisture content is the risk of bias due to inadvertent loss of moisture. The amount of this loss is dependent on such factors as the effectiveness of the sealing of the sample containers, the level of moisture content of the sample, the ambient conditions, the type of coal and the reduction and division equipment and procedures used.

A sample may be prepared as a test sample with or without preliminary air-drying, but the preferred procedure is to divide the uncrushed sample to a mass not less than that given in [Table 1](#) and air-dry it. The sample is then crushed and divided to the required test sample state.

Preliminary air-drying may be necessary in order to minimize moisture loss in any subsequent reduction/division stages. Reduction/division shall only be carried out prior to air-drying if it does not result in moisture bias.

If the coal is so wet that water separates from the coal in the sample container, the whole of the sample and the container shall be air-dried and the loss in mass recorded and included in the calculation of total moisture content as specified in ISO 589.

If the mass of the uncrushed sample is so large that air-drying is impracticable, the samples shall be crushed and divided before air-drying. Crushing shall be kept to the minimum necessary to allow division to a manageable mass. The absence of bias due to these procedures shall be checked using the procedures given in ISO 13909-8.

If the particle size of the sample is so large that the mass given in [Table 1](#) makes its air-drying impracticable, the sample shall be crushed and divided before air-drying. Crushing shall be kept to the minimum necessary to allow division to a manageable mass.

The preparation process shall be tested for bias using the procedures given in ISO 13909-8, by comparison with the method of drying samples without reduction.

An example of a scheme for the preparation of a sample for a two-stage moisture test is given in [Figure 7](#).

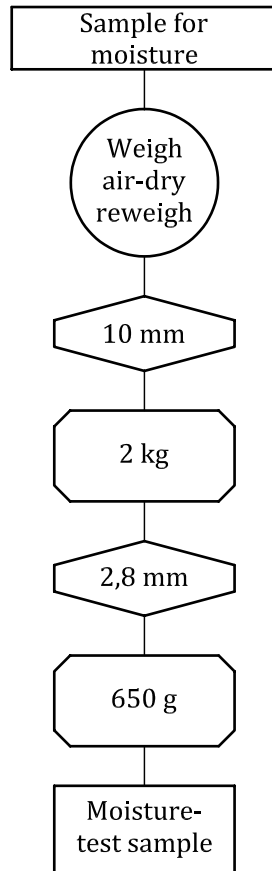

Note

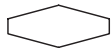

Reduce to particle size specified.



Divide to mass specified.

Figure 7 — Example of a two-stage moisture-test sample preparation

10.2.2 Storage

Precautions shall be taken to minimize changes of moisture content during preparation due to the use of unsuitable containers and to evaporation during handling. All samples for moisture determination shall be kept in moisture-tight containers in a cool place, under cover, before and during preparation as well as during any interval between steps of sample preparation.

If excessive standing time causes bias, increase the number of sub-lots to overcome these problems (see ISO 13909-2 or ISO 13909-3).

Weigh the samples stored for moisture determination before storage to allow determination of any moisture change that takes place during storage.

10.2.3 Sample reduction

Care shall be taken to minimize changes in moisture content during reduction, by using equipment in which there is no appreciable heating and by reducing to a minimum the flow of air through the mill. If such changes cannot be minimized, then the uncrushed sample shall be air-dried prior to crushing according to ISO 589.

10.2.4 Sample division

When carrying out sample division prior to air-drying of a sample or increment, care shall be taken to minimize changes of moisture content. To this end, all divisions shall be carried out as quickly as possible and mechanically operated dividers with limited ingress of air shall be used.

NOTE For coals which are too moist to flow through a sample divider and for which it is also impossible to air-dry the entire sample, it may be necessary to divide the sample by collecting increments from a flattened-heap (6.3.2) or by strip-mixing and splitting (6.3.3). This divided sample is then air-dried.

10.3 Preparation of samples for general analysis only

10.3.1 General

The objective of general-analysis sample preparation is to prepare a test sample which will pass a sieve with 212 μm nominal size openings conforming to the requirements of ISO 3310-1. The mass of the test sample depends on the analysis required, but is between 60 g and 300 g.

Sample preparation is normally carried out in two or three stages, each consisting of drying (if necessary), size reduction, mixing (if necessary) and division.

10.3.2 Air-drying

Air-drying in connection with preparation for general analysis is only carried out to ensure that the coals can pass freely through the equipment. Loss of moisture during the preparation is of no relevance and consequently it is not necessary to measure the loss of mass.

Air-drying may be carried out at any stage, provided that it does not affect the quality of the sample. For example, if the sample is to be used for the determination of calorific value, coking or swelling properties, the maximum drying temperature shall be 40 °C. If drying can be avoided during the first stage of preparation, the procedure can be simplified.

10.3.3 Reduction and division

Reduction and/or division of increments takes place in accordance with the requirements of [Clause 6](#) and [Clause 7](#) down to a nominal top size of 2,8 mm prior to their combination to form samples.

NOTE 1 If the coal is wet, it may not be possible to crush it so finely because of blocking of chutes, dividers, mills, feeders, etc.

If possible, reduce the coal to a nominal top size of 2,8 mm in the first stage in order to minimize the mass of sample retained for the next stage as well as to minimize errors due to sample division.

NOTE 2 It may be necessary to use a stamp or a maul to break oversize particles to the maximum feed size of the crushing device.

If the original nominal top size of the coal is too large, or if the coal is too wet, an intermediate stage may be required. In this case, the retained sample from the first stage shall be passed through a second mill to reduce the nominal top size to 2,8 mm.

The sample shall be divided by means of a suitable sample divider to the mass corresponding to the nominal top size in accordance with [Table 1](#).

The sample is reduced and divided in one or two further stages to the nominal top size and mass required for the test sample and it is finally thoroughly mixed.

Mechanical or manual division may be used, the former being preferred. For mechanical division, a suitable divider to give 60 g to 300 g of 212 μm coal is required. For manual division, a riffle may be used, or the sample spread out and 60 g to 300 g taken by hand in not less than 20 increments from various parts of the flattened heap.

An example of a scheme for preparation of a general-analysis test sample is given in [Figure 8](#).

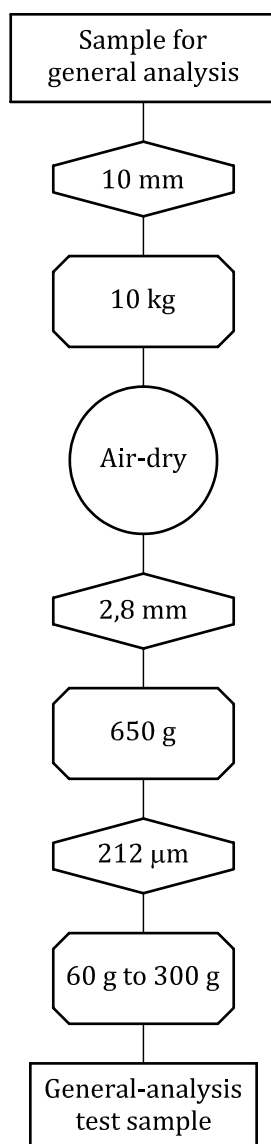

Note

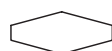

Reduce to particle size specified.



Divide to mass specified.

Figure 8 — Example of preparation of a general-analysis test sample

10.4 Common samples

10.4.1 General

In some circumstances, it is more convenient to take a common sample for both moisture determination and general analysis.

It is preferable to extract the moisture sample by using a mechanically operated divider in accordance with [10.4.2](#).

If the common sample is visibly wet and it is impossible to air-dry the entire sample, use a manual method in accordance with [10.4.3](#).

Examples of schemes for the preparation of separate test samples for moisture and for general analysis from a common sample are given in [Figure 9](#). Sometimes a single test sample may be prepared for both moisture determination and general analysis.

As a result of the extraction, the common sample has been divided into two parts, one for preparation of the moisture test sample and one for preparation of the general-analysis test sample. Each part shall fulfil the requirements for minimum mass specified in [Table 1](#) and further treatment of the parts shall be in accordance with [10.2](#) and [10.3](#) respectively.

10.4.2 Extraction of moisture sample by mechanical division

The extraction of the moisture sample may be carried out at any convenient stage of the preparation procedure consistent with the requirements of [10.2.3](#). Prior to extraction, the sample shall be treated in accordance with [10.2](#) in order to avoid any inadvertent loss of moisture. If air-drying is part of the preparation prior to extraction, the loss of mass during the drying shall be measured, recorded and included in the calculation of total moisture content as specified in ISO 589.

10.4.3 Extraction of moisture sample by manual method

Extract a moisture sample by collecting increments by the flattened-heap method ([6.3.2](#)) or by the strip mixing and splitting method ([6.3.3](#)).

Avoid further treatment of the moisture sample before air-drying to reduce the risk of bias in the moisture determination. Further treatment after air-drying shall be carried out as described in [10.2](#). The residual coal after extraction constitutes the sample from which the general-analysis test sample is prepared, and is treated as described in [10.3](#).

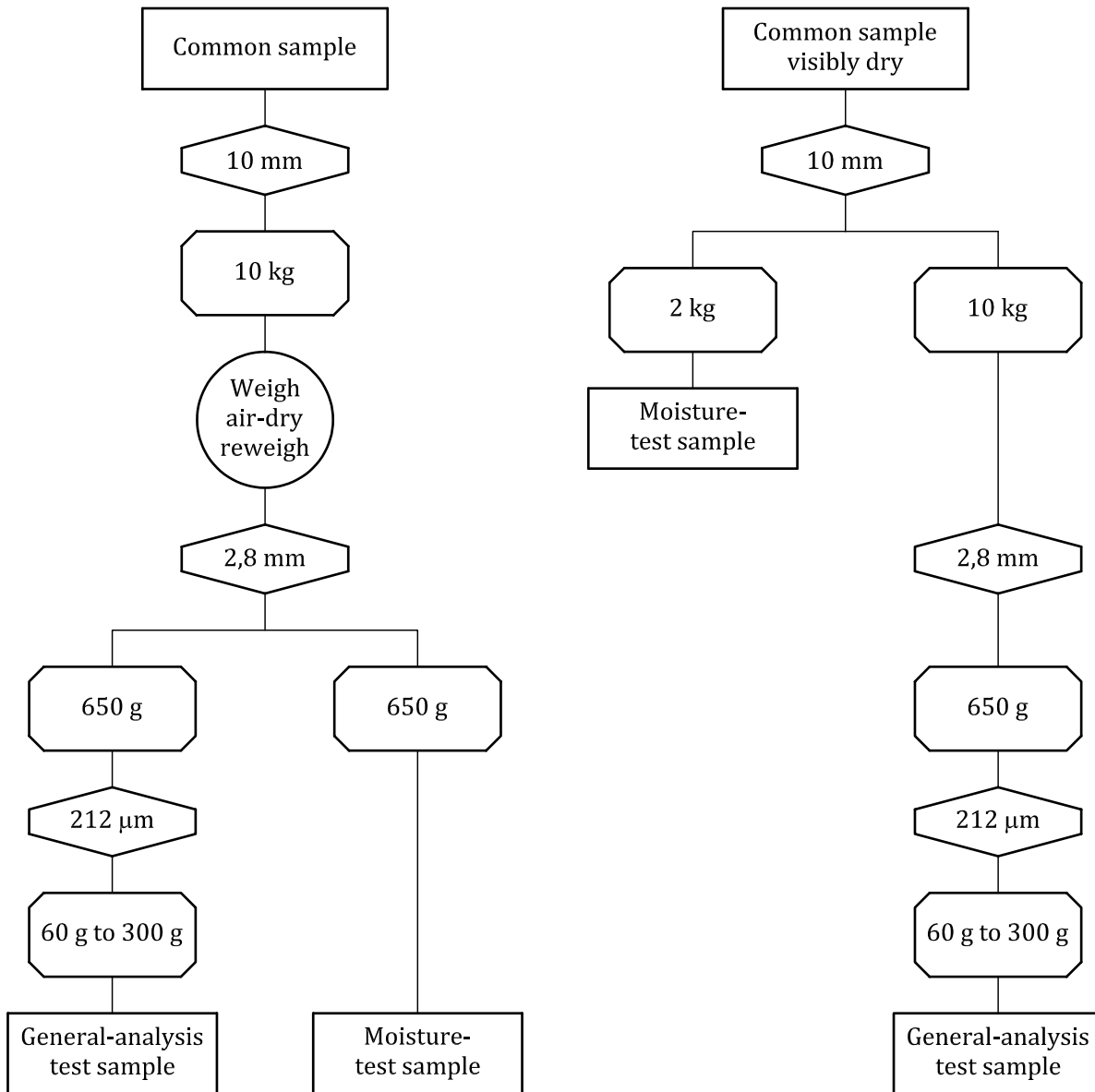

Note

-  Reduce to particle size specified.
-  Divide to mass specified.

Figure 9 — Examples of preparation of test samples from a common sample for moisture determination and general analysis

10.5 Preparation of size-analysis sample

If the mass of the size-analysis sample is more than twice that given in [Table 1](#) for the appropriate nominal top size, it may be divided to a mass not less than that given in [Table 1](#), provided that the requirements for division (see [Clause 6](#)) are satisfied. Also, some samples will need to be air-dried as described in [Clause 10](#) before sample division and size analysis is undertaken. During division, precautions shall be taken to avoid breakage. An example of a scheme for the preparation of test samples for size analysis is given in [Figure 10](#).

If the nominal top size of the coal is greater than one-third of the cutting aperture of the sample divider, oversize material may be removed by sieving out and the whole of this oversize portion subjected to

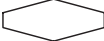
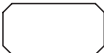
size analysis. The undersize coal should be divided to a mass not less than that given in [Table 1](#) for the appropriate nominal top size. The divided sample should then be subjected to size analysis and the results combined with those from the oversized coal, weighted according to their relative proportions in the original sample.

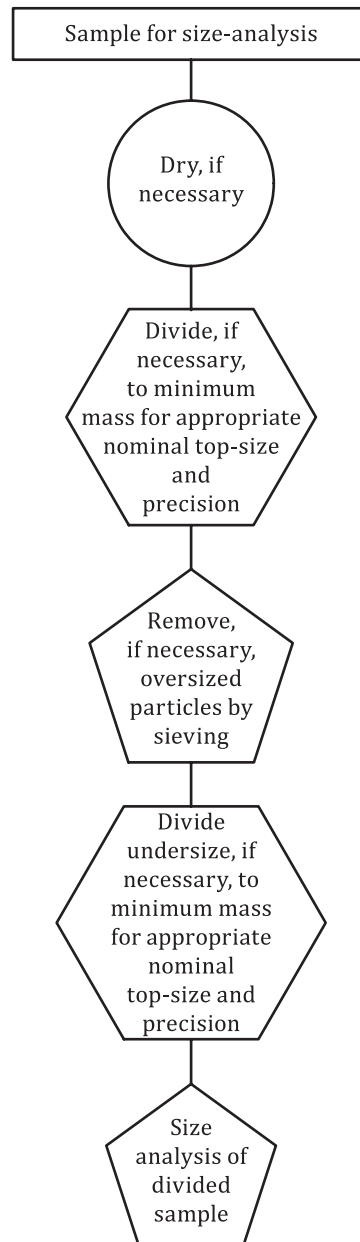

Note



Figure 10 — Example of preparation of samples for size analysis and/or other tests

10.6 Preparation of samples for other tests

Preparation shall be as described in [10.3](#) or [10.4](#), except that the nominal top size and mass of the test sample shall be as required in the relevant test method. An example of a scheme for the preparation of such test samples is given in [Figure 10](#).

11 Reserve sample

If a reserve sample is taken for examination in the event of a dispute or in case the results of the first tests are lost or invalid, it shall be collected at the same time and prepared in the same way as the ordinary sample.

It is recommended that the reserve sample be divided as little as possible and no further than to the maximum mass which it is still practicable to store. It should not be reduced further than to the nominal top size consistent with the mass given in [Table 1](#).

12 Design of equipment for preparation

12.1 Dividers

Division devices shall

- a) have sufficient capacity to retain completely or to pass the entire sample without loss or spillage,
- b) not introduce bias, for example by selective collection (or rejection) by particle size or by loss of moisture,

NOTE In order to avoid moisture loss, in some circumstances totally enclosed dividers may be necessary.

- c) use a method of feeding which minimizes the segregation of the coal,
- d) provide a controlled uniform flow to the equipment at each stage of division, and
- e) in the case of on-line mechanical dividers, have cutting frequencies which are not in phase with preceding equipment.

It is desirable that the equipment be able to provide a random start within the first sampling interval for the first cut on each mass of coal to be divided in order to minimize bias. It is essential that the divider be set in motion before feeding of coal commences.

12.2 Design of cutters for falling-stream dividers

12.2.1 General

A cutter intended for dividing a falling stream of coal shall be designed to meet the following requirements in addition to those specified in [12.1](#):

- a) the cutter shall take a complete cross-section of the stream;
- b) the leading and trailing cutting edges shall describe the same plane or the same cylindrical surface, as appropriate, and this plane or surface shall be normal to the mean trajectory of the stream;
- c) the cutter shall travel through the coal stream at a uniform velocity, i.e. the velocity shall not deviate by more than 5 % from the preselected reference velocity at any point (see [12.2.2](#));
- d) the design of the cutter aperture shall be such that all parts of the stream are exposed to the aperture for the same length of time;
- e) the effective capacity of the sampling cutter shall be such that, at the expected maximum flow rate of the coal stream, it will retain or pass the whole of the increment without loss or spillage and without any part of the cutter becoming blocked or restricted by material already collected;
- f) the width of the cutter aperture shall be at least three times the nominal top size of the coal. If the cutter aperture is tapered, as is the case with some swing-arm type samplers, the minimum width requirement shall apply to the narrow end.

12.2.2 Cutter velocity

The width of the cutter aperture and the cutter velocity are important parameters to be considered when designing a sample cutter. Taken jointly with the velocity of the coal stream, these parameters will determine the effective width of the cutter aperture, i.e. the width of that part of the aperture into which the stream of coal can flow unimpeded.

For falling-stream cutters, experimental work on ores^[2] has shown that for sampling heterogeneous material streams of low belt loading, where particle size distribution is very narrow, bias may be introduced when the cutter speed exceeds 0,6 m/s or the cutter aperture is less than three times the nominal top size of the material.

The ratio of the effective cutter width to the nominal top size of the coal will decisively influence the capability of the cutter to take unbiased increments, since the greater this ratio is, the less will the tendency be to selectively reject the larger particles.

On the basis of this evidence, cutters that have a cutter aperture width, b , equal to three times the nominal top size of the coal shall not exceed a cutter speed of 0,6 m/s.

For cutters where the aperture is in excess of three times the nominal top size, the maximum cutter speed, v_C , can be increased in accordance with [Formula \(3\)](#), subject to a maximum speed of 1,5 m/s:

$$v_C = 0,3 \left(1 + \frac{b}{3d} \right) \quad (3)$$

where

b is the cutter aperture width, in millimetres;

d is the nominal top size of the coal, in millimetres.

Irrespective of cutter speed and aperture, the cutter shall be shown to be capable of collecting unbiased increments.

12.3 Preparation systems

12.3.1 General

Ideally, the mechanical system shall be designed at the same time as the coal-handling plant. In that event, the main plant can be designed to accommodate the mechanical sampling system and the best practicable conditions for its operation can be ensured. However, even if the system is added to an existing plant, it is essential that engineering expediency is not allowed to cause any condition which would make the system biased.

The design of the system for sampling and sample preparation shall be related to the types of coal to be handled, the quality characteristics to be determined and the maximum number, mass and frequency of increments anticipated as discussed in [Clause 6](#).

12.3.2 Design criteria

The system shall be designed and engineered in such a way that

- a) it is capable of preparing samples in an unbiased manner, and can maintain this capability under all conditions of sampling that are stipulated in the relevant specifications and without necessitating interruption of preparation for cleaning or maintenance,
- b) due consideration is given to the safety of the operation from the initial stages of design and construction and all safety codes applicable at the site where the equipment is to be installed are respected,

- c) it is sufficiently robust to withstand adverse operating conditions,
- d) the system as a whole, including dividers, chutes, hoppers, feeders, crushers and other equipment, can operate in a manner that facilitates material flow and minimizes the need for cleaning to prevent and clear blockages,
- e) any contamination of the sample, e.g. by material retained from an earlier sample, is avoided,
- f) degradation of the constituent particles is minimized if a sample is taken for particle-size determination, and
- g) any change in moisture content, chemical or physical properties, or loss of fine coal (e.g. caused by excessive air flow through the equipment) is minimized.

12.3.3 Abnormal operation

A mechanical system shall be designed to ensure a sufficient degree of operating flexibility such that even under abnormal conditions, for instance when part or parts of the system are disabled due to breakdown or because they have become choked, the remainder of the system (assisted if necessary by suitable off-line preparation) is still capable of performing satisfactorily.

12.4 Provision for checking for precision

The sampling system shall be capable of either processing the increments to constitute duplicate samples by combining the increments alternately, or processing the increments to constitute replicate samples by combining the increments in rotation.

The latter capability should preferably be available when sampling coals of unknown variability.

Procedures for checking precision by means of duplicate and replicate sampling are described in ISO 13909-7.

12.5 Provision for testing for bias

To allow bias tests to be carried out in accordance with ISO 13909-8, provision shall be made for reference samples to be taken.

Adequate access shall be provided to allow correct sampling from the coal stream within the system to facilitate dynamic testing of subsystems and components (see ISO 13909-8).

Bibliography

- [1] HOLMES R.J. Assessment of Minimum Sample Mass for Coal, Mineral Engineering Communication, MIE/C23, CSIRO Division of Mineral Engineering, May 1987,
- [2] GY P.M. Sampling of Heterogeneous and Dynamic Material Systems, Elsevier Scientific Publishing, Amsterdam. 1992

