

INTERNATIONAL
STANDARD

ISO
13860

Second edition
2016-03-01

**Machinery for forestry — Forwarders
— Terms, definitions and commercial
specifications**

*Matériel forestier — Débardeuses — Termes, définitions et
spécifications commerciales*



Reference number
ISO 13860:2016(E)

© ISO 2016



COPYRIGHT PROTECTED DOCUMENT

© ISO 2016, Published in Switzerland

All rights reserved. Unless otherwise specified, no part of this publication may be reproduced or utilized otherwise in any form or by any means, electronic or mechanical, including photocopying, or posting on the internet or an intranet, without prior written permission. Permission can be requested from either ISO at the address below or ISO's member body in the country of the requester.

ISO copyright office
Ch. de Blandonnet 8 • CP 401
CH-1214 Vernier, Geneva, Switzerland
Tel. +41 22 749 01 11
Fax +41 22 749 09 47
copyright@iso.org
www.iso.org

Contents

Page

Foreword	iv
1 Scope	1
2 Terms and definitions	1
2.1 Basic definitions	1
2.2 Masses	1
2.3 Main machine dimensions	2
2.4 Loader dimensions	6
2.5 Bogie and load space dimensions	7
3 Required information	8
Bibliography	12

Foreword

ISO (the International Organization for Standardization) is a worldwide federation of national standards bodies (ISO member bodies). The work of preparing International Standards is normally carried out through ISO technical committees. Each member body interested in a subject for which a technical committee has been established has the right to be represented on that committee. International organizations, governmental and non-governmental, in liaison with ISO, also take part in the work. ISO collaborates closely with the International Electrotechnical Commission (IEC) on all matters of electrotechnical standardization.

The procedures used to develop this document and those intended for its further maintenance are described in the ISO/IEC Directives, Part 1. In particular the different approval criteria needed for the different types of ISO documents should be noted. This document was drafted in accordance with the editorial rules of the ISO/IEC Directives, Part 2 (see www.iso.org/directives).

Attention is drawn to the possibility that some of the elements of this document may be the subject of patent rights. ISO shall not be held responsible for identifying any or all such patent rights. Details of any patent rights identified during the development of the document will be in the Introduction and/or on the ISO list of patent declarations received (see www.iso.org/patents).

Any trade name used in this document is information given for the convenience of users and does not constitute an endorsement.

For an explanation on the meaning of ISO specific terms and expressions related to conformity assessment, as well as information about ISO's adherence to the WTO principles in the Technical Barriers to Trade (TBT) see the following URL: [Foreword - Supplementary information](#)

The committee responsible for this document is ISO/TC 23, *Tractors and machinery for agriculture and forestry*, Subcommittee SC 15, *Machinery for forestry*.

This second edition cancels and replaces the first edition (ISO 13860:2000), which has been technically revised. In this edition, some definitions have been modified, machine masses are defined broader, and some technical and editorial errors have been corrected.

Machinery for forestry — Forwarders — Terms, definitions and commercial specifications

1 Scope

This International Standard specifies terminology and required information as a general framework for identifying and describing the main dimensions and features of wheeled forwarders.

It is applicable to articulated wheeled forwarders (as defined in ISO 6814, a forwarder is a self-propelled machine designed to move trees or parts of trees by carrying them).

2 Terms and definitions

2.1 Basic definitions

2.1.1

front

defined for the primary direction of the travel; the primary driving direction

2.1.2

rear

defined for the primary direction of the travel; the opposite *front* ([2.1.1](#)), wherein the load space is in the rear of the machine

2.1.3

right hand side

operator's right hand side when driving in the primary driving direction and with the machine in its primary functional mode

2.1.4

left hand side

opposite side of the machine to the *right hand side* ([2.1.3](#))

2.1.5

ground reference plane**GRP**

hard, flat, horizontal surface on which the machine is placed for measurements

2.2 Masses

NOTE 1 Adapted from ISO 6016.

NOTE 2 Masses are expressed in kilograms.

2.2.1

operating mass**OM**

mass of the base machine with equipment and empty attachment as specified by the manufacturer, and with the operator (75 kg), full fuel tank and all fluid systems at the levels specified by the manufacturer

2.2.2

rated paymass

rated payload

PM

manufacturer's rated mass that can be carried by the machine

2.2.3

gross machinery mass

GMM

combined mass of the *operating mass (OM)* ([2.2.1](#)) of the machine and the *rated paymass (PM)* ([2.2.2](#))

2.2.4

axle distribution of masses of wheeled machines

load on each axle at *operating mass (OM)* ([2.2.1](#))

Note 1 to entry: See [2.2.1](#).

2.2.4.1

axle load

load on each axle at *operating mass (OM)* ([2.2.1](#))

2.2.4.2

maximum permissible axle load

maximum load on each axle specified by the manufacturer

2.2.5

shipping mass

SM

mass of the base machine without an operator, and with fuel level at 10 % of tank capacity, all fluid systems at their levels specified by the manufacturer and with or without equipment, attachment, cab, canopy, ROPS and/or FOPS, wheels and counterweights as stated by the manufacturer

Note 1 to entry: If the machine has to be disassembled for shipping purposes, the masses of these dismantled components shall be stated by the manufacturer.

2.2.6

cab mass

mass of a cab with all its components and the moorings required to secure it to the base machine

2.2.7

canopy mass

mass of a canopy with all its components and the moorings required to secure it to the base machine

2.2.8

ROPS mass

mass of an ROPS with all its components and the moorings required to secure it to the base machine

2.2.9

FOPS mass

mass of an FOPS with all its components and the moorings required to secure it to the base machine

2.3 Main machine dimensions

2.3.1

total frame length

l_1

horizontal distance between the vertical planes perpendicular to the longitudinal axis passing through the farthest points on the front and rear frame of the machine, blade and loader excluded

Note 1 to entry: See [Figure 1](#).

2.3.2**overall length** l_2

horizontal distance from a vertical plane touching the forward-most point of the machine, blade positioned to give maximum forward reach (if so equipped), to a vertical plane touching the rearmost point of the machine, loader excluded

Note 1 to entry: See [Figure 1](#).

2.3.3**wheelbase** l_3

horizontal distance from the centre of the front axle or front bogie axle assembly to the centre of the rear axle or rear bogie axle assembly when both axles are perpendicular to the longitudinal axis

Note 1 to entry: See [Figure 1](#).

2.3.4**articulation joint to maximum blade arc** l_4

horizontal distance from the centreline of the articulation joint to a vertical line tangent to the arc of the blade's lower edge as it passes from its maximum height h_4 to the *lowest blade position* h_5 ([2.3.12](#))

Note 1 to entry: See [Figure 1](#).

2.3.5**articulation joint to front of machine** l_5

horizontal distance from the centreline of the articulation joint to a vertical plane touching the farthest point forward, blade excluded

Note 1 to entry: See [Figure 1](#).

2.3.6**articulation joint to front axle** l_6

horizontal distance from the centreline of the articulation joint to the centre of the front axle or front bogie axle assembly

Note 1 to entry: See [Figure 1](#).

2.3.7**overall height** h_1

horizontal distance from the centreline of the articulation joint to the centre of the front axle or front bogie axle assembly

Note 1 to entry: See [Figure 1](#).

2.3.8**operator cab overall height** h_2

height of the operator cab frame with rigid attachments

Note 1 to entry: See [Figure 1](#).

2.3.9

blade height

h_3
vertical distance from the lower edge, resting on the *GRP* (2.1.5), to the top of the blade, decking lugs excluded

Note 1 to entry: See [Figure 1](#).

2.3.10

blade width

w_3
horizontal distance between the outer edges of the blade

Note 1 to entry: See [Figure 3](#).

2.3.11

maximum blade lift lower edge

h_4
maximum vertical height to which the lower edge of the blade can be raised from the *GRP* (2.1.5)

Note 1 to entry: See [Figure 1](#).

2.3.12

lowest blade position

h_5
vertical distance from the *GRP* (2.1.5) to the blade's lower edge with blade at its lowest position

Note 1 to entry: See [Figure 1](#).

2.3.13

ground clearance

h_6
vertical distance from the *GRP* (2.1.5) to the machine centre portion, i.e. 25 % of the track width either side of the longitudinal centreline

Note 1 to entry: See [Figure 2](#).

2.3.14

ground clearance at articulation joint

h_7
vertical distance from the *GRP* (2.1.5) to the lowest point at the articulation joint

Note 1 to entry: See [Figure 1](#).

2.3.15

loaded tire radius

r_1
vertical distance from the *GRP* (2.1.5) to the horizontal centre of the axle with the machine at normal *operating mass (OM)* (2.2.1)

Note 1 to entry: See [Figure 1](#).

2.3.16

articulation joint to the axis of loader rotation

l_7
horizontal distance from the centreline of the articulation joint to the centreline of the vertical axis of loader rotation along the longitudinal axis of the machine

Note 1 to entry: See [Figure 1](#).

2.3.17

distance of load bunk headboard to rear axle
distance of load bunk front guard to rear axle

 l_8

horizontal distance from the load side of the headboard to the centre of rear axle or to rear bogie axle assembly

Note 1 to entry: See [Figure 1](#).

2.3.18

distance of load bunk headboard to rearmost bunk
distance of load bunk front guard to rearmost bunk

 l_9

horizontal distance from the load side of the headboard to the rear of the rearmost position of adjustable bunk

Note 1 to entry: See [Figure 1](#).

2.3.19

overall width

 w_1

horizontal distance between two vertical planes parallel to the longitudinal axis of the machine and passing through the farthest points on the two sides of this axis

Note 1 to entry: See [Figure 2](#).

2.3.20

trackwidth

 w_2

horizontal distance between two parallel vertical planes passing through the centreline of the tires on an axle

Note 1 to entry: If the front and rear are different, both must be specified.

Note 2 to entry: See [Figure 2](#).

2.3.21

frame oscillation angle

 a_1

angle that one frame will rotate from a horizontal datum, in both directions, without rotating the other frame, measured in degrees

Note 1 to entry: See [Figure 2](#).

2.3.22

axle oscillation angle

 a_2

angle that one axle will rotate from a horizontal datum, in both directions, without rotating either frame, measured in degrees

Note 1 to entry: See [Figure 2](#).

2.3.23

clearance circle

 d_1

diameter of the smallest circle that the outermost point on the machine will describe when turning (brakes unapplied, blade in uppermost position, unloaded)

Note 1 to entry: See [Figure 3](#).

2.3.24

angle of articulation

a_3
maximum angle of frame steering movement from the straight ahead position measured in degrees between longitudinal centrelines of the front and rear frames

Note 1 to entry: Quantify both left and right if unequal.

Note 2 to entry: See [Figure 3](#).

2.4 Loader dimensions

2.4.1

loader tilt

aa_1
maximum angle between the axis of loader rotation and vertical line, on loaders with a tilting base

Note 1 to entry: Specify direction if unequal.

Note 2 to entry: See [Figure 1](#).

2.4.2

loader rotation

aa_2
maximum loader horizontal rotation from the longitudinal centreline of the machine, measured in degrees

Note 1 to entry: Specify if continuous rotation, quantify both right and left if unequal.

Note 2 to entry: See [Figure 3](#).

2.4.3

maximum loader reach

ll_1
maximum horizontal distance from the loader axis of rotation to the centreline of the grapple yoke

Note 1 to entry: See [Figure 4](#).

2.4.4

maximum loader reach at ground level

ll_2
maximum horizontal distance from the loader axis of rotation to the grapple yoke with the open grapple resting on the *GRP* (2.1.5), measured when loader oriented 90 degrees sideways from the machine axis

Note 1 to entry: See [Figure 4](#).

2.4.5

maximum loader lift height

hh_1
maximum vertical lift height from the *GRP* (2.1.5) to the bottom of the grapple in tip-to-tip condition at a specified horizontal radius from the axis of rotation

Note 1 to entry: See [Figure 4](#).

2.4.6

loading height of loader at maximum reach

hh_2
vertical distance from the *GRP* (2.1.5) to the bottom of the grapple in tip-to-tip condition with the loader at the maximum horizontal reach (EE)

Note 1 to entry: See [Figure 4](#).

2.4.7**maximum depth of loader***hh₃*

maximum depth below the *GRP* (2.1.5) to the bottom of the grapple in tip-to-tip condition at a specified horizontal radius from the loader axis of rotation

Note 1 to entry: See [Figure 4](#).

2.4.8**grapple height closed***hh₄*

vertical distance between the centreline of the boom pivot of the grapple yoke and the bottom of the grapple in tip-to-tip condition

Note 1 to entry: See [Figure 4](#).

2.4.9**grapple height open***hh₅*

vertical distance between the centreline of the boom pivot of the grapple yoke and the tips of the fully open grapple

Note 1 to entry: See [Figure 4](#).

2.4.10**area of grapple opening**

A

cross-sectional area of the grapple opening in the tip-to-tip position

Note 1 to entry: See [Figure 4](#).

2.4.11**height of main boom pivot***hh₆*

vertical distance between the *GRP* (2.1.5) and the horizontal axis of the main boom pivot

Note 1 to entry: See [Figure 4](#).

2.5 Bogie and load space dimensions**2.5.1****bogie axle assembly centreline distance***ll₃*

horizontal distance from the centreline of the bogie axle to the centreline of the front or rear tire of the bogie axle assembly

Note 1 to entry: See [Figure 5](#).

2.5.2**bogie axle assembly wheelbase***ll₄*

horizontal distance between the centrelines of the front and rear tire of the bogie axle assembly

Note 1 to entry: See [Figure 5](#).

2.5.3**bogie axle assembly wheelbase angle***aa₃*

angle that the bogie axle assembly can rotate from a horizontal datum

Note 1 to entry: See [Figure 5](#).

2.5.4

cross-sectional area of load space

AA
effective area of the load space in a vertical plane perpendicular to the longitudinal axis of the machine with the height of the load defined by the height of the stakes or the headboard, whichever is lower

Note 1 to entry: See [Figure 6](#).

2.5.5

width across stakes

ww₁
horizontal distance between the load side of the stakes

Note 1 to entry: See [Figure 6](#).

2.5.6

stake height

hh₇
vertical distance from the GRP ([2.1.5](#)) to the top of the stakes

Note 1 to entry: See [Figure 6](#).

2.5.7

height of load centre

hh₈
vertical distance from the GRP ([2.1.5](#)) to the centroid of the effective area of the load space

Note 1 to entry: See [Figure 6](#).

3 Required information

In addition to the identification of relevant dimensions and features as defined in [Clause 2](#), the following information shall be supplied where appropriate:

- tyre size;
- ply rating;
- inflation pressure;
- possible hydro-inflation;
- maximum and minimum for adjustable dimensions, e.g. stake height ([2.5.6](#));
- unequal front/rear or left/right for asymmetrical dimensions, e.g. track width ([2.3.20](#)), angle of articulation ([2.3.24](#)), loader tilt ([2.4.1](#)), loader rotation ([2.4.2](#));
- continuous or in steps, e.g. loader rotation ([2.4.2](#)).

NOTE 1 [Figure 1](#) to [Figure 6](#) are for illustrative purposes only and are not intended to depict specific machines.

NOTE 2 All dimensions are with the axles parallel, and articulation joint angle 0°, unless otherwise specified.

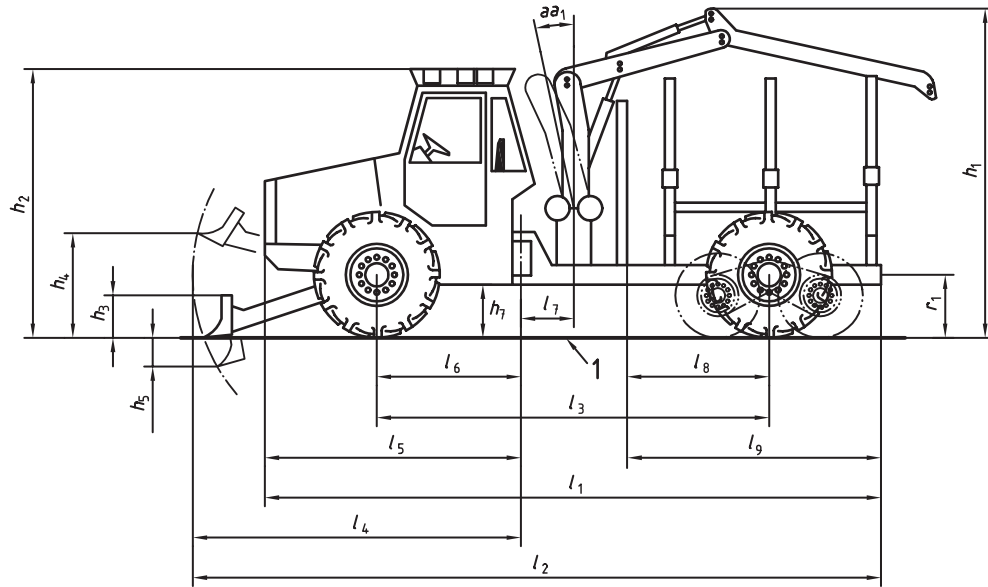

Key

- 1 ground reference plane

Figure 1 — Articulated rubber-tired forwarder

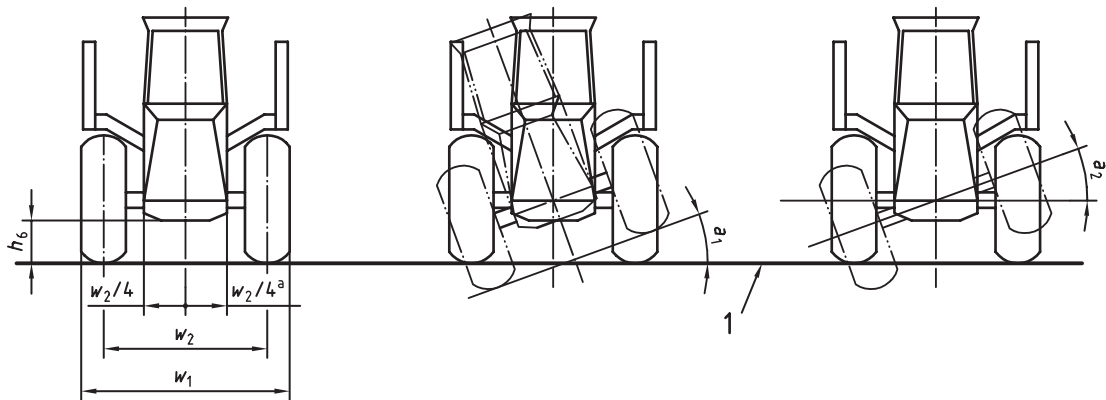

Key

- 1 ground reference plane

Figure 2 — Width, ground clearance and oscillation

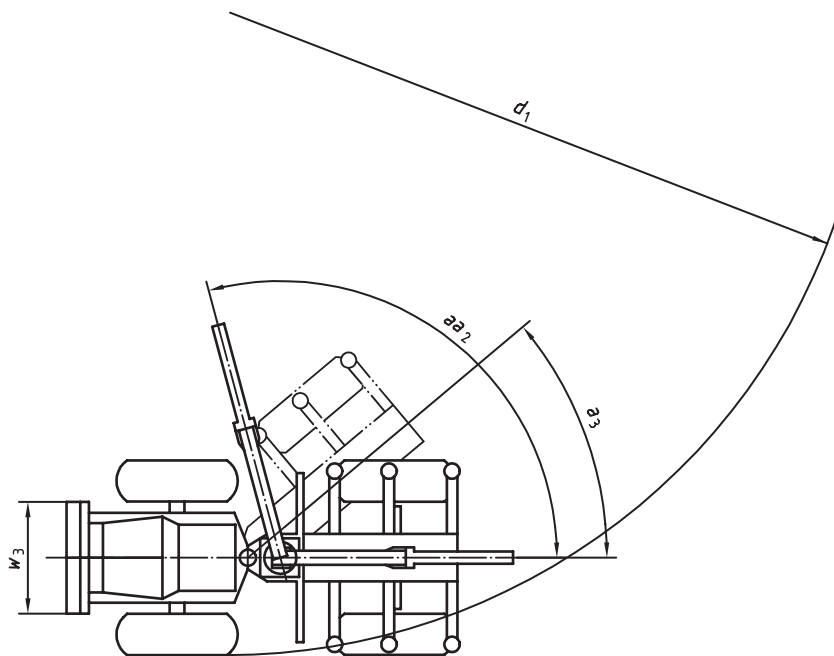
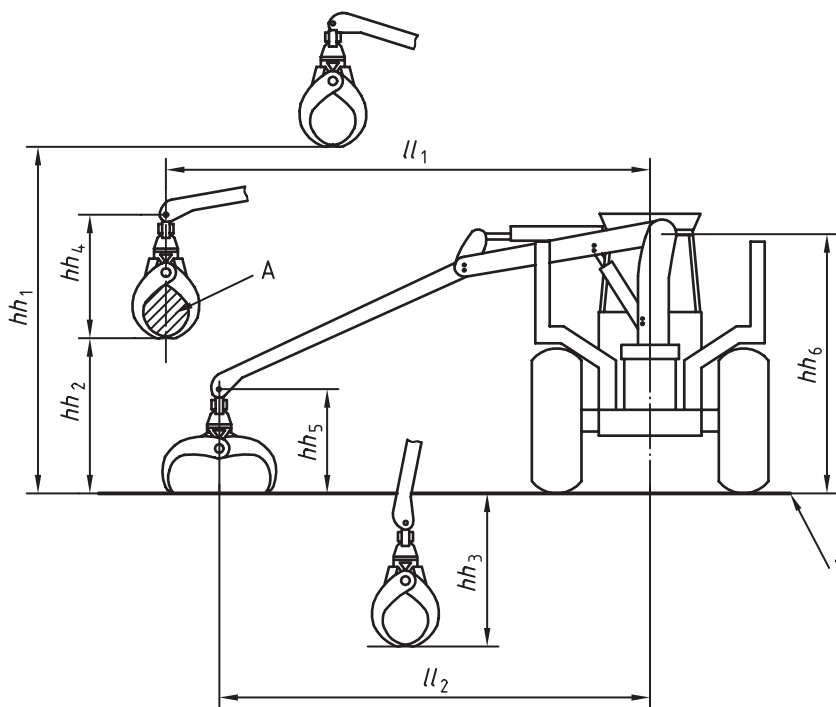

Figure 3 — Steering and loader rotation



Key

1 ground reference plane

Figure 4 — Loader specifications

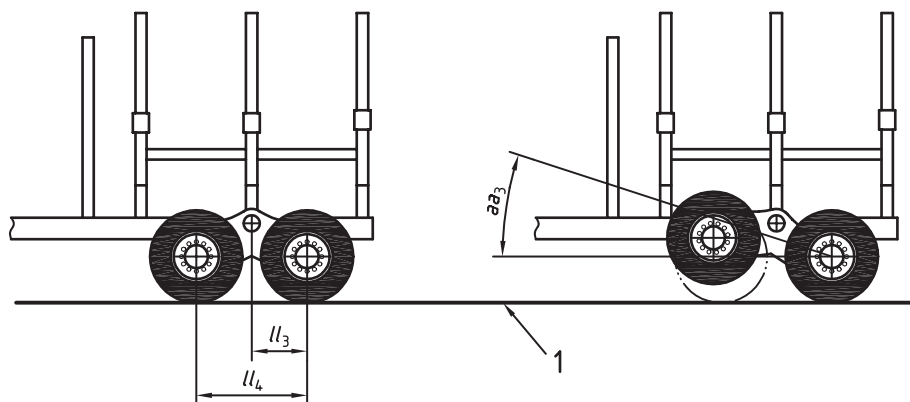

Key

1 ground reference plane

Figure 5 — Bogie specifications

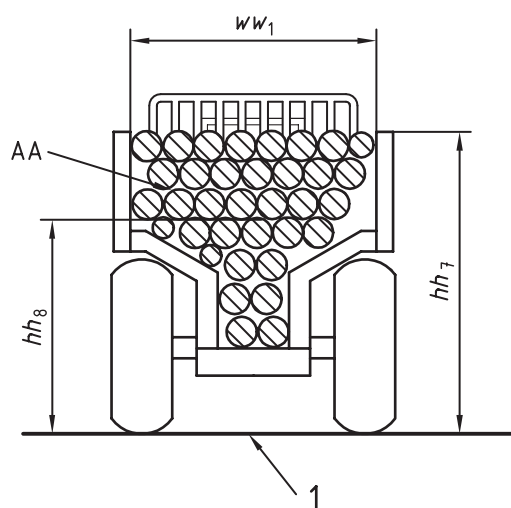

Key

1 ground reference plane

Figure 6 — Bunk specifications

Bibliography

- [1] ISO 6814, *Machinery for forestry — Mobile and self-propelled machinery — Terms, definitions and classification*

