

# INTERNATIONAL STANDARD

# ISO 13851

First edition  
2002-03-15

---

---

## **Safety of machinery — Two-hand control devices — Functional aspects and design principles**

*Sécurité des machines — Dispositifs de commande bimanuelle — Aspects  
fonctionnels et principes de conception*



Reference number  
ISO 13851:2002(E)

© ISO 2002

**PDF disclaimer**

This PDF file may contain embedded typefaces. In accordance with Adobe's licensing policy, this file may be printed or viewed but shall not be edited unless the typefaces which are embedded are licensed to and installed on the computer performing the editing. In downloading this file, parties accept therein the responsibility of not infringing Adobe's licensing policy. The ISO Central Secretariat accepts no liability in this area.

Adobe is a trademark of Adobe Systems Incorporated.

Details of the software products used to create this PDF file can be found in the General Info relative to the file; the PDF-creation parameters were optimized for printing. Every care has been taken to ensure that the file is suitable for use by ISO member bodies. In the unlikely event that a problem relating to it is found, please inform the Central Secretariat at the address given below.

© ISO 2002

All rights reserved. Unless otherwise specified, no part of this publication may be reproduced or utilized in any form or by any means, electronic or mechanical, including photocopying and microfilm, without permission in writing from either ISO at the address below or ISO's member body in the country of the requester.

ISO copyright office  
Case postale 56 • CH-1211 Geneva 20  
Tel. + 41 22 749 01 11  
Fax + 41 22 749 09 47  
E-mail [copyright@iso.ch](mailto:copyright@iso.ch)  
Web [www.iso.ch](http://www.iso.ch)

Printed in Switzerland

# Contents

Page

Foreword.....	v
Introduction.....	vi
1 Scope .....	1
2 Normative references .....	1
3 Terms and definitions .....	2
4 Types of two-hand control device and their selection .....	4
5 Characteristics of safety functions.....	4
5.1 Use of both hands (simultaneous actuation).....	4
5.2 Relationship between input signals and output signal .....	5
5.3 Cessation of the output signal .....	5
5.4 Prevention of accidental operation.....	5
5.5 Prevention of defeat .....	5
5.6 Re-initiation of the output signal .....	5
5.7 Synchronous actuation.....	5
6 Requirements related to categories of control.....	6
6.1 Category selection.....	6
6.2 Use of category 1 .....	6
6.3 Use of category 3.....	7
6.4 Use of category 4.....	7
7 Use of programmable electronic systems .....	7
8 Prevention of accidental actuation and of defeat .....	7
8.1 Common considerations.....	7
8.2 Prevention of defeat using one hand .....	8
8.3 Prevention of defeat using the hand and elbow of the same arm.....	8
8.4 Prevention of defeat using the forearm(s) or elbow(s).....	8
8.5 Prevention of defeat using one hand and any other part of the body (e.g. knee, hip).....	9
8.6 Prevention of defeat by blocking one control actuating device .....	9
8.7 Accidental actuation.....	9
9 General requirements.....	9
9.1 Ergonomic requirements .....	9
9.2 Operating conditions and environmental influences .....	10
9.3 Enclosures .....	10
9.4 Selection, design and installation of control actuating devices .....	10
9.5 Prevention of unintended output signals by acceleration forces .....	10
9.6 Unintended operation of mobile and portable hand-held machines.....	10
9.7 Mobile two-hand control devices .....	11
9.8 Safety distance .....	11
10 Verification .....	12
10.1 General requirements for verification .....	12
10.2 Visual inspection .....	13
10.3 Performance check.....	13
10.4 Measurement.....	13
10.5 Prevention of defeat .....	13
11 Marking .....	13
12 Information for installation, use and maintenance .....	14
12.1 Provision of information .....	14

<b>12.2</b>	<b>Installation instructions .....</b>	<b>14</b>
<b>12.3</b>	<b>Instructions for use .....</b>	<b>15</b>
<b>12.4</b>	<b>Maintenance instructions .....</b>	<b>15</b>
<b>Annex A</b>	<b>(normative) Measurement test for the prevention of defeat .....</b>	<b>16</b>
<b>Annex B</b>	<b>(informative) Use of categories (in accordance with ISO 13849-1) in types of two-hand control device .....</b>	<b>21</b>
<b>Annex C</b>	<b>(informative) Relationship between International Standards referenced in clause 2 and corresponding European Standards .....</b>	<b>22</b>
<b>Bibliography</b>	<b>.....</b>	<b>23</b>

## Foreword

ISO (the International Organization for Standardization) is a worldwide federation of national standards bodies (ISO member bodies). The work of preparing International Standards is normally carried out through ISO technical committees. Each member body interested in a subject for which a technical committee has been established has the right to be represented on that committee. International organizations, governmental and non-governmental, in liaison with ISO, also take part in the work. ISO collaborates closely with the International Electrotechnical Commission (IEC) on all matters of electrotechnical standardization.

International Standards are drafted in accordance with the rules given in the ISO/IEC Directives, Part 3.

The main task of technical committees is to prepare International Standards. Draft International Standards adopted by the technical committees are circulated to the member bodies for voting. Publication as an International Standard requires approval by at least 75 % of the member bodies casting a vote.

Attention is drawn to the possibility that some of the elements of this International Standard may be the subject of patent rights. ISO shall not be held responsible for identifying any or all such patent rights.

International Standard ISO 13851 was prepared by Technical Committee ISO/TC 199, *Safety of machinery*.

Annex A forms a normative part of this International Standard. Annexes B and C are for information only.

## Introduction

A two-hand control device is a safety device (safety component). It provides a measure of protection for the operator against reaching danger zones during hazardous situations by locating the control actuating devices in a specific position. For hand-held machinery, it should be taken into consideration that the danger zone is not stationary.

The selection of a two-hand control device as an appropriate safety device will depend upon the risk assessment made by designers, standard makers and others in accordance with ISO/TR 12100-1 and ISO 14121.

The definition of a two-hand control device is given in 3.1 and takes precedence over the definition given in ISO/TR 12100-1:1992, 3.23.4.

In some arrangements, enabling devices (see ISO/TR 12100-1:1992, 3.23.2) and/or hold-to-run devices (see ISO/TR 12100-1:1992, 3.23.3) may comply with the definition of a two-hand control device in this International Standard. Additionally, some special control devices — such as teach pendants for robots and some crane controls — require the use of two hands and can comply with the definition of a two-hand control device in this International Standard.

This International Standard has been prepared as a harmonized standard in the sense of the Machinery Directive of the European Union and the rules of the European Free Trade Association (EFTA) which are associated with it. This International Standard is based on EN 574:1996, published by the European Committee for Standardization (CEN).

.....

# Safety of machinery — Two-hand control devices — Functional aspects and design principles

## 1 Scope

This International Standard specifies the safety requirements of a two-hand control device and the dependency of the output signal from the input signals.

This International Standard describes the main characteristics of two-hand control devices for the achievement of safety and sets out combinations of functional characteristics for three types. It does not apply to devices intended to be used as enabling devices, as hold-to-run devices or as special control devices.

This International Standard does not specify with which machines two-hand control devices shall be used. It also does not specify which types of two-hand-control device shall be used. Moreover, it does not specify the distance between the two-hand control device and the danger zone (see 9.8).

This International Standard provides requirements and guidance on the design and selection (based on a risk assessment) of two-hand control devices including their assessment, the prevention of defeat and the avoidance of faults. It also provides requirements and guidance for two-hand control devices containing a programmable electronic system (see clause 7).

This International Standard applies to all two-hand control devices, independent of the energy used, including:

- two-hand control devices which are or are not integral parts of a machine;
- two-hand control devices which consist of one or more than one separate element.

## 2 Normative references

The following normative documents contain provisions which, through reference in this text, constitute provisions of this International Standard. For dated references, subsequent amendments to, or revisions of, any of these publications do not apply. However, parties to agreements based on this International Standard are encouraged to investigate the possibility of applying the most recent editions of the normative documents indicated below. For undated references, the latest edition of the normative document referred to applies. Members of ISO and IEC maintain registers of currently valid International Standards.

ISO/TR 12100-1:1992, *Safety of machinery — Basic concepts, general principles for design — Part 1: Basic terminology, methodology*

ISO/TR 12100-2:1992, *Safety of machinery — Basic concepts, general principles for design — Part 2: Technical principles and specifications*

ISO 13849-1:1999, *Safety of machinery — Safety-related parts of control systems — Part 1: General principles for design*

ISO 13855:2002, *Safety of machinery — Positioning of protective equipment with respect to the approach speeds of parts of the human body*

ISO 14121, *Safety of machinery — Principles of risk assessment*

IEC 60204-1:1997, *Safety of machinery — Electrical equipment of machines — Part 1: General requirements*

EN 894-3, *Safety of machinery — Ergonomics requirements for the design of displays and control actuators — Part 3: Control actuators*

### 3 Terms and definitions

For the purposes of this International Standard, the following terms and definitions apply.

#### 3.1

##### two-hand control device

a device which requires at least simultaneous actuation by the use of both hands in order to initiate and to maintain, whilst a hazardous condition exists, any operation of a machine thus affording a measure of protection only for the person who actuates it

See Figure 1.

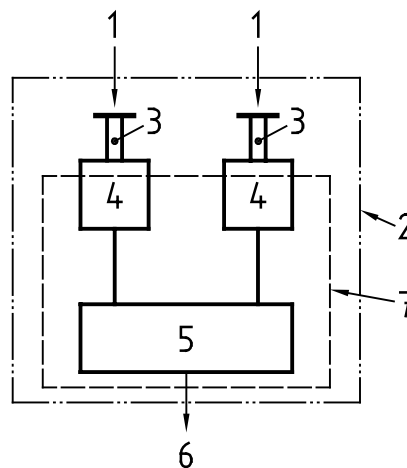

#### Key

- |   |                          |   |                     |
|---|--------------------------|---|---------------------|
| 1 | Input signal             | 5 | Signal processor(s) |
| 2 | Two-hand control device  | 6 | Output signal       |
| 3 | Control actuating device | 7 | Logic unit          |
| 4 | Signal converter(s)      |   |                     |

Figure 1 — Schematic representation of a two-hand control device

#### 3.2

##### input signal

the externally actuated signal applied by hand to a control-actuating device

See Figure 1.



**3.3****control actuating device**

a component of the two-hand control device which senses an input signal from one hand and transmits it to a signal converter

See Figure 1.

**3.4****simultaneous actuation**

the continuing actuation of both control actuating devices during the same time period, whatever the time lag is between the start of one input signal and the start of the other

See Figure 2.

NOTE In the English language, the word “concurrent” and the word “simultaneous” are often used synonymously (see e.g. IEC60204-1:1997, 9.2.5.7).

**3.5****synchronous actuation**

a particular case of simultaneous actuation where the time lag between the start of one input signal and the start of the other is less than or equal to 0,5 s

See Figure 3.

**3.6****signal converter**

a component of the two-hand control device which receives an input signal from a control actuating device and which transmits and/or converts this signal into a form acceptable to the signal processor

See Figure 1.

**3.7****signal processor**

a part of the two-hand control device which generates the output signal as a consequence of the two input signals

See Figure 1.

**3.8****output signal**

the signal generated by the two-hand control device to be fed into the machinery to be controlled, and which is based on one pair of input signals

See Figure 1.

**3.9****response time**

the time between the release of a control actuating device and the cessation of the output signal

See also 9.8.

**3.10****mobile two-hand control device**

a device which can be moved and used in more than one definable position relative to the danger zone of the machine which it controls

## 4 Types of two-hand control device and their selection

Table 1 defines three types of two-hand control device. It sets out the functional characteristics and the minimum measures for the safety of each type of two-hand control device in this International Standard. All two-hand control devices shall comply with ISO/TR 12100 and with IEC 60204-1.

**Table 1 — List of types of two-hand control device and minimum safety requirements**

Requirements	Subclause	Type				
		I	II	III		
				A	B	C
Use of both hands (simultaneous actuation)	5.1	X	X	X	X	X
Relationship between input signals and output signal	5.2	X	X	X	X	X
Cessation of the output signal	5.3	X	X	X	X	X
Prevention of accidental operation	5.4	X	X	X	X	X
Prevention of defeat	5.5	X	X	X	X	X
Re-initiation of the output signal	5.6	a	X	X	X	X
Synchronous actuation	5.7			X	X	X
Use of category 1 (see ISO 13849-1)	6.2	X		X		
Use of category 3 (see ISO 13849-1)	6.3		X		X	
Use of category 4 (see ISO 13849-1)	6.4					X

<sup>a</sup> For the selection of type I, see 8.6.

The selection and the design of the type (see Table 1) of two-hand control device will depend on

- the hazard(s) present;
- the risk assessment;
- experience in use of the technology;
- other factors, which shall be specified for each application [e.g. the prevention of accidental actuation and of defeat (see clause 8), as well as other conditions (see ISO/TR 12100-2:1992, clause 3)].

NOTE Guidance on risk assessment may be found in ISO/TR 12100-1 and detailed guidance is given in ISO 14121.

## 5 Characteristics of safety functions

The characteristics of safety functions described in 5.1 to 5.7 shall be included in two-hand control devices in accordance with Table 1.

### 5.1 Use of both hands (simultaneous actuation)

The two-hand control device shall be designed so that the operator must use both hands during the same time period, one hand on each control-actuating device, to operate the two-hand control device. This is simultaneous actuation and is independent of any time lag between the initiation of each of the two input signals (see Figure 2).

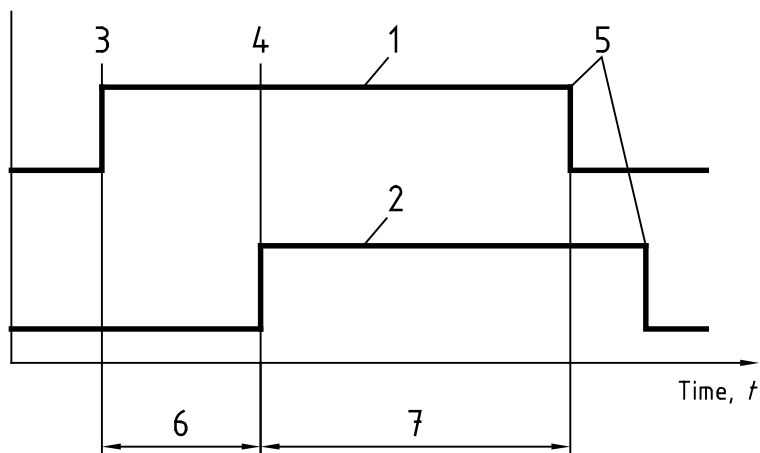

### Key

- |   |                                   |   |  |
|---|-----------------------------------|---|--|
| 1 | First hand                        | 5 | Cessation of input signals                 |
| 2 | Second hand                       | 6 | Time lag undefined, simultaneous actuation |
| 3 | Initiation of first input signal  | 7 | Time period of simultaneous actuation      |
| 4 | Initiation of second input signal |   |  |

**Figure 2 — Input signals in the case of simultaneous actuation**

## 5.2 Relationship between input signals and output signal

The input signals applied to each of the two control actuating devices shall together initiate and maintain the output signal from the two-hand control device only so long as both input signals are applied. The form of the output signal (e.g. number of channels, pulse, shape, etc.) may vary depending on the design requirements in each case. It shall always be regarded as, and shall be identified as, a single output signal by the machine control circuit.

## 5.3 Cessation of the output signal

The release of either one or both control actuating devices shall initiate the cessation of the output signal.

## 5.4 Prevention of accidental operation

The probability of operating the control actuating devices accidentally shall be minimized (see clauses 8 and 9).

## 5.5 Prevention of defeat

The protective effect of the two-hand control device shall not be easily defeated (see clauses 8 and 9).

## 5.6 Re-initiation of the output signal

The re-initiation of the output signal shall only be possible after the release of both control actuating devices.

## 5.7 Synchronous actuation

**5.7.1** An output signal shall be generated only when both control actuating devices are actuated in a time lag which is less than or equal to 0,5 s (see Figure 3).

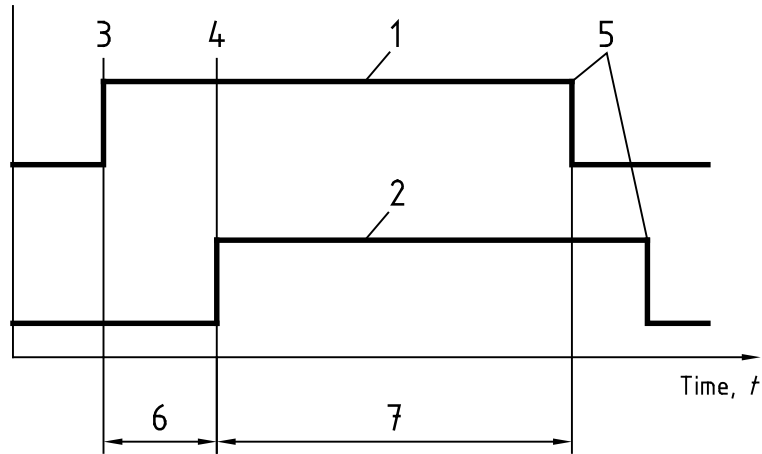

**Key**

- |   |                                   |   |  |
|---|-----------------------------------|---|--|
| 1 | First hand                        | 5 | Cessation of input signals                   |
| 2 | Second hand                       | 6 | Time lag $\leq 0,5$ s, synchronous actuation |
| 3 | Initiation of first input signal  | 7 | Time period of simultaneous actuation        |
| 4 | Initiation of second input signal |   |  |

**Figure 3 — Input signals in the case of synchronous actuation**

**5.7.2** Mechanical two-hand control devices shall only generate an output signal by satisfying particular spatial requirements for the travel of both of the control actuating devices.

**5.7.3** If the control actuating devices are not actuated synchronously, the output signal shall be prevented and it shall be necessary to release both control actuating devices and to re-apply both input signals.

**NOTE** Where two or more two-hand control devices are used to operate one machine, synchronous actuation is required only within each two-hand control device and is not required between devices.

## 6 Requirements related to categories of control

### 6.1 Category selection

The behaviour of parts of a two-hand control device in the case of failure shall be in accordance with the selected category of ISO 13849-1 (see Table 2).

The category of control of two-hand control devices shall not be less than the category of control of the relevant safety related part of the machine control system (see ISO 13849-1).

Annex B describes the relationship between the types of two-hand control devices and the categories according to ISO 13849-1.

### 6.2 Use of category 1

Well-ried safety components and safety principles in accordance with, at least, category 1 of ISO 13849-1 shall be used in type I and type IIIA two-hand control devices.

**NOTE** In order to achieve high reliability and high availability, it is recommended that well-ried safety components and safety principles be used in all types of two-hand control device.

### 6.3 Use of category 3

**6.3.1** When the risk assessment indicates the requirement for single-fault safety, type II and type IIIB two-hand control devices shall comply with category 3 (ISO 13849-1) and with 6.3.2, 6.3.3 and 6.3.4.

**6.3.2** A single fault in the two-hand control shall not lead to the loss of the safety function(s).

**6.3.3** The two-hand control device shall not be converted into a one-hand control device as a consequence of a single fault.

**6.3.4** An output signal shall not be generated as a consequence of a single fault.

**NOTE** These requirements do not mean that all faults will be detected. Consequently, the accumulation of undetected faults may lead to the loss of the safety function and to an unintended output of the two-hand control device.

### 6.4 Use of category 4

**6.4.1** When the risk assessment indicates the requirements for automatic monitoring, the type IIIC two-hand control device shall comply with category 4 (ISO 13849-1), with 6.3 and with 6.4.2, 6.4.3 and 6.4.4.

**6.4.2** A single fault shall be detected at or before the next operation of the safety function(s).

**6.4.3** After the occurrence of a single fault, it shall not be possible to re-initiate the output signal.

**6.4.4** An output signal being generated at the time of occurrence of a single fault may continue, but shall cease when either one or both input signals are terminated. If a single fault cannot be detected, then a combination of faults shall not lead to a loss of the safety function(s).

## 7 Use of programmable electronic systems

Where a programmable electronic system (PES) is used to achieve the functional characteristics of a two-hand control device, the safety requirements of the hardware and in the software of the PES shall be validated in accordance with the risk assessment.

Secure means shall be provided for the software and the hardware of the PES to ensure that the designed functional characteristics cannot be tampered with.

The output signal of type IIIB and type IIIC two-hand control devices shall not be generated and transferred solely by a single-channel PES to the machine control system.

**NOTE** There is still considerable development in the ways in which programmable electronic systems are being validated, and a list of documents which provide guidance in this subject area is given in annex C.

## 8 Prevention of accidental actuation and of defeat

### 8.1 Common considerations

The control actuating devices of a two-hand control device shall be designed and arranged in such a way that the protective effect of the two-hand control device cannot be easily defeated and that the probability of accidental actuation is minimized, in accordance with the risk assessment for the particular application.

The use of one hand alone, the use of possible combinations of one hand and/or other parts of the body and/or the use of simple aids which allow defeat shall all be considered, so that it shall not be possible to reach into the danger zone during a hazardous situation. Accidental actuation (e.g. by the clothes of the operator) shall be considered in the same way.

Simple aids can be e.g. bridges, cords or tapes. The selection of dissimilar actuating directions, covers, shapes, etc., shall minimize the possibilities of defeat. The possibility of a two-hand control device being operated by two persons, thus leaving two hands free, can be overcome by using synchronous actuation.

NOTE Total protection from “defeat” is not possible.

Subclauses 8.2 to 8.6 show some separate individual ways in which defeat is possible, together with some precautionary measures for prevention. The methods of defeat that shall be considered will depend upon the design of the two-hand control device, the operating conditions, the method of attachment and positioning of the two-hand control device and the specified safety distance requirements, etc.

Subclause 8.7 shows some ways of preventing accidental actuation.

The precautionary measures listed may be required singly or in combination to meet this International Standard. The test procedures which shall be applied to the most common types of design are set out in 10.5. For other designs of two-hand control device, these test procedures may or may not be applicable. In these cases, a hazard analysis and an assessment of the risk of the possible use and/or misuse of that design of two-hand control device shall be carried out and appropriate measures shall be taken to comply with this International Standard.

### 8.2 Prevention of defeat using one hand

Measures to prevent defeat by using one hand shall be provided. Examples of suitable measures are:

- separation of the control actuating devices by at least 260 mm (internal dimension);
- the provision of one or more shields or an elevated area between the control actuating devices, designed in such a way that the control actuating devices are separated by a distance of at least 260 mm around the shields.

### 8.3 Prevention of defeat using the hand and elbow of the same arm

Measures to prevent defeat by using the hand and elbow of the same arm shall be provided. Examples of suitable measures are:

- separation of the control actuating devices by at least 550 mm (internal dimension). For ergonomic reasons, this distance should not exceed 600 mm;
- the provision of one or more shields or an elevated area between the control actuating devices, designed in such a way that the control actuating devices cannot be touched by the elbow and the tips of the fingers of the same arm at the same time;
- the provision of covers designed in such a way that the control actuating devices cannot be operated by the elbow;
- the use of control actuating devices with different types and/or directions of operation.

### 8.4 Prevention of defeat using the forearm(s) or elbow(s)

Measures to prevent defeat by using the forearm(s) and/or elbow(s) shall be provided, if the distance of the hands from the hazard as a result of using forearm(s) and/or elbow(s) is smaller than the required safety distance.

A suitable measure is using covers and/or collars which are designed so that the control actuating devices cannot be operated by the forearm(s) and/or the elbow(s).

## 8.5 Prevention of defeat using one hand and any other part of the body (e.g. knee, hip)

Measures to prevent defeat by using other parts of the body in conjunction with one hand shall be provided. Examples of suitable measures are:

- Arrangement of the control actuating devices on a horizontal or nearly horizontal surface which is at least 1 100 mm above the floor or level of access. This is intended to prevent actuation by the hip.
- In the case of attachment to a vertical or near vertical surface, the provision of a protective collar around the control actuating devices.
- The provision of covers and/or shields which are designed in such a way that the control actuating devices cannot be operated by one hand and any other part of the body.

## 8.6 Prevention of defeat by blocking one control actuating device

Measures to prevent defeat by blocking one actuating device shall be provided.

This method of defeat causes a two-hand control device to become a one-hand control and may cause a permanent input signal to be generated by the blocked actuating device. This consequently may allow the output signal of the two-hand control device to be generated by using only one hand. Suitable measures to prevent this method of defeat are:

- To prevent re-initiation of the output signal for further operation by one hand, it shall be necessary to include the characteristic of re-initiation in the design of the two-hand control device (see 5.6).
- To prevent the first start by one hand, it shall be necessary to include the characteristic of synchronous operation in the design of the two-hand control device (see 5.7).

NOTE Whenever the selection of a type I two-hand control device is being considered, it is important to carry out the risk assessment carefully to determine whether the characteristics of synchronous operation and of re-initiation can be neglected.

## 8.7 Accidental actuation

The probability of accidental actuation of a two-hand control device shall be minimized.

The measures given in 8.2 to 8.6 will help to minimize accidental actuation. Other suitable measures to prevent accidental actuation are:

- For mechanical control actuating devices, the need for deliberate actuation with respect to the force and the travel required.
- For non-mechanical control actuating devices (e.g. photoelectric devices, capacitive devices), the need for sensitivity levels which will only allow deliberate actuation.

# 9 General requirements

## 9.1 Ergonomic requirements

There will sometimes be a conflict between good ergonomic principles (see EN 894-3) and the design of a two-hand control device in order to prevent defeat or accidental actuation (e.g. the size of openings and the need to wear gloves for certain operations).

Means and measures to achieve safety need to reflect the balance between

- the need to follow good ergonomic principles, and
- the need to provide measures to prevent defeat and accidental actuation.

The balance shall provide adequate safety for the particular risk.

## 9.2 Operating conditions and environmental influences

The parts of a two-hand control device shall be selected, installed and linked together in such a way that they withstand the operating stresses to be expected and fulfil the requirements of the relevant standards concerning such stresses (e.g. with regard to switching capacity and switching frequency) as well as the requirements of the relevant standards dealing with the environmental influences to be expected (e.g. vibration, impact, temperature, foreign bodies, moisture, oil and electromagnetic fields).

## 9.3 Enclosures

**9.3.1** Enclosures and their mountings shall be designed to withstand the expected operating and ambient stresses.

**9.3.2** Corners, edges, etc., shall be rounded or bevelled so as to avoid injury.

**9.3.3** Covers and parts which are intended to be removed or opened shall be constructed so that they can only be removed or opened with the aid of a tool. Fasteners shall be of the captive type.

**9.3.4** When enclosures are mounted on stands, the stands shall be provided with facilities for secure mounting to the enclosures and to the floor.

**9.3.5** Enclosures shall be mounted and positioned so that the operator, after releasing an actuator, cannot reach the danger zone during the hazardous situation (see 9.8 and 12.2).

**9.3.6** If the enclosure supporting the control actuating devices is adjustable, it shall be provided with means for locking it in position (for mobile two-hand control devices, see 9.7).

## 9.4 Selection, design and installation of control actuating devices

**9.4.1** Control actuating devices shall be selected, designed, arranged and installed in such a way that they can be actuated without undue fatigue (e.g. as a result of awkward posture, unsuitable movements or high operating forces) (see EN 894-3).

**9.4.2** Control actuating devices shall not be red.

NOTE For electrical two-hand control devices, see also IEC 60204-1.

**9.4.3** Control actuating devices shall not form any crushing or shearing points with any other parts.

**9.4.4** The two-hand control device, the relevant machine control system and their interconnection(s) shall be designed to corresponding categories as specified in ISO 13849-1.

## 9.5 Prevention of unintended output signals by acceleration forces

Foreseeable forces caused by acceleration imparted to the two-hand control device shall not cause an output signal (e.g. falling over, accidental impact or shockloading).

## 9.6 Unintended operation of mobile and portable hand-held machines

**9.6.1** A two-hand control device shall be designed to prevent its unintended operation due to the normal handling of the mobile and/or portable hand-held machine which it controls.

**9.6.2** A two-hand control device shall be designed so that separate and dissimilar actions of the control actuating devices are required to give the input signal to start the dangerous motion of the machine.



NOTE 1 The provision of the two control actuating devices in separate handles will not satisfy this requirement unless their method of operation is different.

NOTE 2 The provision of an automatic lock-out facility on one of the control actuating devices provides a higher level of protection.

## 9.7 Mobile two-hand control devices

**9.7.1** The actuators of a mobile two-hand control device, and their supporting enclosure, shall be stable in normal use (see ISO/TR 12100-2).

NOTE This may be fulfilled by including a large mass or any other suitable means.

**9.7.2** Mobile two-hand control devices shall be provided with means to prevent movement when being operated.

NOTE This may be fulfilled by including a large mass, use of lockable wheels or any other suitable means.

**9.7.3** Facilities shall be available for maintaining and checking the required safety distance between the control actuating devices and the danger zone (see 9.8 and 12.2) (e.g. by means of a distance ring — see Figure 4).

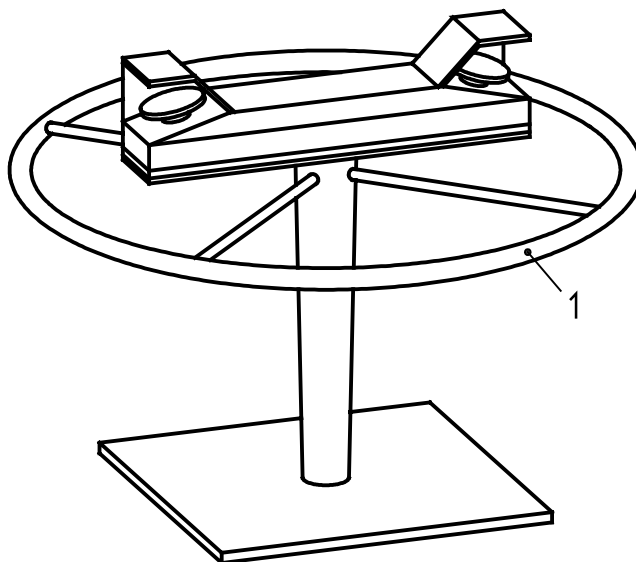

### Key

1 Distance ring

**Figure 4 — Example of a mobile two-hand control device with a distance ring**

**9.7.4** Pipes, cables and connections shall be protected against damage using the considerations presented in 9.2 and 9.4.4.

## 9.8 Safety distance

To calculate the required safety distance (referred to as the minimum distance in ISO 13855) between the control actuating devices and the danger zone, the following shall be taken into account:

- the hand/arm speed (see ISO 13855);
- the shape and arrangement of the two-hand control device;
- the response time of the two-hand control device;

- the maximum time taken to stop the machine, or remove the hazard, following cessation of the output signal of the two-hand control device;
- the intended use of the machine (see ISO/TR 12100-1);
- relevant type C standards.

## 10 Verification

### 10.1 General requirements for verification

The requirements specified for a two-hand control device, as identified by the risk assessment, shall be verified by theoretical assessment of the design and by practical tests. A summary of the verification procedures is given in Table 2. These procedures are intended to verify the safety requirements of the two-hand control device, including its functional characteristics.

**Table 2 — Verification procedure**

Clause	Safety requirements	Procedure			Remarks
		Visual inspection	Performance check	Measurement	
<b>General</b>					
9.2	Operating conditions and environmental influences		X	X	Apply relevant standards
9.3	Requirements on enclosures	X	X		By type testing
9.4	Selection, design and installation of control actuating devices	X	X	X	
9.5	Unintended output signal caused by acceleration forces		X	X	
9.6	Unintended control actuation	X	X		For mobile and portable hand-held machines
9.7	Stability		X		For mobile two-hand control devices
9.8	Response time			X	
11	Marking	X			
<b>Functional characteristics</b>					
5.1	Use of both hands	X	X		
5.2	Relationship input/output signal		X		
5.3	Cessation of output signal		X		
5.4	Accidental operation	X	X	X	Use the methods of clause 8
5.5	Defeating	X	X	X	By applying 10.5
5.6	Re-initiation		X		Resetting check
5.7	Synchronous operation Category of control		X	X	
6.2	Category 1	X			By identification
6.3	Category 3		X	X	Fault simulation (see 10.3)
6.4	Category 4		X	X	Fault simulation (see 10.3)

The verification procedures concern exclusively the two-hand control device itself and do not take into consideration the possible effect of the control system of the machinery to which the two-hand control device is connected. Feedback signal(s) from the machine control system which might eventually be required by the design of the two-hand control device shall be simulated.

The verification procedures that shall be considered will depend upon the design of the two-hand control device, the type of two-hand control device, the operating conditions, the method of attachment and positioning of the two-hand control device and the specific safety distance requirement, etc. These verification procedures include visual inspection, performance checking, measurement and theoretical assessment. This International Standard gives some guidance on test procedures, in particular on "prevention of defeat", but it does not specify detailed test methodologies.

The designer and/or the manufacturer shall arrange for the two-hand control device to be verified and/or type-tested so as to demonstrate that the device conforms to the design specifications. The requirements of these specifications may be given in standards (e.g. IEC 60204-1) or by the designer where no standard exists.

## 10.2 Visual inspection

Visual inspection is to verify the features required for the specific type of two-hand control device just by physical examination and shall be applied to the items listed in Table 2.

Any components used as well-tried components shall be specifically identified by the manufacturer.

## 10.3 Performance check

Performance checking is to verify the features required for the specific type of two-hand control device operation. The fault simulation is based on the fault analysis of the two-hand control device design. It includes simulation of all safety-related faults for type II, type IIIB and type IIIC (see Table 1 and Table 2).

## 10.4 Measurement

Measurement is to verify figures, binary signals, mechanical features, times, etc., specified by the designer to meet the requirements of this International Standard.

## 10.5 Prevention of defeat

Measurement tests for the prevention of defeat are given in annex A.

For the most common types of design, some or all of the measurement tests shall be applied (see also clause 8). The intended use and the shape of the two-hand control device will indicate which of the measurement tests in annex A are necessary since some of the measurement tests are contained within others and some are complementary.

These combinations of tests are intended to prevent defeat by using one hand only and also defeat by using one hand and the elbow, the knee, the hip, the thigh or the stomach.

## 11 Marking

**11.1** The requirements laid down both in ISO/TR 12100-2:1992, 5.4, and in ISO/TR 12100-2:1992, annex A, 1.7.3, shall be followed.

**11.2** A two-hand control device complying with this International Standard, and which is not an integral part of a machine, shall be labelled clearly and durably with the following details:

— The name and address of the manufacturer and/or responsible supplier.

- The manufacturer's model or type reference.
- The manufacturer's serial number and the year of manufacture.
- The type of two-hand control device in accordance with clause 4 and Table 1, and the number of this International Standard.

EXAMPLE

ISO 13851: Type IIIC

- The response time of the two-hand control device, as defined in 3.9.
- In the case of electrical two-hand control devices, the appropriate rating information (see IEC 60204-1).
- In the case of pneumatic, mechanical and other non-electrical two-hand control devices, the operating pressure and/or other relevant information.

**11.3** If the two-hand control device consists of two or more separate units, at least one unit shall be marked as required in 11.2. These units shall each be marked in such a way that they can be identified as parts of the same two-hand control device.

**11.4** In the case of a two-hand control device, complying with this International Standard, which is an integral part of a machine, at least the type of two-hand control device and the number of this International Standard shall be marked on the machine. Other instructions and the technical data for the two-hand control device shall be given in the machine instruction handbook.

NOTE This marking may be on the main machine marking plate or close to the control actuating devices.

**11.5** Components of two-hand control devices shall be identifiable, if necessary, for the purpose of maintenance and/or repair.

## **12 Information for installation, use and maintenance**

### **12.1 Provision of information**

The requirements laid down both in ISO/TR 12100-2:1992, 5.5, and in ISO/TR 12100-2:1992, annex A, 1.7.4, shall be followed.

Information shall be provided by the manufacturer or his authorized representative, in the official language(s) of the country in which the machine is to be used, on the installation, use and maintenance of the two-hand control device (see ISO/TR 12100-2:1992, clause 5).

The information may be given in the form of drawings, diagrams, tables and/or written information.

### **12.2 Installation instructions**

Unless the two-hand control device is an integral part of the machine, the following information shall be given:

- its physical dimensions;
- the space required for e.g. installation, inspection, maintenance, etc.;
- mounting details;
- an explanation as to how to determine the required safety distance (see 9.8);

- the value of the response time;
- the properties required, including guidance on selecting categories as specified in ISO 13849-1 for the correct interaction and interconnection between the two-hand control device and the relevant safety related part of the machine control system;
- the size and type of supply lines and interconnecting lines (e.g. cables, solid or flexible pipes and their recommended arrangement);
- details of protective devices (e.g. fuses or pressure-reducing valves);
- instructions for the initial start-up procedure;
- adjustment and setting instructions;
- test procedures to verify that the two-hand control device and the relevant parts of the machine control system are operating in the correct manner;
- details of any limitations on the intended use;
- details of provisions against foreseeable misuse.

### 12.3 Instructions for use

Instructions shall be given in clear and unambiguous language enabling the two-hand control device to be used correctly and safely.

Pictures, diagrams, symbols and figures shall be used where appropriate.

The instructions for use shall provide information to verify the correct functioning and to enable malfunctions to be recognized.

### 12.4 Maintenance instructions

The maintenance instructions shall contain:

- all information necessary for maintenance and repair (where appropriate, the instructions shall include drawings and circuit diagrams);
- appropriate safety instructions as a part of any schedule for maintenance and/or repair;
- a schedule for systematic maintenance;
- a parts list;
- a clear designation of the parts of the two-hand control device in accordance with the diagrams, drawings and descriptions.

## Annex A (normative)

### Measurement test for the prevention of defeat

#### A.1 General

Measurement tests A.2 to A.7 are the tests required in 10.5 to verify the measures required in clause 8. Figures A.1 to A.12 are illustrations of the principles given in the text for the prevention of defeat and do not represent all the details required for the design of a two-hand control device.

#### A.2 Prevention of defeat using one hand (see 8.2)

**A.2.1** Separation of the control actuating devices by a distance equal to or greater than 260 mm (see Figure A.1).

Dimensions in millimetres

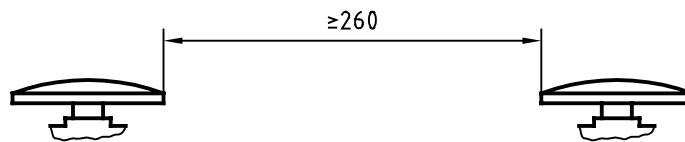

**Figure A.1 — Separation by distance**

**A.2.2** Separation of the control actuating devices by one or more shields or an elevated area designed in such a way that the control actuating devices cannot be touched with the ends of a 260 mm cord representing the finger-span (see Figure A.2).

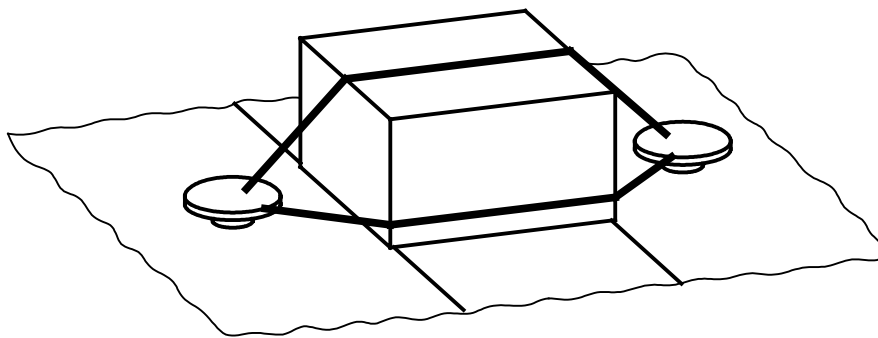

**Figure A.2 — Separation by an elevated area**

**A.2.3** Separation of the control actuation devices by collars and by orientation in such a way that the control actuating devices cannot be touched with the ends of a 260 mm cord (see Figure A.3).

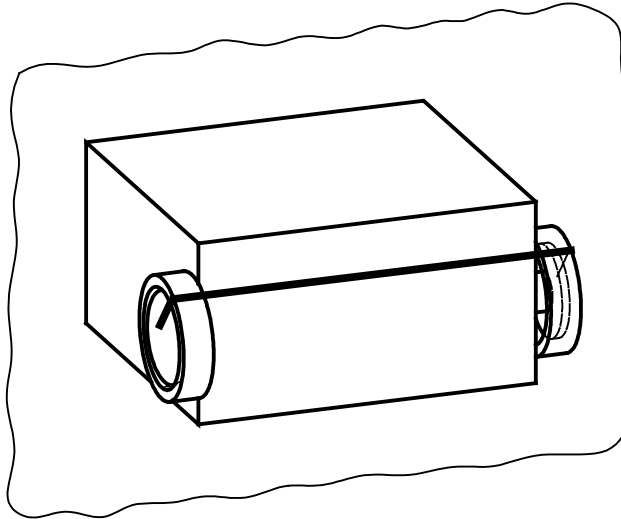

Figure A.3 — Separation by collars and by orientation

### A.3 Prevention of defeat using hand and elbow of the same arm (see 8.3)

A.3.1 Separation of the control actuating devices by a distance equal to or more than 550 mm (see Figure A.4).

Dimensions in millimetres

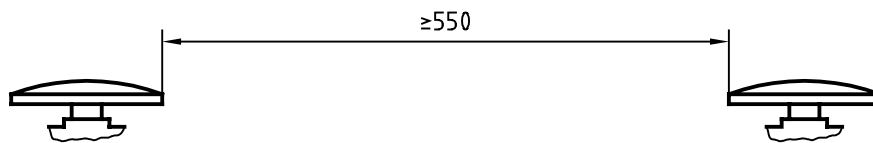
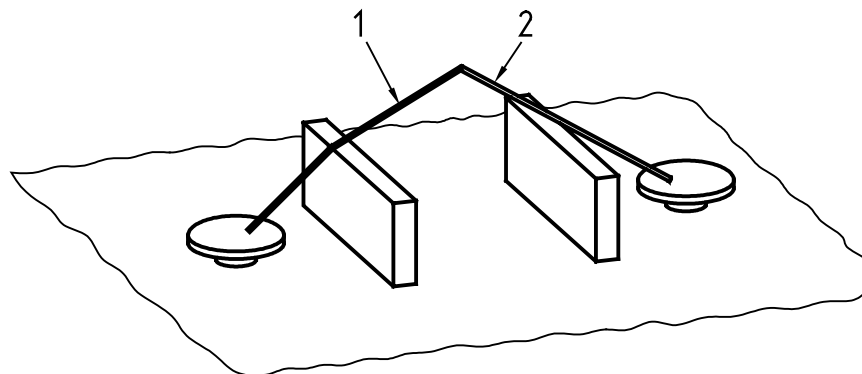

Figure A.4 — Separation by distance

A.3.2 Separation of the control actuating devices by the provision of one or more shields or an elevated area, designed in such a way that the control actuating devices cannot be touched at the same time with both ends of measurement equipment consisting of a 300 mm rigid bar not exceeding 5 mm in diameter and a 250 mm cord attached to it. The bar represents the forearm and the cord the hand, and the equipment shall be used in all possible operating positions (see Figure A.5).



#### Key

- 1 Cord, 250 mm long
- 2 Bar, 300 mm long

Figure A.5 — Separation by shields

**A.3.3** Separation of control actuating devices by shields which are designed to limit access from the operating side and also from the rear in such a way that the control actuating devices cannot be operated from the operating side with the tip of a test cone representing the elbow (see Figure A.6 for method of use). The dimensions of this test cone shall be in accordance with Figure A.7.

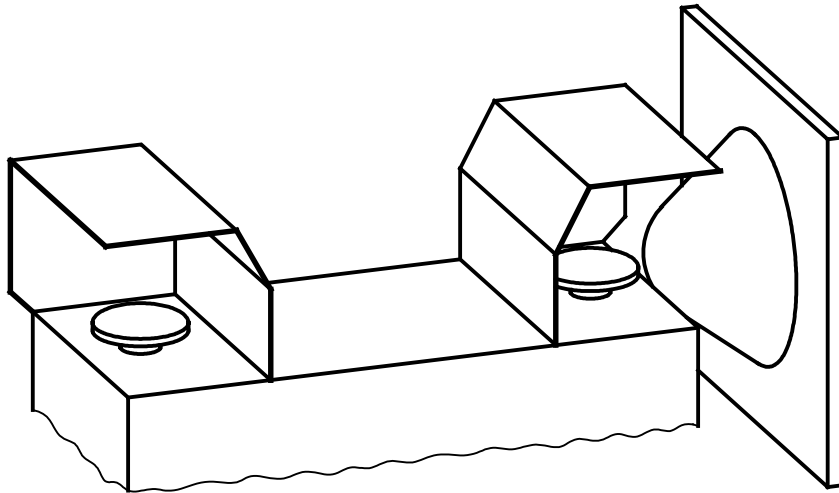

**Figure A.6 — Use of test cone**

Dimensions in millimetres

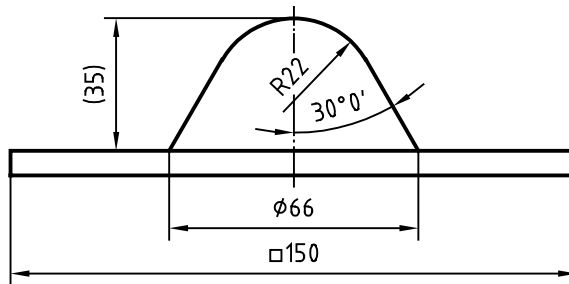
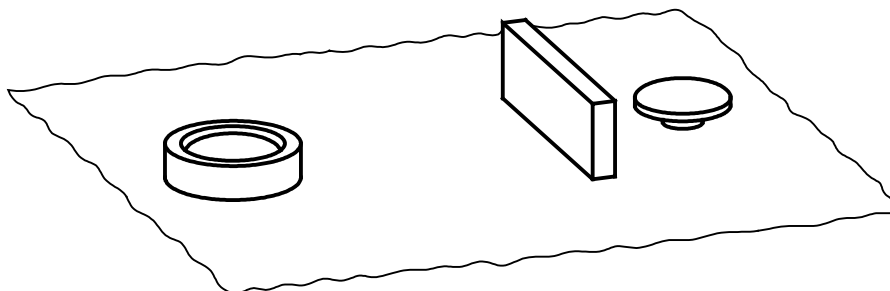

**Figure A.7 — Dimensions of test cone**

**A.3.4** Control actuating devices with different types and/or directions of operation (see Figures A.8 and A.9).

For the configuration shown in Figure A.8, use both the cord and bar (see Figure A.5) and the test cone for the collar (see Figures A.6 and A.7).

For the configuration shown in Figure A.9, use both the cord and bar (see Figure A.5) and the test cone for the collar and for the shield (see Figures A.6 and A.7).



**Figure A.8 — Separation by collar and by shield**



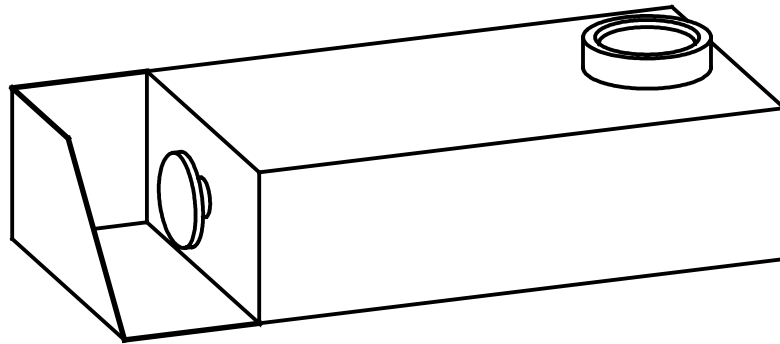

Figure A.9 — Separation by collar, by shield and by orientation

#### A.4 Prevention of defeat using the forearm(s) or elbow(s) (see 8.4)

Shields designed in such a way that the control actuating devices cannot be operated by the forearms and/or the elbows (see Figure A.10).

For the configuration shown in Figure A.10, use the test cone (see Figures A.6 and A.7).

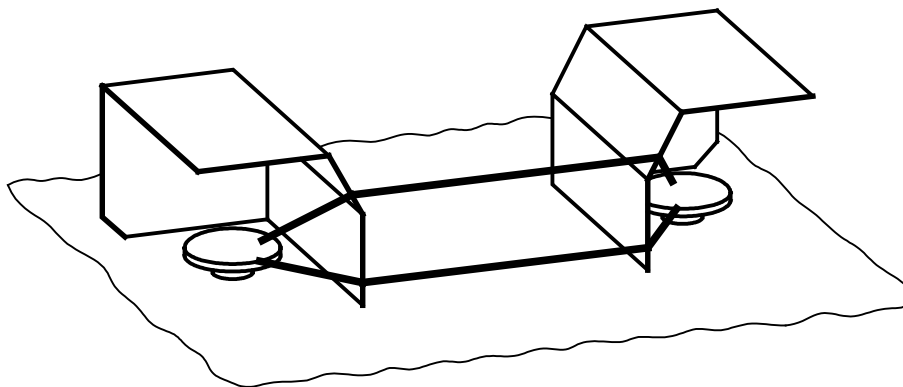

Figure A.10 — Separation by shields

#### A.5 Prevention of defeat using the hand and other parts of the body (see 8.5)

**A.5.1** Arrangement of the control actuating devices on a horizontal or nearly horizontal surface at least 1 100 mm above the floor or level of access (see Figure A.11).

Dimensions in millimetres

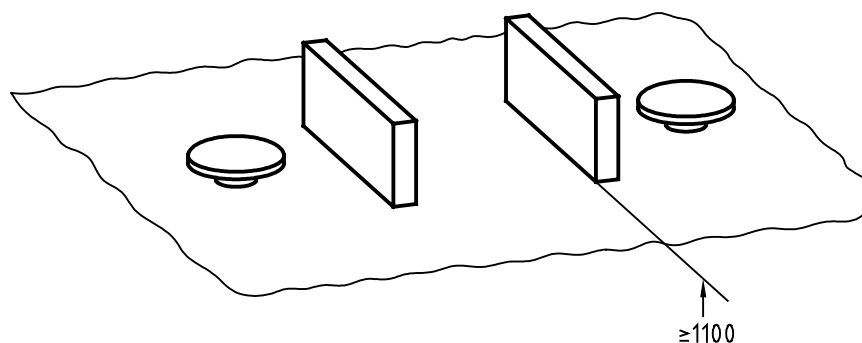
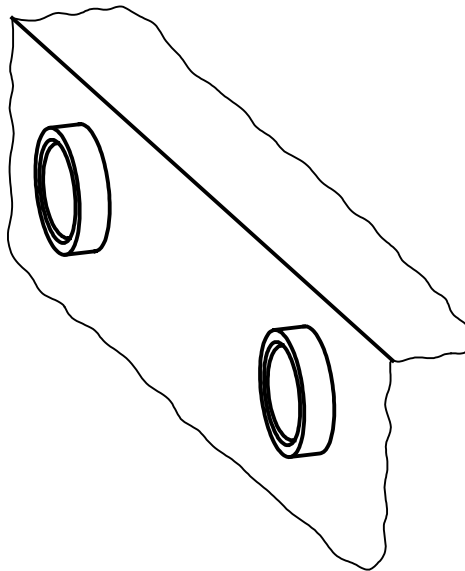

Figure A.11 — Prevention of defeat by position

**A.5.2** Arrangement of the control actuating devices on a vertical or nearly vertical surface with protective collar(s) around the control actuating devices and/or with shield(s) (see e.g. Figures A.9 and A.12).

For the configuration shown in Figure A.12, use both the cord and bar (see Figure A.5) and the test cone for the collar (see Figures A.6 and A.7).



**Figure A.12 — Separation by collars and by position**

**A.5.3** Covers and/or shields (see Figure A.10).

## Annex B (informative)

### Use of categories (in accordance with ISO 13849-1) in types of two-hand control device

Category	Summary of requirements (see ISO 13849-1:1999, clause 6)	Types of two-hand control device
B	Safety-related parts of control systems and/or their protective equipment, as well as their components, shall be designed, constructed, selected, assembled and combined in accordance with relevant standards so that they can withstand the expected influences.	—
1	The requirements of B shall apply. Well-trying components and well-trying safety principles shall be used.	I and IIIA
2	The requirements of B and the use of well-trying safety principles shall apply. The safety function shall be checked at suitable intervals by the machine control system.	—
3	The requirements of B and the use of well-trying safety principles shall apply. Safety-related parts shall be designed so that: <ul style="list-style-type: none"> <li>— a single fault in any of these parts does not lead to the loss of the safety function;</li> <li>— whenever reasonably practicable, the single fault is detected.</li> </ul>	II and IIIB
4	The requirements of B and the use of well-trying safety principles shall apply. Safety-related parts shall be designed so that: <ul style="list-style-type: none"> <li>— a single fault in any of these parts does not lead to the loss of the safety function;</li> <li>— the single fault is detected at or before the next demand upon the safety function (if this is not possible, then an accumulation of faults shall not lead to the loss of the safety function).</li> </ul>	IIIC

**Annex C**  
(informative)

**Relationship between International Standards referenced in clause 2  
and corresponding European Standards**

International Standard	European Standard
ISO/TR 12100-1:1992	EN 292-1:1991 <sup>a</sup>
ISO/TR 12100-2:1992	EN 292-2:1991 <sup>a</sup>
ISO 13849-1:1999	EN 954-1:1996 <sup>a</sup>
ISO 13855:2002	EN 999:1998 <sup>a</sup>
ISO 14121:1999	EN 1050:1996 <sup>a</sup>
IEC 60204-1:1997	EN 60204-1:1997 <sup>a</sup>
<sup>a</sup> Harmonized standard in the sense of the Machinery Directive of the European Union.	

## Bibliography

- [1] IEC 61508, *Functional safety of electrical/electronic/programmable electronic safety-related systems — Part 1: General requirements*
- [2] HSE Guidelines — Programmable Electronic Systems in Safety Related Applications — Part 1 (ISBN 0 11 883913 6) and Part 2 (ISBN 0 11 883906 3)
- [3] Grundsätze für Rechner in Systemen mit Sicherheitsaufgaben (DIN V VDE 0801, Jan. 1990)
- [4] Personal Safety in Microprocessor Control Systems (ECR 184 and 185, Elektronikcentralen, Denmark)

---

---

**ICS 13.110**

Price based on 23 pages

© ISO 2002 – All rights reserved