**Aerospace — Wire, aluminium alloy and
copper-clad aluminium conductors —
General performance requirements**

*Aéronautique et espace — Conducteurs en alliage d'aluminium chemisé
cuivre pour câbles électriques — Exigences générales de performance*



Reference number
ISO 13832:2013(E)

© ISO 2013



COPYRIGHT PROTECTED DOCUMENT

© ISO 2013

All rights reserved. Unless otherwise specified, no part of this publication may be reproduced or utilized otherwise in any form or by any means, electronic or mechanical, including photocopying, or posting on the internet or an intranet, without prior written permission. Permission can be requested from either ISO at the address below or ISO's member body in the country of the requester.

ISO copyright office
Case postale 56 • CH-1211 Geneva 20
Tel. + 41 22 749 01 11
Fax + 41 22 749 09 47
E-mail copyright@iso.org
Web www.iso.org

Published in Switzerland

Contents

	Page
Foreword	iv
Introduction	v
1 Scope	1
2 Normative references	1
3 Terms and definitions	1
4 Characteristics	2
4.1 General	2
4.2 Conductor materials	2
4.3 Material and metal plating for individual strands and code	2
4.4 Electrical and mechanical characteristics	2
4.5 Construction of conductors	3
5 Tests and requirements	3
5.1 Tensile strength and elongation	3
5.2 Mass per unit length	3
5.3 Resistance	4
5.4 Strand-plating continuity	4
5.5 Strand-plating adherence	4
5.6 Strand-plating thickness	4
6 Packaging and labelling	5
6.1 Packaging	5
6.2 Designation and labelling	5
Bibliography	11

Foreword

ISO (the International Organization for Standardization) is a worldwide federation of national standards bodies (ISO member bodies). The work of preparing International Standards is normally carried out through ISO technical committees. Each member body interested in a subject for which a technical committee has been established has the right to be represented on that committee. International organizations, governmental and non-governmental, in liaison with ISO, also take part in the work. ISO collaborates closely with the International Electrotechnical Commission (IEC) on all matters of electrotechnical standardization.

The procedures used to develop this document and those intended for its further maintenance are described in the ISO/IEC Directives, Part 1. In particular the different approval criteria needed for the different types of ISO documents should be noted. This document was drafted in accordance with the editorial rules of the ISO/IEC Directives, Part 2. www.iso.org/directives

Attention is drawn to the possibility that some of the elements of this document may be the subject of patent rights. ISO shall not be held responsible for identifying any or all such patent rights. Details of any patent rights identified during the development of the document will be in the Introduction and/or on the ISO list of patent declarations received. www.iso.org/patents

Any trade name used in this document is information given for the convenience of users and does not constitute an endorsement.

The committee responsible for this document is ISO/TC 20, *Aircraft and space vehicles*, Subcommittee SC 1, *Aerospace electrical requirements*.

Introduction

This International Standard is the general performance requirements of the wires with aluminium and copper-clad aluminium conductors for aerospace.

The need for International Standardization in the Aerospace industry cannot be overemphasized. Multinational projects abound in the construction industry and all major airlines use equipment produced in different continents. The mixture of specifications and standards combine to increase the chances of maintenance errors, no more so than in the interconnection system. Power plant manufacturers in France may use conductors and terminations manufactured in Europe mating at the firewall with terminations and conductors manufactured in North America. This can result in different contacts, crimp tools and settings, and insulating stripping tools being required to work on mating connectors. The same would apply to many types of equipment.

The requirement for close or “clipped” tolerance, lightweight conductors can provide the opportunity to address many of these problems by overcoming the long-standing issue of AWG versus metric sizes.

This International Standard introduces a list of aluminium-based lightweight conductors for aerospace cables. This list supplements the existing list of standard metric conductors which has not received worldwide acceptance. The list is derived from EN 3719, prEN 4651 and MIL-W-7072(MS25191).

The constructions presented are those which are considered to be standards within the emerging rules governing aircraft cables, e.g. seven strands minimum, copper-clad aluminium for size 22 and smaller. However, it does take advantage of the lightest weight for each size. The resultant standard is therefore a mixture of conductors with metric and imperial origins which gives the greatest advantage to constructors and users for the future.

This International Standard:

- obeys existing rules regarding conductors for aircraft;
- gives the lightest weight for each size/rating currently used;
- standardizes the conductor cross-sectional area throughout the world aerospace industry;
- enables the standardization of terminations and the crimp tools used to produce the joints;
- reduces the number of insulation stripping tools required to service aircraft;
- enables the world industry to concentrate its efforts on improving interconnection technology knowing that a world market exists;
- enables regulatory authorities (CAA, FAA, JAA, etc.) to make rules regarding the interconnection system which applies internationally.

All these will, by reducing complexity, reduce servicing errors and contribute to aircraft safety.

Aerospace — Wire, aluminium alloy and copper-clad aluminium conductors — General performance requirements

1 Scope

This International Standard specifies the dimensions, electrical characteristics and mechanical characteristics of aluminium-based and copper-clad aluminium (CCA) conductors, for lightweight aircraft electrical cables and aerospace applications. It applies to stranded conductors over the nominal cross-sectional area range 0,22 mm² to 107 mm² inclusive.

It is not applicable to conductors for conventional copper-based cables, fire-resistant cables or for thermocouple extension cables. Conductors for copper-based cables are specified in ISO 2635, for fire-resistant cables are specified in ISO 1967 and for thermocouple extension cables are specified in ISO 8056-1.

2 Normative references

The following documents, in whole or in part, are normatively referenced in this document and are indispensable for its application. For dated references, only the edition cited applies. For undated references, the latest edition of the referenced document (including any amendments) applies.

ASTM B 566, *Standard Specification for Copper-Clad Aluminum Wire*

ISO 8815, *Aircraft — Electrical cables and cable harnesses — Vocabulary*

3 Terms and definitions

For the purposes of this document, the terms and definitions given in ISO 8815 and the following apply.

3.1

conductor code

numeric or alphanumeric code which designates conductor size and properties

[SOURCE: ISO 2635:2003, 3.1]

3.2

worldwide wire gauge

WWG

identification system, similar to the American wire gauge (AWG) system from which it has been derived, for an international designation of wire cable sizes

[SOURCE: ISO 2635:2003, 3.2]

3.3

copper-clad aluminium

CCA

wire per ASTM B 566 class 15A which consists of an aluminium core with a continuous cladding of copper thoroughly bonded to the core throughout

Note 1 to entry: See [Figure 2](#).

4 Characteristics

4.1 General

The dimensions, electrical resistance, mechanical properties and mass of the conductors shall conform to the values given in [Table 5](#) for CCA wires and [Table 6](#) for aluminium or aluminium alloy wires. The shapes of conductors stranded in concentric lay, bunch or rope lay are illustrated in [Figure 1](#). The wires shall consist of stranded CCA, aluminium or aluminium alloy strands shown in [Figure 2](#).

4.2 Conductor materials

The conductors in accordance with this standard of nominal cross-sectional area 0,25 mm² (code 002) to 0,40 mm² (code 004) shall be produced from a 1 + 6 strands construction. The central strand is a copper alloy strand or equivalent in ISO 2635, surrounded by six CCA strands (see [Figure 1](#)).

The conductors shall consist of individual CCA strands (see ASTM B 566 class 15A), aluminium strands or aluminium alloy strands with the following composition, for cross-sections of greater than 0,25 mm²:

For aluminium: Annealed aluminium (EC grade 99,5 %). See [Table 1](#).

For copper: ETP (Electrolytic touch pitch) copper purity 99,9 % min.

For aluminium alloy: See [Table 2](#).

The conductors shall be manufactured from unused materials that have been exposed only to processes essential to their manufacture and application.

4.3 Material and metal plating for individual strands and code

The individual strands may be:

- uncoated CCA (code A);
- CCA with tin plating (code B);
- CCA with silver plating (code C);
- CCA with nickel plating (code D);
- pure aluminium (code E);
- aluminium alloy with nickel plating (code F)

Plating thicknesses shall be at least 1,0 µm for code C and according to [Table 3](#) for code D.

4.4 Electrical and mechanical characteristics

The maximum resistivity at 20 °C shall be $2,78 \times 10^{-8} \Omega \cdot m$ for CCA and $3,0 \times 10^{-8} \Omega \cdot m$ for aluminium or aluminium alloy.

The elongation at rupture on the complete conductor taken from the finished wire shall be $\geq 6 \%$.

The tensile strength of the complete conductor taken from the finished wire shall be at least 138 MPa (138 N/mm²) for CCA and 105 MPa (105 N/mm²) for aluminium or aluminium alloy.

The elastic limit (at 0,2 % wire elongation) of the complete conductor taken from the finished wire shall be at least 90 MPa (90 N/mm²) for CCA.

4.5 Construction of conductors

4.5.1 Lay length

For CCA conductor up to 5 mm² cross-section inclusive (code 050), concentric conductors are used. The length of lay of the strands of a concentric conductor, checked over the outside layer of a test piece 1 m long, shall be between eight times and 16 times the maximum diameter of this conductor.

For CCA conductor for sectional areas between 9 mm² (code 140) and 107 mm²(code X70), aluminium or aluminium alloy conductor for sectional areas between 5 mm²(code 050) and 107 mm²(code X70), the conductor comprises concentric or bunched conductors twisted together. The length of lay of the strands for the basic concentric or bunched conductors shall not exceed 30 times the diameter of the concentric or bunched conductor in question.

The lay for concentric (or bunched) conductors, measured over the outer layer of the conductor, shall be between eight times and 16 times the maximum conductor diameter.

In all cases the lay of the outer layer shall be left-hand.

4.5.2 Joints

The conductors shall be free from any joints. Each strand comprising the conductors may, however, include soldered or brazed or butt joints.

The distance between two joints in individual strands shall exceed 3 m, measured between different strands.

4.5.3 Compaction

Compaction of the conductor, causing deformation of the strands with damage to the plating, is not permitted.

5 Tests and requirements

5.1 Tensile strength and elongation

5.1.1 Method

Use a tensile tester capable of 1 % accuracy, with jaw separation rates of 200 mm/min to 300 mm/min (copper) and 40 mm/min to 60 mm/min (copper alloy). Test the whole conductor. The initial jaw separation shall be 245 mm to 255 mm.

5.1.2 Requirement

Tensile strength and elongation at break of the conductor prior to insulation shall be as given in [Table 5](#) or [Table 6](#), based on an average of three tests.

5.2 Mass per unit length

Weigh at least 1 m of conductor. The mass per unit length for each size shall be as given in [Table 5](#) or [Table 6](#).

5.3 Resistance

5.3.1 Method

Measure the electrical resistance of the conductor (in ohms) and correct to 20 °C using the following formula:

$$R_T = R_{20} [1 + 0,004 0(T - 20)] \quad (1)$$

where

T is the temperature, in degree Celsius, of the conductor under test;

R_T is the resistance of the conductor at temperature T ;

R_{20} is the resistance at 20 °C.

5.3.2 Requirement

The values calculated shall not exceed those given in [Table 5](#) or [Table 6](#).

5.4 Strand-plating continuity

5.4.1 Method

Take three strands no less than 150 mm in length from a conductor previously straightened by hand.

Degrease the strands without causing damage then wipe, using a clean dry cloth. Ensure that any strands cleaned in this manner are not touched by hand. Immerse the strands for 30 s in a solution of sodium polysulfide of density 1,142 g/cm³ at 20 °C, then wash carefully in distilled water. In addition immerse silver-plated strands for 15 s in a hydrochloric acid solution of density 1,088 g/cm³ at 20 °C and wash carefully in distilled water. Examine the strands with the naked eye.

5.4.2 Requirement

No adherent or distinct black spots shall be observed. Any blackening occurring less than 15 mm from each end shall be disregarded.

5.5 Strand-plating adherence

5.5.1 Method

Take three strands not less than 150 mm in length from a conductor previously straightened by hand. Wind each strand around itself, using half the specimen length as a mandrel so as to form three adjacent turns.

For platings over copper-clad aluminium strands, examine the strands without any magnification.

5.5.2 Requirement

The plating shall not exhibit any detachment or cracks.

5.6 Strand-plating thickness

When measured by any approved method, the thickness shall be 1,0 µm minimum for code C and F and shall be in accordance with [Table 3](#) for code D.

6 Packaging and labelling

6.1 Packaging

Conductors conforming to this International Standard shall be delivered by reels, spools or in coils and shall be protected against damage and the ingress of moisture.

6.2 Designation and labelling

Unless otherwise specified in ordering data, each reel, bobbin or coil shall have firmly attached to it a label bearing the following details:

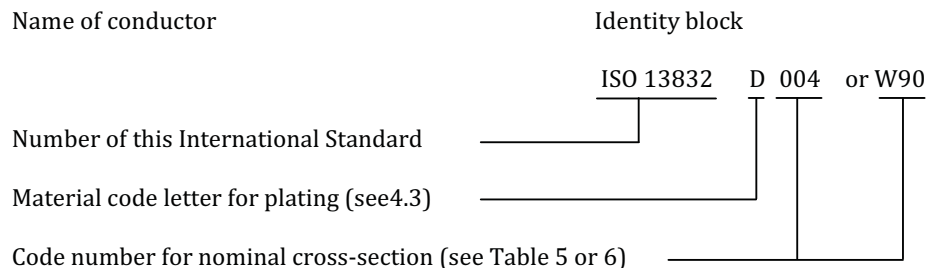

Copyright International Organization for Standardization - All rights reserved

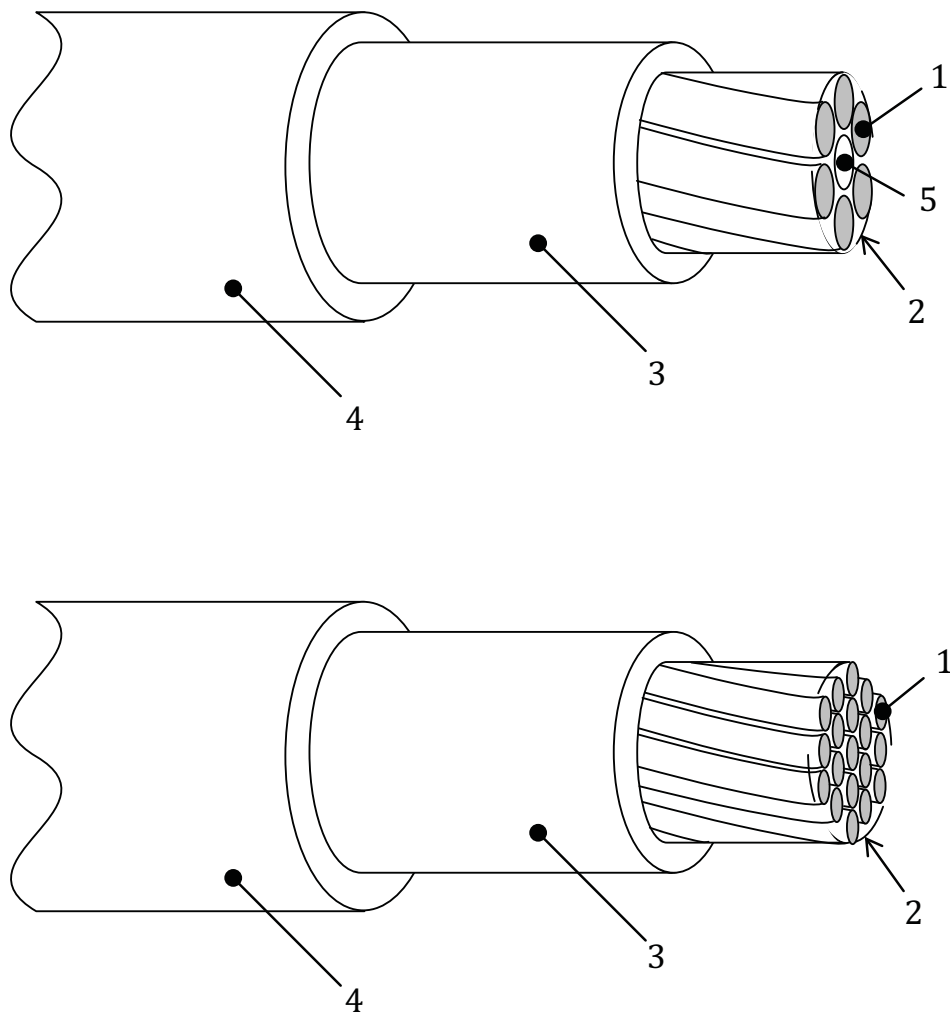

Key

- 1 individual strand
- 2 conductors
- 3 insulation (which shall be specified in standards for hook-up wires)
- 4 sheath or braid (which shall be optionally specified in standards for hook-up wires and cables)
- 5 central strand

Figure 1 — Construction of CCA, aluminium and aluminium alloy conductor

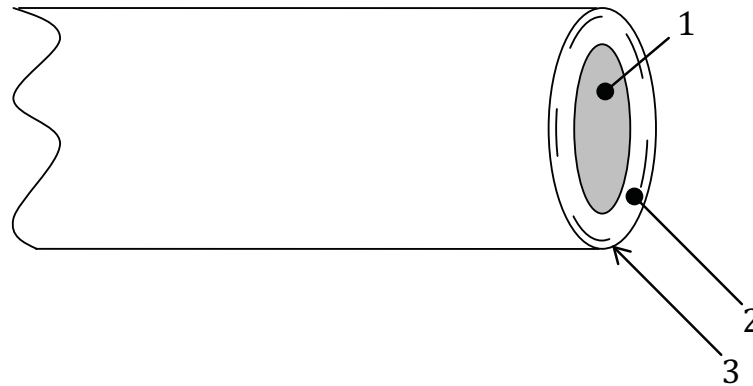

Key

- 1 core
- 2 cladding (CCA only)
- 3 metal plating (optional for CCA only)

Figure 2 — Construction of CCA, aluminium and aluminium alloy strand

Table 1 — Material composition for aluminium conductors

%	Si	Fe	Al
min.	-	-	99,5
max.	0,10	0,40	-

Table 2 — Material composition for aluminium alloy conductors

%	Si	Fe	Cu	Mn	Mg	Cr	Zn	Ga	Ti+V	B	Others		Al
											singly	together	
min.	-	0,50	-	-	0,08	-	-	-	-	-	-	-	99,1
max.	0,30	0,80	0,035	0,01	0,25	0,01	-	-	0,03	0,02	0,03	0,10	-

Table 3 — Characteristics of plating for code D

Dimensions in millimetres

Consistency		Nominal diameter of strands ∅	Thickness of plating µm		WWG
prEN 4651:2008	ABS 0957		min.	max.	
ok	Define min. only	0,20	1,3	2,3	24, 20
ok	Define min. only	0,25	1,3	2,3	22, 18, 14
ok	n/a	0,275	1,3	2,4	8
ok	Define min. only	0,30	1,3	2,6	16, 8
ok	Define min. only	0,32	1,3	2,6	12, 10
ok	Define min. only	0,51	1,3	3,5	6, 4, 3, 2, 1, 0, 00, 000, 0000

Table 4 — Nominal diameter of individual strands

Dimensions in millimetres

Nominal diameter ∅	WWG
0,20	32
0,25	30
0,275	29
0,30	–
0,32	28
0,51	24
NOTE It is optional to apply the diameters outside this table.	

.....

Table 5 — Stranded conductor characteristics for CCA

Code	Nominal cross-section mm ²	Number of strands	Nominal diameter of strands ^c ∅ mm	Diameter of conductor ∅ mm		Resistance at 20°C ^{a b} Ω/km max.	Mass per unit length ^b kg/km max.	WWG	Number of missing single strands
				min.	max.				
002	0,25	1 + 6	0,20	0,56	0,58	145,00	1,10	24	0
004	0,40	1 + 6	0,25	0,71	0,73	90,20	1,70	22	0
006	0,60	19	0,20	0,94	0,97	49,60	2,50	20	0
010	1,00	19	0,25	1,19	1,22	33,20	3,85	18	0
012	1,20	19	0,30	1,41	1,45	23,00	5,35	16	0
020	2,00	37	0,25	1,69	1,73	15,50	8,35	14	0
W20	2,00	37	0,25	1,69	1,73	16,30	8,35	14	0
030	3,00	37	0,32	2,13	2,18	10,90	12,50	12	0
050	5,00	61	0,32	2,73	2,77	5,80	22,50	10	0
W50	5,00	61	0,32	2,73	2,77	6,10	22,50	10	0
090	9,00	7 × 19	0,30	3,55	3,85	3,80	35,50	8	0
W90	9,00	7 × 19	0,275	3,55	3,85	3,80	35,50	8	0
140	14,00	7 × 10	0,51	4,80	5,20	2,30	55,50	6	0
220	22,00	7 × 15	0,51	5,90	6,30	1,50	92,00	4	0
280	28,00	7 × 19	0,51	6,50	7,10	1,18	113,00	3	0
340	34,00	7 × 24	0,51	7,40	8,00	0,94	143,00	2	2
420	42,00	7 × 30	0,51	8,30	8,90	0,75	179,00	1	2
530	53,00	19 × 14	0,51	9,70	10,30	0,60	226,00	0	3
680	68,00	19 × 18	0,51	11,10	11,70	0,43	291,00	00	3
850	85,00	19 × 22	0,51	12,40	13,00	0,36	355,00	000	4
X70	107,00	27 × 20 19 × 28	0,51	14,10	14,80	0,29	452,00	0000	5

NOTE Conductors shall have a minimum of 7 strands. Basically stranded conductors shall be concentric.

^a For other temperatures this may be calculated using the formula shown in EN 3475-301.

^b Not taking into consideration metal plating, assuming that their effect is minimal.

^c Nominal diameters of strands are given for information only.

Table 6 — Stranded conductor characteristics for aluminium or aluminium alloy

Code	Nominal cross-section mm ²	Number of strands	Nominal diameter of strands ^c ∅ mm	Diameter of conductor ∅ mm		Resistance at 20°C ^{a b} Ω/km max.	Mass per unit length ^b kg/km max.	WWG	Number of missing single strands
				min.	max.				
050	5,00	27	0,51	2,70	3,10	5,80	15,4	10	0
090	9,00	41	0,51	3,50	3,90	3,80	25,4	8	0
140	14,00	7 × 10	0,51	4,80	5,20	2,30	45,00	6	0
220	22,00	7 × 15	0,51	5,90	6,30	1,50	67,60	4	0
280	28,00	7 × 19	0,51	6,50	7,10	1,18	77,00	3	0
W80	28,00	7 × 19	0,51	6,50	7,10	1,18	85,50	3	0
340	34,00	7 × 24	0,51	7,40	8,00	0,94	108,10	2	2
420	42,00	7 × 30	0,51	8,30	8,90	0,75	135,30	1	2
530	53,00	19 × 14	0,51	9,70	10,30	0,60	171,30	0	3
680	68,00	19 × 18	0,51	11,10	11,70	0,43	220,30	00	3
850	85,00	19 × 22	0,51	12,40	13,00	0,36	269,20	000	4
X70	107,00	27 × 20	0,51	14,10	14,80	0,29	347,50	0000	5
		19 × 28	0,51						

NOTE Conductors shall have a minimum of 7 strands. Basically stranded conductors shall be concentric.

^a For other temperatures this may be calculated using the formula shown in EN 3475-301.

^b Not taking into consideration metal plating, assuming that their effect is minimal.

^c Nominal diameters of strands are given for information only.

Bibliography

- [1] NEMA WC 67, *Standard for uninsulated conductors used in electrical and electronic applications*
- [2] EN 3719, *Aerospace series — Aluminium or aluminium alloy conductors for electrical cables — Product standard*
- [3] prEN 4651, *Aerospace series — Copper-clad aluminium alloy conductors for electrical cables — Product standard*
- [4] EN 3475, *Aerospace series — Cable, electrical, aircraft use — Test methods*
- [5] MIL-W-7072, *Military specification — Wire, electric, 600 volts, aluminum aircraft general specification for* (cancelled without replacement)
- [6] ISO 2635, *Aircraft — Conductors for general purpose aircraft electrical cables and aerospace applications — Dimensions and characteristics*
- [7] ISO 1967, *Aircraft — Fire-resisting electrical cables — Dimensions, conductor resistance and mass*
- [8] ISO 8056-1, *Aircraft — Nickel-chromium and nickel-aluminium thermocouple extension cables — Part 1: Conductors — General requirements and tests*

ICS 49.060

Price based on 11 pages