

First edition
2012-07-01

**Ships and marine technology — Ship's
mooring and towing fittings — Recessed
bitts (Steel plate type)**

*Navires et technologie maritime — Corps-morts et ferrures de remorquage
de navires — Bittes d'amarrage encastrées (type plaques d'acier)*



Reference number
ISO 13798:2012(E)

© ISO 2012



COPYRIGHT PROTECTED DOCUMENT

© ISO 2012

All rights reserved. Unless otherwise specified, no part of this publication may be reproduced or utilized in any form or by any means, electronic or mechanical, including photocopying and microfilm, without permission in writing from either ISO at the address below or ISO's member body in the country of the requester.

ISO copyright office
Case postale 56 • CH-1211 Geneva 20
Tel. + 41 22 749 01 11
Fax + 41 22 749 09 47
E-mail copyright@iso.org
Web www.iso.org

Published in Switzerland

Contents	Page
Foreword	iv
Introduction	v
1 Scope	1
2 Normative references	1
3 Terms and definitions	1
4 Classification	1
4.1 Type	1
4.2 Nominal sizes	1
5 Dimensions	1
6 Materials	1
7 Construction	2
8 Manufacturing and inspection	2
9 Marking	2
Annex A (informative) Basis for strength assessment of recessed bits (Steel plate type)	4
Bibliography	6

Foreword

ISO (the International Organization for Standardization) is a worldwide federation of national standards bodies (ISO member bodies). The work of preparing International Standards is normally carried out through ISO technical committees. Each member body interested in a subject for which a technical committee has been established has the right to be represented on that committee. International organizations, governmental and non-governmental, in liaison with ISO, also take part in the work. ISO collaborates closely with the International Electrotechnical Commission (IEC) on all matters of electrotechnical standardization.

International Standards are drafted in accordance with the rules given in the ISO/IEC Directives, Part 2.

The main task of technical committees is to prepare International Standards. Draft International Standards adopted by the technical committees are circulated to the member bodies for voting. Publication as an International Standard requires approval by at least 75 % of the member bodies casting a vote.

Attention is drawn to the possibility that some of the elements of this document may be the subject of patent rights. ISO shall not be held responsible for identifying any or all such patent rights.

ISO 13798 was prepared by Technical Committee ISO/TC 8, *Ships and marine technology*, Subcommittee SC 4, *Outfitting and deck machinery*.

Introduction

The recessed bitt is a type of ship's towing fitting installed on the side shell of the ship.

The recessed bitts are normally provided to easily attach the towing lines where the height of the mooring deck is too high.



Ships and marine technology — Ship's mooring and towing fittings — Recessed bits (Steel plate type)

1 Scope

This International Standard specifies the design, size and technical requirements for steel plate type recessed bits to meet normal towing requirements.

2 Normative references

The following referenced documents are indispensable for the application of this document. For dated references, only the edition cited applies. For undated references, the latest edition of the referenced document (including any amendments) applies.

IMO Circular MSC/Circ.1175, *Guidance on shipboard towing and mooring equipment*

3 Terms and definitions

For the purposes of this document, the following terms and definitions apply.

3.1

safe working load

SWL

maximum load in kN on the rope that should normally be applied in service conditions.

4 Classification

4.1 Type

Depending on the manufacturing method, recessed bits shall be classified as the following two types:

- Type A – manufactured by steel pipes;
- Type B – manufactured by steel plates.

4.2 Nominal sizes

The nominal sizes, D_n , of recessed bits are denoted by reference to the outside diameter of the main post in millimetres, in terms of the nearest number drawn from a basic series of preferred numbers. For the recessed bits having the same post diameter, the alphabetical character is followed by the nominal size for the different SWL.

The nominal sizes are: 200, 250, 400A and 400B.

5 Dimensions

Recessed bits have dimensions and particulars in accordance with Table 1 and Figure 1.

6 Materials

The materials of the following components shall be used for manufacturing the recessed bits:

- Plates: weldable steel plates having a yield point of not less than 235 N/mm².

- Tubes: weldable steel tubes having a yield point of not less than 215 N/mm² or equivalent.

7 Construction

- 7.1 The posts of the recessed bitts shall be constructed from steel tubes or formed from plate.
- 7.2 The recess boxes for the installation of the recessed bitt shall be designed with enough space for easy connection of the towing rope. The recess boxes shall be designed to prevent the chafing and damage of the towing rope as much as possible, and to have enough strength as a part of hull construction.

8 Manufacturing and inspection

- 8.1 All surfaces of the recessed bitts, including welding, shall be free from any visible flaws or imperfections.
- 8.2 All surfaces in contact with the ropes shall be free from surface roughness or irregularities likely to cause damage to the ropes by abrasion.
- 8.3 The recessed bitts shall be coated externally with an anti-corrosion protective finish.

9 Marking

- 9.1 The safe working load (SWL) intended for the use of the recessed bitts shall be noted in the towing and mooring plan available on board for the guidance of the shipmaster, as specified in MSC/Circ.1175.
- 9.2 The actual SWL on board shall be determined by considering the reinforcement around the recess box, and it shall be marked on the towing and mooring plan. The actual SWL shall not be over the SWL indicated in this International Standard.
- 9.3 The recessed bitts shall be clearly marked with their SWL by weld bead or equivalent. The SWL shall be expressed in tonnes (letter 't') and be placed so that it is not obscured during operation of the fitting.

EXAMPLE SWL XXX t

Dimensions in millimetres

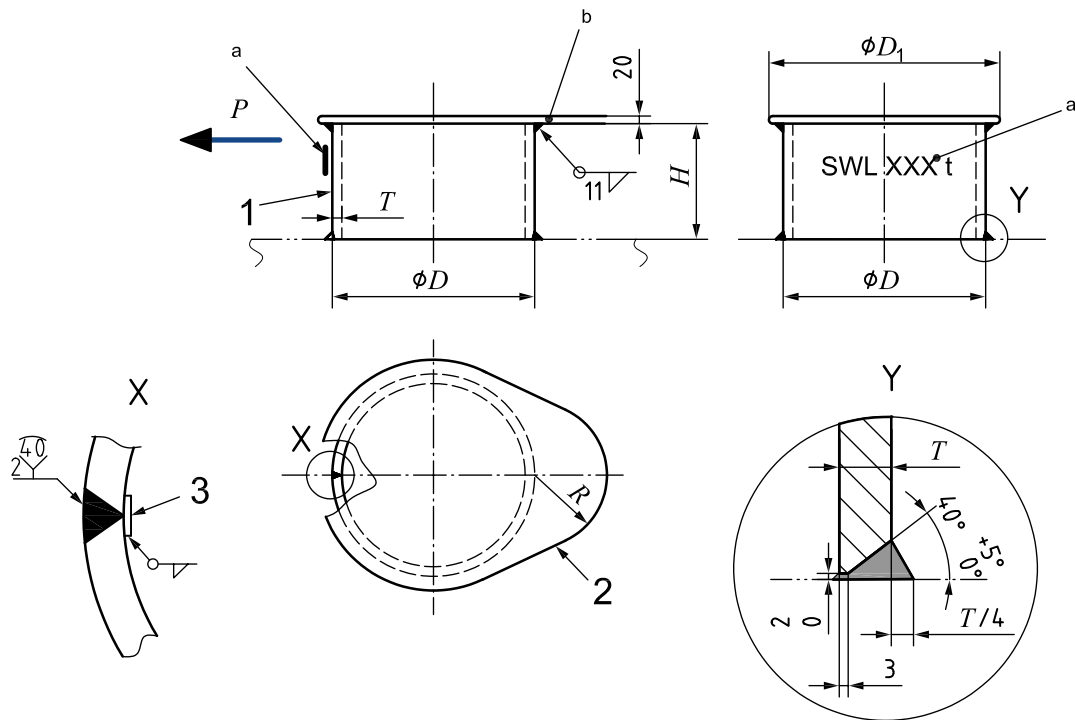

Key

- 1 main post
- 2 top plate
- 3 chill strip
- P* towing force
- a SWL marking.
- b Smooth grinding.

Figure 1 — Recessed bits

Table 1 — Dimensions and SWL of recessed bits

Dimensions in millimetres

Nominal size D_n	Type	D	D_1	R	H	T	SWL ^b		Calculated weight ^c (kg)
							(kN)	(t)	
200	Type A	216,3	250	80	140	10,3	294	30	16,5
	Type B	210,0				10,0			16,1
250	Type A	267,4	305	100	160	12,7	491	50	26,7
	Type B	260,0				12,0			25,7
400A	Type A	406,4	480	140	300	12,7	687	70	69,7
	Type B	410,0				12,0			68,0
400B	Type A	406,4	480	140	330	21,4	1 177	120	99,7
	Type B	410,0				20,0			96,1

^a Welding with chamfering is available based on the same welding volume/strength.

^b The SWL is the maximum applicable rope tension.

The SWLs shown in this table are for reference only. These are based on the loadings as mentioned in Annex A.

^c The calculated weight is for reference only.

Annex A (informative)

Basis for strength assessment of recessed bitts (Steel plate type)

A.1 General

The strength of the recessed bitts was evaluated by simple beam theory calculation and determined based on the following design criteria.

A.2 Loading

A.2.1 The recessed bitts are to be designed to withstand the loads imposed by the towing ropes.

A.2.2 The recessed bitts are to be designed to withstand the following load case.

They are to be designed to withstand the combined load of bending force and shear force produced by P imposed at the upper position.

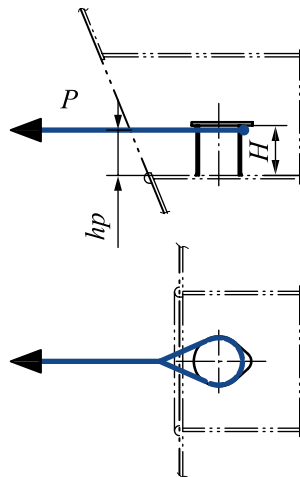

Key

P towing force

d rope diameter (see A.2.3)

hp $H - d/2$

Figure A.1 — Combined loads by towing rope

A.2.3 For the consideration of load point from the towing ropes, the following wire ropes were adopted.

Table A.1 — Diameter of applied ropes for load consideration

Dimensions in millimetres

Nominal size D_n	Rope diameter d
200	30
250	35
400A	40
400B	60

A.3 Load and stress criteria

Under the SWL, the following stress criteria were adopted:

- The bending stress is limited to 85 % of the yield stress of the material.
- The shear stress is limited to 60 % of the yield stress of the material.
- The combined stress is limited to 100 % of the yield stress of the material.

A.4 Wear-down allowances and corrosion additions

A.4.1 Wear-down allowances

For the strength calculation, the wear-down of 2 mm is to be deducted from the gross thickness, where the rope is rubbing the surface.

A.4.2 Corrosion additions

The corrosion margin was already included in the safety factor and 2 mm wear-down allowance.

Bibliography

- [1] IACS UR A2, *Shipboard fittings and supporting hull structures associated with towing and mooring on conventional vessels*
- [2] OCIMF, *Mooring Equipment Guidelines (MEG 3)*
- [3] ISO 2408, *Steel wire ropes for general purposes — Minimum requirements*

ICS 47.020.50

Price based on 6 pages