

---

---

**Thermal performance of buildings —  
Calculation of internal temperatures of  
a room in summer without mechanical  
cooling — General criteria and validation  
procedures**

*Performance thermique des bâtiments — Calcul des températures  
intérieures en été d'un local sans dispositif de refroidissement —  
Critères généraux et procédures de validation*



Reference number  
ISO 13791:2012(E)

© ISO 2012



**COPYRIGHT PROTECTED DOCUMENT**

© ISO 2012

All rights reserved. Unless otherwise specified, no part of this publication may be reproduced or utilized in any form or by any means, electronic or mechanical, including photocopying and microfilm, without permission in writing from either ISO at the address below or ISO's member body in the country of the requester.

ISO copyright office  
Case postale 56 • CH-1211 Geneva 20  
Tel. + 41 22 749 01 11  
Fax + 41 22 749 09 47  
E-mail [copyright@iso.org](mailto:copyright@iso.org)  
Web [www.iso.org](http://www.iso.org)

Published in Switzerland

\*\*\*\*\*

# Contents

Page

Foreword .....	v
Introduction.....	vii
<b>1</b> <b>Scope</b> .....	<b>1</b>
<b>2</b> <b>Normative references</b> .....	<b>1</b>
<b>3</b> <b>Terms, definitions, symbols and units</b> .....	<b>2</b>
<b>3.1</b> <b>Terms and definitions</b> .....	<b>2</b>
<b>3.2</b> <b>Symbols and units</b> .....	<b>3</b>
<b>3.3</b> <b>Subscripts</b> .....	<b>5</b>
<b>4</b> <b>Determination of internal temperatures</b> .....	<b>6</b>
<b>4.1</b> <b>Assumptions</b> .....	<b>6</b>
<b>4.2</b> <b>Evaluation of the relevant temperatures</b> .....	<b>6</b>
<b>4.2.1</b> <b>Internal air temperature</b> .....	<b>6</b>
<b>4.2.2</b> <b>Internal surface temperature</b> .....	<b>7</b>
<b>4.2.3</b> <b>Surface delimiting two solid layers</b> .....	<b>8</b>
<b>4.2.4</b> <b>Surface of an air layer</b> .....	<b>8</b>
<b>4.2.5</b> <b>External surface of a room element</b> .....	<b>9</b>
<b>4.2.6</b> <b>Relevant temperatures for special construction elements</b> .....	<b>9</b>
<b>4.3</b> <b>Room thermal balance</b> .....	<b>10</b>
<b>4.4</b> <b>Boundary conditions</b> .....	<b>11</b>
<b>4.4.1</b> <b>Single room</b> .....	<b>11</b>
<b>4.4.2</b> <b>Similar rooms</b> .....	<b>11</b>
<b>4.4.3</b> <b>Adjacent room with defined value of the air temperature</b> .....	<b>14</b>
<b>4.4.4</b> <b>Floor on ground</b> .....	<b>15</b>
<b>4.4.5</b> <b>Cellar or crawl space</b> .....	<b>15</b>
<b>4.4.6</b> <b>Ceiling below attic</b> .....	<b>15</b>
<b>4.5</b> <b>Terms in the thermal balance equations</b> .....	<b>15</b>
<b>4.5.1</b> <b>Heat conduction through components</b> .....	<b>15</b>
<b>4.5.2</b> <b>Convective heat transfer</b> .....	<b>16</b>
<b>4.5.3</b> <b>Short-wave radiation heat transfers</b> .....	<b>19</b>
<b>4.5.4</b> <b>Long-wave radiation heat transfer</b> .....	<b>23</b>
<b>4.5.5</b> <b>Internal gains</b> .....	<b>25</b>
<b>4.5.6</b> <b>Heat flow due to ventilation</b> .....	<b>26</b>
<b>5</b> <b>Determination of internal humidity</b> .....	<b>27</b>
<b>6</b> <b>Procedure for carrying out calculations</b> .....	<b>27</b>
<b>6.1</b> <b>General</b> .....	<b>27</b>
<b>6.2</b> <b>Design climatic data</b> .....	<b>27</b>
<b>6.2.1</b> <b>General</b> .....	<b>27</b>
<b>6.2.2</b> <b>Long-period design climatic data</b> .....	<b>28</b>
<b>6.2.3</b> <b>Design warm sequence</b> .....	<b>28</b>
<b>6.3</b> <b>Geometrical and thermophysical characteristics of room elements</b> .....	<b>28</b>
<b>6.4</b> <b>Design internal gains</b> .....	<b>28</b>
<b>6.5</b> <b>Design occupant behaviour</b> .....	<b>28</b>
<b>6.6</b> <b>Calculation procedure</b> .....	<b>29</b>
<b>6.6.1</b> <b>General</b> .....	<b>29</b>
<b>6.6.2</b> <b>Definition of the starting conditions</b> .....	<b>29</b>
<b>6.6.3</b> <b>Prediction of the internal temperatures</b> .....	<b>29</b>
<b>7</b> <b>Report of the calculation</b> .....	<b>29</b>

<b>8</b>	<b>Validation procedures</b> .....	<b>30</b>
<b>8.1</b>	<b>Introduction</b> .....	<b>30</b>
<b>8.2</b>	<b>Validation of heat transfer processes</b> .....	<b>30</b>
<b>8.2.1</b>	<b>General</b> .....	<b>30</b>
<b>8.2.2</b>	<b>Heat conduction through opaque elements</b> .....	<b>30</b>
<b>8.2.3</b>	<b>Internal long-wave radiation exchanges</b> .....	<b>32</b>
<b>8.2.4</b>	<b>Sunlit area of a window due to external obstructions</b> .....	<b>34</b>
<b>8.3</b>	<b>Validation procedure for the whole calculation method</b> .....	<b>37</b>
<b>8.3.1</b>	<b>General</b> .....	<b>37</b>
<b>8.3.2</b>	<b>Geometry for the test rooms</b> .....	<b>38</b>
<b>8.3.3</b>	<b>Thermophysical properties of opaque walls</b> .....	<b>39</b>
<b>8.3.4</b>	<b>Properties of glazing</b> .....	<b>39</b>
<b>8.3.5</b>	<b>Solar parameters</b> .....	<b>41</b>
<b>8.3.6</b>	<b>Boundary conditions</b> .....	<b>42</b>
<b>8.3.7</b>	<b>Internal energy sources</b> .....	<b>45</b>
<b>8.3.8</b>	<b>Ventilation</b> .....	<b>46</b>
<b>8.3.9</b>	<b>Descriptions of the validation tests</b> .....	<b>46</b>
<b>Annex A</b>	<b>(informative) Example of solution technique</b> .....	<b>49</b>
<b>Annex B</b>	<b>(informative) Convective heat transfer through ventilated air layer</b> .....	<b>57</b>
<b>Annex C</b>	<b>(informative) Shading due to overhangs and side fins</b> .....	<b>64</b>
<b>Annex D</b>	<b>(informative) Design climatic data in the warm season</b> .....	<b>72</b>
<b>Annex E</b>	<b>(informative) Calculation of the internal long-wave radiation exchanges in buildings</b> .....	<b>73</b>
<b>Annex F</b>	<b>(informative) External radiative long-wave heat transfer coefficients</b> .....	<b>75</b>
<b>Annex G</b>	<b>(informative) Solar factors</b> .....	<b>77</b>
<b>Annex H</b>	<b>(informative) Internal gains</b> .....	<b>79</b>
<b>Annex I</b>	<b>(informative) Air ventilation</b> .....	<b>81</b>
<b>Annex J</b>	<b>(informative) Detailed results of the validation tests considered in the “whole validation model” procedure</b> .....	<b>89</b>
<b>Annex K</b>	<b>(informative) Calculation method for internal humidity without moisture absorption into or desorption from walls and other structures</b> .....	<b>91</b>
<b>Annex L</b>	<b>(informative) Normative references to international publications with their corresponding European publications</b> .....	<b>94</b>
<b>Bibliography</b>	.....	<b>96</b>



## Foreword

ISO (the International Organization for Standardization) is a worldwide federation of national standards bodies (ISO member bodies). The work of preparing International Standards is normally carried out through ISO technical committees. Each member body interested in a subject for which a technical committee has been established has the right to be represented on that committee. International organizations, governmental and non-governmental, in liaison with ISO, also take part in the work. ISO collaborates closely with the International Electrotechnical Commission (IEC) on all matters of electrotechnical standardization.

International Standards are drafted in accordance with the rules given in the ISO/IEC Directives, Part 2.

The main task of technical committees is to prepare International Standards. Draft International Standards adopted by the technical committees are circulated to the member bodies for voting. Publication as an International Standard requires approval by at least 75 % of the member bodies casting a vote.

Attention is drawn to the possibility that some of the elements of this document may be the subject of patent rights. ISO shall not be held responsible for identifying any or all such patent rights.

ISO 13791 was prepared by Technical Committee ISO/TC 163, *Thermal performance and energy use in the built environment*, Subcommittee SC 2, *Calculation methods*.

This second edition cancels and replaces the first edition (ISO 13791:2004), which has been technically revised. The main changes compared to the previous edition are given in the following table:

Clause/subclause	Changes
2	Added ISO 9050, ISO 10292, ISO 15099, ISO 15927-2 and EN 673
3.2	Deleted $q_a$ and $v_m$ and added $m_a$
4.2.1	Amended Equation (1) Deleted $m_{a,i}$ and added the descriptions of $\rho_a$ and $v_{ai}$
4.5.6.1	Replaced $q_a$ by $m_a$
8.3.9.1	Amended the values in Tables 22 and 23
8.3.9.2	Amended the values in Tables 24 and 25
1.2.2	Replaced $m$ by $m_a$ Amended Equation (I.1) and added the descriptions of $n$ and $\Delta p_0$ Amended Equation (I.4) and added the description of $\Delta C_w$ Amended the unit used in Table I.1
1.2.3	Replaced $m$ , $m_w$ and $m_T$ by $m_a$ , $m_{a,w}$ and $m_{a,T}$ , respectively Amended Equations (I.5), (I.6), (I.9), (I.10), (I.11), (I.12), (I.13) and (I.14) Replaced $A$ by $A_T$ in Equation (I.13) Replaced $\Delta c_p$ by $\Delta C_w$ Added the descriptions of Equations (I.8) and (I.10)
1.2.3.3.3	Amended the description 1.2.3.3.3
1.3.2	Replaced $\Delta c_p$ by $\Delta C_w$ Replaced $m_w$ by $m_{a,w}$
1.3.3	Replaced $m_T$ by $m_{a,T}$
Annex J	Amended the values in Tables J.1 and J.2
Annex K	Added as a new annex

## Introduction

This International Standard is intended for use by specialists to develop and/or validate methods for the hourly calculation of the internal temperatures of a single room.

Examples of application of such methods include:

- a) assessing the risk of internal overheating;
- b) optimizing aspects of building design (building thermal mass, solar protection, ventilation rate, etc.) to provide thermal comfort conditions;
- c) assessing whether a building requires mechanical cooling.

Criteria for building performance are not included. They can be considered at national level. This International Standard can also be used as a reference to develop more simplified methods for the above and similar applications.

Copyright International Organization for Standardization



# Thermal performance of buildings — Calculation of internal temperatures of a room in summer without mechanical cooling — General criteria and validation procedures

## 1 Scope

This International Standard specifies the assumptions, boundary conditions, equations and validation tests for a calculation procedure, under transient hourly conditions, of the internal temperatures (air and operative) during warm periods, of a single room without any cooling/heating equipment in operation. No specific numerical techniques are imposed by this International Standard. Validation tests are included in Clause 8. An example of a solution technique is given in Annex A.

This International Standard does not contain sufficient information for defining a procedure able to determine the internal conditions of special zones such as attached sun spaces, atria, indirect passive solar components (trombe walls, solar panels) and zones in which the solar radiation may pass through the room. For such situations different assumptions and more detailed solution models are needed (see Bibliography).

## 2 Normative references

The following referenced documents are indispensable for the application of this document. For dated references, only the edition cited applies. For undated references, the latest edition of the referenced document (including any amendments) applies.

ISO 6946, *Building components and building elements — Thermal resistance and thermal transmittance — Calculation method*

ISO 7345, *Thermal insulation — Physical quantities and definitions*

ISO 9050, *Glass in building — Determination of light transmittance, solar direct transmittance, total solar energy transmittance, ultraviolet transmittance and related glazing factors*

ISO 9251, *Thermal insulation — Heat transfer conditions and properties of materials — Vocabulary*

ISO 9288, *Thermal insulation — Heat transfer by radiation — Physical quantities and definitions*

ISO 9346, *Hygrothermal performance of buildings and building materials — Physical quantities for mass transfer — Vocabulary*

ISO 10077-1, *Thermal performance of windows, doors and shutters — Calculation of thermal transmittance — Part 1: General*

ISO 10077-2, *Thermal performance of windows, doors and shutters — Calculation of thermal transmittance — Part 2: Numerical method for frames*

ISO 10292, *Glass in building — Calculation of steady-state U values (thermal transmittance) of multiple glazing*

ISO 13370, *Thermal performance of buildings — Heat transfer via the ground — Calculation methods*

ISO 15099, *Thermal performance of windows, doors and shading devices — Detailed calculations*

ISO 15927-2, *Hygrothermal performance of buildings — Calculation and presentation of climatic data — Part 2: Hourly data for design cooling load*

EN 410, *Glass in building — Determination of luminous and solar characteristics of glazing*

EN 673, *Glass in building — Determination of thermal transmittance (U value) — Calculation method*

### **3 Terms, definitions, symbols and units**

#### **3.1 Terms and definitions**

For the purposes of this document, the terms and definitions given in ISO 7345, ISO 9251, ISO 9288, ISO 9346 and the following apply.

##### **3.1.1**

##### **internal environment**

closed space delimited from the external environment or adjacent spaces by the building fabric

##### **3.1.2**

##### **room element**

wall, roof, ceiling, floor, door or window that separates the internal environment from the external environment or an adjacent space

##### **3.1.3**

##### **room air**

air of the internal environment

##### **3.1.4**

##### **internal air temperature**

temperature of the room air

##### **3.1.5**

##### **internal surface temperature**

temperature of the internal surface of a building element

##### **3.1.6**

##### **mean radiant temperature**

uniform surface temperature of an enclosure in which an occupant would exchange the same amount of radiant heat as in the actual non-uniform enclosure

##### **3.1.7**

##### **operative temperature**

uniform temperature of an enclosure in which an occupant would exchange the same amount of heat by radiation plus convection as in the actual non-uniform environment

### 3.2 Symbols and units

For the purposes of this document, the following symbols and units apply.

Symbol	Definition	Unit
$A$	area	$m^2$
$A_c$	area of the surface in contact with the air layer	$m^2$
$A_f$	floor area	$m^2$
$A_j$	area of room element $j$	$m^2$
$A_p$	projected area of the considered system	$m^2$
$A_s$	sunlit area	$m^2$
$A_{sh}$	shaded area	$m^2$
$a$	thermal diffusivity	$m^2/s$
$C$	heat capacity	J/K
$c$	specific heat capacity	J/(kg·K)
$c_a$	specific heat capacity of air	J/(kg·K)
$c_d$	coefficient of discharge	—
$c_{me}$	specific heat capacity of the medium	J/(kg·K)
$c_v$	velocity coefficient	—
$d$	thickness	m
$E_r$	ventilation parameter	—
$F$	view factor	—
$F_{sk}$	view factor from the element with the sky	—
$f_d$	solar distribution factor	—
$f_{ic}$	internal convective factor	—
$f_s$	sunlit factor	—
$f_{sa}$	solar to air factor	—
$f_{sl}$	solar loss factor	—
$G_i$	moisture production	kg/s
$G_v$	moisture influx by ventilation	kg/s
$g_s$	heat flow rate per volume	W/m <sup>3</sup>
$g$	acceleration due to gravity	m/s <sup>2</sup>
$H$	height of the element	m
$h$	surface coefficient of heat transfer	W/(m <sup>2</sup> ·K)
$h_a$	convective heat transfer coefficient for ventilated layers	W/(m <sup>2</sup> ·K)
$h_c$	convective heat transfer coefficient of the surface	W/(m <sup>2</sup> ·K)
$h_g$	convective heat transfer coefficient for closed spaces	W/(m <sup>2</sup> ·K)
$h_{lr}$	long-wave radiative heat transfer coefficient	W/(m <sup>2</sup> ·K)

$I$	intensity of solar radiation	W/m <sup>2</sup>
$I_d$	diffuse component of the solar radiation reaching the surface	W/m <sup>2</sup>
$I_D$	direct component of the solar radiation reaching the surface	W/m <sup>2</sup>
$J_{lr,j}$	long-wave radiosity	W/m <sup>2</sup>
$k$	crack coefficient	—
$l$	length	m
$m_a$	mass air flow rate	kg/s
$m_{a,m}$	mass forced air flow rate by mechanical ventilation	kg/s
$m_{a,n}$	mass air flow rate by natural ventilation	kg/s
$m_{a,T}$	mass flow rate due to temperature	kg/s
$m_{a,w}$	mass flow rate due to wind	kg/s
$n$	flow exponent	—
$p$	pressure	Pa
$q$	density of heat flow rate	W/m <sup>2</sup>
$q_c$	density of heat flow rate by convection	W/m <sup>2</sup>
$q_{cd}$	density of heat flow rate by conduction	W/m <sup>2</sup>
$q_{c,i}$	density of heat flow rate by conduction at the internal surface	W/m <sup>2</sup>
$q_{lr}$	density of heat flow rate due to long-wave radiation exchanged with other internal surfaces	W/m <sup>2</sup>
$q_{sk}$	correction for the long-wave radiation exchanges from the wall to the sky	W/m <sup>2</sup>
$q_{sr}$	density of heat flow rate due to the absorbed short-wave radiation	W/m <sup>2</sup>
$R$	thermal resistance	m <sup>2</sup> ·K/W
$T$	thermodynamic temperature	K
$T_e$	temperature of the environment	K
$T_{in}$	temperature of the air entering the air layer	K
$T_{out}$	temperature of the air leaving the layer	K
$t$	time	s
$U$	thermal transmittance	W/(m <sup>2</sup> ·K)
$V$	volume	m <sup>3</sup>
$v$	velocity	m/s
$x,y,z$	co-ordinates	m
$\Lambda$	thermal conductance	W/(m <sup>2</sup> ·K)
$\Phi$	heat flow rate	W
$\Phi_i$	heat flow rate due to internal sources	W
$\Phi_{sa}$	solar to air heat flow rate	W
$\Phi_{sr}$	heat flow rate of solar radiation entering the room	W

$\Phi_v$	heat flow rate by ventilation	W
$\Phi_{va}$	heat flow rate due to the air entering the room through air layers within the elements bounding the room	W
$\alpha$	solar absorptance	—
$\varepsilon$	long-wave emissivity of the surface	
$\theta$	celsius temperature	°C
$\theta_{a,d}$	defined air temperature of the adjacent room	°C
$\theta_{a,e}$	air temperature of the adjacent room	°C
$\theta_{a,i}$	temperature of the internal air	°C
$\theta_v$	temperature of the mechanically supplied air	°C
$\lambda$	thermal conductivity	W/(m·K)
$\mu$	viscosity	kg/(m·s)
$v_i$	humidity by volume of internal air	kg/m <sup>3</sup>
$v_{in}$	humidity by volume of inflowing air	kg/m <sup>3</sup>
$\rho$	solar reflectance	—
$\rho_a$	density of air	kg/m <sup>3</sup>
$\rho_m$	average solar reflection coefficient of room surfaces	—
$\rho_{me}$	density of the medium	kg/m <sup>3</sup>
$\rho_{a,0}$	density of the air at the temperature $T_0$	kg/m <sup>3</sup>
$\sigma$	Stefan-Boltzmann constant	W/(m <sup>2</sup> ·K <sup>4</sup> )

### 3.3 Subscripts

a	air	cd	conduction
b	building	ec	external ceiling
c	convection	ef	external floor
D	direct solar radiation	eq	equivalent
d	diffuse solar radiation	ic	internal ceiling
e	external	if	internal floor
g	ground	il	inlet section
i	internal	lr	long-wave radiation
l	leaving the section	mr	mean radiant
n	normal to surface	op	operative
r	radiation	sa	solar to air
s	surface	sk	sky
sl	solar loss	t	time
sr	short-wave radiation	v	ventilation
va	ventilation through air cavity		

## 4 Determination of internal temperatures

### 4.1 Assumptions

The evaluation of the internal temperature of a room involves the solution of a system of equations of the transient heat and mass transfers between the external and internal environment through the opaque and transparent elements bounding the room envelope. The procedures given in this International Standard allow the user to determine the time-dependent temperature of each component, including the internal air. Accepted assumptions for the calculation of the internal temperatures of a single room under transient conditions in absence of any cooling plant are:

- the air temperature is uniform throughout the room;
- the various surfaces of the room elements are isothermal;
- the thermophysical properties of the materials composing the room elements are time-independent;
- the heat conduction through the room elements (excluding to the ground) is assumed to be one-dimensional;
- the heat conduction to the ground through room elements is treated by an equivalent one-dimensional heat flow rate according to ISO 13370;
- the effect of thermal bridges is generally neglected, but if it is considered the heat storage contribution of the thermal bridges is neglected;
- air spaces are treated as air layers bounded by two isothermal and parallel surfaces;
- convective heat transfer coefficients: at the external surface they depend on the wind velocity and direction, at the internal surface they depend on the direction of the heat flow;
- the long-wave radiative heat flow rate at the external surfaces of the room elements is related to a time-independent heat transfer coefficient;
- the external radiant environment (sky excluded) is at the external air temperature (see 4.5.4.1);
- the distribution of solar radiation within the room is time-independent;
- the dimensions of each element are measured inside the room;
- the mean radiant temperature is calculated by weighting the various internal surface temperatures according to the relevant areas;
- the operative temperature is the average between the internal air temperature and the mean surface temperature.

### 4.2 Evaluation of the relevant temperatures

#### 4.2.1 Internal air temperature

The air temperature of a room, at any given time, is obtained by solving Equation (1), where heat flow rates to room air are taken as positive:

$$\sum_{j=1}^N (A q_{c,i})_j + \Phi_v + \Phi_{i,c} + \Phi_{sa} + \Phi_{va} = c_a \rho_a V_{a,i} \frac{\partial \theta_{a,i}}{\partial t} \quad (1)$$

where

- $N$  is the number of internal surfaces delimiting the internal air;
- $A$  is the area of each building element;
- $q_{c,i}$  is the density of the heat flow rate by convection at the internal surface (see 4.5.2.2);
- $\Phi_v$  is the heat flow rate by ventilation (see 4.5.6);
- $\Phi_{l,c}$  is the convective part of heat flow rate due to internal sources (see 4.5.5);
- $\Phi_{sa}$  is the solar to air heat flow rate (see 4.5.3.4);
- $\Phi_{va}$  is the heat flow rate due to the air entering the room through air layers within the elements bounding the room;
- $c_a$  is the specific heat capacity of air;
- $\rho_a$  is the density of the internal air;
- $V_{a,i}$  is the volume of the internal air;
- $\theta_{a,i}$  is the temperature of the internal air;
- $t$  is the time.

NOTE Because of the very small value of the term  $(\rho_a V_{a,i})$  the right-hand side of Equation (1) can be assumed to be zero.

#### 4.2.2 Internal surface temperature

The internal surface temperature at element  $j$  is obtained by solving Equation (2), where heat flow rates to the internal surface, except  $q_{c,j}$ , are taken as positive:

$$q_{lr,j} + q_{sr,j} + q_{c,j} + q_{cd,j} + \frac{\Phi_{l,r}}{\sum_{j=1}^N A_j} = 0 \quad (2)$$

where

- $q_{lr}$  is the density of heat flow rate due to long-wave radiation exchanged with other internal surfaces (see 4.5.4.2);
- $q_{sr}$  is the density of heat flow rate due to the absorbed short-wave radiation (see 4.5.3.2);
- $q_c$  is the density of heat flow rate released to room air by convection (see 4.5.2.2);
- $q_{cd}$  is the density of heat flow rate by conduction (see 4.5.1);
- $\Phi_{l,r}$  is the heat flow rate due to the radiative component of internal gains (see 4.5.5);
- $N$  is the number of surfaces delimiting the internal air;
- $A_j$  is the area of room element  $j$ .

4.2.3 Surface delimiting two solid layers

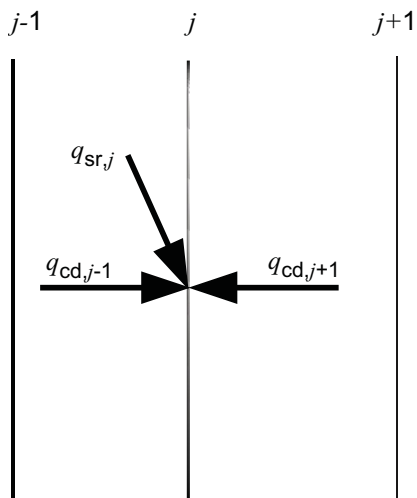

Figure 1 — Surface delimiting two layers

The temperature at surface  $j$  delimiting two layers in an element (Figure 1) is obtained by solving Equation (3):

$$q_{cd,j-1} + q_{cd,j+1} + q_{sr,j} = 0 \tag{3}$$

where

$q_{cd,j-1}$  is the density of heat flow rate by conduction from the  $j-1$  surface (see 4.5.1);

$q_{cd,j+1}$  is the density of heat flow rate by conduction from the  $j+1$  surface (see 4.5.1);

$q_{sr,j}$  is the density of heat flow rate due to the solar radiation absorbed by the surface  $j$ .

4.2.4 Surface of an air layer

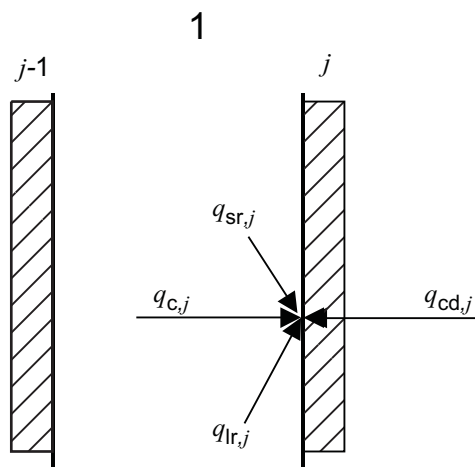

Key

1 air layer

Figure 2 — Surface delimiting an air layer



The temperature at surface  $j$  of an air layer (Figure 2) is obtained by solving Equation (4):

$$q_{c,j} + q_{lr,j} + q_{cd,j} + q_{sr,j} = 0 \quad (4)$$

where

$q_c$  is the density of the total heat flow rate released to the air layer (see 4.5.2);

$q_{lr}$  is the density of the heat flow rate received by long-wave radiation across the air layer (see 4.5.4);

$q_{cd}$  is the density of the heat flow by conduction (see 4.5.1);

$q_{sr}$  is the density of heat flow rate absorbed due to an external source (e.g. solar radiation).

#### 4.2.5 External surface of a room element

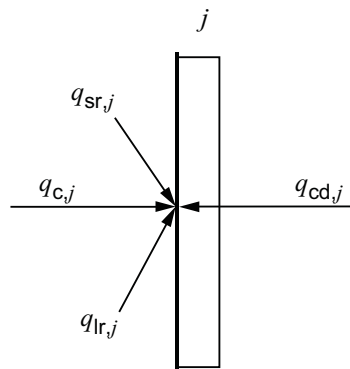

Figure 3 — External surface of an element

The temperature at surface  $j$  of a room element (Figure 3) is obtained by solving Equation (5):

$$q_{lr,j} + q_{sr,j} + q_{c,j} + q_{cd,j} = 0 \quad (5)$$

where

$q_{lr}$  is the density of heat flow rate by long-wave radiation at the surface (see 4.5.4.1);

$q_{sr}$  is the density of heat flow rate due to the short-wave radiation absorbed by the surface (see 4.5.3.1);

$q_c$  is the density of heat flow rate by convection with the air (see 4.5.2.2);

$q_{cd}$  is the density of the conduction heat flow rate (see 4.5.1).

#### 4.2.6 Relevant temperatures for special construction elements

##### 4.2.6.1 Ceiling below an attic

The ceiling, the air space and the roof are considered as a single horizontal element with one-dimensional heat flow. The air space is considered as an air layer, treated in 4.5.2.3 and 4.5.2.4.

#### 4.2.6.2 Floor on ground

The floor and the soil are considered as a single horizontal element with the heat flow treated according to ISO 13370. Boundary conditions are specified in 4.4.4.

#### 4.2.6.3 Floor over cellar

The cellar is treated as an unheated basement according to ISO 13370. The calculation procedure is according to ISO 13370. Boundary conditions are specified in 4.4.5.

#### 4.2.6.4 Floor over crawl space

The floor, the crawl space and the soil are treated as a suspended floor according to ISO 13370. Boundary conditions are specified in 4.4.5.

#### 4.2.6.5 Glazed element

A glazed element is composed of a number of planes (glazing panes and possibly blinds) which are in thermal equilibrium with one another. The evaluation of temperatures of each plane is made using the following assumptions:

- the heat storage effects in the various planes are neglected;
- the heat flow by convection through the air layers between each pane is calculated according to 4.5.2.3 and 4.5.2.4;
- the density of heat flow rate due to the long-wave radiation between the various planes is calculated according to 4.5.4.3;
- the density of heat flow rate due to the short-wave radiation absorbed by each plane is treated as a source term.

### 4.3 Room thermal balance

In each equation of 4.2, the time-dependent heat flow rates shall be expressed in terms of operators which relate the heat flow rate at the internal surface of each element to the temperature at the internal and external surface, and that of the internal air, by using suitable mathematical models of the heat transfer processes. The temperature of the internal air, together with the temperature of the different surfaces, shall be determined by solving the global equation system at each time step considered. A general expression of the equation system is expressed in Equation (6):

$$\begin{pmatrix} \Pi_{1,1} & \Pi_{1,2} & \Pi_{1,N} & \Pi_{1,N+1} \\ \Pi_{2,1} & \Pi_{2,2} & \Pi_{2,N} & \Pi_{2,N+1} \\ \Pi_{N,1} & \Pi_{N,2} & \Pi_{N,N} & \Pi_{N,N+1} \\ \Pi_{N+1,1} & \Pi_{N+1,2} & \Pi_{N+1,N} & \Pi_{N+1,N+1} \end{pmatrix} \cdot \begin{pmatrix} \theta_{is,1} \\ \theta_{is,2} \\ \theta_{is,N} \\ \theta_a \end{pmatrix} = \begin{pmatrix} \Gamma_1 \\ \Gamma_2 \\ \Gamma_N \\ \Gamma_{N+1} \end{pmatrix} \quad (6)$$

where

- $N$  is the number of elements bounding the room corresponding to the internal surfaces delimiting the internal air;
- $\Pi$  are the coefficients of the unknown temperatures ( $\theta$ ) (from 1 to  $N$  relating to the internal surfaces,  $N + 1$  relating to the internal air);
- $\Gamma$  are the coefficients of the known terms (from 1 to  $N$  relating to the internal surfaces,  $N + 1$  relating to the internal air);

$\theta$  are the unknown temperatures (from 1 to  $N$  relating to the internal surfaces,  $N + 1$  relating to the internal air).

The “ $H$ ” and “ $I$ ” terms are obtained by rewriting Equation (1) and Equation (2) in order to separate the unknown parameters [air temperature at the given time  $t$  for Equation (1) and the internal surface temperature for each component at the given time  $t$  for Equation (2)] from the known parameters. The form of these equations depends on the solution technique adopted.

#### 4.4 Boundary conditions

##### 4.4.1 Single room

A single room model requires the knowledge of the conditions of adjacent rooms. The two following situations are considered:

- adjacent room with the same conditions (similar rooms);
- adjacent room with defined internal conditions.

If boundary conditions are very different from the above, the simple room model specified in this International Standard shall not be used and it is necessary to calculate the real boundary conditions by a multi-room model able to take account of the heat transfer between the different rooms. This may be achieved by:

- a) simultaneous solution of the global system equations for all rooms, or
- b) iterative procedure by considering, as boundary conditions for each room, the temperatures determined at the previous time step.

##### 4.4.2 Similar rooms

###### 4.4.2.1 Partition (vertical) wall

Referring to Figure 4, the following boundary conditions are considered as shown in Equation (7):

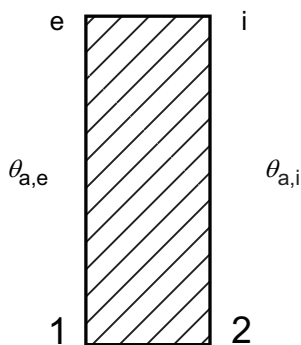

#### Key

- 1 similar
- 2 internal

Figure 4 — Partition vertical wall

$$\begin{aligned} \theta_{a,e} &= \theta_{a,i} \\ q_{sr,e} &= q_{sr,i} \\ q_{lr,e} &= q_{lr,i} \\ h_{c,e} &= h_{c,i} \end{aligned} \tag{7}$$

where

- $\theta_{a,e}$  is the air temperature of the adjacent room;
- $\theta_{a,i}$  is the air temperature of the room;
- $q_{sr,e}$  is the density of heat flow rate due to absorbed short-wave radiation at the external surface of the wall;
- $q_{lr,e}$  is the density of the heat flow rate by long-wave radiation exchanged with the other surfaces of the adjacent room;
- $q_{sr,i}$  is the density of heat flow rate due to absorbed short-wave radiation at the internal surface of the wall (see 4.5.3.2);
- $q_{lr,i}$  is the density of the heat flow rate received by long-wave radiation at the internal surface of the wall from the other internal surfaces (see 4.5.4.2);
- $h_{c,e}$  is the convective heat transfer coefficient at the external surface;
- $h_{c,i}$  is the convective heat transfer coefficient at the internal surface (see Table 1).

#### 4.4.2.2 Ceiling/floor

Referring to Figure 5, the following boundary conditions are considered as shown in Equation (8):

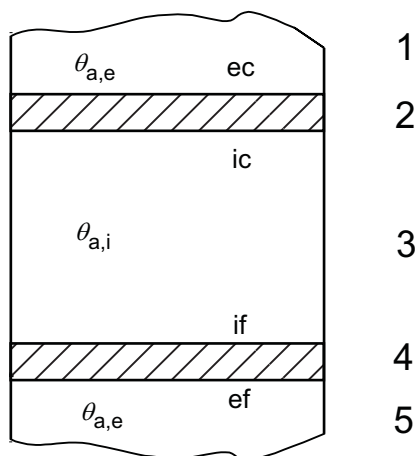

- Key**
- 1 similar room
  - 2 ceiling
  - 3 room
  - 4 floor
  - 5 similar room

Figure 5 — Ceiling/floor adjacent to similar rooms

$$\begin{aligned}
 \theta_{a,e} &= \theta_{a,i} \\
 q_{sr,ec} &= q_{sr,if} \\
 q_{lr,ec} &= q_{lr,if} \\
 q_{sr,ef} &= q_{sr,ic} \\
 q_{lr,ef} &= q_{lr,ic} \\
 h_{c,ec} &= h_{c,if} \\
 h_{c,ef} &= h_{c,ic}
 \end{aligned}
 \tag{8}$$

where

- $\theta_{a,e}$  is the air temperature of the adjacent room;
- $\theta_{a,i}$  is the air temperature of the room;
- $q_{sr,ec}$  is the density of heat flow rate due to absorbed short-wave radiation at the external surface of the ceiling;
- $q_{sr,ic}$  is the density of heat flow rate due to absorbed short-wave radiation at the internal surface of the ceiling (see 4.5.3.2);
- $q_{sr,ef}$  is the density of heat flow rate due to absorbed short-wave radiation at the external surface of the floor;
- $q_{sr,if}$  is the density of heat flow rate due to absorbed short-wave radiation at the internal surface of the floor (see 4.5.3.2);
- $q_{lr,ef}$  is the density of the heat flow rate by long-wave radiation by the external surface of the floor with the other external surfaces;
- $q_{lr,if}$  is the density of the heat flow rate by long-wave radiation by the internal surface of the floor with the other internal surfaces (see 4.5.4.2);
- $q_{lr,ec}$  is the density of the heat flow rate by long-wave radiation from the external surface of the ceiling to the other external surfaces;
- $q_{lr,ic}$  is the density of the heat flow rate by long-wave radiation from the internal surface of the ceiling to the other internal surfaces (see 4.5.4.2);
- $h_{c,ec}$  is the convective heat transfer coefficient at the external surface of the ceiling;
- $h_{c,if}$  is the convective heat transfer coefficient at the internal surface of the floor (see Table 1);
- $h_{c,ef}$  is the convective heat transfer coefficient at the external surface of the floor;
- $h_{c,ic}$  is the convective heat transfer coefficient at the internal surface of the ceiling (see Table 1).

4.4.3 Adjacent room with defined value of the air temperature

For each component of the envelope (see Figure 6) the following boundary conditions are considered as shown in Equation (9):

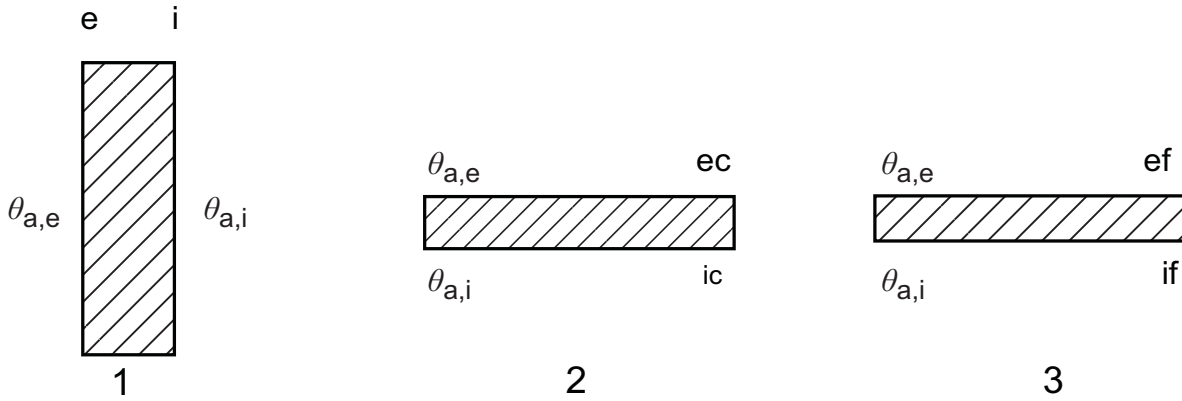

- Key**  
 1 wall  
 2 ceiling  
 3 floor

Figure 6 — Wall, ceiling and floor adjacent to room with defined internal conditions

$$\begin{aligned}
 \theta_{a,e} &= \theta_{a,d} \\
 q_{sr,e} &= 0 \\
 h_{c,e} &= h_{c,i} \\
 h_{c,ec} &= h_{c,if} \\
 h_{c,ef} &= h_{c,ic}
 \end{aligned}
 \tag{9}$$

where

- $\theta_{a,d}$  is the defined air temperature of the adjacent room;
- $q_{sr,e}$  is the density of heat flow rate due to absorbed short-wave radiation at the external surface;
- $h_{c,e}$  is the convective heat transfer coefficient at the external surface of the vertical wall;
- $h_{c,i}$  is the convective heat transfer coefficient at the internal surface of the vertical wall (see Table 1);
- $h_{c,ec}$  is the convective heat transfer coefficient at the external surface of the ceiling;
- $h_{c,if}$  is the convective heat transfer coefficient at the internal surface of the floor (see Table 1);
- $h_{c,ef}$  is the convective heat transfer coefficient at the external surface of the floor;
- $h_{c,ic}$  is the convective heat transfer coefficient at the internal surface of the ceiling (see Table 1).

#### 4.4.4 Floor on ground

The heat transfer between the room and the external environment through the ground is calculated as the sum of a steady state component and a monthly variable component as specified in ISO 13370. The monthly variable component is treated as one-dimensional and perpendicular to the floor surface. The calculation procedure shall combine this heat flow rate with the thermal storage of the floor construction together with a 0,5 m thick layer of soil beneath it as described in ISO 13370.

#### 4.4.5 Cellar or crawl space

A cellar is treated as an unheated basement according to ISO 13370. Heat transfers are calculated as in 4.4.4, including 0,5 m of soil at each side of the cellar and below the cellar. A crawl space is treated as a suspended floor according to ISO 13370. Heat transfers are calculated as in 4.4.4.

#### 4.4.6 Ceiling below attic

According to the assumptions of 4.2.6.1, the boundary conditions are represented by:

$\theta_{a,e}$  is the external air temperature;

$q_{sr,e}$  is defined by Equation (17);

$q_{lr,e}$  is defined by Equation (24).

### 4.5 Terms in the thermal balance equations

#### 4.5.1 Heat conduction through components

For elements with constant thermal conductivity and specific heat capacity, the density of heat flow by conduction is governed by Equations (10) and (11):

$$q_{cd,n} = -\lambda \left( \frac{\partial \theta}{\partial n} \right) \quad (10)$$

$$\lambda \left( \frac{\partial^2 \theta}{\partial x^2} + \frac{\partial^2 \theta}{\partial y^2} + \frac{\partial^2 \theta}{\partial z^2} \right) + g = c_{me} \rho_{me} \frac{\partial \theta}{\partial t} \quad (11)$$

where

$\theta$  is the temperature of the component (in direction of the heat flow) at the time  $t$ ;

$q_{cd,n}$  is the density of heat flow rate in direction  $n$ ;

$\lambda$  is the thermal conductivity of the medium;

$c_{me}$  is the specific heat capacity of the medium;

$\rho_{me}$  is the density of the medium;

$g$  is the heat source term (heat flow rate per volume);

$x, y, z$  are co-ordinates.

These equations may be solved by any appropriate procedure which provides results in accordance with the validation procedure given in Clause 7.

NOTE A suitable procedure is described in Annex A.

.....

4.5.2 Convective heat transfer

4.5.2.1 General

Convective heat transfer occurs at the boundary surfaces of each building element and through air layers.

4.5.2.2 Convective heat flow rate at the surfaces of an element

The density of convective heat flow rate at the internal and external surface of element is given by Equation (12):

$$q_c = h_c(\theta_s - \theta_a) \tag{12}$$

where

- $h_c$  is the convective heat transfer coefficient of the surface;
- $\theta_s$  is the surface temperature;
- $\theta_a$  is the air temperature.

At the external surface the values of the convective heat transfer coefficient  $h_{c,e}$ , are given by Equation (13):

$$h_{c,e} = 4 + 4 \times v \tag{13}$$

where  $v$  is the wind velocity near the surface.

The wind velocity near the surface,  $v$ , depends on the climatic data of the locality and on the envelope characteristics. Unless otherwise specified, the value of 1 m/s shall be used. The values of the convective heat transfer coefficient at the internal surface,  $h_{c,i}$ , are given in Table 1.

**Table 1 — Convective heat transfer coefficient at the internal surface**

Vertical wall W/(m <sup>2</sup> ·K)	Heat flow upwards W/(m <sup>2</sup> ·K)	Heat flow downwards W/(m <sup>2</sup> ·K)
2,5	5,0	0,7
NOTE The values in this table were determined using the equations given in ISO 6946 for the following conditions: — temperature difference ( $\theta_{s,i} - \theta_{a,i}$ ) < 10 K; — surface hydraulic diameter = 4,5 m (4 × area/perimeter).		

The air temperature required in Equation (12) is:

- for internal surfaces: the room air temperature;
- for external surfaces: the conditions given in Table 2.



Table 2 — Air temperature

Building elements	Air temperature conditions
External wall, roof	External air temperature
Partition wall, ceiling and roof to similar room	Internal air temperature
Partition wall, ceiling and roof to adjacent room with different conditions	Air temperature of the adjacent room
Floor on ground	Mean monthly external air temperature
Floor on cellar	Temperature of the cellar

#### 4.5.2.3 Convective heat transfer through unventilated air layers

The density of convective heat flow rate through an unventilated air layer,  $q_c$ , is given by Equation (14):

$$q_c = A_a \Delta\theta \quad (14)$$

where

$\Delta\theta$  is the temperature difference between the surfaces delimiting the layer;

$A_a$  is the thermal conductance of the air layer.

The thermal conductance of an unventilated air layer is calculated according to:

- ISO 6946 between opaque surfaces;
- ISO 10077-1, ISO 10077-2, ISO 15099, ISO 10292 or EN 673 between transparent surfaces.

NOTE For transparent surfaces, the thermal conductance of an unventilated air layer can be calculated assuming the following reference conditions:

- air density: 1,139 kg/m<sup>3</sup>
- dynamic viscosity: 1,861 × 10<sup>-5</sup> kg/(m·s)
- thermal conductivity: 0,026 4 W/(m·K)
- specific heat capacity: 1 008 J/(kg·K)
- thermodynamic temperature: 300 K
- temperature difference: 5 K

Table 3 gives some values of thermal conductance,  $A_a$ , for vertical and horizontal unventilated air layers between transparent components. For other thicknesses, thermal conductance may be derived by interpolation.

**Table 3 — Thermal convective conductance of unventilated air layers between opaque surfaces (calculated in accordance with ISO 6946)**

Air layer thickness m	Vertical air layer	Horizontal air layer	
	Thermal conductance $\lambda_a$ W/(m <sup>2</sup> ·K)	Heat flow upwards	Heat flow downwards
		Thermal conductance $\lambda_a$ W/(m <sup>2</sup> ·K)	Thermal conductance $\lambda_a$ W/(m <sup>2</sup> ·K)
0,01	2,50	2,50	2,50
0,05	1,25	1,95	0,50
0,10	1,25	1,95	0,33
0,20	1,25	1,95	0,24

**Table 4 — Thermal convective conductance of unventilated air layers between transparent surfaces (calculated in accordance with EN 673)**

Air layer thickness m	Vertical air layer	Horizontal air layer	
	Thermal conductance $\lambda_a$ W/(m <sup>2</sup> ·K)	Heat flow upwards	Heat flow downwards
		Thermal conductance $\lambda_a$ W/(m <sup>2</sup> ·K)	Thermal conductance $\lambda_a$ W/(m <sup>2</sup> ·K)
0,01	2,64	2,64	2,64
0,025	1,06	2,00	1,06
0,05	1,16	1,79	0,53
0,10	1,28	1,60	0,26
0,20	1,41	1,43	0,13

NOTE The value corresponding to 25 mm thickness is necessary for interpolation.

**4.5.2.4 Convective heat transfer through ventilated air layer**

The convective heat flow rate through a ventilated air layer,  $\Phi_{va}$ , depends on the air flow rate in the air layer. The heat flow rates to be considered are:

- a) the convective heat flow rate,  $\Phi_{va}$ , due to air passing through the air layer and into the room, given by Equation (15):

$$\Phi_{va} = m_{a,v} c_a (\theta_l - \theta_{a,i}) \tag{15}$$

where

$m_{a,v}$  is the mass air flow through the air layer;

$\theta_l$  is the temperature of the air leaving the layer;

b) the convective heat flow rate,  $\Phi_{c,j}$ , between surfaces and air, given by Equation (16):

$$\begin{aligned}\Phi_{c,j} &= h_a A_c (\theta_j - \theta_{eq}) \\ \Phi_{c,j+1} &= h_a A_c (\theta_{j+1} - \theta_{eq})\end{aligned}\quad (16)$$

where

- $A_c$  is the area of the surface in contact with the air layer;
- $h_a$  is the convective heat transfer coefficient for ventilated layers;
- $\theta_{eq}$  is the equivalent temperature of the air in the layer;
- $j$  and  $j + 1$  is the surfaces delimiting the air layer.

NOTE A procedure for determining the parameters in Equations (15) and (16) is given in Annex B.

### 4.5.3 Short-wave radiation heat transfers

#### 4.5.3.1 Short-wave radiation heat transfer at the external surface of opaque element

The density of short-wave radiation heat flow rate at the external surface of an opaque element is given by Equation (17):

$$q_{sr,e} = \alpha_{sr} (f_s I_D + I_d) \quad (17)$$

where

- $\alpha_{sr}$  is the solar absorptance;
- $f_s$  is the sunlit factor;
- $I_D$  is the direct component of the solar radiation reaching the surface;
- $I_d$  is the diffuse component of the solar radiation reaching the surface.

The values of solar absorptance of external opaque surfaces,  $\alpha_{sr}$ , depend on the characteristics of the external surface of the element. Table 5 gives values of the solar absorptance as a function of the colour of the external surface that may be used when no specific values are available.

**Table 5 — Solar absorptance of external opaque surfaces**

	Light colour	Intermediate colour	Dark colour
$\alpha_{sr}$	0,3	0,6	0,9

The values of the direct,  $I_D$ , and diffuse,  $I_d$ , components of the solar radiation reaching the differently oriented surfaces may be derived from national data.

The sunlit factor,  $f_s$ , is given by Equation (18):

$$f_s = \frac{A_s}{A} \quad (18)$$

where

$A_s$  is the sunlit area of the wall (defined in 4.5.3.5);

$A$  is the total area of the wall.

#### 4.5.3.2 Short-wave radiation heat transfer at the internal surface of opaque elements

The density of heat flow rate by short-wave radiation absorbed at the internal surface of an opaque element is given by Equation (19):

$$q_{sri} = (1 - f_{sa})(1 - f_{sl})(\Phi_{sr,D} + \Phi_{sr,d})f_d \quad (19)$$

where

$f_{sa}$  is the solar to air factor of the room;

$f_{sl}$  is the solar loss factor of the room;

$f_d$  is the distribution factor of the solar radiation at the internal surface of the element;

$\Phi_{sr,D}$  is the heat flow rate due to the direct component of solar radiation entering the room;

$\Phi_{sr,d}$  is the heat flow rate due to the diffuse component of solar radiation entering the room.

The heat flow rates due to the direct and diffuse components of the solar radiation entering the room are given by Equations (20) and (21), respectively:

$$\Phi_{sr,D} = \sum_{j=1}^J (I_D \tau_D A_s)_j \quad (20)$$

$$\Phi_{sr,d} = \sum_{j=1}^J (I_d \tau_d A)_j \quad (21)$$

where

$J$  is the number of glazing systems;

$I_D$  is the direct component of solar radiation reaching the external surface of the system  $j$ ;

$I_d$  is the diffuse component of solar radiation reaching the external surface of the glazing system  $j$ ;

$\tau_D$  is the direct solar transmittance of the glazing system;

$\tau_d$  is the diffuse solar transmittance of the glazing system;

$A_s$  is the sunlit area of the glazing (see 4.5.3.5);

$A$  is the glazing area.

The direct and diffuse solar transmittance of each glazing system  $\tau_D$  and  $\tau_d$  shall be determined according to ISO 9050 or EN 410. If no values are available,  $\tau_D$  and  $\tau_d$  shall be calculated at the normal incident angle.

### Solar to air factor

The solar to air factor,  $f_{sa}$ , is the fraction of solar heat entering the room through the glazing which is immediately transferred to the internal air. This fraction depends on the quantity of internal items with very low thermal capacity such as carpets and furniture. It is assumed to be time-independent.

### Solar loss factor

The solar loss factor,  $f_{sl}$ , is the fraction of the solar radiation entering the room which is reflected back to the external environment. It depends on the geometrical characteristics and solar properties of the glazing system, the exposure of the glazing, the solar angles and the room geometry and colour of the surfaces. It is assumed to be time-independent.

### Distribution factors

The distribution factors,  $f_d$ , define the amount of the direct solar radiation absorbed per area at the different internal surfaces of the walls, ceiling, floor, etc. They depend on the solar angles, the geometrical dimensions of glazing and room, the short-wave reflectance of components, and the furniture and furnishings. It is assumed to be time-independent.

NOTE Unless otherwise specified, values of  $f_{sa}$ ,  $f_{sl}$  and  $f_d$  given in informative Annex G can be used.

#### 4.5.3.3 Short-wave radiation heat flow rate for transparent elements (including blinds and curtains)

Transparent elements partially transmit, reflect and absorb the solar radiation impinging on their external surface. For multi-layered glazed elements (e.g. double pane window with internal and/or external blind) the following solar parameters are required:

- direct and diffuse solar energy transmittance of the system,  $\tau_D$  and  $\tau_d$ ;
- equivalent direct and diffuse solar energy absorptance of each component of the glazed system,  $\alpha'_{sr}$ .

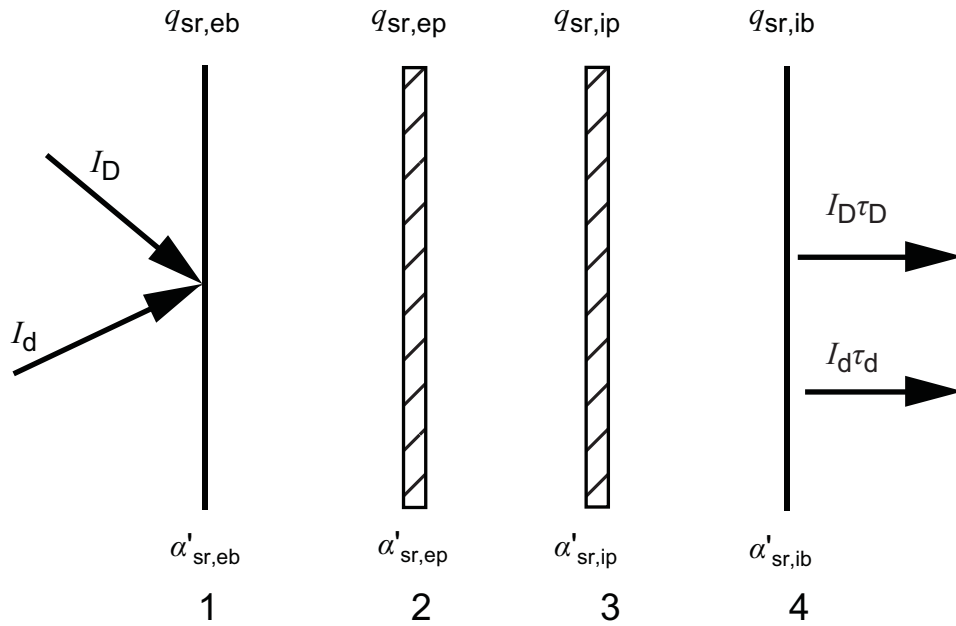

- Key**
- 1 external blind (eb)
  - 2 external pane (ep)
  - 3 internal pane (ip)
  - 4 internal blind (ib)

**Figure 7 — Double pane with internal and external blinds**

These solar parameters shall be calculated according to ISO 9050 or EN 410, taking into account the solar energy transmittance and reflectance of each component. If no data are available for various incident angles, values of these parameters at the normal incident angle can be taken as safe values. The density of heat flow rate for element *j* of the glazing system due to the absorbed solar radiation is then determined in Equation (22) as:

$$q_{sr,j} = \alpha'_{sr,j}(I_D f_s + I_d) \tag{22}$$

where

*j* is the element of the glazing system;

$\alpha'_{sr}$  is the equivalent solar absorptance.

If curtains or venetian blinds are present, the following situations can occur:

- a) curtain/blind completely closed;
- b) curtain/blind not completely closed.

In case a) the glazing component and the curtain/blind are treated as a single envelope component having appropriate solar coefficients.

In case b) two different components shall be considered:

- the portion of glazing area not covered by the curtain/blind, comprising the glazing component only;
- the portion of glazing area covered by the curtain/blind, treated as in case a).

#### 4.5.3.4 Solar to air heat flow rate

The solar to air heat flow rate,  $\Phi_{sa}$ , is the heat flow rate due to solar radiation, entering through the glazing system, directly transferred to the internal air. It is given by Equation (23):

$$\Phi_{sa} = f_{sa}(1 - f_{sl})(\Phi_{sr,D} + \Phi_{sr,d}) \quad (23)$$

The parameters in Equation (23) are the same as in Equation (19).

#### 4.5.3.5 Sunlit area of room element

When external obstructions are present, the area of an element can be partially shaded. Obstructions considered in this International Standard are: horizontal overhangs, side fins, window set back and surrounding constructions. A sunlit factor is defined in Equation (18) and may be added for the diffuse radiation in Equations (17) and (22). For the sake of safety, it may be assumed that:

- the effect of shading is only to reduce the direct solar component;
- the effect of mutual reflections is negligible.

The evaluation of the sunlit area may be obtained by any appropriate procedure that provides results in accordance with the validation tests given in Clause 7.

NOTE A suitable procedure is described in Annex C.

### 4.5.4 Long-wave radiation heat transfer

#### 4.5.4.1 Heat flow rate at the external surface

According to the assumptions of 4.1, the density of net long-wave radiant heat flow rate received by an external surface,  $q_{lr}$ , is given by Equation (24):

$$q_{lr} = h_{lr}(\theta_{a,e} - \theta_{s,e}) - q_{sk} \quad (24)$$

where

$h_{lr}$  is the long-wave radiative heat transfer coefficient;

$\theta_{a,e}$  is the external air temperature;

$\theta_{s,e}$  is the external surface temperature;

$q_{sk}$  is the correction for the long-wave radiation exchanges from the wall to the sky.

Using thermodynamic temperatures ( $T = \theta + 273,15$ ), the value of  $h_{lr}$  is approximated by Equation (25):

$$h_{lr} = 4 \times \varepsilon \sigma \left( \frac{T_{a,e} + T_{s,e}}{2} \right)^3 \quad (25)$$

where

$\varepsilon$  is the long-wave emissivity of the surface;

$\sigma$  is the Stefan-Boltzmann constant;

$T_{a,e}$  is the external air temperature;

$T_{s,e}$  is the surface temperature.

According to the assumptions of 4.1, the calculations shall be made with a fixed value of  $h_{lr}$ .

NOTE 1 The terms of Equation (24) can be calculated with the following conditions:

- emissivity of the external surface  $\varepsilon_{lr,e} = 0,93$ ;
- reference temperature  $T_m = \frac{T_{a,e} + T_{s,e}}{2} = 303 \text{ K}$ .

Under these conditions, the value of  $h_{lr,e}$ , for external surfaces, is  $5,5 \text{ W/(m}^2\cdot\text{K)}$ .

The correction for the long-wave radiation emitted from the element to the sky,  $q_{sk}$ , is given by Equation (26):

$$q_{sk} = F_{sk} \times 4 \times \varepsilon \sigma \left( \frac{T_{a,e} + T_{sk}}{2} \right)^3 (T_{a,e} - T_{sk}) \quad (26)$$

where

$F_{sk}$  is the view factor from the element with the sky (solid angle divided by  $2\pi$ );

$T_{a,e}$  is the external air temperature;

$T_{sk}$  is the temperature of the sky.

The temperature of the sky depends on the characteristics of the atmosphere and its vapour content. Values of these parameters are fixed at national level.

NOTE 2 If no information is available, the procedure of Annex E can be used for determining the various parameters. Equation (F.2) (valid for clear sky) can be used for determining the temperature of the sky; Equation (F.5) can be used for determining the correction term  $q_{sk}$ .

#### 4.5.4.2 Heat flow rate at the internal surface

The density of net long-wave radiant heat flow rate,  $q_{lr}$ , received by the internal surface  $j$ , is given by Equation (27):

$$q_{lr,j} = \sum_{k=1}^N (F_{j,k} J_{lr,k}) - J_{lr,j} \quad (27)$$

where

$N$  is the number of surfaces delimiting the environment;

$F_{j,k}$  is the view factor from surface  $j$  to surface  $k$ ;

$J_{lr,j}$  is the long-wave radiosity of the surface  $j$ ;

$J_{lr,k}$  is the long-wave radiosity of the surface  $k$ ;

$F_{j,k}$  is the mean value, over surface  $j$ , of a solid angle over which surface  $k$  is seen from a point on surface  $j$ , divided by  $2\pi$ .

The long-wave radiosity of a surface is the total density of heat flow rate emitted and reflected by this surface, all surfaces being here considered as grey bodies. Thus the long-wave radiosity of surface  $j$  is shown in Equation (28):

$$J_{lr,j} = \rho_j \sum_{k=1}^N (F_{j,k} J_{lr,k}) + \varepsilon_j \sigma T_j^4 \quad (28)$$



where

- $\rho$  is the long-wave radiative reflectance;
- $\varepsilon$  is the long-wave radiative emittance;
- $\sigma$  is the Stefan-Boltzmann constant.

In order to calculate the long-wave radiant heat flow exchanged by the  $N$  different inside surfaces, the radiosity  $J_{lr}$  for each surface shall be first determined by solving the  $N$  simultaneous equations. The solution of Equation (27) shall be carried out for the various surfaces bounding the room.

Equation (27) may be solved by any appropriate procedure which provides results in accordance with the validation procedure given in Clause 7.

NOTE A suitable procedure is described in Annex F.

#### 4.5.4.3 Air layers

The density of long-wave radiative heat transfer through air layers is given by Equation (29):

$$q_{lr} = A_{lr} \Delta\theta \quad (29)$$

where

- $\Delta\theta$  is the temperature difference between the surfaces delimiting the air layer;
- $A_{lr}$  is the long-wave radiative conductance of the air.

The long-wave radiative conductance is given in:

- ISO 10077-1, ISO 15099, ISO 10292 or EN 673 for an air layer between glazing surfaces;
- ISO 6946 for an air layer between opaque layers.

For ordinary surfaces the following values are considered:

- opaque surface ( $\varepsilon = 0,93$ )  $A_{lr} = 5,0 \text{ W}/(\text{m}^2 \cdot \text{K})$ ;
- transparent surfaces ( $\varepsilon = 0,837$ )  $A_{lr} = 4,4 \text{ W}/(\text{m}^2 \cdot \text{K})$ ;
- opaque surface ( $\varepsilon = 0,93$ ) and transparent surface ( $\varepsilon = 0,837$ )  $A_{lr} = 4,6 \text{ W}/(\text{m}^2 \cdot \text{K})$ .

#### 4.5.5 Internal gains

Internal gains usually derive from lighting, equipment and occupants. The relevant heat flow rate includes a convective component,  $\Phi_{i,c}$ , and a long-wave radiative component,  $\Phi_{i,r}$ , which are respectively included in Equations (1) and (2). The total radiative component,  $\Phi_{i,r}$ , is supposed to be uniformly distributed on all the internal surfaces bounding the room, including windows.

NOTE Unless otherwise specified, the heat flow rate values given in Annex H for internal sources can be used.

#### 4.5.6 Heat flow due to ventilation

##### 4.5.6.1 General

The net heat flow rate to the room air due to natural and mechanical ventilation is calculated in Equation (30) as:

$$\Phi_v = c_a m_a (\theta_{i1} - \theta_{a,i}) \quad (30)$$

where

$c_a$  is the specific heat capacity of the inlet air;

$m_a$  is the mass air flow rate;

$\theta_{i1}$  is the inlet air temperature;

$\theta_{a,i}$  is the internal air temperature.

The inlet air temperature depends on its source (e.g. external air or adjacent room). The mass air flow rate results from natural and/or forced ventilation.

##### 4.5.6.2 Natural ventilation

The air flow rate due to natural ventilation depends on the dimensions and type of cracks and openings (including doors and windows), the temperature difference, the wind speed and its direction. It is given by Equation (31):

$$m_a = c_d \rho A \left( \frac{2 \times \Delta p}{\rho} \right)^n \quad (31)$$

where

$c_d$  is the coefficient of discharge;

$A$  is the area of the opening;

$\Delta p$  is the pressure difference between internal and external environments;

$\rho$  is the density of the air;

$n$  is a coefficient between 0,5 and 1.

The values of coefficients  $c_d$ ,  $n$  and area  $A$  depend on the position and flow characteristics of all openings. It is assumed that the air in the room is well mixed.

NOTE Annex I gives a suitable procedure to evaluate the volumetric air flow rate by natural ventilation.

##### 4.5.6.3 Mechanical ventilation

The mass air flow rate due to forced ventilation depends on the characteristics of the supply/exhaust system.

## 5 Determination of internal humidity

Not only temperature but also humidity affects the indoor thermal environment. In particular, high internal humidity is likely to increase discomfort in a region under a humid climatic condition. On the other hand, excessively low humidity may cause adverse effects on health, such as dry skin and respiratory diseases. In these cases, internal humidity as well as temperature plays a critical role.

When the temperature of walls is low, high internal humidity increases the possibility of condensation.

In consideration of these aspects, it is desirable to know internal humidity as well as internal air temperature in order to create an appropriate indoor environment.

This International Standard does not deal with the effects of mechanical cooling. However, information about internal humidity is essential to determine whether dehumidification or cooling is needed, as described in Introduction, c).

Annex K provides a general overview of the calculation method for internal humidity, which is similar to that of internal air temperature (see 4.2.1). Annex K describes the calculation considering only the influx and outflux of moisture due to internal moisture production and ventilation, on the assumption that “walls and other internal items such as furniture and books” (described as “walls and others” from here on) do not absorb or desorb moisture. For the calculation considering moisture absorption into or desorption from walls and others, refer to Reference [15] in the Bibliography. This calculation can be somewhat more complex than that of considering only temperature because heat and moisture in walls and others interact with each other.

The indoor humidity is determined by the moisture production rate,  $G$ , and the air exchange rate. It can be given by Equation (32) under a steady state condition.

$$v_i = v_e + \frac{G}{q_a / \rho} \quad (32)$$

## 6 Procedure for carrying out calculations

### 6.1 General

This International Standard is used for calculating the internal temperatures (air and internal surfaces) for the intended purposes given in Clause 1. It should, however, be noted that these “predicted internal temperatures” are determined on the basis of a set of assumptions described in various clauses of this International Standard. Using a different set of assumptions, e.g. boundary conditions or surface coefficients, will lead to a different set of “predicted internal temperatures”. Furthermore, the calculations for determining “predicted internal temperatures” shall be carried out according to the procedure and values for the design climate data, design geometric and thermophysical characteristics of the room, and its components, and the design internal gains as defined below.

### 6.2 Design climatic data

#### 6.2.1 General

The calculation method uses time varying values of various climatic data. The time period and the type of climatic data used affect the calculation of internal temperatures. Identification of the design days and calculation of hourly data from files of meteorological data shall be calculated in accordance with the procedures described in ISO 15927-2.

The design climatic data may be given in a national annex to this International Standard according to the following methods:

- long-period design climatic data;
- design warm sequence.

### 6.2.2 Long-period design climatic data

If the internal temperatures are determined from a long period of climatic data, the hourly values of the following are required for the whole of the period considered: the value of direct and diffuse solar radiation components on the various facades, the external air temperature, the wind velocity and its prevailing direction. Climatic data may be given in a national annex to this International Standard.

### 6.2.3 Design warm sequence

Such a sequence of several days shall be chosen so as to be representative of the hottest conditions for a given climate. Because the hottest internal conditions do not necessarily coincide with the warmest external conditions, it may be necessary to consider the different climatic situations for several months. For each month, the design warm sequence shall be defined by:

- hourly values of direct and diffuse (sky and ground reflected) components of solar radiation on the various facades;
- hourly values of the external air temperature;
- hourly values of the wind velocity and its prevailing direction.

NOTE Annex D gives a procedure for deriving the design warm sequences.

The starting internal conditions are calculated by using the average monthly values of:

- hourly values of direct and diffuse (sky and ground reflected) components of solar radiation on the various facades;
- hourly values of the external air temperature;
- mean monthly value of the wind velocity and its prevailing direction.

## 6.3 Geometrical and thermophysical characteristics of room elements

The appropriate boundary conditions are given in 4.4. For each element the following properties shall be provided:

- a) geometrical properties: width and height (or length and width) of each component measured from the internal surfaces;
- b) thermophysical properties: thermal conductivity, density and specific heat of each layer of layered elements and thermal resistance of air gaps and window/blind thermal characteristics.

## 6.4 Design internal gains

Internal gains are generally due to occupants, equipment and lights. These contributions vary with occupant behaviour. Design internal gains may be given in a national annex to this International Standard.

NOTE Annex H gives data which can be used unless other data are available.

## 6.5 Design occupant behaviour

Occupant behaviour greatly modifies the internal conditions of a room. The occupants influence the amount of internal heat sources, natural ventilation, and blind arrangements. The reference behaviour to introduce in the “design” calculation may be defined from national data. For a design calculation, the time of opening and closing of a window, the area of opening and the type of blind, shall be fixed.

Design occupant behaviour may be given in a national annex to this International Standard.

## 6.6 Calculation procedure

### 6.6.1 General

The internal temperatures are determined by applying the calculation procedure defined in 4.4 and 4.5, considering the climatic data (see 6.2), the geometrical and thermophysical characteristics of the room elements (see 6.3), the internal gains (see 6.4), the occupant behaviour (see 6.5), and the starting conditions defined below. The calculation procedure involves the two consecutive steps:

- a) evaluation of the starting conditions;
- b) evaluation of the design internal conditions.

### 6.6.2 Definition of the starting conditions

If the long-period design climatic data are used, the calculation shall be carried out for at least two weeks and the resulting conditions shall be used as the starting conditions. If the design warm sequence is used, the starting conditions are obtained by repeating the calculation given in 4.2 and 4.3 for the mean monthly values of the climatic data defined in 6.2.3, until the predicted internal air temperature over two consecutive days differs by less than 0,01 K. These conditions are then used as the starting conditions.

### 6.6.3 Prediction of the internal temperatures

The internal temperatures are determined using, as initial conditions, the internal conditions evaluated in 6.6.1. For long-period design climatic data, the internal temperatures are determined hour by hour by considering climatic data defined in 6.2.2. For the design warm sequence, the internal temperatures are determined by iterating the procedures in 4.2 and 4.3, using the climatic data corresponding to the design warm sequence. The number of days depends on the characteristics of the local climatic data. The hourly values of the internal temperature shall be calculated as the average over each hour.

## 7 Report of the calculation

The calculation report shall include the input data adopted and the results of the calculation.

### a) Input data:

- climatic data (hourly values of the external air temperature and solar radiation intensity);
- building characteristics: description of the building and of the rooms investigated;
- volume of room;
- for each element bounding the room:
  - opaque elements: area, exposure, thermophysical properties of each layer;
  - glazed elements: area, exposure, thermophysical and solar characteristics of each glazed element.

Local clock time shall be used for all time-dependent input data with the exception of climatic data. If the climatic data time convention is different from local clock time, the difference shall be reported.

### b) Results:

- hourly values of the air ventilation flow rate (number of changes per hour);
- hourly values of the heat flow rate for internal sources (watts per square metre of floor area);

- hourly values of air temperature and mean radiant temperature.

The predicted temperatures shall be reported for the calculation period and not for the pre-conditioning period.

## 8 Validation procedures

### 8.1 Introduction

This International Standard does not impose any specific numerical technique for the calculation of internal temperatures of a single room. The annexes give procedures for the calculation of the different parameters necessary for determining the internal temperature, according to the assumptions included in this International Standard.

Any existing or new numerical solution which claims conformity with this International Standard shall be validated with the tests in this section and be in agreement with the procedures and assumptions.

The results provided by any numerical solution model shall be within the range indicated for each test. The validation procedures refer both to each relevant heat transfer process and to the whole solution model.

NOTE The check of existing or new solution models can be made by the producers of the numerical solution models as well as the producers of computer programs.

### 8.2 Validation of heat transfer processes

#### 8.2.1 General

Checks shall be made of the following processes:

- heat conduction through opaque elements;
- internal long-wave radiation heat exchanges;
- evaluation of short-wave radiation heat transfer (calculation of shaded area of a window due to external obstructions).

#### 8.2.2 Heat conduction through opaque elements

This procedure requires the evaluation of the internal air temperature of the room specified below at several time intervals.

- Characteristics of the room:

- internal dimensions 1 m × 1 m × 1 m;
- all elements, including ceiling and floor, are identical with the same boundary conditions;
- the short-wave radiative heat transfer is assumed to be zero;
- the air flow rate due to the ventilation is assumed to be zero;
- the internal convective heat transfer coefficient of each element, including ceiling and floor, is  $h_{c,i} = 2,5 \text{ W/(m}^2\cdot\text{K)}$ ;
- the external convective heat transfer coefficient of each element, including ceiling and floor, is  $h_{c,e} = 8 \text{ W/(m}^2\cdot\text{K)}$ ;

- the emissivities of the internal and external surface of each element, including ceiling and floor, are assumed to be zero (the long-wave radiative heat transfer on the internal and external surfaces are assumed to be zero);
- the thermal capacity of the room air is assumed to be zero.

b) Boundary conditions:

- the external air temperature is variable according to Figure 8;
- $t \leq 0$ :  $\theta_{a,e} = 20 \text{ }^\circ\text{C}$ ; for  $0 < t \leq 1$  (hour): linear variation of the external temperature  $\theta_{a,e}$  from  $20 \text{ }^\circ\text{C}$  to  $30 \text{ }^\circ\text{C}$ ;  $t > 1 \text{ h}$ :  $\theta_{a,e} = 30 \text{ }^\circ\text{C}$ ;
- the internal air temperature  $\theta_{a,i}$  is constant at  $20 \text{ }^\circ\text{C}$  for  $t \leq 0$ .

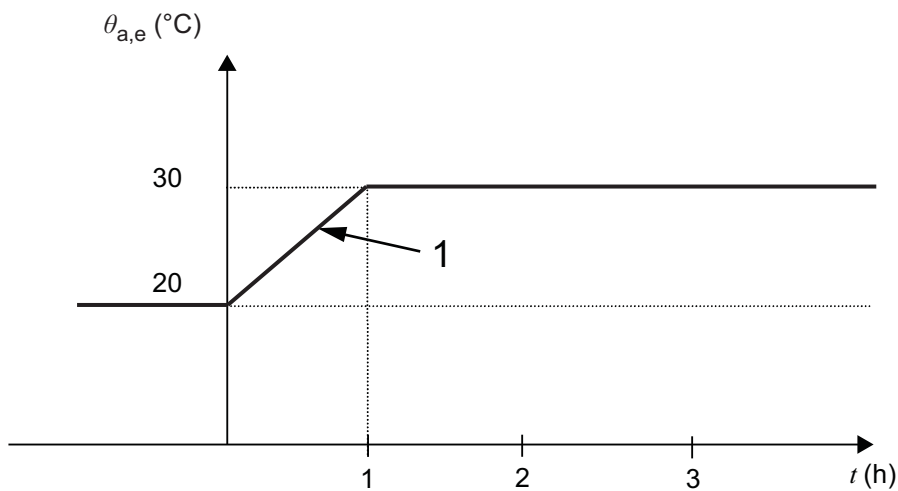

**Key**

- 1 linear variation of the external temperature

**Figure 8 — Variation of the external air temperature**

**Data to be calculated:** the internal air temperature shall be determined after the following times:

- a) 2 h; b) 6 h; c) 12 h; d) 24 h; e) 120 h.

Tests shall be conducted for the room elements given in Table 6.

**Table 6 — Characteristics of the room elements**

Test No.	Thickness <i>d</i> m	Thermal conductivity $\lambda$ W/(m·K)	Density $\rho$ kg/m <sup>3</sup>	Specific heat capacity <i>c</i> kJ/(kg·K)
1	0,20	1,2	2 000	1,0
2 <sup>a</sup>	0,10	0,04	50	1,0
3 <sup>a</sup>	0,20	1,2	2 000	1,0
	0,10	0,04	50	1,0
	0,005	0,14	800	1,5
4 <sup>a</sup>	0,005	0,14	800	1,5
	0,10	0,04	50	1,0
	0,20	1,2	2 000	1,0

<sup>a</sup> Material layers are listed starting from the external side of the element.

For each test, the differences between the values of the internal air temperature, for each time considered, shall be less than 0,5 K from the values given in Table 7.

**Table 7 — Reference values of the internal air temperature, in °C**

Test	Time				
	2 h	6 h	12 h	24 h	120 h
1	20,04	21,26	23,48	26,37	30,00
2	25,09	29,63	30,00	30,00	30,00
3	20,00	20,26	21,67	24,90	29,95
4	20,00	20,06	20,25	20,63	23,17

**8.2.3 Internal long-wave radiation exchanges**

The validation procedure is based on the calculation, in steady-state conditions, of the internal air temperature of various rooms having opaque walls, and adjacent to spaces with different external air temperatures. Referring to the various tests indicated below, the thermal conductance of surface No. 2 (external wall) is  $\Lambda = 5,0 \text{ W}/(\text{m}^2\cdot\text{K})$ ; the thermal conductance of the other walls (partition vertical walls, ceiling and floor) is  $\Lambda = 1,0 \text{ W}/(\text{m}^2\cdot\text{K})$ . The room geometries for the various tests are given in Table 8, and Figures 9 a), 9 b), 9 c) and 9 d).

**Table 8 — Room geometry**

Test No.	Surface No. 1 Partition vertical wall m <sup>2</sup>	Surface No. 2 External vertical wall m <sup>2</sup>	Surface No. 3a) + 3b) + 3c) Partition vertical wall m <sup>2</sup>	Surface No. 4 Ceiling m <sup>2</sup>	Surface No. 5 Floor m <sup>2</sup>	Volume m <sup>3</sup>
1	1	1	2	1	1	1
2	18	12	30	24	24	72
3	9	90	99	90	90	270
4	18	6	36	24	24	72



The boundary conditions considered in the various tests are given in Table 9.

**Table 9 — Boundary conditions**

Surface	External air temperature $\theta_{a,e}$ °C	Surface coefficient of heat transfer			Total hemispherical emissivity $\varepsilon$
		$h_{lr}$ W/(m <sup>2</sup> ·K)	$h_{c,e}$ W/(m <sup>2</sup> ·K)	$h_{c,i}$ W/(m <sup>2</sup> ·K)	
Surface No. 2	30	5,5	8	2,5	0,9
Other surfaces	20	5,5	8	2,5	0,9

The internal surface of wall No. 2 of each geometry absorbs a short-wave radiative density of heat flow rate equal to 100 W/m<sup>2</sup>, time-independent. For other surfaces, the short-wave radiative density of heat flow rate is zero. For test No. 4 the surface No. 2 (4 m × 1,5 m) is the external wall.

Dimensions in metres

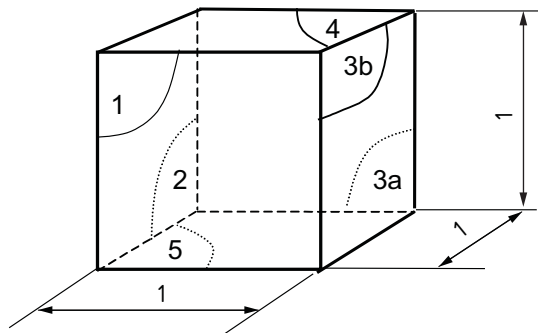

**a) Test No. 1: cubic geometry (1 m × 1 m × 1 m)**

Dimensions in metres

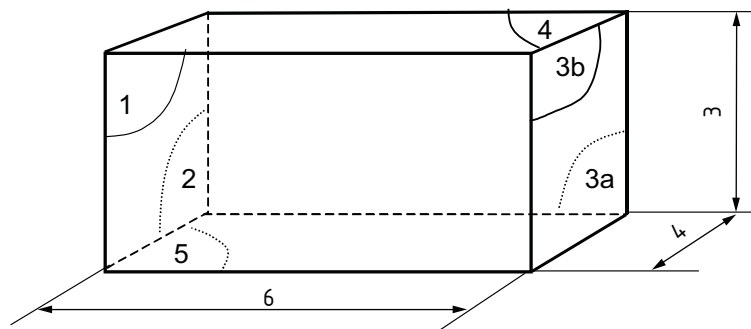

**b) Test No. 2: non-cubic geometry (3 m × 6 m × 4 m)**

**Figure 9 (continued)**

Dimensions in metres

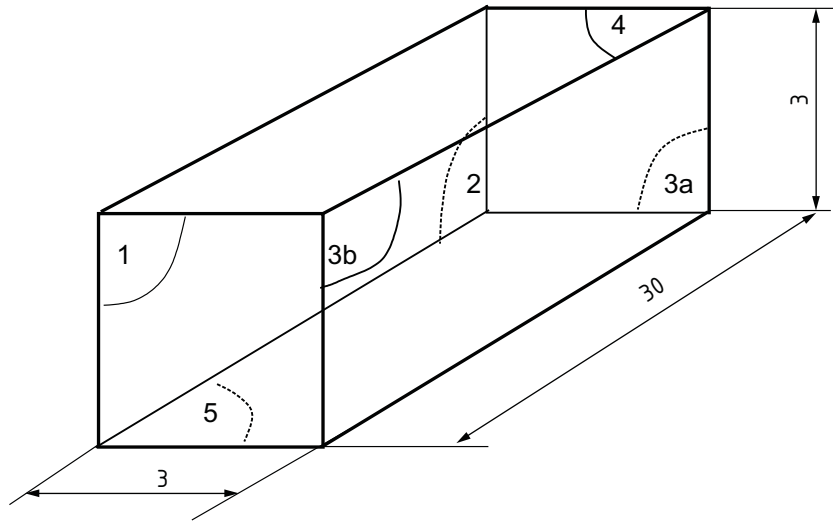

c) Test No. 3: non-cubic geometry (3 m × 30 m × 3 m)

Dimensions in metres

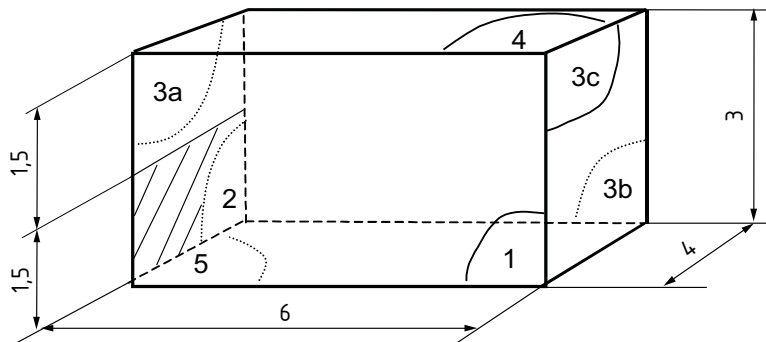

d) Test No. 4: configuration (6 m × 4 m × 3 m) with a seventh surface

Figure 9 — Room geometries

The values obtained shall not differ by more than 0,5 K from those in Table 10.

Table 10 — Internal air temperature, in °C

	Test No. 1	Test No. 2	Test No. 3	Test No. 4
Result	34,4	30,4	38,5	25,5

### 8.2.4 Sunlit area of a window due to external obstructions

The validation procedure requires the evaluation of the sunlit factor  $f_s$  defined in Equation (18) as the ratio between the sunlit area of the plane surface and its total area, for the following tests:

**Test No. 1:** South orientation (Northern hemisphere) — see Figure 10 a): overhang;

**Test No. 2:** South orientation (Northern hemisphere)

— see Figure 10 b): side fins;

**Test No. 3:** South orientation (Northern hemisphere)

— see Figure 10 c): overhang + side fins;

**Test No. 4:** South orientation (Northern hemisphere)

— see Figure 10 d): external obstruction;

**Test No. 5:** East orientation

— see Figure 10 e): overhang + side fins;

**Test No. 6:** East orientation

— see Figure 10 f): external obstruction.

Dimensions in metres

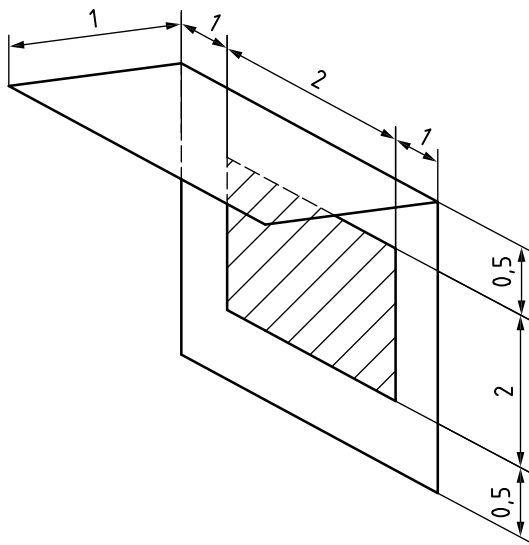

**a) Test No. 1: South orientation (Northern hemisphere)**

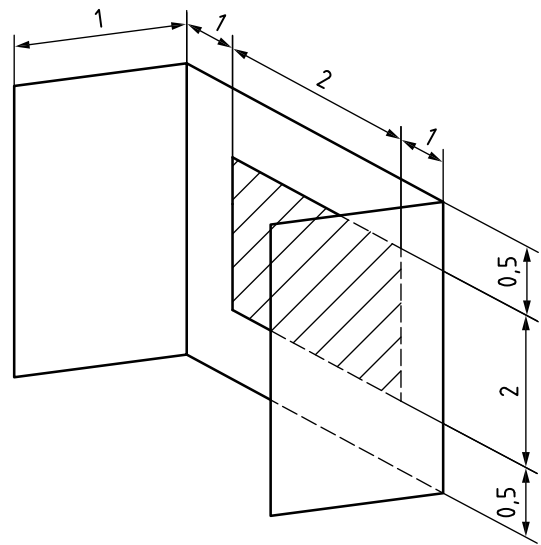

**b) Test No. 2: South orientation (Northern hemisphere)**

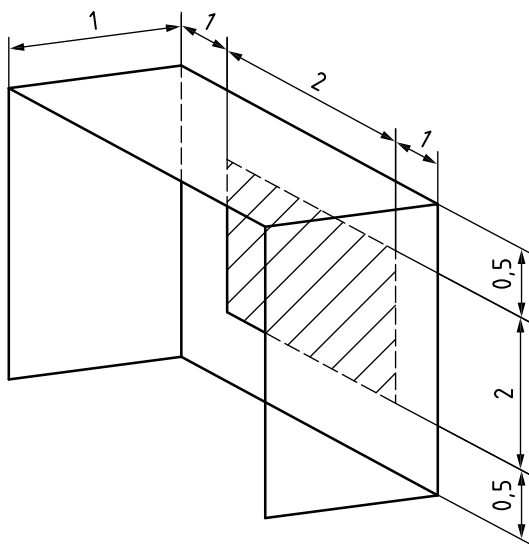

**c) Test No. 3: South orientation (Northern hemisphere)**

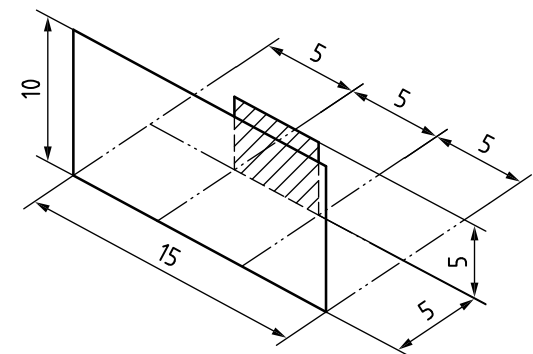

**d) Test No. 4: South orientation (Northern hemisphere)**

**Figure 10 (continued)**

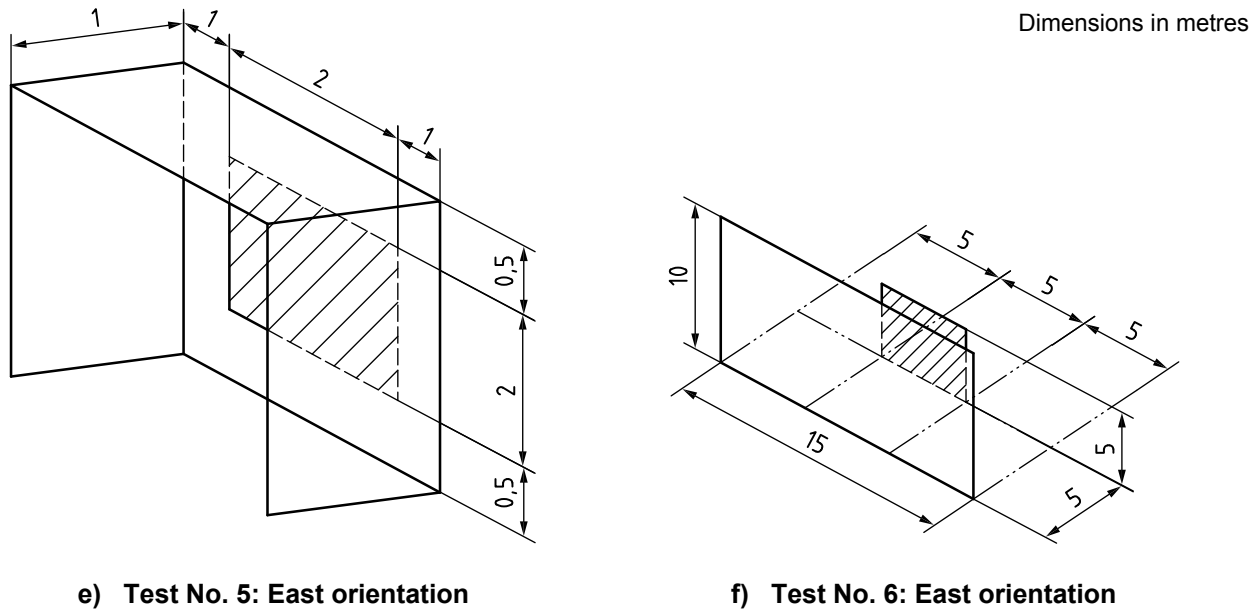

Figure 10 — Sunlit area

The hourly solar angles to be used for the tests are determined every 30 min and reported in Table 11.

Table 11 — Hourly solar angles

Hour	Solar altitude angle degrees	Solar azimuth angle degrees	Hour	Solar altitude angle degrees	Solar azimuth angle degrees
4:30	2,9	120,6	8:30	40,16	74,97
5:00	7,25	115,06	9:00	44,73	67,82
5:30	11,70	109,61	9:30	49,05	59,80
6:00	16,31	104,22	10:00	53,02	50,64
6:30	21,04	98,79	10:30	56,4	40,10
7:00	25,83	93,26	11:00	59,15	28,01
7:30	30,65	87,54	11:30	60,91	14,46
8:00	35,44	81,49	12:00	61,51	0,0

The solar azimuth angle of Table 11 is eastwards from south (Northern hemisphere), i.e. 0° at south, positive to the east and negative to the west.

For each test, the sunlit factor  $f_s$  shall be determined at the following times:

7:00 a.m.; 7:30 a.m.; 8:00 a.m.; 8:30 a.m.; 9:00 a.m.; 9:30 a.m.; 10:00 a.m.; 10:30 a.m.; 11:00 a.m.; 11:30 a.m.; 12:00 noon.

The validation requires to check the values of the sunlit factor at each hour or at each half hour according to the characteristics of the solution model adopted. Each value of  $f_s$  shall not differ from those in Table 12 by more than 0,05. Negative values are not consistent.

Table 12 — Value of the sunlit factor,  $f_s$ , for various cases

Hour	Test No. 1	Test No. 2	Test No. 3	Test No. 4	Test No. 5	Test No. 6
7:00	0,00	0,00	0,00	0,00	1,00	0,00
7:30	0,66	0,34	0,00	1,00	0,95	0,00
8:00	0,53	0,47	0,00	1,00	0,89	0,00
8:30	0,38	0,62	0,00	1,00	0,81	0,00
9:00	0,24	0,76	0,00	1,00	0,71	0,07
9:30	0,19	0,88	0,07	1,00	0,58	0,33
10:00	0,21	0,97	0,18	1,00	0,39	0,72
10:30	0,26	1,00	0,26	0,97	0,07	1,00
11:00	0,30	1,00	0,30	0,90	0,00	1,00
11:30	0,32	1,00	0,32	0,86	0,00	1,00
12:00	0,33	1,00	0,33	0,84	0,00	1,00

### 8.3 Validation procedure for the whole calculation method

#### 8.3.1 General

Whole model validation considers the calculation of the operative temperature under cyclic conditions for several cases indicated below, and the comparisons of these values with those included in Table 24 and Table 25. According to the assumptions of 4.1, the operative temperature is calculated as the average of the internal air temperature and the mean radiant temperature. According to the assumptions of this International Standard, the operative temperature is calculated as the average of the internal air temperature  $\theta_{a,i}$  and the mean radiant temperature  $\theta_{mr}$  of the internal surface of the room elements, calculated in Equation (33) as:

$$\theta_{mr} = \frac{\sum_{j=1}^N (\theta_{s,i} A_j)}{\sum_{j=1}^N A_j} \quad (33)$$

where

$N$  is the number of surfaces delimiting the internal space;

$\theta_{s,i}$  is the internal surface temperature;

$A_j$  is the area of surface  $j$ .

The geometrical characteristics of the rooms are given in Table 13.

Table 13 — Room data

Component	Geometry A	Geometry B
Area (m <sup>2</sup> ):		
External opaque wall	6,58	3,08
Window	3,50	7,00
Partition wall (left)	15,40	15,40
(right)	15,40	15,40
(back)	10,08	10,08
Floor	19,80	19,80
Ceiling	19,80	19,80
Volume (m <sup>3</sup> )	55,44	55,44

For determining the thermal capacity of the internal air, the following parameters are used:

- specific heat capacity of air: 1 008 J/(kg·K);
- air density: 1,139 kg/m<sup>3</sup>.

**8.3.2 Geometry for the test rooms**

The various test cases refer to two different geometries (Figure 11 and Figure 12) located in two zones with three different types of envelope and ventilation.

Dimensions in metres, unless otherwise specified

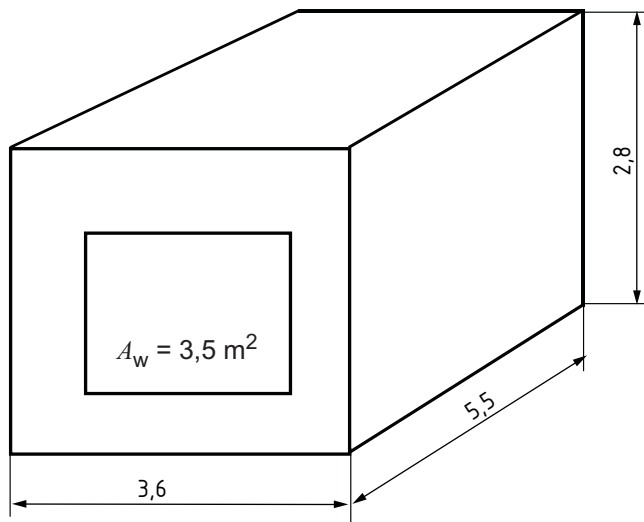

Figure 11 — Geometry A

Dimensions in metres,  
unless otherwise specified

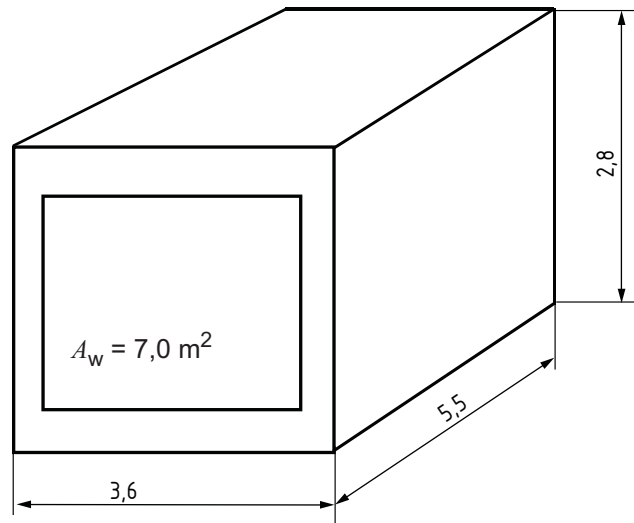

Figure 12 — Geometry B

### 8.3.3 Thermophysical properties of opaque walls

The thermophysical characteristics of the walls, ceiling and floor are given in Table 14.

### 8.3.4 Properties of glazing

The solar characteristics of the glass panes composing the glazing panes and the external shade are given in Table 15. This table shall be used for computer programs that need these data to calculate the values in Figure 13 and Figure 14.

Window specifications are given in Figures 13 and 14; the thermal resistance of window pane glass is assumed to be zero.

Table 14 — Thermophysical properties of the opaque components

Structure	$d$ m	$\lambda$ W/(m·K)	$\rho$ kg/m <sup>3</sup>	$c$ kJ/(kg·K)
<b>Type No. 1 (external wall)</b>				
Outer layer	0,115	0,99	1 800	0,85
Insulating layer	0,06	0,04	30	0,85
Masonry	0,175	0,79	1 600	0,85
Internal plastering	0,015	0,70	1 400	0,85
<b>Type No. 2 (internal wall)</b>				
Gypsum plaster	0,012	0,21	900	0,85
Insulating layer	0,10	0,04	30	0,85
Gypsum plaster	0,012	0,21	900	0,85
<b>Type No. 3 (ceiling/floor)</b>				
Plastic covering	0,004	0,23	1 500	1,5
Cement floor	0,06	1,40	2 000	0,85
Insulating layer	0,04	0,04	50	0,85
Concrete	0,18	2,10	2 400	0,85
<b>Type No. 4 (ceiling/floor)</b>				
Plastic covering	0,004	0,23	1 500	1,5
Cement floor	0,06	1,40	2 000	0,85
Insulating layer	0,04	0,04	50	0,85
Concrete	0,18	2,10	2 400	0,85
Insulating layer	0,10	0,04	50	0,85
Acoustic board	0,02	0,06	400	0,84
<b>Type No. 5 (roof)</b>				
External layer	0,004	0,23	1 500	1,3
Insulating layer	0,08	0,04	50	0,85
Concrete	0,20	2,1	2 400	0,85

Table 15 — Solar characteristics of the glazed element and the shade for all incident angles

Component	$\tau_n$	$\rho_n$
Pane	0,84	0,08
Shade	0,2	0,50



External, cavity and internal thermal resistances

$$R_{se} = 0,074 \text{ m}^2 \text{ K/W}$$

$$R_{cav} = 0,08 \text{ m}^2 \text{ K/W}$$

$$R_{si} = 0,125 \text{ m}^2 \text{ K/W}$$

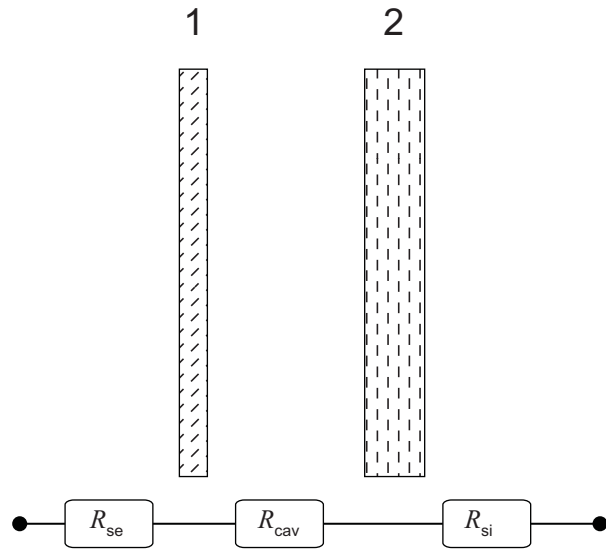

**Key**

- 1 external shade (or blind)
- 2 pane

**Figure 13 — Single pane window**

External, cavity and internal thermal resistances

$$R_{se} = 0,074 \text{ m}^2 \text{ K/W}$$

$$R_{ec} = 0,080 \text{ m}^2 \text{ K/W}$$

$$R_{ic} = 0,173 \text{ m}^2 \text{ K/W}$$

$$R_{si} = 0,125 \text{ m}^2 \text{ K/W}$$

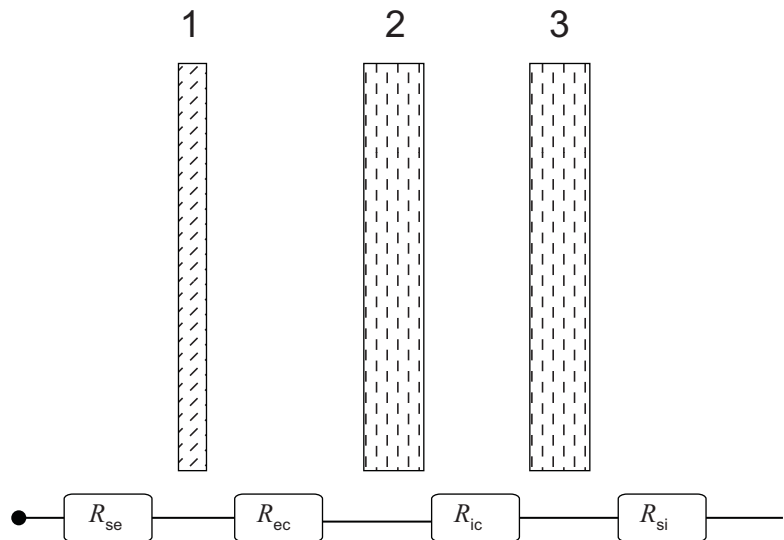

**Key**

- 1 external shade (or blind)
- 2 external pane
- 3 internal pane

**Figure 14 — Double pane glazing with external shading device**

**8.3.5 Solar parameters**

The solar parameters to be used are the following:

- solar to air factor,  $f_{sa} = 0,10$ ;
- solar loss factor,  $f_{sl} = 0,00$ ;

- solar distribution factor:
  - floor,  $f_d = 0,5$ ;
  - ceiling,  $f_d = 0,1$ ;
- total vertical walls (excluding windows),  $f_d = 0,4$ ;
- ceiling,  $f_d = 0,1$ ;
- total vertical walls (excluding window),  $f_d = 0,4$ ;
- solar absorptance of all wall surfaces,  $\alpha_{sr} = 0,6$ ;
- solar absorptance of the roof,  $\alpha_{sr} = 0,9$ .

### 8.3.6 Boundary conditions

External convective heat transfer coefficient,  $h_{c,e} = 8,0 \text{ W}/(\text{m}^2\cdot\text{K})$ .

Internal convective heat transfer coefficient:

$h_{c,i} = 2,5 \text{ W}/(\text{m}^2\cdot\text{K})$  (horizontal heat flow);

$h_{c,i} = 5,0 \text{ W}/(\text{m}^2\cdot\text{K})$  (upward heat flow);

$h_{c,i} = 0,7 \text{ W}/(\text{m}^2\cdot\text{K})$  (downward heat flow).

Radiative heat transfer coefficient,  $h_{lr} = 5,5 \text{ W}/(\text{m}^2\cdot\text{K})$  (all surfaces).

(valid for  $\varepsilon = 0,93$  and  $T_{mr} = 303 \text{ K}$ )

The climatic data are given:

- solar radiation:
  - Table 16 — Latitude 40° N is for Geometry A;
  - Table 17 — Latitude 52° N is for Geometry B;
- external air temperature:
  - Table 18 and Figure 15 for Geometry A;
  - Table 19 and Figure 16 for Geometry B.

Table 16 — Solar radiation components for Geometry A

Hour	Latitude 40° N					
	Horizontal			Vertical west		
	direct W/m <sup>2</sup>	diffuse W/m <sup>2</sup>	reflected W/m <sup>2</sup>	direct W/m <sup>2</sup>	diffuse W/m <sup>2</sup>	reflected W/m <sup>2</sup>
4	0	0	0	0	0	0
5	1	3	0	0	2	0
6	106	62	0	0	45	17
7	278	91	0	0	78	37
8	452	105	0	0	103	56
9	606	112	0	0	122	72
10	725	117	0	0	137	84
11	801	119	0	0	145	92
12	827	120	0	0	160	95
13	801	119	0	209	172	92
14	725	117	0	396	180	84
15	606	112	0	539	181	72
16	452	105	0	616	172	56
17	278	91	0	595	146	37
18	106	62	0	418	93	17
19	1	3	0	17	3	0
20	0	0	0	0	0	0

Table 17 — Solar radiation components for Geometry B

Hour	Latitude 52° N					
	Horizontal			Vertical west		
	direct W/m <sup>2</sup>	diffuse W/m <sup>2</sup>	reflected W/m <sup>2</sup>	direct W/m <sup>2</sup>	diffuse W/m <sup>2</sup>	reflected W/m <sup>2</sup>
4	0	0	0	0	0	0
5	35	34	0	0	15	7
6	153	73	0	0	33	23
7	295	93	0	0	42	39
8	435	104	0	0	47	54
9	558	110	0	0	50	67
10	654	114	0	0	51	77
11	714	116	0	0	52	83
12	735	117	0	0	64	85
13	714	116	0	204	78	83
14	654	114	0	387	94	77
15	558	110	0	529	107	67
16	435	104	0	609	115	54
17	295	93	0	606	111	39
18	153	73	0	492	89	23
19	35	34	0	223	41	7
20	0	0	0	0	0	0

**Table 18 — External air temperature for Geometry A**

Hour	$\theta_{ao}$ °C	Hour	$\theta_{ao}$ °C	Hour	$\theta_{ao}$ °C	Hour	$\theta_{ao}$ °C
1	23,6	7	22,8	13	32,7	19	29,9
2	23,0	8	23,9	14	33,6	20	28,4
3	22,5	9	25,8	15	34,0	21	27,0
4	22,1	10	27,3	16	33,6	22	25,8
5	22,0	11	29,3	17	32,8	23	24,9
6	22,2	12	31,2	18	31,5	24	24,2

**Table 19 — External air temperature for Geometry B**

Hour	$\theta_{ao}$ °C	Hour	$\theta_{ao}$ °C	Hour	$\theta_{ao}$ °C	Hour	$\theta_{ao}$ °C
1	14,1	7	13,1	13	26,2	19	22,6
2	13,3	8	14,6	14	27,5	20	20,5
3	12,6	9	16,6	15	28,0	21	18,7
4	12,2	10	19,0	16	27,5	22	17,1
5	12,0	11	21,8	17	26,4	23	15,8
6	12,3	12	24,3	18	24,6	24	14,9

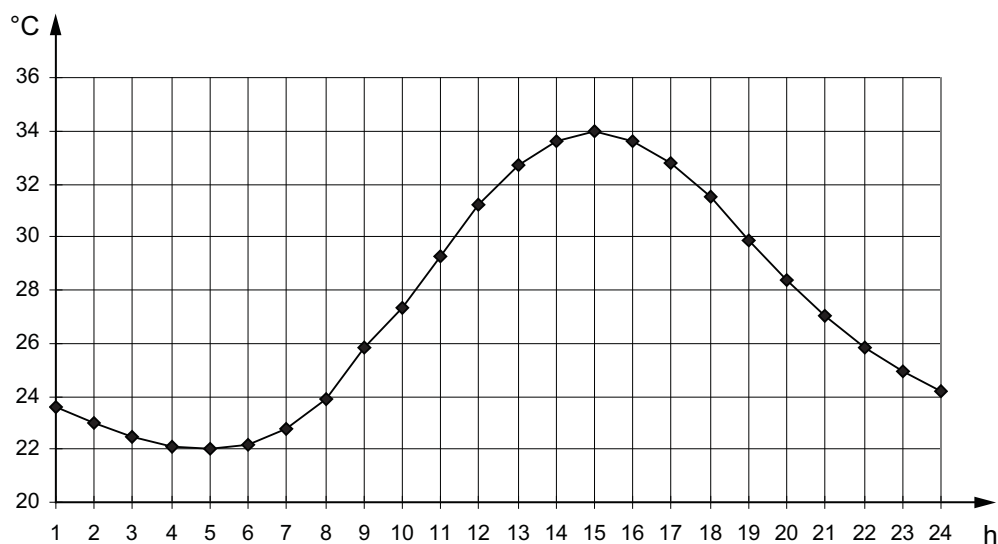

**Figure 15 — External air temperature for latitude 40°, in °C**

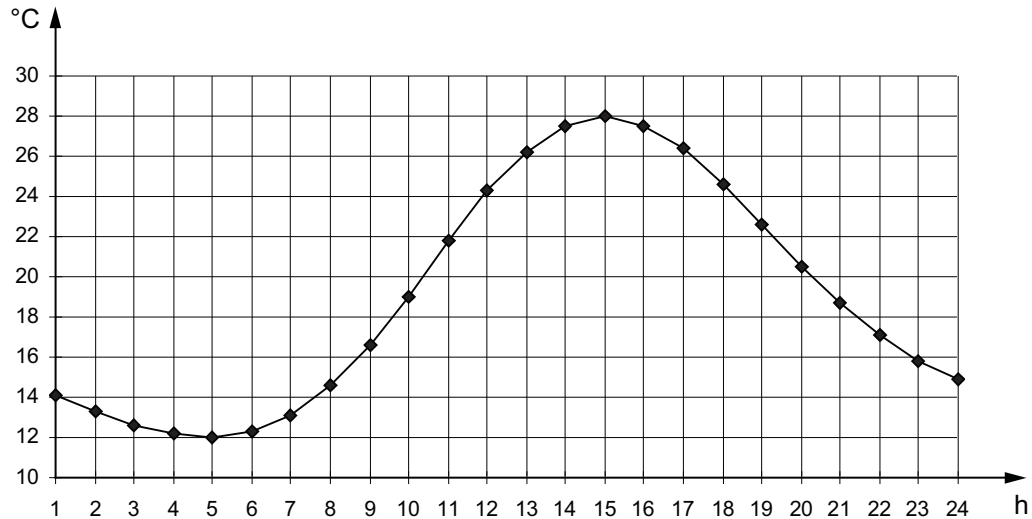

Figure 16 — External air temperature for latitude 52°, in °C

The values of the temperatures and solar radiation reported in the previous tables correspond to instantaneous values at each hour. If time intervals less than one hour are considered, the solar radiation at each time step shall be determined by linear interpolation between the previous and subsequent hour (see the example in Figure 17).

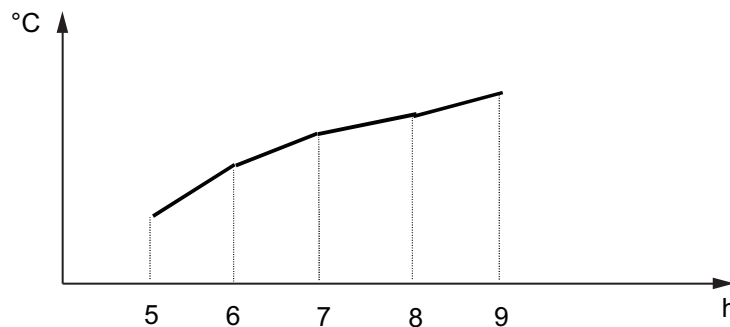

Figure 17 — Example of interpolation

### 8.3.7 Internal energy sources

The total heat flow rate due to internal sources expressed in watts per square metre of floor area is given in Table 20 and in Figure 18. The heat flow is transferred to the room by convection and radiation in equal proportions (50 % for each).

Table 20 — Total heat flow rate due to internal sources per floor area

Hour	$\Phi_i$ W/m <sup>2</sup>	Hour	$\Phi_i$ W/m <sup>2</sup>	Hour	$\Phi_i$ W/m <sup>2</sup>	Hour	$\Phi_i$ W/m <sup>2</sup>
0 to 1	0	6 to 7	0	12 to 13	10	18 to 19	15
1 to 2	0	7 to 8	1	13 to 14	10	19 to 20	15
2 to 3	0	8 to 9	1	14 to 15	10	20 to 21	15
3 to 4	0	9 to 10	1	15 to 16	1	21 to 22	15
4 to 5	0	10 to 11	1	16 to 17	1	22 to 23	10
5 to 6	0	11 to 12	10	17 to 18	1	23 to 24	0

The daily total value of the internal gains is 117 Wh/m<sup>2</sup>.

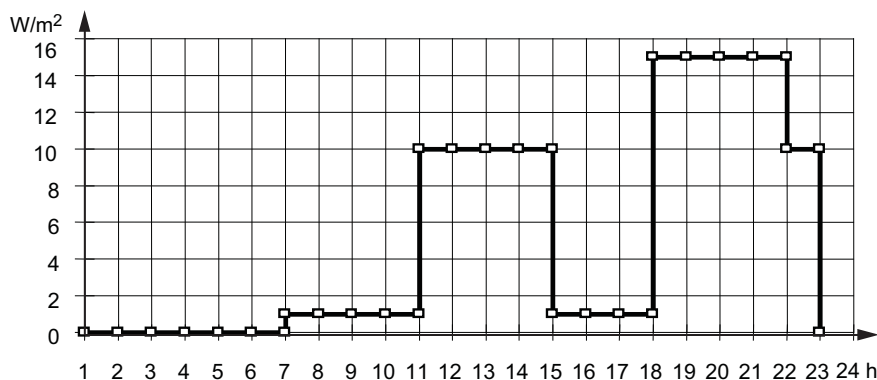

Figure 18 — Internal gains

### 8.3.8 Ventilation

Three different ventilation patterns are considered (Table 21):

- a) air changes/h equal to 1 h<sup>-1</sup>, constant;
- b) air changes/h equal to 0,5 h<sup>-1</sup>, constant from 6:00 to 18:00 (inclusive) — other hours air changes/h equal to 10 h<sup>-1</sup>, constant;
- c) air changes/h equal to 10 h<sup>-1</sup>, constant.

Table 21 — Air changes per hour

Hour	a	b	c	Hour	a	b	c
0 to 1	1	10	10	12 to 13	1	0,5	10
1 to 2	1	10	10	13 to 14	1	0,5	10
2 to 3	1	10	10	14 to 15	1	0,5	10
3 to 4	1	10	10	15 to 16	1	0,5	10
4 to 5	1	10	10	16 to 17	1	0,5	10
5 to 6	1	10	10	17 to 18	1	0,5	10
6 to 7	1	0,5	10	18 to 19	1	10	10
7 to 8	1	0,5	10	19 to 20	1	10	10
8 to 9	1	0,5	10	20 to 21	1	10	10
9 to 10	1	0,5	10	21 to 22	1	10	10
10 to 11	1	0,5	10	22 to 23	1	10	10
11 to 12	1	0,5	10	23 to 24	1	10	10

### 8.3.9 Descriptions of the validation tests

#### 8.3.9.1 General

The following tests are considered.

For geometry A (see Figure 11), three tests shall be carried out as shown in Table 22, where the types of elements are identified by the numbers used in Table 14 and the letters used in Figure 13.

Single pane glazing with external shade completely closed exposed to west.

Area of external opaque wall is 6,58 m<sup>2</sup>.

Area of window is 3,50 m<sup>2</sup>.

**Table 22 — Test cases A**

Test No.	External opaque wall	Glazing	Partition vertical wall to similar room	Ceiling to similar room	Floor to similar room	Roof
A.1	1	Single	2	4	4	—
A.2	1	Single	2	3	3	—
A.3	1	Single	2	—	3	5

For geometry B (see Figure 12), three tests shall be carried out as shown in Table 23, where the types of elements are identified by the numbers used in Table 13 and the letters used in Figure 15.

Double pane glazing with external shade completely closed exposed to west.

Area of external opaque wall is 3,08 m<sup>2</sup>.

Area of window is 7,00 m<sup>2</sup>.

**Table 23 — Test cases B**

Test No.	External opaque wall	Glazing	Partition vertical wall to similar room	Ceiling to similar room	Floor to similar room	Roof
B.1	1	Double	2	4	4	—
B.2	1	Double	2	3	3	—
B.3	1	Double	2	—	3	5

### 8.3.9.2 Results of validations

For each test the following data, determined in cyclic conditions, shall be calculated:

- daily maximum value of the operative temperature,  $\theta_{op,max}$ ;
- daily average value of the operative temperature,  $\theta_{op,av}$ ;
- daily minimum value of the operative temperature,  $\theta_{op,min}$ .

For each case the comparison with the values reported in Table 24 for geometry A and Table 25 for geometry B, shall give a difference of less than 0,5 K.

**Table 24 — Operative temperature for geometry A**

Test	Ventilation	$\theta_{op,max}$ °C	$\theta_{op,ave}$ °C	$\theta_{op,min}$ °C
	a)	40,0	37,2	34,8
A.1	b)	33,6	29,5	25,5
	c)	33,8	29,3	25,6
	a)	38,8	37,2	35,6
A.2	b)	32,8	30,0	26,8
	c)	32,6	29,4	26,6
	a)	41,7	39,7	37,9
A.3	b)	35,7	32,0	28,1
	c)	34,0	30,5	27,5

**Table 25 — Operative temperature for geometry B**

Test	Ventilation	$\theta_{op,max}$ °C	$\theta_{op,ave}$ °C	$\theta_{op,min}$ °C
	a)	35,8	30,5	27,1
B.1	b)	29,9	22,1	16,4
	c)	28,1	21,5	16,2
	a)	33,7	30,8	28,5
B.2	b)	26,7	22,2	17,9
	c)	26,4	21,7	17,7
	a)	36,0	32,7	30,3
B.3	b)	29,6	24,2	19,2
	c)	27,7	22,7	18,6

NOTE More detailed information is given in Annex J.



## Annex A (informative)

### Example of solution technique

#### A.1 Introduction

This annex gives a numerical method for the calculation of the internal temperature of a room in the absence of any cooling plant based on an implicit empirical technique.

#### A.2 Basic assumptions for the calculation method

The method is based on the assumptions given in 4.1 of this International Standard. Further assumptions on the physical phenomena and on the solution techniques, in order to obtain a simpler energy balance, are introduced. They are:

- energy flows by long-wave radiation to/from each surface are calculated by reference to the effective mean radiant temperatures of the other surfaces, the latter being calculated by area-weighting. The fictitious Mean Radiant Temperature Node is considered as the central node of the network of all long-wave radiative heat transfers;
- the air temperature difference influencing the air flow by infiltration and/or ventilation is assumed to be constant during the time interval.

#### A.3 Calculation procedure

##### A.3.1 General

The method operates as follows:

- a) it subdivides the system into nodes placed at pre-selected points of interest throughout the system to be simulated;
- b) for each node in turn and in terms of all surrounding nodes which are in thermal contact, the governing differential equation is replaced by an implicit numerical approximation, based on the fact that half the sum of the net heat flow rate at the start and finish of any finite time increment is equated with the total rate of change in internal energy in the region represented by the node in question;
- c) the resulting set of equations (one for each node) is solved simultaneously at each time step.

##### A.3.2 Evaluation of the temperature of each enclosure component

###### A.3.2.1 General

According to Clause 4 sets of equations are written for all nodes characterizing the component. For an opaque wall, in which thermal storage effects occur, a subdivision according to the finite difference technique is introduced. To achieve more accurate computations, homogeneous elements can be subdivided and specified in parts. For transparent components, in which thermal storage effects can be neglected, nodes are chosen according to the characteristics of the component.

For each node (from  $n = 1$ , at the external surface, to  $n = N$ , at the internal surface) the equation, deriving from the thermal balance at time  $t + \Delta t$ , is written in the general form as in Equation (A.1):

$$K_{1,n}\theta_{n-1,t+\Delta t} + K_{2,n}\theta_{n,t+\Delta t} + K_{3,n}\theta_{n+1,t+\Delta t} = D_n \quad (\text{A.1})$$

where factors  $K$  depend on the characteristics of the element, and  $D$  depends on the state of the system. The temperature of node  $n$  at time  $t + \Delta t$  is calculated in Equations (A.2) and (A.3) as:

$$\theta_{N,t+\Delta t} = C_N \quad (\text{A.2})$$

$$\theta_{n,t+\Delta t} = C_n - \frac{K_{3,n}\theta_{n+1,t+\Delta t}}{B_n} \quad (\text{A.3})$$

where the coefficients  $C_n$  ( $n = 1, N$ ),  $B_n$  ( $n = 1, N$ ) and  $D_n$  ( $n = 1, N$ ) are determined in Equations (A.4) and (A.5) as follows:

$$B_n = K_{2,n} - \frac{K_{1,n}K_{3,n-1}}{B_{n-1}} \quad (\text{A.4})$$

with  $B_1 = K_{2,n}$

$$C_n = \frac{D_n - K_{1,n}C_{n-1}}{B_n} \quad (\text{A.5})$$

with  $C_1 = \frac{D_1}{K_{2,1}}$

The values  $B_n$  and  $C_n$  are determined with increasing subscript  $n$  for all nodes. The required temperature distribution is computed with decreasing subscript  $n$ . The nodes at the external surface ( $n = 1$ ) and the internal surface ( $n = N$ ) are included within the wall.

### A.3.2.2 Coefficients in Equation (A.1)

#### A.3.2.2.1 Opaque components

With respect to the conflicting requirements imposed by the considerations of good accuracy as well as high speed and low cost of computation, the subdivision of the component into different nodes should be carefully considered. Three nodes per element (layer), with one node placed at each boundary of the element and one at the centre plane, is the minimum nodal representation. To achieve more accurate computations, homogeneous elements can be divided into more parts as follows:

- 1) limit the distance between two subsequent nodes ( $\Delta x$ ) as a function of the thermal conductivity of the layer:

$$\text{if } \lambda < 0,5 \text{ W/(m}\cdot\text{K)} \quad \Delta x_{\text{max}} = 0,02 \text{ m;}$$

$$\text{if } \lambda > 0,5 \text{ W/(m}\cdot\text{K)} \quad \Delta x_{\text{max}} = 0,03 \text{ m;}$$

- 2) the time increment  $\Delta t$  is determined as:  $\Delta t = \Delta x^2/(2a)$

where  $a = \lambda/(\rho c)$  is the thermal diffusivity, in  $\text{m}^2/\text{s}$ ;

- 3) for multilayered constructions, the distance between two subsequent nodes should be calculated for each layer separately. The time increment to be used for the calculation corresponds to the maximum calculated for each layer.

**NOTE** This nodal representation scheme implies that multilayered construction nodes situated at the boundary between different homogeneous elements represent mixed thermal property regions. Furthermore, the internal and external surface nodes, which represent convective, radiative and conductive heat exchanges, have associated thermal capacities equal to one half of the surface layer capacity.

For each node type of interest the factors  $K$  and  $D$  are derived in the following equations as follows:

**a) Node at the centre of homogeneous elements**

$$K_{1,n} = -F_n \quad K_{2,n} = 2(1 + F_n) \quad K_{3,n} = -F_n \quad (\text{A.6})$$

$$D_n = F_n \theta_{n-1,t} + 2(1 - F_n) \theta_{n,t} - F_n \theta_{n+1,t} + B_n (q_{n,t+\Delta t} + q_{n,t}) \quad (\text{A.7})$$

with

$$F_n = \frac{\lambda_n \Delta t}{\rho_n c_n \Delta x^2} \quad (\text{A.8})$$

$$B_n = \frac{\Delta t}{\rho_n c_n \Delta x_n}$$

where

$\Delta t$  is the time increment;

$c$  is the specific heat of the region;

$\Delta x$  is the thickness of the region represented by node  $n$ ;

$\lambda$  is the thermal conductivity of the element;

$\rho$  is the density of the element;

$q$  is the density of heat flow rate generated within the region.

**b) Node situated at the boundary between two different homogeneous elements**

$$K_{1,n} = -F_{n-1} \quad K_{2,n} = (2 + F_{n-1} + F_{n+1}) \quad K_{3,n} = -F_{n+1} \quad (\text{A.9})$$

$$D_n = F_{n-1} \theta_{n-1,t} + (2 - F_{n-1} - F_{n+1}) \theta_{n,t} + F_{n+1} \theta_{n+1,t} + B_n (q_{n,t+\Delta t} + q_{n,t}) \quad (\text{A.10})$$

where suffices  $n - 1$  and  $n + 1$  refer to the homogeneous elements on either side of boundary node  $n$ .

$$F_{n-1} = \frac{\lambda_{n-1}\Delta t}{\Delta x_{n-1} \left[ \left( \frac{\rho c \Delta x}{2} \right)_{n-1} + \left( \frac{\rho c \Delta x}{2} \right)_{n+1} \right]} \quad (\text{A.11})$$

$$F_{n+1} = \frac{\lambda_{n+1}\Delta t}{\Delta x_{n+1} \left[ \left( \frac{\rho c \Delta x}{2} \right)_{n-1} + \left( \frac{\rho c \Delta x}{2} \right)_{n+1} \right]}$$

$$B_n = \frac{\Delta t}{\Delta x_{n+1} \left[ \left( \frac{\rho c \Delta x}{2} \right)_{n-1} + \left( \frac{\rho c \Delta x}{2} \right)_{n+1} \right]} \quad (\text{A.12})$$

**c) Node situated at the boundary between a homogeneous element and an air layer**

The node  $n - 1$  is on the opposite side of the air layer.

$$K_{1,n} = -F_a \quad K_{2,n} = \left( \frac{3}{4} + F_a + F_n \right) \quad K_{3,n} = \frac{1}{4} - F_a \quad (\text{A.13})$$

$$D_n = F_a \theta_{n-1,t} + \left( \frac{3}{4} - F_a - F_n \right) \theta_{1,t} + \left( \frac{1}{4} + F_n \right) \theta_{n,t} + B_n (q_{n,t+\Delta t} + q_{n,t}) \quad (\text{A.14})$$

with

$$F_a = \frac{(A_a + A_{lr})\Delta t}{\rho_n c_n \Delta x} \quad F_n = \frac{2\lambda_n \Delta t}{\rho_n c_n \Delta x^2} \quad B_n = \frac{2h_t \Delta t}{\rho_n c_n \Delta x_n} \quad (\text{A.15})$$

where

$\Delta x$  is the distance between two subsequent nodes;

$A_{lr}$  is the long-wave radiative conductance of the cavity;

$A_a$  is the air conductance.

Subscript l refers to air layer.

In Equation (A.15) the air conductance is determined by using the values of Table 3 or Table 4 or for an unventilated air cavity, or by  $q_{c,n}/(\theta_{n-1} - \theta_n)$  (see Annex B) for a ventilated air cavity; the radiative conductance of the cavity is calculated according to 4.5.4.3, Equation (29).

**d) Node at the external surfaces of a room element ( $n = 1$ )**

$$K_{1,1} = 0 \quad K_{2,1} = \frac{3}{4} + F_1 + F_e \quad K_{3,1} = \frac{1}{4} - F_1 \quad (\text{A.16})$$

$$D_1 = \left( \frac{3}{4} - F_e - F_1 \right) \theta_{1,t} + F_e (\theta_{ae,t+\Delta t} + \theta_{ae,t}) + \left( \frac{1}{4} + F_1 \right) \theta_{2,t} + B_1 (q_{1,t+\Delta t} + q_{1,t}) \quad (\text{A.17})$$

with  $F_e = \frac{h_{c,e} \Delta t}{\rho_1 c_1 \Delta x_1}$  and  $q_1 = q_{sr,e} - q_{lr,e}$

where

$\theta_{ae}$  is the air temperature of the adjacent space;

$h_{c,e}$  is the external convective surface coefficient of heat transfer [see Equation (14)];

$q_{sr,e}$  is the density of total solar heat flow rate absorbed at the external surface;

$q_{lr,e}$  is the density of net long-wave radiant heat flow rate at the external surface.

**e) Node at the internal surfaces of a room element ( $n = N$ )**

$$K_{1,N} = \frac{1}{4} - F_N \quad K_{2,N} = \left( \frac{3}{4} + F_N + F_i \right) \quad K_{3,N} = 0 \quad (\text{A.18})$$

$$D_N = \left( \frac{1}{4} + F_N \right) \theta_{N-1,t} + \left( \frac{3}{4} - F_e - F_N \right) \theta_{N,t} + F_e (\theta_{ai,t+\Delta t} + \theta_{ai,t}) + B_N (q_{N,t+\Delta t} + q_{N,t}) \quad (\text{A.19})$$

with  $F_e = \frac{h_{c,i} \Delta t}{\rho_N c_N \Delta x_N}$  and  $q_N = q_{lr,i} - q_{sr,i}$

where

$\theta_{a,i}$  is the room air temperature;

$h_{c,i}$  is the internal convective surface coefficient of heat transfer (see Table 1);

$q_{lr,i}$  is the density of net heat flow rate due to long-wave radiation received by the internal surface (see Annex E);

$q_{sr,i}$  is the density of heat flow rate due to short-wave radiation absorbed by the internal surface [see Equation (19)].

**A.3.2.2.2 Transparent components**

The following equations refer to a transparent component formed by a double pane of glass. In this component, neglecting the thickness of each glass pane, the following nodes are present:

- node at the external pane (external surface);
- node at the internal pane (internal surface);
- node in the air cavity between the panes.

This situation can be extended to consider internal and external blinds. One single pane without any blind can be considered by assuming the value of the heat transfer coefficient between each pane to be very high.

**a) Node ( $n = 1$ ) located at the external surface**

$$K_{1,1} = 0 \quad K_{2,1} = h_{c,e} + A_t \quad K_{3,1} = -A_t \quad (\text{A.20})$$

$$D_1 = h_{c,e} \theta_{e,t+\Delta t} + (q_{sr,e} - q_{er})_{t+\Delta t} \quad (\text{A.21})$$

**b) Node ( $n = N$ ) located at the internal surface**

$$K_{1,N} = -A_t \quad K_{2,N} = h_{c,i} + A_t \quad K_{3,N} = 0 \quad (\text{A.22})$$

$$D_N = h_{c,i} \theta_{a,t+1} + (q_{lr,i} - q_{sr,i})_{t+1} \quad (\text{A.23})$$

where

$h_{c,e}$  is the external convective heat transfer coefficient [from Equation (13)];

$h_{c,i}$  is the internal convective heat transfer coefficient (from Table 1);

$A_t$  is the sum of the gas conductance and the radiative conductance of the cavity;

$q_{sr}$  is the density of the short-wave radiant heat flow absorbed by the surface;

$q_{lr}$  is the density of the long-wave radiant heat flow absorbed by the surface.

**c) Node  $n$  located between two air layers**

$$K_{1,n} = -A_{t,n-1} \quad K_{2,n} = A_{t,n+1} + A_{t,n-1} \quad K_{3,n} = -A_{t,n+1} \quad (\text{A.24})$$

$$D_n = q_{n,t+\Delta t} \quad (\text{A.25})$$

where

$A_t$  is the sum of the air conductance and the long-wave radiative conductance  $A$ ;

$q_n$  is the density of the radiant heat flow absorbed by the surface.

**A.3.2.3 Air temperature**

The air temperature is determined by solving the following equation:

$$\sum_{j=1}^N K_{1,j} \theta_{N,t+\Delta t,j} + K_{2,a} \theta_{a,t+\Delta t} = D_a \quad (\text{A.26})$$

with

$$K_{2,a} = 2 + \frac{\left[ \sum_{j=1}^N (h_{c,i,j} A_j) + (c_a m_{a,n} + c_a m_{a,m}) \right]}{C_a}$$

$$D_a = \frac{\left[ \sum_{j=1}^N (h_{c,i,j} A_j \theta_{N,j}) + (\Phi_{a,t+\Delta t} + \Phi_{a,t}) \right]}{C_{a,j}}$$

$$+ \left[ 2 - \frac{\sum_{j=1}^N (h_{c,i,j} A_j) + c_a m_{a,n} + c_a m_{a,m}}{C_{a,j}} \right] \theta_{a,i,t} \quad (\text{A.27})$$

$$+ \left[ c_a m_{a,n} (\theta_{ae,t+\Delta t} + \theta_{ae,t}) + c_a m_{a,m} \frac{(\theta_{v,t+\Delta t} + \theta_{v,t})}{C_{a,j}} \right]$$

where

$N$  is the number of enclosure surfaces;

$h_{c,i,j}$  is the convection coefficient at each internal surface  $j$ ;

$A$  is the area of each surface at each internal surface  $j$ ;

$m_{a,n}$  is the mass air flow rate by natural ventilation;

$m_{a,m}$  is the mass forced air flow rate by mechanical ventilation;

$c_a$  is the specific heat capacity of the air;

$\theta_{a,e}$  is the external air temperature;

$\theta_{a,i}$  is the internal air temperature;

$\theta_v$  is the temperature of the mechanically supplied air;

$$C_a = \frac{\rho_a c_a V}{\Delta t} \quad (\text{A.28})$$

where

$\rho_a$  is the density of air;

$V$  is the enclosure volume;

$\Delta t$  is the time increment.

The terms  $\Phi_a$  are summations of the convective energy exchanges with the enclosure air at any time  $t$  and  $t + \Delta t$ . In general form this is given by Equation (A.29):

$$\Phi_a = \Phi_{i,c} + \Phi_a + \Phi_{sa} \quad (\text{A.29})$$

where

$\Phi_{i,c}$  is the heat flow rate due to the convective component of internal gains;

$\Phi_a$  is the heat flow rate due to the air passing through internal air cavities;

$\Phi_{sa}$  is the heat flow rate due to the convective part of solar radiation flow entering through the window.

The heat flow rate due to the convective component of internal gains acting at the enclosure air point (room air) is given by Equation (A.30):

$$\Phi_{i,c} = \sum_{j=1}^m \Phi_{i,j} f_{i,c,j} \quad (\text{A.30})$$

where

$m$  is the number of different sources;

$\Phi_j$  is the heat flow rate due to each internal source  $j$ ;

$f_{i,c}$  is the fraction of the total heat flow rate due to each internal source  $j$ .

The data of internal gains in Annex H can be considered.

The mass air flow by natural ventilation can be calculated according to the procedure in Annex H.

The convective part of the short-wave radiation entering through the glazing system is given by Equation (A.31):

$$\Phi_{sa} = f_{sa}(1 - f_{sl})(\Phi_{sr,D} + \Phi_{sr,d}) \quad (\text{A.31})$$

#### A.4 Room thermal balance

Equation (A.1), written for all internal surfaces, with Equation (A.26) written for the internal air, are simultaneously solved. From the solution of the system equations, the internal surface temperature of each enclosure component and the internal air temperature are determined. The required temperature distribution within each component is determined by using Equation (A.2) with decreasing subscript  $n$ .



## Annex B (informative)

### Convective heat transfer through ventilated air layer

#### B.1 Introduction

The procedure presented in this annex allows the user to determine the convective heat transfer through a vertical and externally ventilated air layer. An example is the air gap between a glass pane and a curtain where openings are present around the curtain and the curtain itself may be partially permeable to the air flow.

#### B.2 Convective heat transfer for a vertical air layer

##### B.2.1 General

For a vertical ventilated air layer the convective heat transfer is:

- with the environment due to the air flow through the air cavity;
- with the boundary surfaces.

These require the evaluation of the air velocity within the cavity.

##### B.2.2 Evaluation of the outlet velocity of the vertical air layer

The mean velocity of the air in the space is principally caused by the stack effect. Convection caused by wind pressure is neglected.

The mean air velocity depends on the driving pressure difference,  $\Delta p_m$ , and on the total pressure loss in the ventilated air space itself (Figure B.1).

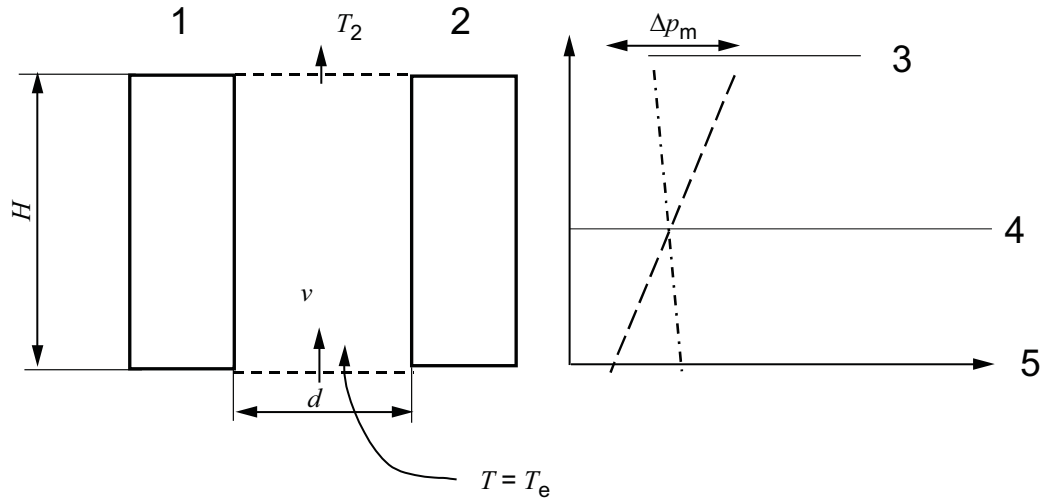

**Key**

- 1 layer  $n - 1$
- 2 layer  $n$
- 3 top
- 4 neutral plane
- 5 bottom

**Figure B.1 — Example of vertical air layer: the height of the neutral plane depends on the flow resistances of the inlet and outlet openings**

The driving pressure difference results from the temperature difference between the air layer and the air of the environment. It is written as:

$$\Delta p_m = \frac{\rho_{a,o} g T_0 H (T_{eq} - T_e)}{(T_{eq} - T_e)} \tag{B.1}$$

with

$$T_{eq} = T_{av} - E_r (T_{av} - T_e) (1 - e^{-1/E_r}) \tag{B.2}$$

$$T_{av} = \frac{(T_{n-1} + T_n)}{2} \tag{B.3}$$

$$E_r = \left( \frac{\rho_a c_a d}{2 h_a H} \right) v \tag{B.4}$$

$$h_a = 2 h_g + c_v v \tag{B.5}$$

where

- $\Delta p_m$  is the driving pressure difference, in Pa;
- $\rho_{a,o}$  is the density of the air at the temperature  $T_0$ , in  $kg/m^3$ ;
- $H$  is the height of the element, in m;
- $T_0$  is the reference temperature, in K;

- $T_{\text{eq}}$  is the equivalent temperature of the air in the layer, in K;
- $T_{\text{e}}$  is the temperature of the environment, external or internal air, in K;
- $T_{\text{av}}$  is the average of temperatures of the surfaces delimiting the air layer, in K;
- $T_{n-1}, T_n$  are the temperature of the layer  $n - 1$  and  $n$ ;
- $E_r$  is a ventilation parameter;
- $c_a$  is the specific heat of the air at the constant pressure, in J/(kg·K);
- $d$  is the width of the air layer between the delimiting surfaces, in m;
- $v$  is the mean velocity in the ventilated air layer, in m/s;
- $h_g$  is the convective heat transfer coefficient for closed spaces, in W/(m<sup>2</sup>·K);
- $c_v$  is the velocity coefficient, in W·s/(m<sup>3</sup>·K);
- $g$  is the acceleration due to gravity (constant) 9,81 m/s<sup>2</sup>.

The coefficient  $h_g$  can be calculated with Equation (B.6):

$$h_g = \left( \frac{\lambda_a (Ra)^n}{d} \right) \quad (\text{B.6})$$

where, for vertical spaces:  $A = 0,035$ ;  $n = 0,38$  and the Rayleigh number is shown in Equation (B.7):

$$Ra = \frac{g d^3 c_a \rho_a^2 |T_j - T_{j+1}|}{\mu_a \lambda_a T_{\text{av}}} \quad (\text{B.7})$$

where

- $\mu_a$  is the dynamic viscosity of the gas in the air layer, in kg/(m·s);
- $\lambda_a$  is the thermal conductivity of the gas in the air layer, in W/(m·K);
- $\rho_a$  is the density of the gas in the air layer.

The velocity coefficient  $c_v$  can be assumed equal to 4 W·s/(m<sup>3</sup>·K).

The total pressure loss  $\Delta p_T$  in the ventilated air layer is calculated in Equation (B.8) as:

$$\Delta p_T = \Delta p_v + \Delta p_d + \Delta p_{i0} \quad (\text{B.8})$$

where

- $\Delta p_v$  is the kinetic pressure loss, in Pa;
- $\Delta p_d$  is the pressure loss due to the steady laminar flow, in Pa;
- $\Delta p_{i0}$  is the pressure loss in the top and bottom openings, in Pa.

The terms in Equation (B.8) are given by:

$$\Delta p_v = \frac{1}{2} \rho_a v^2 \quad (\text{B.9})$$

$$\Delta p_d = 8 \mu_a \frac{H}{s^2} v \quad (\text{B.10})$$

$$\Delta p_{io} = \frac{1}{2} \rho_a v^2 (Z_1 + Z_2) \quad (\text{B.11})$$

where

- $\mu_a$  is the dynamic viscosity of the air, in kg/(m·s);
- $v$  is the velocity of the air within the cavity, in m/s;
- $H$  is the height of the cavity, in m;
- $d$  is the width of the cavity, in m;
- $Z_1, Z_2$  are parameters relevant for the top and bottom openings.

The parameters  $Z_1$  and  $Z_2$ , according to Figure B.2, are given by:

$$Z_1 = \left( \frac{A_s}{0,6 A'_1} - 1 \right)^2 \quad (\text{B.12})$$

$$Z_2 = \left( \frac{A_s}{0,6 A'_2} - 1 \right)^2 \quad (\text{B.13})$$

$$A'_1 = A_b + \frac{A_l + A_r + A_h}{4} \quad (\text{B.14})$$

$$A'_2 = A_t + \frac{A_l + A_r + A_h}{4} \quad (\text{B.15})$$

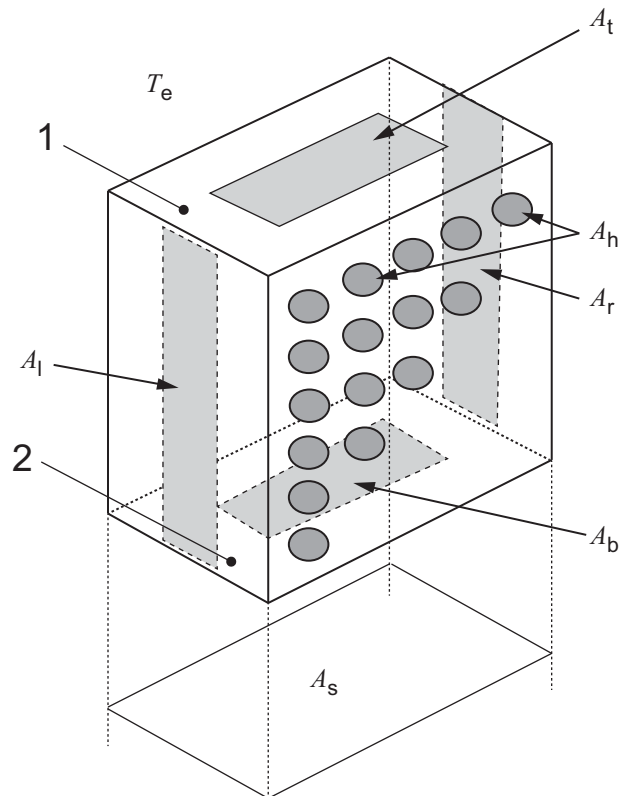

Key  
 1 top  
 2 bottom

Figure B.2 — Example of ventilated cavity

where

- $A_s$  the projected area of the considered system, in  $m^2$ ;
- $A_t$  area of the top opening, in  $m^2$ ;
- $A_b$  area of the bottom opening, in  $m^2$ ;
- $A_l$  area of the left side opening, in  $m^2$ ;
- $A_r$  area of the right side opening, in  $m^2$ ;
- $A_h$  total area of the homogeneous distributed holes in the blind (only one side), in  $m^2$ .

The velocity  $v$  in the ventilated air layer is obtained by solving Equation (B.16):

$$\Delta p_m = \Delta p_T \tag{B.16}$$

### B.2.3 Evaluation of the convective heat transfers for a vertical air layer

The convective heat flow rates  $\Phi$  are calculated in Equation (B.17) as:

— due to the air motion:

$$\Phi_v = m_v c_a (T_{out} - T_{in}) \tag{B.17}$$

where

- $m_v$  is the mass air flow through the air layer, in kg/s;
- $T_{out}$  is the temperature of the air leaving the layer, in K;
- $T_{in}$  is the temperature of the air entering the air layer, in K

with

$$q_a = r v A_a \quad (B.18)$$

where  $A_a$  is the area of the cross-section of the air flow.

$$T_{out} = T_{av} - (T_{av} - T_{eq}) e^{-1/E_r} \quad (B.19)$$

— due to the convective heat exchanges with the surfaces  $n - 1$  and  $n$  delimiting the air layer:

$$\Phi_{c,n-1} = h_c A_c (T_{n-1} - T_{eq}) \quad (B.20)$$

$$\Phi_{c,n} = h_c A_c (T_n - T_{eq}) \quad (B.21)$$

where  $A_c$  is the area of the adjacent surfaces.

### B.3 Convective heat transfer for an external horizontal air layer

#### B.3.1 General

A similar calculation for an external horizontal air layer is made (Figure B.3). In this case, the driving pressure difference  $\Delta p_w$  derives from the wind velocity in Equation (B.22) as follows:

$$\Delta p_w = \Delta C_{pr} \frac{1}{2} \rho v^2 \quad (B.22)$$

where

- $\Delta C_{pr}$  is the difference in the pressure coefficients between the inlet and the outlet of the air layer;
- $v$  is the wind velocity.

$\Delta C_{pr}$  assumes values changing from 0 (no openings perpendicular to the wind direction) to 1.

The total pressure losses  $\Delta p_T$  are calculated according to Equation (B.8). The velocity  $v$  in the ventilated air layer is obtained by solving Equation (B.23):

$$\Delta p_w = \Delta p_T \quad (B.23)$$

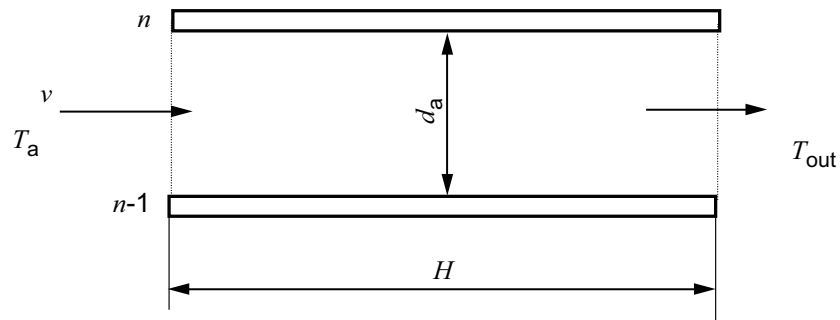

Figure B.3 — Example of horizontal air layer

### B.3.2 Evaluation of the convective heat transfer for horizontal air layer

The convection heat transfers are calculated as in B.2.3:

- due to the air motion  $\Phi_v$ , according to Equation (B.17);
- due to the convective heat exchanges with the surfaces  $n - 1$  and  $n$  delimiting the air layer,  $\Phi_c$ , according to Equation (B.20) and Equation (B.21).

## Annex C (informative)

### Shading due to overhangs and side fins

#### C.1 Introduction

This annex includes a procedure for determining the shaded area of a building element when obstructions due to an overhang and side fin are present.

The equations recognize wall solar azimuth angle  $\gamma$  and solar altitude  $\beta$  as known angles (Figure C.1). Other dimensions for a window of length  $L$  and height  $H$  are shown in Figure C.2 for an overhang and Figure C.3 for a side fin. Various shapes of shadows on a window are shown in Figure C.4. Shadows for an overhang, for an overhang with a vertical end projection, and for side fins, are separated to simplify the equations and their calculation procedure. After all types of shadows have been established, the procedure will then add up all the shadow areas for use in the final solar contribution.

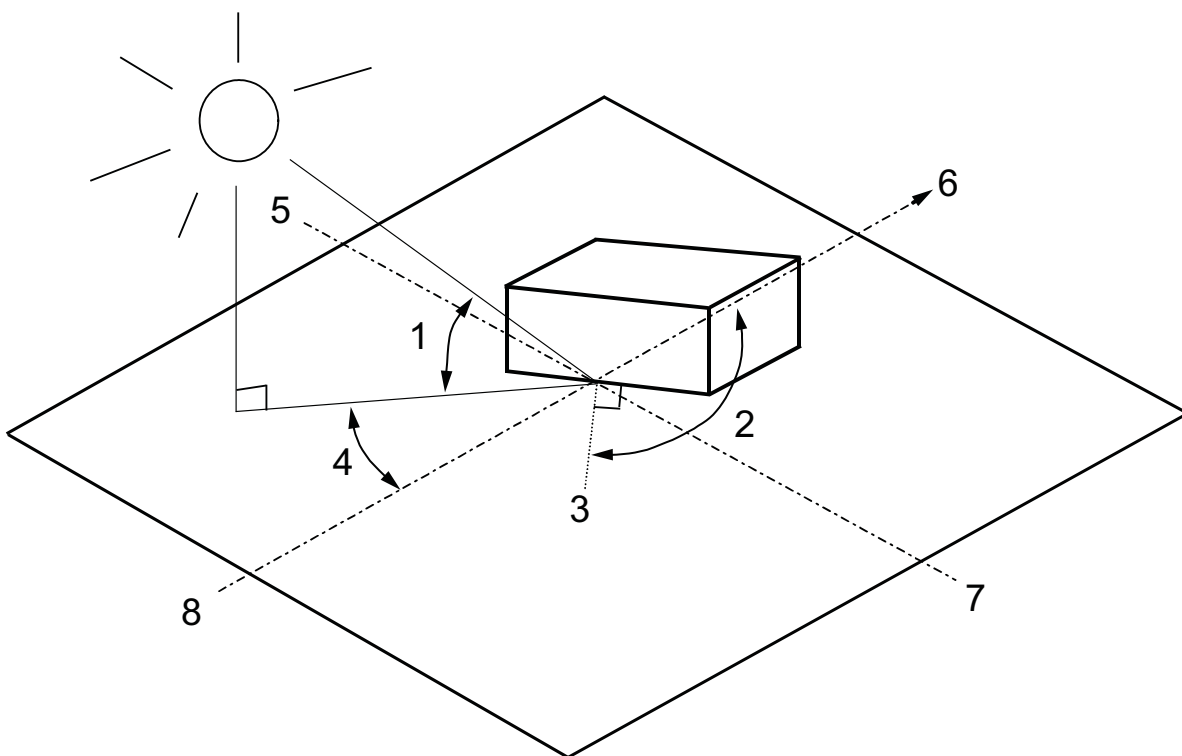

**Key**

- |                                |         |
|--------------------------------|---------|
| 1 solar altitude angle $\beta$ | 5 west  |
| 2 wall azimuth angle $\omega$  | 6 north |
| 3 normal to vertical surface   | 7 east  |
| 4 solar azimuth angle $\gamma$ | 8 south |

**Figure C.1 — Solar azimuth angle  $\gamma$  and solar altitude  $\beta$**



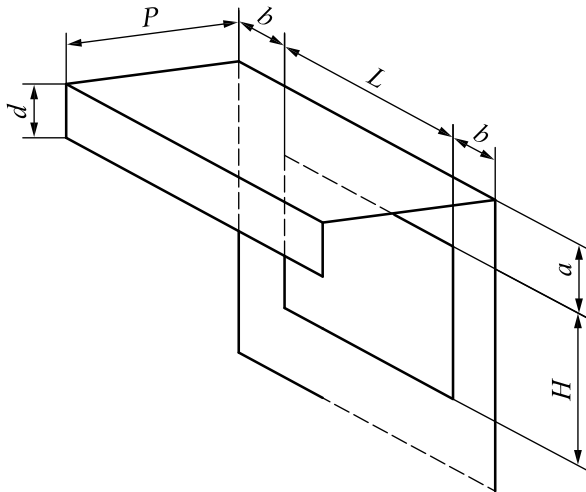

Figure C.2 — Overhang, main dimensions

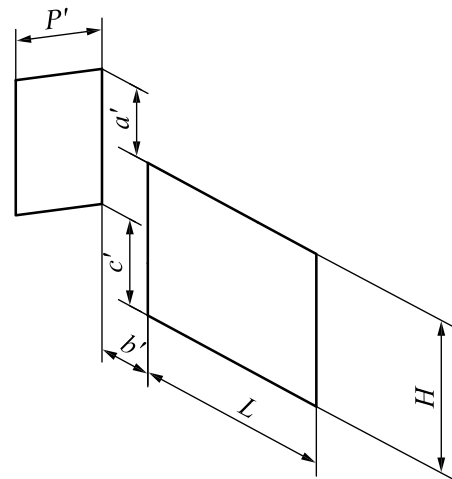

Figure C.3 — Side fin, main dimensions

In this annex the following calculations are introduced:

- a) calculation path for overhang;
- b) calculation path for vertical projection and the end of the overhang;
- c) calculation path for side fin;
- d) calculation path for sunlit area due to short side fin.

## C.2 Calculation path for overhang

The width of the overhang is assumed to be equal to or greater than that of the window. The overhang can be located at the head of the window, or at distance  $a$  above the head of the window. Figure C.4 shows a typical shadow cast by an overhang. Aside from the fixed physical dimensions of the window arrangement  $L$ ,  $H$ ,  $a$  and  $b$ , all equations are expressed in terms of the shadow depth  $T$  and the shadow offset  $M$  cast by overhang, where, in Equation (C.1):

$$\begin{aligned} T &= P \frac{\tan \beta}{\cos \gamma} \\ M &= P \tan \gamma \end{aligned} \tag{C.1}$$

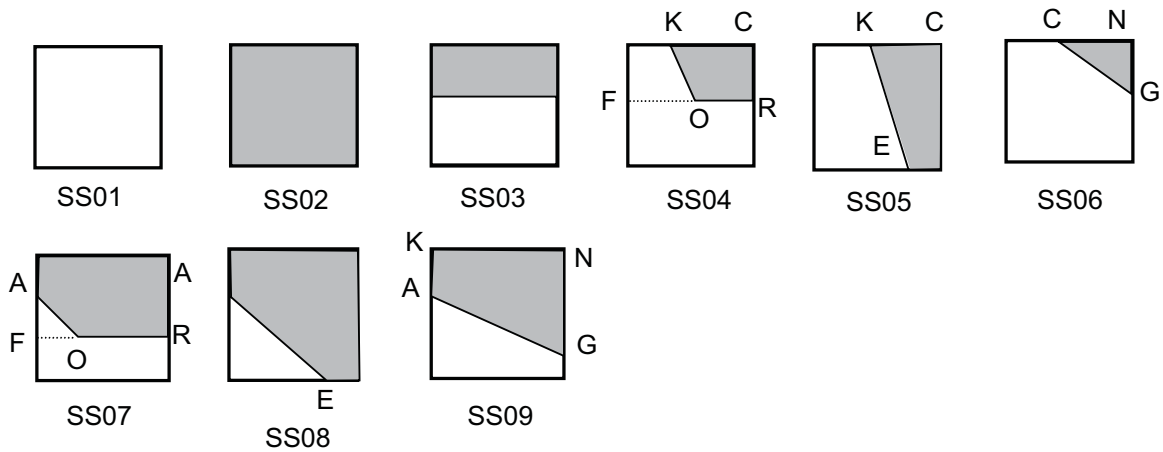

Figure C.4 — Shadow shapes of overhangs

The areas of the shadow shapes cast by an overhang, reported in Figure C.4 from SS01 to SS09, are in Equation (C.2) as follows:

$$A_{01} = 0$$

$$A_{02} = H L$$

$$A_{03} = L (T - a)$$

$$A_{04} = (T - a) \left[ L + b - \frac{M \left( 1 + \frac{a}{T} \right)}{2} \right]$$

$$A_{05} = H \left\{ L - \left[ \left( a + \frac{H}{2} \right) \frac{M}{T} \right] + b \right\}$$

$$A_{06} = \left\{ \left[ \left( L + b \right) \frac{T}{M} \right] - a \right\}^2 \left( \frac{M}{2 T} \right)$$

(C.2)

$$A_{07} = \left[ (T - a) L \right] - \left[ (M - b)^2 \frac{T}{2 M} \right]$$

$$A_{08} = H L - \left\{ \left[ \left( H + a \right) \frac{M}{T} \right] - b \right\}^2 \frac{T}{2 M}$$

$$A_{09} = L \left[ \left( b + \frac{L}{2} \right) \frac{T}{M} - a \right]$$

### C.3 Calculation path for vertical projection at the end of the overhang

The width of the vertical projection is assumed to be equal to that of the overhangs. The area equations for the shadow shapes cast by a vertical projection at the end of an overhang, shown in Figure C.5 from SSV1 to SSV9, are in Equation (C.3) as follows:

$$\begin{aligned}
 A_{v1} &= 0 \\
 A_{v2} &= H L \\
 A_{v3} &= L (T + d - a) \\
 A_{v4} &= H (L + b - M) \\
 A_{v5} &= (T + d - a)(L + b - M) \\
 A_{v6} &= L d \\
 A_{v7} &= L (H + a - T) \\
 A_{v8} &= (L + b - M) d \\
 A_{v9} &= (L + b - M) (H + a - T)
 \end{aligned}
 \tag{C.3}$$

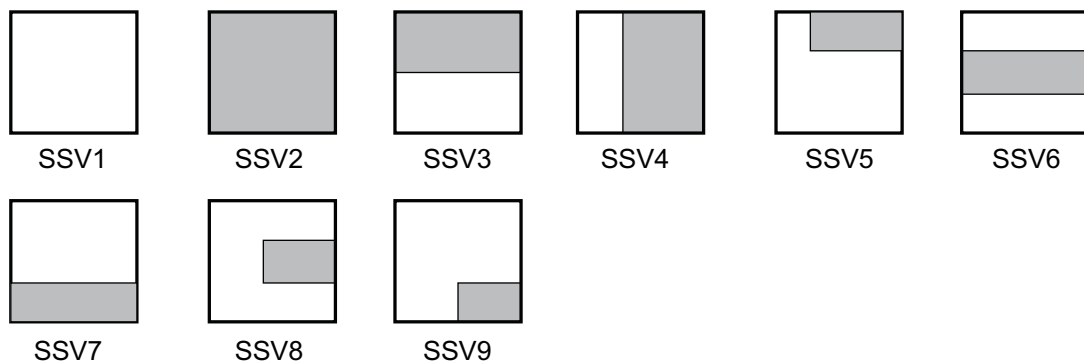

Figure C.5 — Shadow shapes of vertical projections at the end of overhangs

#### C.4 Calculation path for side fin

In order to include shadows cast by a sun hood (external shading device consisting of an overhang and side fins covering only the upper part of the window) or by the side of a balcony, fins are assumed to have any length greater than, less than or equal to the height of a window. They can be located at the window jamb, or a distance  $b'$  away from window jamb (Figure C.3). Dimension  $a'$  is considered positive when the fin extends above the window and negative when it stops below the head of the window. Dimension  $c'$  is considered to be zero in this part of calculation. Any sunlit area, resulting from a short fin that stops above the window sill level, will be deducted in the fourth part of the calculation. The calculation path for the side fin is very similar to that of the overhang. The area equations for the shadow shapes cast by the side fins, shown in Figure C.6 from SSF1 to SSF9, are as in Equation (C.4):

$$A_{F1} = 0$$

$$A_{F2} = H L$$

$$A_{F3} = H (M' - b')$$

$$A_{F4} = (M' - b') \left\{ (H + a') - \left[ \frac{T' \left( 1 + \frac{b'}{M'} \right)}{2} \right] \right\}$$

$$A_{F5} = L \left\{ H - \left[ \left( b' + \frac{L}{2} \right) \frac{M'}{T'} \right] + a' \right\}$$

$$A_{F6} = \left\{ \left[ \left( H + a' \right) \frac{M'}{T'} \right] - b' \right\}^2 \left( \frac{T'}{2M'} \right)$$

$$A_{F7} = \left[ (M' - b') H \right] - \left[ (T' - a')^2 \frac{M'}{2T'} \right]$$

$$A_{F8} = H L - \left\{ \left[ \left( L + b' \right) \frac{T'}{M'} \right] - a' \right\}^2 \frac{M'}{2T'}$$

$$A_{F9} = H \left[ \left( a' + \frac{H}{2} \right) \frac{M'}{T'} - b' \right]$$

(C.4)

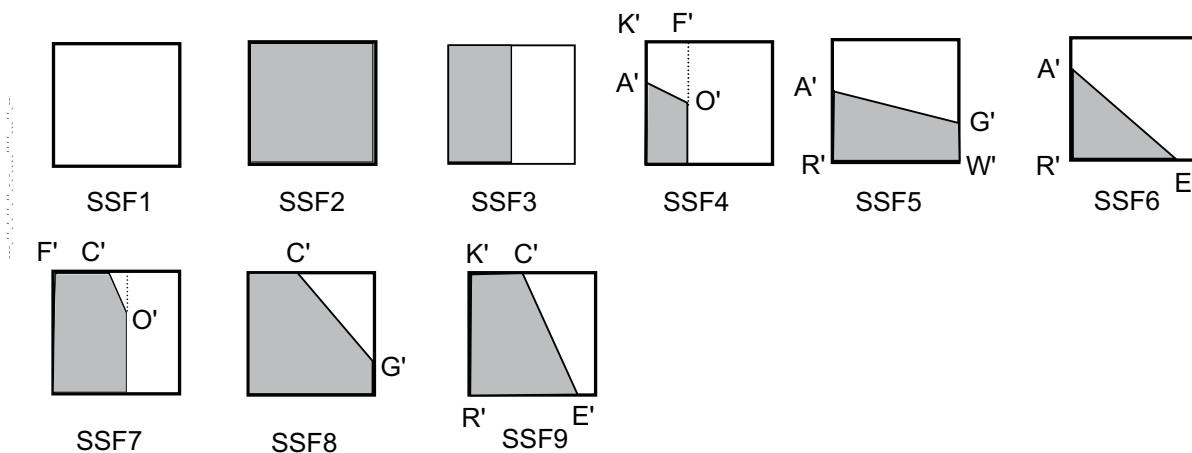

Figure C.6 — Shadow shapes of side fins

It should be noted that these equations have the same form as the equations for the overhang with variables  $T$ ,  $M$ ,  $H$ ,  $L$ ,  $a$  and  $b$  replaced by  $T'$ ,  $M'$ ,  $L$ ,  $H$ ,  $a'$  and  $b'$  respectively.

### C.5 Calculation of the sunlit area due to short side fin

The shadow area equations for the various situations shown in Figure C.7 from SF1 to SF4 are as in Equation (C.5):

$$\begin{aligned}
 A_{SF1} &= 0 \\
 A_{SF2} &= -(M' - b') \left\{ c' - \left[ T' \frac{(1 + b' M')}{2} \right] \right\} \\
 A_{SF3} &= -L \left\{ c' - \left[ \left( b' + \frac{L}{2} \right) \frac{T'}{M'} \right] \right\} \\
 A_{SF4} &= - \left[ c' - \left( b' \frac{T'}{M'} \right) \right]^2 \frac{M'}{2 T'}
 \end{aligned}
 \tag{C.5}$$

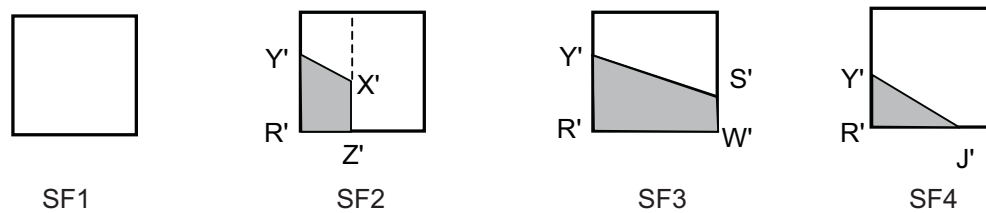

Figure C.7 — Shapes of sunlit area due to short side fins

The minus signs indicate that these areas, if they occur, should be deducted from the previously accumulated shadow areas. The accumulation process is now necessary when different solutions are present. The algorithm, guided by a series of control statements, enters the shadow evaluation process and follows a single path through the flow chart. Along each of the path segments, the algorithm calculates and accumulates a particular set of shadow areas cast by overhang, vertical projection and side fin  $T'$  and shadow for use in the solar contribution for calculation. The shading devices considered in this algorithm are those of the most commonly used shapes. Other shapes can be introduced by expanding the algorithm.

## C.6 External obstruction

When external obstructions are present, the following procedure can be used to determine the shaded area. This procedure is approximate and it is applicable when the wall or window is relatively small in comparison to the shading object. The wall or window is considered either completely shaded or completely in the sun. A partially shaded wall or window can be considered as either completely shaded or completely in the sun depending on the location of the wall reference point. Figure C.8 shows a typical wall-shading object relationship. It should be noted that the reference point may be located at any point on the wall or window. Locating the reference point at the top of the wall or window, as shown in the elevation in Figure C.8, is slightly conservative as compared to the reference point located at the centre of the wall or window. For the application of the procedure the following data are required:

- azimuth shaded angles,  $\alpha_1$ ;  $\alpha_2$  (right +, left -);
- altitude shadow limit angles,  $\delta_1$ ;  $\delta_2$ ;
- wall azimuth angle,  $\omega$ ;
- solar azimuth angle,  $\gamma$ ;
- solar altitude angle,  $\beta$ ;
- limiting points of obstruction, M, N.

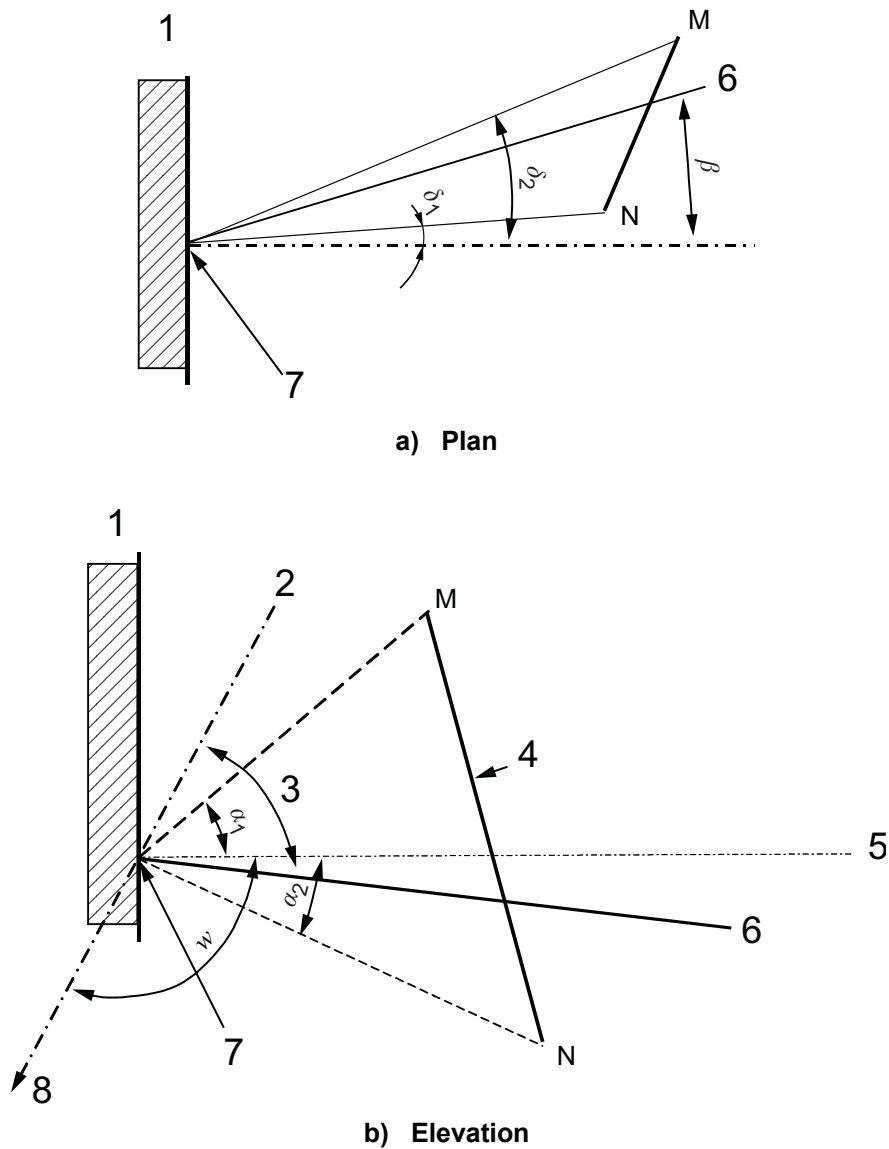

**Key**

1 wall	5 normal to the wall
2 south	6 sun ray
3 solar azimuth angle $\gamma$	7 reference point
4 shading object	8 north

**Figure C.8 — Reference points and angles**

This procedure determines whether the wall is sunlit or shaded.

For the given position of the sun:

- a) determine the wall-solar azimuth angle  $\chi = \gamma - \omega$ ;
- b) if  $\chi < \alpha_1$  or  $\chi > \alpha_2$  the window is in the sun;
- c)  $\alpha_2 > \chi > \alpha_1$   $A = \chi - \alpha_1$ ;  $B = \delta_1 + A(\delta_2 - \delta_1)$ ;
- d) if  $\beta > B$  the wall is in the sun; otherwise it is in the shade.

## C.7 Sunlit factor

The area equations in C.2 to C.6 determine the amount of the shaded area  $A_{sh}$  of the component.

The sunlit area is given by Equation (C.6):

$$A_s = A - A_{sh} \quad (C.6)$$

The sunlit factor  $f_s$  is determined as Equation (C.7):

$$f_s = 1 - A_{sh}/A \quad (C.7)$$

where

$A_s$  is the shaded area;

$A$  is the total area.

## Annex D (informative)

### Design climatic data in the warm season

Design warm weather conditions (cloudless sky) occur on relatively few days in summer. If solar radiation produces a large proportion of heat flow, it is essential to calculate the internal temperature for several months separately. As a consequence, design climatic data should be generally defined for all months. The following characteristics of the design climatic data for design temperature calculations can be used.

- 1) From a long-term data set, identify for each month and for each year the hottest four-day spell. This is defined as a non-overlapping period of four days with the highest average of daily mean temperature.
- 2) For the chosen month identify discrete four-day spells with an average period of one per year. This would mean looking at daily temperature data for each day of the chosen month and selecting, for example, the hottest 20 spells from a 20-year data set.
- 3) Exclude 50 % of these spells on the basis of low average temperature (those four-day averages of daily mean temperatures which lie below the median, where the four-day averages are rounded to the nearest 0,5 °C).
- 4) Exclude 50 % of remaining spells on the basis of high diurnal range (those four-day averages of daily temperature range which lie above the median, where the four-day averages are rounded to the nearest 0,5 °C).

This will produce a final selection of four-day spells of critical conditions with a return period of four years.

- 5) Calculate the hourly averages of temperature and radiation for each hour in each day in the selected spells and take these as design values.
- 6) Calculate the averages of daily mean wind speed for each day in the selected spells and take these as design values for the corresponding day in the four-day sequence.

NOTE Methods of calculation and presentation of climatic data are given in ISO 15927-2.



## Annex E (informative)

### Calculation of the internal long-wave radiation exchanges in buildings

#### E.1 Introduction

This annex gives a simplified procedure for evaluating the internal long-wave radiation exchanges in buildings.

#### E.2 Limits of application

The procedure can be applied for situations where

- the emissivities of the various surfaces are similar;
- the geometry of the room is simple (rectangular).

For special situations the solution techniques reported in scientific literature should be referred to (see Bibliography).

#### E.3 Calculation procedure

The total net long-wave radiation at the  $n^{\text{th}}$  internal surface is calculated by assuming that each surface  $n$  radiates to a fictitious surface (f), which has the following characteristics:

— area  $A = \sum_{n=1}^N (A)_n$  ( $N = \text{number of the internal surfaces}$ ) (E.1)

— emissivity  $\varepsilon_f = \sum_{n=1}^N (\varepsilon_n A_n) / A_f$  (E.2)

— temperature  $T_f = \sum_{n=1}^N (A_n \varepsilon_n T_n) / (\varepsilon_f A_f)$  (E.3)

The density of radiant heat flow rate  $q_{\text{Iri},k}$  from a surface  $k$  to the others is:

$$q_{\text{Iri},k} = (q'_{\text{Iri},k} - q_{\text{bal}}) \quad \text{(E.4)}$$

where

$$q'_{\text{fri},k} = \sigma F_{\text{if}} (T_{\text{f}}^4 - T_k^4) \quad (\text{E.5})$$

$$F_{k,\text{f}} = 1 + \frac{1 - \varepsilon_k}{\varepsilon_k} + \frac{A_k (1 - \varepsilon_k)}{A_{\text{f}} \varepsilon_{\text{f}}} \quad (\text{E.6})$$

$$q_{\text{bal}} = \sum_{k=1}^N (q'_{\text{fri},k} A_k) / A_{\text{f}} \quad (\text{E.7})$$

© ISO 2012 – All rights reserved

## Annex F (informative)

### External radiative long-wave heat transfer coefficients

#### F.1 Introduction

This annex gives the terms influencing the long-wave radiation exchanges at the external surfaces and provides a procedure for the evaluation of the external long-wave heat transfer coefficient.

#### F.2 Terms and calculation procedure

Long-wave radiation is emitted by all solids, fluids and most gaseous molecules. External building elements exchange radiation with the sky, the ground, surrounding buildings and plants. For the long-wave radiation balance the view factor  $F$  between each environmental radiator and the surface is very important. Assuming that all surrounding radiators are black bodies and the surface considered has an emissivity  $\varepsilon$ , the net long-wave radiant flux density  $q_{lr,e}$  for an external surface is calculated in Equation (F.1) as:

$$q_{lr,e} = \varepsilon \sigma (F_{sk} T_{sk}^4 + F_b T_b^4 + F_g T_g^4 - T_{es}^4) \quad (F.1)$$

where

$F_{sk}$  is the view factor with the sky;

$F_b$  is the view factor with other buildings;

$F_g$  is the view factor with the ground;

$T_{sk}$  is the absolute temperature of the sky;

$T_b$  is the absolute temperature of other buildings;

$T_g$  is the absolute temperature of the ground;

$T_{es}$  is the external surface temperature of the wall;

$\varepsilon$  is the emissivity of the surface;

$\sigma$  is the Stefan-Boltzmann constant.

View factors depend on the orientation of the surface and on the type of the environments. Table F.1 gives typical view factors for different situations.

Table F.1 — View factors for external environments

Type of “environment”	Vertical surface		
	$F_{sk}$	$F_b$	$F_g$
City centre	0,33	0,34	0,33
Suburban area	0,41	0,18	0,41
Rural area	0,45	0,10	0,45
	Horizontal surface (roof)		
	$F_{sk}$	$F_b$	$F_g$
All environments	1,00	0,00	0,00

The temperatures included in Equation (F.1) are approximated as follows:

$$T_{sk} = \left[ 9,36 \times 10^{-6} \times (T_{a,e})^6 \right]^{0,25} \quad (F.2)$$

$$T_b = T_{a,e}$$

$$T_g = T_{a,e}$$

where  $T_{a,e}$  is the external air temperature, in kelvins.

Equation (F.1) can be written as:

$$q_{l,r,e} = h_{lr} (T_{a,e} - T_{es}) + q_{e,r} \quad (F.3)$$

with

$$h_{lr} = 4 \varepsilon \sigma T_m^3 \quad (F.4)$$

$$q_{e,r} = F_{sk} \varepsilon \sigma (T_{sk}^4 - T_{a,e}^4) \quad (F.5)$$

$$T_m = \frac{T_{a,e} + T_{s,e}}{2} \quad (F.6)$$

## Annex G (informative)

### Solar factors

#### G.1 Introduction

This annex gives the procedures for determining the solar factors introduced in 4.5.3.2 of this International Standard.

#### G.2 Solar to air factor

The solar to air factor,  $f_{sa}$ , is the fraction of the solar heat entering through the glazing and immediately transferred to the internal air. This fraction depends on the quantity of internal items with very low thermal capacity, such as carpets and furniture. Typical values of the solar to air factor are given in Table G.1 according to the amount of furniture.

**Table G.1 — Solar to air factor  $f_{sa}$**

Amount of furniture	Solar to air factor, $f_{sa}$
No furniture	0
Small amount of furniture	0,10
Large amount of furniture	0,20

#### G.3 Distribution factors

The distribution factors,  $f_{df}$ , are the fraction of the direct solar radiation absorbed per area of the different internal surfaces of the walls, ceiling, floor, etc. They depend on the solar angles, the geometrical dimensions of glazing and the room, the short-wave reflectance of components, and the furniture and furnishings. It is assumed to be time-independent. Typical values of the distribution factors are given in Table G.2 as a function of the area-weighted average reflectance,  $\rho_m$ , and the area of the envelope elements.

**Table G.2 — Distribution factors**

Room reflectance	Floor	Vertical walls	Ceiling	Glazing
$\rho \geq 0,7$	$1/A_T$	$1/A_T$	$1/A_T$	$1/A_T$
$0,3 \leq \rho < 0,7$	$0,5/A_f$	$0,4/A_{wa}$	$0,1/A_c$	0,0
$\rho < 0,3$	$0,6/A_f$	$0,35/A_{wa}$	$0,05/A_c$	0,0

where

$A_f$  is the floor area, in m<sup>2</sup>;

$A_{wa}$  is the area of all (external and internal) vertical opaque walls, in m<sup>2</sup>;

$A_c$  is the ceiling/roof area, in m<sup>2</sup>;

$A_T$  is the total envelope area excluding glazing, in m<sup>2</sup>.

The area weighted average reflectance is given by Equation (G.1):

$$\rho_m = \frac{\sum_{j=1}^N A_j \rho_j}{\sum_{j=1}^N A_j} \tag{G.1}$$

### G.4 Solar loss factor

The solar loss factor,  $f_{lf}$ , is the fraction of the solar radiation entering through the glazing and reflected back to the external environment. It depends on the geometrical characteristics and solar properties of the glazing system, the exposure of the window, the solar angles and the room colour and geometry. It is assumed to be time-independent. A detailed and exact calculation method of the short-wave radiation back to the window is much too complicated for the purposes of this International Standard. It is nevertheless possible to apply here a simplified approach considering the following assumptions:

- the view factors for the various internal surfaces are not considered;
- the solar reflection factor for all surfaces is the same;
- the solar transmittance of the glazing system refers to the direct solar radiation component.

The solar loss factor is given by Equation (G.2):

$$f_{lf} = \frac{\tau A_w}{A_t(1 - \rho_m)} \tag{G.2}$$

where

$\tau$  is the solar transmittance of the glazing system;

$A_w$  is the window area;

$A_t$  is the room overall surface area;

$\rho_m$  is the average solar reflection coefficient of room surfaces [defined in Equation (G.1)].

Examples of solar loss factors for different room geometries and solar transmittance of glazing components are given in Table G.3 for a room having an average solar reflection of 0,5 and height 2,7 m.

**Table G.3 — Examples of solar loss factors**

$\tau$	Glazing system	Window area/Floor area		
		large > 0,375	medium 0,25	small < 0,125
0,8	Clear glazing	0,12	0,08	0,04
0,5	Clear glazing with external shade	0,07	0,05	0,02

## Annex H (informative)

### Internal gains

#### H.1 Introduction

This annex gives typical values of heat flow due to internal energy sources for residential and non-residential buildings.

#### H.2 Residential building

Table H.1 gives the values of the total heat flow rate due to internal sources for different residential rooms.

**Table H.1 — Heat flow rate per floor area**

Hour	Kitchen W/m <sup>2</sup>	Dining room W/m <sup>2</sup>	Bedroom W/m <sup>2</sup>	Bathroom W/m <sup>2</sup>
1	5	0	5	0
2	5	0	5	0
3	5	0	5	0
4	5	0	5	0
5	5	0	5	0
6	5	0	5	0
7	10	1	2	3
8	10	1	2	3
9	7	1	2	3
10	7	1	0	1
11	7	10	0	1
12	10	10	0	1
13	15	10	0	1
14	15	10	0	1
15	10	1	0	1
16	5	1	0	1
17	5	1	0	1
18	15	15	0	1
19	15	15	0	3
20	15	15	0	3
21	10	15	0	3
22	5	10	2	3
23	5	0	5	0
24	5	0	5	0

### H.3 Non-residential building

For a non-residential building the effect of the internal sources can be very important. In the following tables suggested values of the heat gain attributable to people, lighting and office equipment are given.

**Table H.2 — Sensible metabolic heat gains of people in offices**

Description	Total heat gain W per person	Radiant heat gain W per person
Drawing office	100	55
High technology office	80	50
Executives office	80	50
Computer suite	80	50
Conference room	80	50
Circulation area	93	37
Toilet	93	37
Restaurant	107	43

**Table H.3 — Heat gains from office lighting system**

System	Heat gain for floor area W per m <sup>2</sup> floor area	Radiant fraction of the total heat gain W per m <sup>2</sup> floor area
General office	15	6,8
Drawing office	22	9,9
High technology office	9	4,0
Executives office	12	5,4
Computer suite	9	4,0
Conference room	9	4,0
Circulation area	5	2,3
Toilet	7	3,2

**Table H.4 — Heat released from office equipment**

Description	m <sup>2</sup> per person	Total heat gain W/m <sup>2</sup>	Radiant fraction of the total heat gain W/m <sup>2</sup>
General office	6	16	4,9
Drawing office	6	7	2,1
High technology office	6	35	8,4
Executives office	33	7	1,9
Computer suite	20	350	77,0
Conference room	2	5	0,0
Circulation area	2	5	0,0



## Annex I (informative)

### Air ventilation

#### I.1 Introduction

This annex gives a procedure for the evaluation of the air flow rate due to natural ventilation through the openings in building. In the absence of a standard giving a detailed model based on the air mass balance, this annex can be used.

#### I.2 Calculation procedure

##### I.2.1 General

The amount of air flowing into the building depends upon the pressure difference between the internal and the external environments and also on the resistance that any openings give to the flow of air. The pressure difference is produced by the action of the wind flow around the building and by the difference in the density of the internal and external air. The aerodynamics of the air flowing are complex but, by deeming openings to be classifiable within two general types, it is possible to specify simple formulae to relate the flow rate to the pressure difference. These categories are:

- a) cracks, or small openings with a typical dimension less than approximately 10 mm;
- b) openings with a typical dimension larger than approximately 10 mm.

##### I.2.2 Cracks and small openings

For cracks the ventilation rate is given in Equation (I.1) as:

$$m_a = l \rho k \left( \frac{\Delta p}{\Delta p_0} \right)^n \quad (\text{I.1})$$

where

$\rho$  is the density of the air;

$k$  is the crack coefficient;

$l$  is the length of the crack, in metres;

$\Delta p$  is the applied pressure difference, in Pa;

$\Delta p_0$  is the pressure difference for which  $k$  is determined, in Pa;

$n$  is the flow exponent.

Table I.1 gives a range of values of  $k$  for the cracks formed around the opening lights of closed windows, which can be used when national values are not available. A suitable value for  $n$  is 0,67. The pressure difference between internal and external environments is obtained by adding the thermal buoyancy  $\Delta p_T$  and the wind contribution  $\Delta p_W$ .

$$\Delta p = \Delta p_T + \Delta p_w \tag{1.2}$$

The thermal buoyancy  $\Delta p_T$  contribution is given by Equation (1.3):

$$\Delta p_T = \left( \frac{\Delta T \rho g H_1}{T_m} \right)^{0,5} \tag{1.3}$$

where

$\Delta T$  is the temperature difference between internal and external environments;

$T_m$  is the reference temperature (300 K);

$g$  is the acceleration due to gravity (= 9,81 m/s<sup>2</sup>);

$\rho$  is the air density;

$H_1$  is the height between high and low level.

The wind contribution  $\Delta p_w$  is given by Equation (1.4):

$$\Delta p_w = \Delta C_w \frac{\rho v_r^2}{2} \tag{1.4}$$

where

$\rho$  is the air density;

$v_r$  is the wind reference velocity;

$\Delta C_w$  is the applied differential mean pressure coefficient calculated as difference between the mean surface pressure coefficients, derived from Table I.2 for the opposite walls perpendicular to the wind direction.

**Table I.1 — Values of  $k$  for windows (in litres cubic metres per second and per metre of crack length for an applied pressure difference of 1 Pa)**

Window type	Value of $k$ ( $\times 10^{-3}$ )	
	average	range
Sliding	0,08	0,02 to 0,30
Pivoted	0,21	0,06 to 0,80
Pivoted (weather stripped)	0,08	0,005 to 0,20

### I.2.3 Large openings

#### I.2.3.1 General

The air flow rate can be evaluated by the approximate formula shown in Equation (1.5):

$$m_a = \rho c_d A \left( \frac{2 \Delta p}{\rho} \right)^{0,5} \tag{1.5}$$

where

$c_d$  is the coefficient of discharge;

$A$  is the area of opening;

$\Delta p$  is the pressure difference;

$\rho$  is the air density.

Values of the coefficient  $c_d$  and area  $A$  depend on the position and flow characteristics of all openings. It is usual to assign a value to the discharge coefficient corresponding to that for a sharp-edged orifice, taken here as 0,61. The value of  $A$  for other types of opening then becomes the equivalent area associated with that particular opening. Pressure generated by forces of wind and temperature difference produces a movement of air through these openings governed by the fact that the total flow of air into the circulation space equals the outgoing flow rate. Because of the impossibility to obtain a detailed solution for existing buildings, the solution is given for simple cases.

Figure I.2 shows a simple two dimensional representation of a building with no internal divisions and therefore consisting of a single cell with openings as shown, i.e. two ( $A_1$  and  $A_3$ ) at high level, and two ( $A_2$  and  $A_4$ ) at low level. According to the wind and temperature situation the air flow by natural ventilation is determined as follows. Figure I.3 shows a similar representation for a building without any internal partition and with openings on one side and one level only.

### I.2.3.2 Simple buildings: openings on two facades

#### I.2.3.2.1 Wind only

$$m_{a,w} = \rho c_d A_w v_r (\Delta C_w)^{0,5} \quad (I.6)$$

and

$$v_r = K z^a v_f \quad (I.7)$$

where

$K$  is a coefficient as given in Table I.3;

$a$  is an exponent as given in Table I.3;

$z$  is the height of the building, in metres;

$v_f$  is the free wind velocity, in m/s.

$$\frac{1}{A_w^2} = \frac{1}{(A_1 + A_2)^2} + \frac{1}{(A_3 + A_4)^2} \quad (I.8)$$

Equation (I.8) is only applicable when all openings have the same  $c_d$  values.

where  $\Delta C_w$  is the applied differential mean pressure coefficient calculated as difference between the mean surface pressure coefficients, derived from Table I.2 for the opposite walls perpendicular to the wind direction.

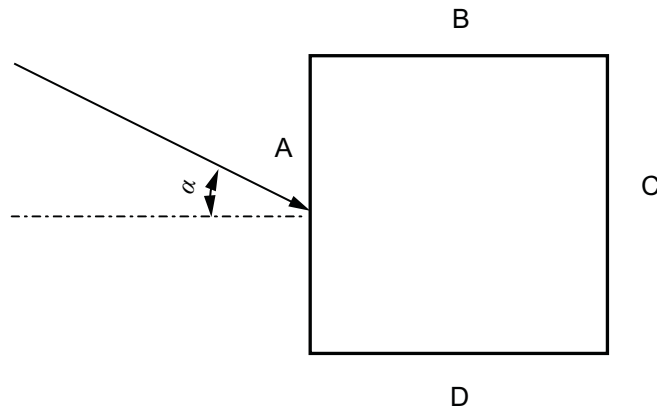

**Key**  
 $\alpha$  wind angle  
 A, B, C, D positions of the external surfaces of a room in plan view

**Figure I.1 — Number of surfaces with respect to the wind direction**

**Table I.2 — Coefficient  $C_w$  as a function of the wind angle and building proportions**

Building height ratio $h/w$	Building plan ratio $l/w$	Wind angle $\alpha$	$C_w$ surfaces			
			A	B	C	D
$(h/w) < 1/2$	$1 < (l/w) \leq 3/2$	0	0,7	-0,2	-0,5	-0,5
		90	-0,5	-0,5	0,7	-0,2
	$3/2 < (l/w) < 4$	0	0,7	-0,2	-0,6	-0,6
		90	-0,5	-0,5	0,7	-0,1
$1/2 \leq (h/w) < 3/2$	$1 < (l/w) \leq 3/2$	0	0,7	-0,2	-0,6	-0,6
		90	-0,6	-0,6	0,7	-0,2
	$3/2 < (l/w) < 4$	0	0,7	-0,3	-0,7	-0,7
		90	-0,5	-0,5	0,7	0,1
$3/2 \leq (h/w) < 6$	$1 < (l/w) \leq 3/2$	0	0,8	-0,2	-0,8	-0,8
		90	-0,8	-0,8	0,8	-0,2
	$3/2 < (l/w) < 4$	0	0,7	-0,4	-0,7	-0,7
		90	-0,5	-0,5	0,8	-0,1

where  
 $h$  height of the building;  
 $l$  length of the building;  
 $w$  depth of the building.

Table I.3 — Coefficient  $K$  and exponent  $a$ 

Terrain	$K$	$a$
Open flat country	0,68	0,17
Country with scattered wind breaks	0,52	0,20
Sub-urban	0,35	0,25
City centre	0,21	0,33

### I.2.3.2.2 Temperature difference only

$$m_{a,T} = c_d \rho A_T \left( \frac{2 \Delta \theta g H_1}{T_m} \right)^{0,5} \quad (I.9)$$

$$\frac{1}{A_T^2} = \frac{1}{(A_1 + A_3)^2} + \frac{1}{(A_2 + A_4)^2} \quad (I.10)$$

where

$c_d$  is the coefficient of discharge;

$m_{a,T}$  is the mass flow rate due to temperature difference;

$\Delta \theta$  is the temperature difference between internal and external environments;

$T_m$  is the reference temperature (300 K);

$g$  is the acceleration due to gravity (= 9,81 m/s<sup>2</sup>);

$H_1$  is the height between high and low level.

Equation (I.10) is only applicable when all openings have the same  $C_d$  values.

### I.2.3.2.3 Wind and temperature difference together

$$m_a = m_{a,T} \quad \text{for} \quad \frac{v_f}{(\Delta T)^{0,5}} < \left[ 0,26 \times \left( \frac{A_T}{A_w} \right)^{0,5} \left( \frac{H_1}{\Delta c_p} \right)^{0,5} \right]$$

$$m_a = m_{a,w} \quad \text{for} \quad \frac{v_f}{(\Delta T)^{0,5}} > \left[ 0,26 \times \left( \frac{A_T}{A_w} \right)^{0,5} \left( \frac{H_1}{\Delta c_p} \right)^{0,5} \right] \quad (I.11)$$

### I.2.3.3 Openings in one wall only

#### I.2.3.3.1 Wind

$$m_{a,w} = 0,025 \times A_w v_r \quad (I.12)$$

where  $v_r$  is defined by Equation (I.7).

**I.2.3.3.2 Temperature differences with openings at two levels**

$$m_{a,T} = c_d \rho A_T \left( \frac{2\Delta\theta g H_1}{T_m} \right)^{0,5} \tag{I.13}$$

where

$A_T$  is determined from Equation (I.10);

$c_d$  is the coefficient of discharge.

**I.2.3.3.3 Temperature difference with an opening at one level only**

$$m_{a,T} = c_d \rho \frac{A_T}{3} \left( \frac{\Delta\theta g H}{T_m} \right)^{0,5} \tag{I.14}$$

where  $H$  is the opening height.

**I.3 Example of calculation of natural ventilation rates for simple building**

**I.3.1 General**

Consider a building consisting of a single undivided space 25 m long, 10 m wide and 8 m high. Given that the building is situated in an open suburban area, calculate:

- a) the natural ventilation rate due to wind;
- b) the ventilation rate due to the effect of a temperature difference of 6 K in the absence of the wind.

There are no ventilation openings on the shorter walls. On each of the longer walls there are openings of 2,5 m<sup>2</sup> at low level, and 5,0 m<sup>2</sup> at high level, separated by a vertical distance of 6,0 m, and evenly distributed along the length of the wall.

**I.3.2 Wind**

**Determination of the pressure coefficient difference**

Building height ratio = 0,8

Building plan ratio = 2,5

Thus, from Table I.2, the difference in mean surface pressure coefficients at the two long sides A and C of the building for a perpendicular wind is:

$$\Delta C_w = 0,7 - (-0,3) = 1,0$$

**Determination of  $v_f$**

From climatic data table,  $v_f = 3,75$  m/s

**Terrain:** country with scattered wind breaks:

From Table I.3:

$$K = 0,52;$$

$$a = 0,20.$$

Thus, from Equation (I.7), using the building height of 8 m:

$$v_r = 3,75 \times 0,52 \times (8)^{0,2} = 2,96 \text{ m/s}$$

#### Determination of $A_w$

From Equation (I.8):

$$1/(A_w)^2 = 1/(5,0 + 2,5)^2 + 1/(5,0 + 2,5)^2$$

$$A_w = 5,3 \text{ m}^2$$

#### Determination of ventilation rate

Using Equation (I.6):

$$m_{a,w} = (0,61 \times 5,3 \times 2,96 \times 1)^{0,5} = 3,09 \text{ m}^3/\text{s}$$

The volume of the building is  $V = 25 \times 10 \times 8 = 2\,000 \text{ m}^3$

The air change rate is  $3\,600 \times 3,09 / 2\,000 = 5,57$  air changes/hour

### I.3.3 Temperature difference

From the information given:

Temperature difference  $\Delta\theta = 6 \text{ K}$

Height between openings  $H_1 = 6,0 \text{ m}$

Thus from Equation (I.10):

$$1/(A_T)^2 = [1/(2,5 + 2,5)^2] + [1/(5,0 + 5,0)^2]$$

$$A_T = 4,47 \text{ m}^2$$

Taking  $T_m = 300 \text{ K}$  and  $\rho = 1,2 \text{ kg/m}^3$

$$m_{a,T} = 0,61 \times 1,2 \times \frac{4,47}{3} \times \left( \frac{6 \times 9,8 \times 6}{300} \right)^{0,5} = 1,183 \text{ m}^3/\text{s}$$

The air change rate is:

$$3\,600 \times 1,183 / 2\,000 = 2,13 \text{ air changes/hour}$$

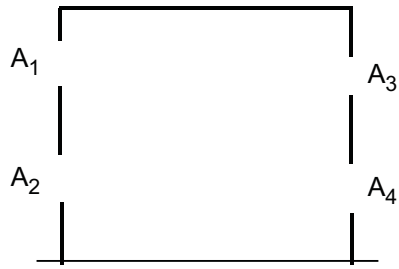

Figure I.2 — Openings on two sides

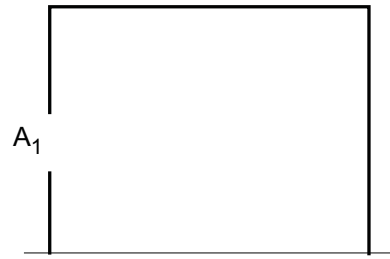

Figure I.3 — Opening on one side



## Annex J (informative)

### Detailed results of the validation tests considered in the “whole validation model” procedure

This annex gives the hourly values of the operative temperature for the various tests considered in the “whole calculation method” included in 8.3.

**Table J.1 — Geometry A: Hourly values of the operative temperature**

Hours	A1a	A1b	A1c	A2a	A2b	A2c	A3a	A3b	A3c
0 to 1	36,8	27,8	27,8	36,7	28,4	28,2	39,2	30,0	29,2
1 to 2	36,3	27,2	27,2	36,4	28,0	27,7	38,9	29,5	28,8
2 to 3	35,9	26,7	26,7	36,2	27,6	27,3	38,6	29,0	28,3
3 to 4	35,5	26,2	26,2	36,0	27,2	27,0	38,4	28,6	28,0
4 to 5	35,1	25,8	25,8	35,8	26,9	26,7	38,1	28,3	27,6
5 to 6	34,9	25,5	25,6	35,6	26,8	26,6	38,0	28,1	27,5
6 to 7	34,8	26,8	25,6	35,6	28,4	26,6	37,9	30,1	27,5
7 to 8	34,8	27,3	25,9	35,7	28,9	26,9	38,0	30,8	27,8
8 to 9	35,0	27,7	26,4	35,8	29,3	27,4	38,1	31,2	28,3
9 to 10	35,2	28,2	27,2	36,0	29,7	28,0	38,3	31,6	28,9
10 to 11	35,4	28,7	28,1	36,2	30,0	28,8	38,5	32,1	29,6
11 to 12	36,3	29,8	29,6	36,9	30,8	29,9	39,2	33,0	30,9
12 to 13	37,1	30,7	30,9	37,5	31,3	30,9	39,8	33,7	31,9
13 to 14	38,2	31,7	32,2	38,1	31,9	31,7	40,5	34,4	32,9
14 to 15	39,2	32,8	33,3	38,6	32,5	32,4	41,2	35,1	33,7
15 to 16	39,5	33,1	33,6	38,7	32,6	32,6	41,4	35,4	33,9
16 to 17	39,9	33,5	33,8	38,8	32,8	32,6	41,6	35,7	34,0
17 to 18	39,8	33,6	33,4	38,7	32,8	32,3	41,5	35,7	33,6
18 to 19	40,0	32,8	32,9	38,8	32,4	32,0	41,7	34,5	33,3
19 to 20	39,4	31,9	32,0	38,5	31,6	31,3	41,2	33,5	32,5
20 to 21	39,0	31,1	31,2	38,3	31,0	30,7	41,0	32,8	31,9
21 to 22	38,7	30,4	30,4	38,1	30,4	30,1	40,7	32,1	31,2
22 to 23	38,2	29,5	29,6	37,7	29,7	29,4	40,3	31,4	30,5
23 to 24	37,3	28,5	28,5	37,0	28,9	28,6	39,6	30,5	29,7
<b>Average</b>	37,2	29,5	29,3	37,2	30,0	29,4	39,7	32,0	30,5

Table J.2 — Geometry B: Hourly values of the operative temperature

Hours	B1a	B1b	B1c	B2a	B2b	B2c	B3a	B3b	B3c
0 to 1	30,3	19,7	19,4	30,1	20,2	20,0	32,1	21,7	21,0
1 to 2	29,6	18,8	18,6	29,7	19,6	19,4	31,7	21,0	20,4
2 to 3	28,9	18,0	17,8	29,4	19,0	18,8	31,3	20,4	19,8
3 to 4	28,3	17,3	17,1	29,0	18,5	18,3	30,9	19,9	19,3
4 to 5	27,8	16,7	16,5	28,8	18,1	17,9	30,6	19,4	18,9
5 to 6	27,4	16,4	16,2	28,6	17,9	17,7	30,4	19,2	18,6
6 to 7	27,2	17,8	16,2	28,5	19,8	17,8	30,3	21,4	18,7
7 to 8	27,1	18,5	16,5	28,6	20,5	18,1	30,3	22,3	19,0
8 to 9	27,2	19,0	17,1	28,7	21,0	18,7	30,4	22,9	19,5
9 to 10	27,4	19,6	18,1	28,9	21,5	19,5	30,6	23,4	20,4
10 to 11	27,7	20,3	19,4	29,2	21,9	20,6	30,9	23,9	21,4
11 to 12	28,6	21,4	21,3	29,9	22,7	22,0	31,6	24,9	23,0
12 to 13	29,6	22,8	23,2	30,7	23,4	23,3	32,4	25,8	24,4
13 to 14	31,2	24,6	25,1	31,7	24,4	24,6	33,6	26,9	25,7
14 to 15	33,0	26,6	26,8	32,6	25,4	25,7	34,6	28,0	26,9
15 to 16	34,2	28,0	27,7	33,2	26,0	26,2	35,2	28,7	27,5
16 to 17	35,2	29,2	28,1	33,6	26,5	26,4	35,7	29,3	27,7
17 to 18	35,6	29,9	27,8	33,7	26,7	26,2	35,9	29,6	27,5
18 to 19	35,8	28,1	27,2	33,7	26,1	25,7	36,0	28,2	27,0
19 to 20	34,9	26,3	25,7	33,1	24,9	24,6	35,4	26,8	25,8
20 to 21	33,8	24,6	24,2	32,4	23,7	23,5	34,6	25,5	24,6
21 to 22	33,0	23,3	23,0	32,0	22,8	22,6	34,1	24,5	23,7
22 to 23	32,2	22,1	21,8	31,5	21,9	21,6	33,5	23,5	22,8
23 to 24	31,2	20,8	20,5	30,7	20,9	20,7	32,7	22,5	21,8
<b>Average</b>	30,5	21,3	21,5	30,8	22,2	21,7	32,7	24,2	22,7

## Annex K (informative)

### Calculation method for internal humidity without moisture absorption into or desorption from walls and other structures

#### K.1 Introduction

This annex gives the calculation method for internal humidity under the condition that walls and other structures do not absorb or desorb moisture. The absorption and desorption by walls and other structures are not always negligible, especially when there is little ventilation. In many cases, however, the calculation that does not consider moisture absorption or desorption overestimates change (amplitude) in humidity. This enables a conservative evaluation of internal humidity.

#### K.2 Assumptions for the calculation method

This annex defines the method for calculating humidity by mass in a single room on the assumptions that:

- condensation and evaporation will not occur on the surfaces of walls and other structures;
- there is no moisture transfer between room air and various surfaces in a room;
- moisture produced in a room is diffused at once and therefore humidity by mass is uniform in the room.

#### K.3 Calculation of internal humidity

Internal humidity at any given time is determined by solving Equation (K.1), which is similar to Equation (1):

$$V \frac{dv_i}{dt} = G_v + G_i \quad (\text{K.1})$$

where

$V$  is the room volume;

$v_i$  is the internal humidity by volume;

$G_v$  is the influx of water vapour into a room by ventilation;

$G_i$  is the moisture production.

#### K.4 Internal moisture production ( $G_i$ )

Moisture in a room is produced by human activities, such as cooking, doing laundry, washing and bathing, and is generated from plants and flowers, etc. Typical examples of moisture production rates are given in Tables K.1 to K.3 below [16].

**Table K.1 — Moisture production rates in residential buildings**

Activity	Rate of production kg/day
Cooking with electrical range	2,0
Cooking with gas range	3,0
Hand washing	0,4
Bath and shower for personal hygiene	0,2
Manual washing of laundry	0,5
Non-mechanical drying of laundry	1,5

**Table K.2 — Human activities and rate of moisture production**

Activity	Rate of production g/h
Seated, at rest	50
Seated, very light work	70
Seated, moderately active	90
Standing, light work or walking	90
Walking or standing	110
Seated, light work	200
Moderate dancing	240
Walking briskly with a load	270
Light exercise	380
Heavy work with lifting	420
Athletics	470

**Table K.3 — Moisture source events and moisture production per event**

Source event	Production per event g
Bath (15 min)	60
Shower (15 min)	660
Breakfast preparation	160 to 270
Lunch preparation	250 to 320
Dinner preparation	550 to 720
Breakfast dishes	100
Lunch dishes	70
Dinner dishes	310
Simmering pot (15 cm diameter, 10 min)	60
Boiling pot (15 cm diameter, 10 min)	260
Floor mopping (dried over one hour)	14
Non-vented cloth drier (per load)	2 130 to 2 900

## K.5 Moisture influx due to ventilation

The influx of water vapour to a room due to the air flow by natural and mechanical ventilation is calculated with Equation (K.2), which is similar to Equation (30) for determining the heat flow due to ventilation:

$$G_v = \frac{m_a}{\rho(v_{in} - v_i)} \quad (\text{K.2})$$

where

$G_v$  is the moisture influx by ventilation;

$m_a$  is the mass flow rate of dry air;

$\rho$  is the air density;

$v_{in}$  is the humidity by volume of the inflowing air;

$v_i$  is the humidity by volume of the internal air.

## Annex L (informative)

### Normative references to international publications with their corresponding European publications

This International Standard has been prepared under a mandate given to CEN by the European Commission and the European Free Trade Association (Mandate M/343), and supports essential requirements of EU Directive 2002/91/EC on the energy performance of buildings (EPBD). It forms part of a series of standards aimed at European harmonization of the methodology for the calculation of the energy performance of buildings. An overview of the whole set of standards is given in CEN/TR 15615, Explanation of the general relationship between various CEN standards and the Energy Performance of Buildings Directive (EPBD) ("Umbrella document").

The following referenced documents are indispensable for the application of this document. For dated references, only the edition cited applies. For undated references, the latest edition of the referenced document (including any amendments) applies.

Year	Publication	Title	EN	Year	Title
—	ISO 7345	Thermal insulation — Physical quantities and definitions	EN ISO 7345	—	Thermal insulation — Physical quantities and definitions
—	ISO 6946	Building components and building elements — Thermal resistance and thermal transmittance — Calculation method	EN ISO 6946	—	Building components and building elements — Thermal resistance and thermal transmittance — Calculation method
—	ISO 9050	Glass in building — Determination of light transmittance, solar direct transmittance, total solar energy transmittance, ultraviolet transmittance and related glazing factors	EN 410	—	Glass in building — Determination of luminous and solar characteristics of glazing
—	ISO 9251	Thermal insulation — Heat transfer conditions and properties of materials — Vocabulary (ISO 9251:1987)	EN ISO 9251	—	Thermal insulation — Heat transfer conditions and properties of materials — Vocabulary
—	ISO 9288	Thermal insulation — Heat transfer by radiation — Physical quantities and definitions	EN ISO 9288	—	Thermal insulation — Heat transfer by radiation — Physical quantities and definitions
—	ISO 9346	Hygrothermal performance of buildings and building materials — Physical quantities for mass transfer — Vocabulary	EN ISO 9346	—	Hygrothermal performance of buildings and building materials — Physical quantities for mass transfer — Vocabulary

Year	Publication	Title	EN	Year	Title
—	ISO 10077-1	Thermal performance of windows, doors and shutters — Calculation of thermal transmittance — Part 1: General	EN ISO 10077-1	—	Thermal performance of windows, doors and shutters — Calculation of thermal transmittance — Part 1: General
—	ISO 10077-2	Thermal performance of windows, doors and shutters — Calculation of thermal transmittance — Part 2: Numerical method for frames	EN ISO 10077-2	—	Thermal performance of windows, doors and shutters — Calculation of thermal transmittance — Part 2: Numerical method for frames
—	ISO 10292	Glass in building — Calculation of steady-state U values (thermal transmittance) of multiple glazing	EN 673	—	Glass in building — Determination of thermal transmittance (U value) — Calculation method
—	ISO 13370	Thermal performance of buildings — Heat transfer via the ground — Calculation methods	EN ISO 13370	—	Thermal performance of buildings — Heat transfer via the ground — Calculation methods
—	ISO 15927-2	Hygrothermal performance of buildings — Calculation and presentation of climatic data — Part 2: Hourly data for design cooling load	EN ISO 15927-2	—	Hygrothermal performance of buildings — Calculation and presentation of climatic data — Part 2: Hourly data for design cooling load

## Bibliography

- [1] ALAMDARI, F. and HAMMOND, G.P. *Improved data correlations for buoyancy driven convection in rooms*. Building Services Engineering Research & Technology, Vol. 4, no. 3, 1983, pp. 106-112
- [2] BLAND, BH. and PINNEY, A. *Conduction a review of theoretical treatments and validation of thermal models*. Vol. II, part 4 of the final report for the BRE/SERC, Garston (UK), December 1988
- [3] CARSLAW, H.S. et al. *Conduction of heat in solids*. 2nd Edition, Clarendon Press, London (UK), 1959
- [4] CLARKE, J.A. *Energy Implications in Building Design: A Thermal Simulation Design Model*. Abacus Dept. of Architecture and Building Science, University of Strathclyde, Glasgow, Scotland (UK)
- [5] CLARKE, J.A. *ESP A Building and Plant Energy Simulation System*. Abacus Publication, University of Strathclyde, Glasgow, Scotland (UK), 10/1987
- [6] KEEBLE, E. and AHMED, Z. *Commentary on Methods of Selecting Climate Data for Assessing Risk of Overheating in Naturally Ventilated Buildings*. BRE, Garston (UK), 1991
- [7] KUSUDA, T. *NBSLD The Computer program for load determination*. NBS BS 69, 1976
- [8] MC ADAMS. *Heat transmission*. McGraw Hill Book Ed., New York (USA), 1954
- [9] MITALAS, G.P. and STEPHENSON, DG. *Fortran IV programs for calculating radiant energy interchange factors*. DBR Computer Program, NRC N.25, 1966
- [10] STEFANIZZI, P., WILSON, A. and PINNEY, A. *A comparative study of methods for calculating internal long wave radiation exchanges in buildings*. BRE Garston, Watford (UK), 1990
- [11] STEPHENSON, D.G. and MITALAS, G.P. *Calculation of heat conduction transfer functions for multi-layer slabs*. ASHRAE Transactions, Vol. 77, Part II, 1971
- [12] TSEN-YAO SUN. *Shadow area equations for window overhangs and side fins and their application in computer calculation*. ASHRAE Semiannual meeting, Ohio (USA), Paper nr 2059, 1968
- [13] VOIT, P. *Suggestions for the improvement of the external longwave radiation prediction by ESP*. ITW University Stuttgart (Germany), PASSYS doc n.88-MVD-9 4/1988
- [14] WALTON, G.N. *A new algorithm for radiant interchange in room loads calculations*. ASHRAE Transactions, Vol. 86, part 2, 1980
- [15] IEA ANNEX41 “*Whole building heat, air and moisture transport (MOIST-ENG)*”, Final Report, Subtask 1, April 2008
- [16] IEA ANNEX41 “*Whole building heat, air and moisture transport (MOIST-ENG)*”, Final Report, Subtask 3, April 2008



Copyright International Organization for Standardization

---

---

**ICS 91.120.10**

Price based on 96 pages