**Thermal performance of buildings —
Transmission and ventilation heat
transfer coefficients — Calculation
method**

*Performance thermique des bâtiments — Coefficients de transfert
thermique par transmission et par renouvellement d'air — Méthode de
calcul*



Reference number
ISO 13789:2007(E)

© ISO 2007

PDF disclaimer

This PDF file may contain embedded typefaces. In accordance with Adobe's licensing policy, this file may be printed or viewed but shall not be edited unless the typefaces which are embedded are licensed to and installed on the computer performing the editing. In downloading this file, parties accept therein the responsibility of not infringing Adobe's licensing policy. The ISO Central Secretariat accepts no liability in this area.

Adobe is a trademark of Adobe Systems Incorporated.

Details of the software products used to create this PDF file can be found in the General Info relative to the file; the PDF-creation parameters were optimized for printing. Every care has been taken to ensure that the file is suitable for use by ISO member bodies. In the unlikely event that a problem relating to it is found, please inform the Central Secretariat at the address given below.



COPYRIGHT PROTECTED DOCUMENT

© ISO 2007

All rights reserved. Unless otherwise specified, no part of this publication may be reproduced or utilized in any form or by any means, electronic or mechanical, including photocopying and microfilm, without permission in writing from either ISO at the address below or ISO's member body in the country of the requester.

ISO copyright office
Case postale 56 • CH-1211 Geneva 20
Tel. + 41 22 749 01 11
Fax + 41 22 749 09 47
E-mail copyright@iso.org
Web www.iso.org

Published in Switzerland

Contents

Page

Foreword	iv
Introduction	v
1 Scope	1
2 Normative references	1
3 Terms and definitions	2
4 Transmission heat transfer coefficient	4
5 Ventilation heat transfer coefficient	7
6 Transmission heat transfer coefficient through unconditioned spaces	7
7 Heat transfer to adjacent buildings	8
8 Additional conventions	8
9 Report	10
Annex A (normative) Temperature in an unconditioned space	11
Annex B (informative) Information on type of dimensions	12
Annex C (informative) Ventilation airflow rates	14
Bibliography	18

Foreword

ISO (the International Organization for Standardization) is a worldwide federation of national standards bodies (ISO member bodies). The work of preparing International Standards is normally carried out through ISO technical committees. Each member body interested in a subject for which a technical committee has been established has the right to be represented on that committee. International organizations, governmental and non-governmental, in liaison with ISO, also take part in the work. ISO collaborates closely with the International Electrotechnical Commission (IEC) on all matters of electrotechnical standardization.

International Standards are drafted in accordance with the rules given in the ISO/IEC Directives, Part 2.

The main task of technical committees is to prepare International Standards. Draft International Standards adopted by the technical committees are circulated to the member bodies for voting. Publication as an International Standard requires approval by at least 75 % of the member bodies casting a vote.

Attention is drawn to the possibility that some of the elements of this document may be the subject of patent rights. ISO shall not be held responsible for identifying any or all such patent rights.

ISO 13789 was prepared by Technical Committee ISO/TC 163, *Thermal performance and energy use in the built environment*, Subcommittee SC 2, *Calculation methods*.

This second edition cancels and replaces the first edition (ISO 13789:1999) which has been technically revised.

A summary of the principal changes is given below.

- The title has been replaced by "...Transmission and ventilation heat transfer coefficients — ..." This is because a ventilation coefficient has been added (see Clause 5) and "loss" is replaced by "transfer" to allow for cases of cooling.
- Consequential changes have also been made in the Introduction, Scope and elsewhere throughout this International Standard.
- In Clause 2, reference is to "ISO" rather than to "EN ISO" where applicable. ISO 10077-2 has been added.
- In 4.3, the text has been clarified and Note 1 added.
- 4.4 and 4.5 have been amended to say that heat transfer to/from unheated spaces via the ground is disregarded.
- Clause 5 This is a new clause, taken unchanged from 7.3 of ISO 13790. The intention is that 7.3 of ISO 13790 should be deleted when that International Standard is revised and replaced by a reference to ISO 13789.
- Annex C is a new annex, taken unchanged from Annex G of ISO 13790. The intention is that Annex G of ISO 13790 should be deleted when that International Standard is revised.

Introduction

The aims of this International Standard are

- a) to clarify the international market through the harmonized definition of intrinsic characteristics of buildings;
- b) to help in judging compliance with regulations;
- c) to provide input data for calculation of annual energy use for heating or cooling buildings.

The result of the calculations can be used as input for calculation of annual energy use and heating or cooling load of buildings, for expressing the thermal transmission and/or ventilation characteristics of a building or for judging compliance with specifications expressed in terms of transmission and/or ventilation heat transfer coefficients.

This International Standard provides the means (in part) to assess the contribution that building products and services make to energy conservation and to the overall energy performance of buildings.

Thermal performance of buildings — Transmission and ventilation heat transfer coefficients — Calculation method

1 Scope

This International Standard specifies a method and provides conventions for the calculation of the steady-state transmission and ventilation heat transfer coefficients of whole buildings and parts of buildings. It is applicable both to heat loss (internal temperature higher than external temperature) and to heat gain (internal temperature lower than external temperature). For the purpose of this International Standard, the heated or cooled space is assumed to be at uniform temperature.

Annex A provides a steady-state method to calculate the temperature in unconditioned spaces adjacent to conditioned spaces.

2 Normative references

The following referenced documents are indispensable for the application of this document. For dated references, only the edition cited applies. For undated references, the latest edition of the referenced document (including any amendments) applies.

ISO 6946¹⁾, *Building components and building elements — Thermal resistance and thermal transmittance — Calculation method*

ISO 7345, *Thermal insulation — Physical quantities and definitions*

ISO 10077-1, *Thermal performance of windows, doors and shutters — Calculation of thermal transmittance — Part 1: General*

ISO 10077-2, *Thermal performance of windows, doors and shutters — Calculation of thermal transmittance — Part 2: Numerical method for frames*

ISO 10211²⁾, *Thermal bridges in building construction — Heat flows and surface temperatures — Detailed calculations*

ISO 13370³⁾, *Thermal performance of buildings — Heat transfer via the ground — Calculation methods*

ISO 14683⁴⁾, *Thermal bridges in building construction — Linear thermal transmittance — Simplified methods and default values*

EN 15242⁵⁾, *Ventilation for buildings — Calculation methods for the determination of air flow rates in buildings including infiltration*

-
- 1) To be published (revision of ISO 6946:1996).
 - 2) To be published (revision of ISO 10211-1:1995 and ISO 10211-2:2001).
 - 3) To be published (revision of ISO 13370:1998).
 - 4) To be published (revision of ISO 14683:1999).
 - 5) To be published.

3 Terms and definitions

3.1 Terms and definitions

For the purposes of this document, the terms and definitions in ISO 7345 and the following apply.

3.1.1

heated space

room or enclosure that, for the purposes of a calculation, is assumed to be heated to a given set-point temperature or set point temperatures

3.1.2

cooled space

room or enclosure that, for the purposes of a calculation, is assumed to be cooled to a given set-point temperature or set-point temperatures

3.1.3

conditioned space

heated and/or cooled space

NOTE The heated and/or cooled spaces are used to define the thermal envelope.

3.1.4

unconditioned space

room or enclosure which is not part of a conditioned space

3.1.5

heat transfer coefficient

heat flow rate divided by temperature difference between two environments; specifically used for heat transfer coefficient by transmission or ventilation

3.1.6

transmission heat transfer coefficient

heat flow rate due to thermal transmission through the fabric of a building, divided by the difference between the environment temperatures on either side of the construction

NOTE By convention, if the heat is transferred between a conditioned space and the external environment, the sign is positive if the heat flow is from the space to outside (heat loss).

3.1.7

ventilation heat transfer coefficient

heat flow rate due to air entering a conditioned space either by infiltration or ventilation, divided by the temperature difference between the internal air and the supply air temperature

NOTE The supply temperature for infiltration is equal to the external temperature.

3.1.8

building heat transfer coefficient

sum of transmission and ventilation heat transfer coefficients

3.1.9

internal dimension

dimension measured from wall to wall and floor to ceiling inside a room of a building

NOTE See Figure 1.

3.1.10

overall internal dimension

dimension measured on the interior of a building, ignoring internal partitions

NOTE See Figure 1.

3.1.11

external dimension

dimension measured on the exterior of a building

NOTE See Figure 1.

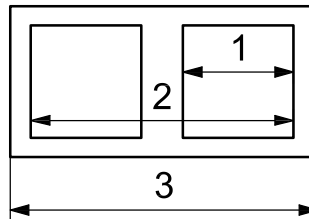

Key

- 1 internal dimension
- 2 overall internal dimension
- 3 external dimension

Figure 1 — Dimension systems

3.2 Symbols and units

Symbol	Quantity	Unit
A	Area	m ²
b	Adjustment factor for heat transfer coefficient	—
c_p	Specific heat capacity of air at constant pressure	Wh/(kg·K)
H	Heat transfer coefficient	W/K
U	Thermal transmittance	W/(m ² ·K)
\dot{V}	Volumetric air flow rate	m ³ /h
l	Length	m
n	Air change rate	h ⁻¹
ρ	Density	kg/m ³
Ψ	Linear thermal transmittance	W/(m·K)
χ	Point thermal transmittance	W/K

4 Transmission heat transfer coefficient

4.1 Basic equation

The transmission heat transfer coefficient, H_T , is calculated according to Equation (1):

$$H_T = H_D + H_g + H_U + H_A \quad (1)$$

where

H_D is the direct heat transfer coefficient between the heated or cooled space and the exterior through the building envelope, defined by Equation (2), in W/K;

H_g is the steady-state ground heat transfer coefficient defined in 4.4, in W/K;

H_U is the transmission heat transfer coefficient through unconditioned spaces defined in Equation (5), in W/K;

H_A is the transmission heat transfer coefficient to adjacent buildings, determined according to Clause 7, in W/K.

ISO 10211 gives a general procedure for the calculation of the total thermal coupling coefficient of the complete envelope or any part of it, including ground heat transfer. Where no unconditioned space is involved, the total thermal coupling coefficient corresponds to the transmission heat transfer coefficient as defined in this International Standard.

NOTE In some applications the heat transfer via the ground is treated in terms of a constant part related to the annual average temperature difference and a varying part related to the monthly variations of internal and external temperature difference.

4.2 Boundaries of conditioned space

Before calculation, the conditioned space of the building under consideration shall be clearly defined. The building elements considered in the calculations are the boundaries of the spaces that are heated or cooled (directly or indirectly).

The building envelope above ground is modelled by plane and beam-shaped elements as shown on Figure 2.

Boundaries between the “underground” part, involving heat transmission through the ground, and the “above-ground” part of the building, having direct heat transfer to the external environment or to unconditioned spaces, are, according to ISO 13370,

- for buildings with slab-on-ground floors, suspended floors and unheated basements: the level of the internal surface of the ground floor (excluding any floor coverings such as carpets);
- for buildings with a heated basement: the external ground level.

Annex B provides information on the effect of using various types of dimensions when dividing the envelope into elements.

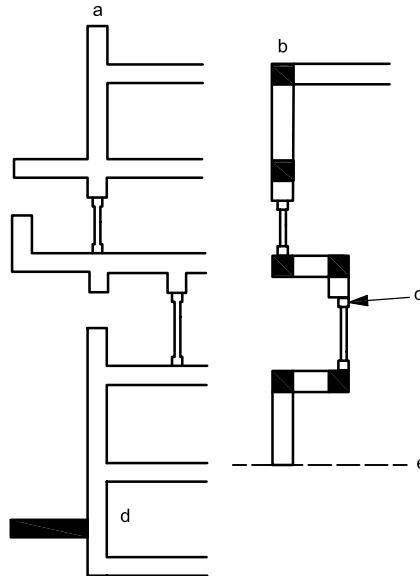

Key



-  flat envelope elements: ISO 6946 is applicable
-  windows and doors, with their frames: ISO 10077-1 and ISO 10077-2 are applicable
-  potential thermal bridges: ISO 14683 or ISO 10211 are applicable
- a Reality.
- b Model.
- c Window/wall junctions that are also potential thermal bridges.
- d Unheated.
- e Application limit of ISO 13370.

Figure 2 — Modelling the building envelope by plane and beam-shaped components

If calculations are performed for parts of buildings, the boundaries of these parts shall be clearly defined, so that the sum of the transmission heat transfer coefficients of all parts equals that of the building.

4.3 Direct transmission between internal and external environments

The transmission heat transfer coefficient through the building elements separating the conditioned space and the external air is calculated either directly by numerical methods according to ISO 10211 or according to Equation (2):

$$H_D = \sum_i A_i U_i + \sum_k l_k \Psi_k + \sum_j \chi_j \quad (2)$$

where

- A_i is the area of element i of the building envelope, in m^2 [the dimensions of windows and doors are taken as the dimensions of the aperture in the wall ⁶⁾];
- U_i is the thermal transmittance of element i of the building envelope, in $W/(m^2 \cdot K)$;
- l_k is the length of linear thermal bridge k , in m ;
- Ψ_k is the linear thermal transmittance of thermal bridge k , taken from tables or catalogues prepared in accordance with ISO 14683 or calculated according to ISO 10211, in $W/(m \cdot K)$;
- χ_j is the point thermal transmittance of point thermal bridge j , calculated according to ISO 10211, in W/K (point thermal bridges which are normally part of plane building elements and already taken into account in their thermal transmittance shall not be added here).

The summation shall be done over all the building components separating the internal and the external environments.

The thermal transmittance, U , shall be calculated by a method that is appropriate for the element concerned. Simplified methods are given in ISO 6946 and ISO 10077-1. Detailed methods are given in ISO 10211 and ISO 10077-2⁷⁾. The coefficient of thermal transmission can equally be determined by measurement in accordance with ISO 12567-1 or ISO 12567-2.

When the main insulation layer is continuous and of uniform thickness, the linear and point thermal transmittances may be neglected if external dimensions are used. The main insulation layer is the layer with the highest thermal resistance in the elements flanking the potential thermal bridge. Corrections for other cases may be defined on a national basis.

For existing buildings typical values can be given on a national basis for different construction types, for use when accurate values cannot be ascertained with reasonable effort.

4.4 Transmission heat transfer coefficient through the ground

The coefficient for heat transfer via the ground, H_g , is calculated according to ISO 13370. If there are unconditioned spaces (see Clause 6), H_g is calculated as if the unconditioned spaces were not present.

ISO 13370 provides methods for calculating the heat transfer coefficient on a monthly basis, $H_{g,m}$, taking account of the thermal inertia of the ground. These monthly coefficients may be related to the annual average coefficient, H_g , by adjustment factors, b_m , where for each month m

$$b_m = \frac{H_{g,m}}{H_g} \quad (3)$$

Values of b_m may be set at the national level on a monthly or seasonal basis.

NOTE The value of b is typically less than 1 in winter and greater than 1 in summer, because during winter the effective temperature difference through the ground is smaller than the temperature difference between the internal and external environments, and in summer it is higher. If the average monthly external temperature is higher than the internal temperature the value of b can be negative.

6) The area of the window, as used to establish the thermal transmittance of the window, can be slightly larger than the aperture in the wall. The effect of any differences in area is incorporated in the values of Ψ_k for the junctions between walls and window.

7) EN 13947 gives methods for curtain walling.

5 Ventilation heat transfer coefficient

The ventilation heat transfer coefficient, H_V , is calculated from Equation (4):

$$H_V = \rho_a c_p \dot{V} \quad (4)$$

where

\dot{V} is the airflow rate through the heated or cooled space;

$\rho_a c_p$ is the heat capacity of air per volume.

If the air flow rate, \dot{V} , is in m³/s, $\rho_a c_p = 1\,200 \text{ J}/(\text{m}^3 \cdot \text{K})$. If \dot{V} is given in m³/h, $\rho_a c_p = 0,33 \text{ Wh}/(\text{m}^3 \cdot \text{K})$.

The airflow rate, \dot{V} , may be calculated according to the documents in Table 1 or provided at the national level based on the type of buildings, building use, climate, exposure, etc.

Table 1 — Methods for obtaining airflow rates

Countries whose national standards body is a member of CEN	Elsewhere
According to EN 15242	According to Annex C of this International Standard, national standards or other appropriate documents

6 Transmission heat transfer coefficient through unconditioned spaces

The transmission heat transfer coefficient, H_U , between a conditioned space and the external environments via unconditioned spaces is obtained from Equation (5):

$$H_U = H_{iu} b \quad \text{with} \quad b = \frac{H_{ue}}{H_{iu} + H_{ue}} \quad (5)$$

where

H_{iu} is the direct heat transfer coefficient between the conditioned space and the unconditioned space, calculated according to 4.3, in W/K;

H_{ue} is the heat transfer coefficient between the unconditioned space and the external environment, in W/K.

NOTE 1 In Equation (5), the adjustment factor, b , allows for the unconditioned space being at a different temperature to the external environment (see Annex A). The conditioned space is assumed to be at a uniform temperature.

NOTE 2 Heat transmission through the ground is not included in either H_{iu} or H_{ue} .

H_{iu} and H_{ue} include the transmission and ventilation heat transfers. They are calculated according to Equation (6):

$$H_{iu} = H_{T,iu} + H_{V,iu} \quad \text{and} \quad H_{ue} = H_{T,ue} + H_{V,ue} \quad (6)$$

ISO 13789:2007(E)

The transmission coefficients, $H_{T,ue}$ and $H_{T,iu}$ are calculated according to 4.3 and the ventilation heat transfer coefficients, $H_{V,ue}$ and $H_{V,iu}$, by Equation (7):

$$H_{V,iu} = \rho c_p \dot{V}_{iu} \quad \text{and} \quad H_{V,ue} = \rho c_p \dot{V}_{ue} \quad (7)$$

where

ρ is the density of air, in kg/m³;

c_p is the specific heat capacity of air, in Wh/(kg·K);

\dot{V}_{ue} is the air flow rate between the unconditioned space and the external environment, in m³/h;

\dot{V}_{iu} is the air flow rate between the conditioned and unconditioned spaces, in m³/h.

NOTE 3 ISO 6946 provides approximate methods for some particular unheated spaces.

7 Heat transfer to adjacent buildings

Where the heat transfer to an adjacent building, at a temperature different from that of the building under consideration, is to be taken into account, the heat transfer coefficient between the two buildings is obtained using Equation (8):

$$H_A = b H_{ia} \quad (8)$$

where

H_{ia} is the direct heat transfer coefficient between the conditioned space and the adjacent building.

$$b = \frac{\theta_i - \theta_a}{\theta_i - \theta_e} \quad (9)$$

where

θ_i is the internal temperature of the building under consideration;

θ_a is the temperature of the adjacent building;

θ_e is the external temperature;

NOTE The value of b can be negative.

8 Additional conventions

8.1 General

If the purpose of the calculation is to provide data for estimation of annual energy requirement, the best available data should be used as input for the calculations.

If the purpose is to express the thermal-transmission and/or ventilation characteristics of a building considered as a product or for judging compliance with specifications expressed in terms of the thermal-transmission and/or ventilation coefficient, the values defined in 8.2 to 8.4 shall be used. The result of the calculations is then independent of location and use of the building.

8.2 Transmission heat transfer coefficient through the ground

This coefficient is the steady-state component, H_g , calculated according to ISO 13370, the thermal conductivity of the ground being taken as 2 W/(m·K).

8.3 Variable thermal transmittance

Where thermal transmittance can vary, the maximum value shall be used.

8.4 Air change rates of unconditioned spaces

In order not to underestimate the transmission heat transfer, the air flow rate between a conditioned space and an unconditioned space shall be assumed to be zero:

$$\dot{V}_{iu} = 0 \quad (10)$$

The air flow rate between the unheated space and the external environment is calculated according to Equation (11):

$$\dot{V}_{ue} = V_u n_{ue} \quad (11)$$

where

n_{ue} is the conventional air change rate between the unconditioned space and the external environment, in h^{-1} ;

V_u is the volume of air in the unconditioned space, in m^3 .

The air change rate, n_{ue} , is the value from Table 1 which best corresponds to the unconditioned space under consideration.

Table 2 — Conventional air change rates between the unconditioned space and the external environment

No	Air tightness type	n_{ue} h^{-1}
1	No doors or windows, all joints between components well-sealed, no ventilation openings provided	0,1
2	All joints between components well-sealed, no ventilation openings provided	0,5
3	All joints well-sealed, small openings provided for ventilation	1
4	Not airtight due to some localised open joints or permanent ventilation openings	3
5	Not airtight due to numerous open joints, or large or numerous permanent ventilation openings	10

NOTE If the air change at 50 Pa, n_{50} , or the equivalent leakage area, A_l , is known, the air change rate, n , can be estimated by one of the following empirical relations:

$$n = \frac{n_{50}}{20} \quad \text{or} \quad n = \frac{A_l}{10 V_u} \quad (12)$$

where A_l is expressed in cm^2 and V_u is expressed in m^3 .

Then the value in Table 1 that is the closest to n is taken for n_{ue} .

The conventional value for heat capacity of air is $\rho c_p = 1\,200 \text{ J}/(\text{m}^3 \cdot \text{K})$ [or $0,33 \text{ Wh}/(\text{m}^3 \cdot \text{K})$].

9 Report

The report shall contain the following information:

- a) reference to this International Standard (ISO 13789:2007);
- b) identification of the building;
- c) plans of the building, with the assumed boundaries of the heated or cooled space marked on it;
- d) description of the components of the building envelope, that is their elements including dimensions and the materials used;
- e) a list of these components, with their areas and surface thermal transmittances, the lengths and linear transmittances of linear thermal bridges as well as the number and point thermal transmittances of point thermal bridges;
- f) if there are unconditioned spaces, the assumed air-change rates;
- g) transmission heat transfer coefficients to the exterior, H_D , through the ground, H_g , and through unconditioned spaces, H_U , rounded to three significant figures;
- h) total transmission heat transfer coefficient, H_T , rounded to three significant figures;
- i) ventilation heat transfer coefficient, H_V , rounded to three significant figures;
- j) if variable thermal transmittances are taken into account, results for both maximum and minimum values shall be given, together with the description of the varied thermal transmittances and their extreme values.

Annex A (normative)

Temperature in an unconditioned space

This temperature is calculated assuming steady-state conditions. It results from a steady-state heat balance in the unconditioned space and is calculated according to Equation (A.1):

$$\theta_u = \frac{\Phi + \theta_i H_{iu} + \theta_e H_{ue}}{H_{iu} + H_{ue}} \quad (\text{A.1})$$

where

θ is a temperature;

Φ is the heat flow rate generated within the unconditioned space (e.g. solar gains);

H are the heat transfer coefficients calculated according to Clause 4 of this International Standard;

The subscript “i” is for internal, “e” is for external, and “u” is for unconditioned.

NOTE Calculation of the temperature in an unconditioned space is not necessary for the use of this International Standard, but is required by other standards. Since it can be directly deduced from results of this International Standard, the method is given here.

Annex B (informative)

Information on type of dimensions

To apply the calculation method, the building envelope is divided into elements (see Clause 4 and Figure B.1). However, building-element dimensions are usually measured according to one of three systems: internal, overall internal, and external. These differ in the way that the flat areas of junctions between elements are included in the areas of these elements themselves.

Thus, for example, the term $\sum_i A_i U_i$ in Equation (2) is larger when using external dimensions than when using internal dimensions. Consequently, the values of Ψ_k are generally smaller for external dimensions, and can even be negative in some cases such as external corners.

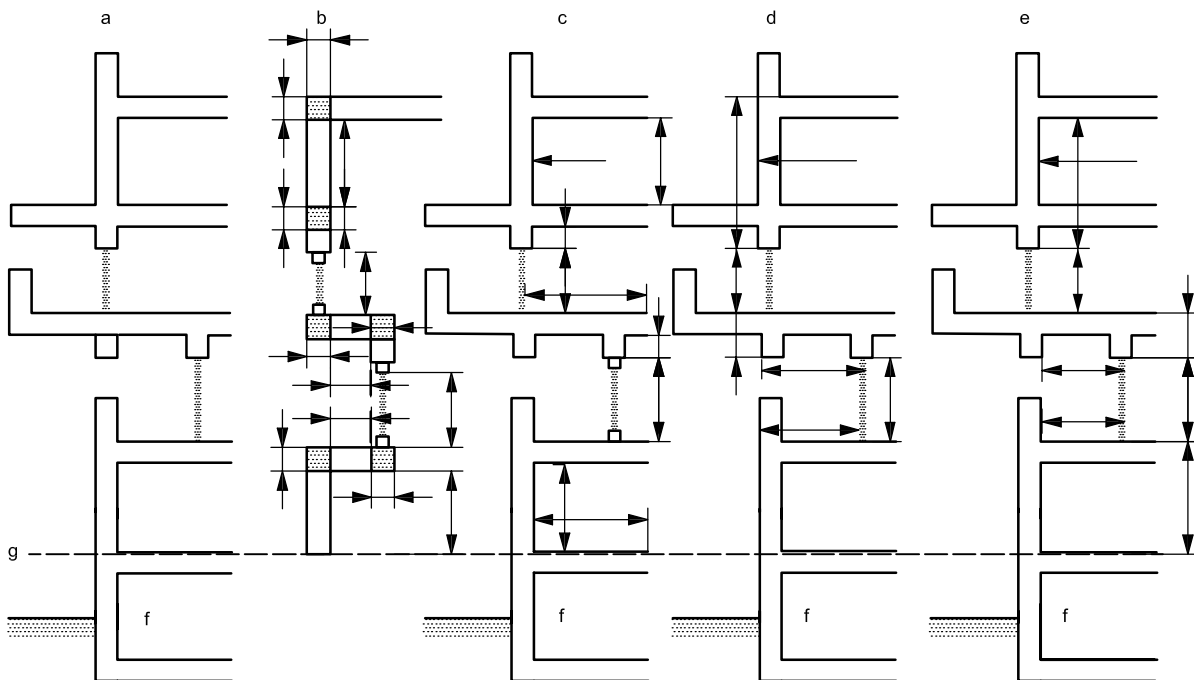

- a Reality.
- b Elements.
- c Internal dimensions.
- d External dimensions.
- e Overall internal dimensions.
- f Unheated.
- g ISO 13370 applies to heat transfers below this boundary.

NOTE 1 For a heated basement, dimensions are measured to the basement floor slab.

NOTE 2 External dimensions can also be measured to the bottom of the floor slab.

Figure B.1 — Examples of methods for determining building element dimensions

When the principal insulation layer is continuous, the linear thermal transmittance of some junctions can be small, particularly when external or overall internal dimensions are used. They are often neglected in those cases. As a consequence, slight differences in the calculated values of the transmission heat transfer coefficient can arise between dimension systems, if certain thermal bridges are neglected under one system but not under another one.

Therefore, it is recommended, in particular in case of dispute, that the building is assessed using the dimensions of each individual element (second left in Figure B.1). In this method, the linear thermal transmittance of each junction is explicitly included.

Annex C (informative)

Ventilation airflow rates

C.1 General

Unless otherwise specified in International Standards or in national provisions, this annex can be used to calculate the airflow rate in buildings.

C.2 Air tightness level

The tightness level is defined from ranges of the air change rate at 50 Pa pressure difference between indoor and outdoor, n_{50} , according to Table C.1. n_{50} includes air flow rates through closed air inlets.

Table C.1 — Air tightness levels as used in this annex

Air change rate at 50 Pa n_{50} h^{-1}		Envelope tightness level
Multi-family buildings	Single-family buildings	
Fewer than 2	Fewer than 4	High
2 to 5	4 to 10	Medium
More than 5	More than 10	Low

NOTE 1 The difference between multi-family and single-family buildings is related to the typical difference in their external wall areas for a given internal volume.

NOTE 2 In residential buildings with n_{50} less than $3 h^{-1}$ (with open air inlets), minimum ventilation requires opening windows at appropriate intervals.

C.3 Minimum ventilation rate

For comfort and hygienic reasons a minimum ventilation rate is needed when the building is occupied. This minimum ventilation rate can be determined on a national basis, taking account of the building type and the pattern of occupancy for the building.

Typical values are

$$\dot{V}_{\min} = 0,3 \times V \text{ [m}^3\text{/h]}, \text{ where } V \text{ is the ventilated volume in m}^3\text{, for residential buildings;}$$

$$\dot{V}_{\min} = 30 \text{ m}^3\text{/h per person (during occupancy) for non-residential buildings.}$$

C.4 Natural ventilation

C.4.1 Total ventilation rate

The total ventilation rate is determined as the greater of the minimum ventilation rate, \dot{V}_{\min} , and the design ventilation rate, \dot{V}_d :

$$\dot{V} = \max[\dot{V}_{\min}; \dot{V}_d] \tag{C.1}$$

where

\dot{V}_{\min} is the minimum ventilation rate;

\dot{V}_d is the design ventilation rate.

\dot{V}_d should be specified on a national basis. Where no national information is available, the air change rate in residential buildings may be assessed from Table C.2 or Table C.3.

C.4.2 Data for estimation of natural ventilation

The ventilation rate by natural ventilation can be determined on a national basis, taking into account the climate, the surroundings, the building type and geometry, and the size and the position of the openings. Where no national information is available, the monthly average ventilation rate during the heating season may be taken from Table C.2 or Table C.3.

Table C.2 — Air change rate, n , as a function of shielding class and building tightness — Naturally ventilated multi-family buildings

Dimensions in h^{-1}

Shielding class ^a	Air change rate n for more than one exposed facade			Air change rate n for only one exposed facade		
	Tightness of building			Tightness of building		
	Low	Medium	High	Low	Medium	High
No shielding	1,2	0,7	0,5	1,0	0,6	0,5
Moderate	0,9	0,6	0,5	0,7	0,5	0,5
Heavy shielding	0,6	0,5	0,5	0,5	0,5	0,5

^a Shielding classes are defined in Table C.4.

Table C.3 — Air change rate, n , as a function of shielding class and building tightness — Naturally ventilated single-family buildings

Dimensions in h^{-1}

Shielding class	Air change rate n Tightness of building		
	Low	Medium	High
No shielding	1,5	0,8	0,5
Moderate	1,1	0,6	0,5
Heavy shielding	0,7	0,5	0,5

C.5 Mechanical ventilation systems

The total airflow rate is determined as the sum of the ventilation rate determined from the average airflow rates through the system fans when in operation, \dot{V}_f , and an additional airflow rate, \dot{V}_x , induced by wind effects through ventilation openings and infiltration cracks according to Equation (C.2):

$$\dot{V} = \dot{V}_f + \dot{V}_x \tag{C.2}$$

where

\dot{V}_f is the average airflow rate through the system fans when in operation;

\dot{V}_x is the additional airflow rate with fans on, due to wind effects.

For supply-only systems, \dot{V}_f is equal to the supply airflow rate, \dot{V}_1 , and for exhaust only systems it is equal to the exhaust flow rate, \dot{V}_2 .

For balanced ventilation systems, \dot{V}_f is equal to the greater of the supply airflow rate, \dot{V}_1 , and the exhaust airflow rate, \dot{V}_2 .

The additional airflow rate, \dot{V}_x , can be calculated according to Equation (C.3):

$$\dot{V}_x = \frac{V n_{50} e}{1 + \frac{f}{e} \left[\frac{\dot{V}_1 - \dot{V}_2}{V n_{50}} \right]^2} \tag{C.3}$$

where

V is the ventilated volume;

n_{50} is the air change rate resulting from a pressure difference of 50 Pa between inside and outside, including the effects of air inlets;

\dot{V}_1 is the supply airflow rate;

\dot{V}_2 is the exhaust airflow rate;

e, f are shielding coefficients, which can be found in Table C.4.

NOTE Equation (C.3) is empirical, derived from numerical simulations over complete years. It is based on additional flow when there are large wind-induced pressure differences, assuming no additional flow for lower wind speeds.

Table C.4 — Shielding coefficients, e and f , for calculation of the additional air flow rate using Equation (C.3)

Shielding class	Description	Coefficient	More than one exposed facade	One exposed facade
No shielding	Buildings in open country, high rise buildings in city centres	e	0,10	0,03
Moderate shielding	Buildings in the country with trees or other buildings around them, suburbs		0,07	0,02
Heavy shielding	Buildings of average height in city centres, buildings in forests		0,04	0,01
All shielding classes	All types of buildings	f	15	20

If there is mechanical ventilation switched on for a part of the time, the airflow rate is calculated according to Equation (C.4):

$$\dot{V} = (\dot{V}_0 + \dot{V}'_x)(1 - \beta) + (\dot{V}_f + \dot{V}_x)\beta \quad (\text{C.4})$$

where

\dot{V}_f is the average airflow rate through the system fans when in operation;

\dot{V}_x is the additional airflow rate with fans on, due to wind effects;

\dot{V}_0 is the airflow rate with natural ventilation, including airflow through ducts of the mechanical system;

\dot{V}'_x is the additional airflow rate with fans off, due to wind effects: $\dot{V}'_x = V n_{50} e$;

β is the fraction of the time period with fans on.

In non-residential buildings, mechanical ventilation systems can be off for a large part of the time. This is taken into account through the definition of different periods or through the evaluation of β . A poor evaluation of β or a poor definition of periods can lead to large errors in the results.

For mechanical systems with variable design airflow rate, \dot{V}_f is the average airflow rate through the fans during their running time.

C.6 Mechanical systems with heat exchangers

For buildings with heat exchange between exhaust air and supply air, the heat transfer by the mechanical ventilation is reduced by the factor $(1 - \eta_v)$ where η_v is the global efficiency of the heat recovery system. This efficiency is always smaller than the effectiveness of the heat exchanger itself. It should take account of differences between supply and extract airflow rates, heat losses from ductwork outside the conditioned space, leakage and infiltration through the building envelope, recirculation of air, and de-frosting of the heat exchanger.

The effective air flow rate for the heat transfer calculation when fans are on is determined according to Equation (C.5):

$$\dot{V} = \dot{V}_f(1 - \eta_v) + \dot{V}_x \quad (\text{C.5})$$

where

\dot{V}_f is the design airflow rate due to mechanical ventilation;

\dot{V}_x is the additional airflow rate with fans on, due to wind effects;

η_v is the global heat recovery efficiency, taking account of the differences between supply and extract airflow rates. Heat in air leaving the building through leakage cannot be recovered.

For systems with heat recovery from the exhaust air to the hot water or space heating system via a heat pump, the ventilation rate is calculated without any reduction. Instead, the reduction in energy use due to heat recovery is allowed for in the calculation of the energy use of the relevant system.

Bibliography

- [1] ISO 12567-1, *Thermal performance of windows and doors — Determination of thermal transmittance by hot box method — Part 1: Complete windows and doors*
- [2] ISO 12567-2, *Thermal performance of windows and doors — Determination of thermal transmittance by hot box method — Part 2: Roof windows and other projecting windows*
- [3] EN 13947, *Thermal performance of curtain walling — Calculation of thermal transmittance*

.....

ICS 91.120.10

Price based on 18 pages