

First edition  
2012-07-01

---

---

**Ships and marine technology — Ship's  
mooring and towing fittings — Pedestal  
fairleads**

*Navires et technologie maritime — Corps-morts et ferrures de  
remorquage de navires — Chaumards à piédestal*



Reference number  
ISO 13776:2012(E)

© ISO 2012

.....



## COPYRIGHT PROTECTED DOCUMENT

© ISO 2012

All rights reserved. Unless otherwise specified, no part of this publication may be reproduced or utilized in any form or by any means, electronic or mechanical, including photocopying and microfilm, without permission in writing from either ISO at the address below or ISO's member body in the country of the requester.

ISO copyright office  
Case postale 56 • CH-1211 Geneva 20  
Tel. + 41 22 749 01 11  
Fax + 41 22 749 09 47  
E-mail [copyright@iso.org](mailto:copyright@iso.org)  
Web [www.iso.org](http://www.iso.org)

Published in Switzerland

<b>Contents</b>		Page
<b>Foreword</b> .....		<b>iv</b>
<b>Introduction</b> .....		<b>v</b>
<b>1</b>	<b>Scope</b> .....	<b>1</b>
<b>2</b>	<b>Normative references</b> .....	<b>1</b>
<b>3</b>	<b>Terms and definitions</b> .....	<b>1</b>
<b>4</b>	<b>Nominal sizes</b> .....	<b>1</b>
<b>5</b>	<b>Dimensions</b> .....	<b>1</b>
<b>6</b>	<b>Materials</b> .....	<b>1</b>
<b>7</b>	<b>Manufacturing and inspection</b> .....	<b>1</b>
<b>8</b>	<b>Marking</b> .....	<b>2</b>
<b>Annex A (informative) Basis for strength assessment of pedestal fairleads</b> .....		<b>6</b>
<b>Bibliography</b> .....		<b>8</b>

## Foreword

ISO (the International Organization for Standardization) is a worldwide federation of national standards bodies (ISO member bodies). The work of preparing International Standards is normally carried out through ISO technical committees. Each member body interested in a subject for which a technical committee has been established has the right to be represented on that committee. International organizations, governmental and non-governmental, in liaison with ISO, also take part in the work. ISO collaborates closely with the International Electrotechnical Commission (IEC) on all matters of electrotechnical standardization.

International Standards are drafted in accordance with the rules given in the ISO/IEC Directives, Part 2.

The main task of technical committees is to prepare International Standards. Draft International Standards adopted by the technical committees are circulated to the member bodies for voting. Publication as an International Standard requires approval by at least 75 % of the member bodies casting a vote.

Attention is drawn to the possibility that some of the elements of this document may be the subject of patent rights. ISO shall not be held responsible for identifying any or all such patent rights.

ISO 13776 was prepared by Technical Committee ISO/TC 8, *Ships and marine technology*, Subcommittee SC 4, *Outfitting and deck machinery*.

## Introduction

The pedestal fairlead is a type of ship's mooring fitting installed on board to lead and change the direction of mooring ropes.

© ISO 2012. All rights reserved.



# Ships and marine technology — Ship's mooring and towing fittings — Pedestal fairleads

## 1 Scope

This International Standard specifies the design, size and technical requirements for pedestal fairleads installed to lead the mooring rope of a ship.

## 2 Normative references

The following referenced documents are indispensable for the application of this document. For dated references, only the edition cited applies. For undated references, the latest edition of the referenced document (including any amendments) applies.

ISO 13755, *Ships and marine technology — Ship's mooring and towing fittings — Steel rollers*

IMO Circular MSC/Circ.1175, *Guidance on shipboard towing and mooring equipment*

## 3 Terms and definitions

For the purposes of this document, the following terms and definitions apply.

### 3.1

**safe working load**

**SWL**

maximum load in kN on the rope that should normally be applied in service conditions

## 4 Nominal sizes

The nominal sizes,  $D_n$ , of pedestal fairleads are denoted by reference to the outside diameter of the roller in millimetres from a basic series of preferred numbers.

The nominal sizes are: 150, 200, 250, 300, 350, 400, 450 and 500.

## 5 Dimensions

Pedestal fairleads have dimensions and particulars in accordance with Table 1, and Figures 1 and 2.

## 6 Materials

The following material shall be used for manufacturing the pedestal fairleads:

— Pedestal: weldable steel plates having a yield point of not less than 235 N/mm<sup>2</sup>.

## 7 Manufacturing and inspection

**7.1** All surfaces of the pedestal fairleads, including welding, shall be free from any visible flaws or imperfections.

**7.2** All surfaces in contact with the ropes shall be free from surface roughness or irregularities likely to cause damage to the ropes by abrasion.

7.3 The pedestal fairleads shall be coated externally with an anti-corrosion protective finish.

## 8 Marking

8.1 The safe working load (SWL) intended for the use of the pedestal fairleads shall be noted in the towing and mooring plan available on board for the guidance of the shipmaster as specified in MSC/Circ.1175.

8.2 The actual SWL on board shall be determined by considering the under deck reinforcement, and shall be marked on the towing and mooring plan. The actual SWL shall not be over the SWL indicated in this International Standard.

8.3 The pedestal fairleads shall be clearly marked with their SWL by weld bead or equivalent. The SWL shall be expressed in tonnes (letter 't') and be placed so that it is not obscured during operation of the fitting.

EXAMPLE SWL XXX t

.....



Dimensions in millimetres

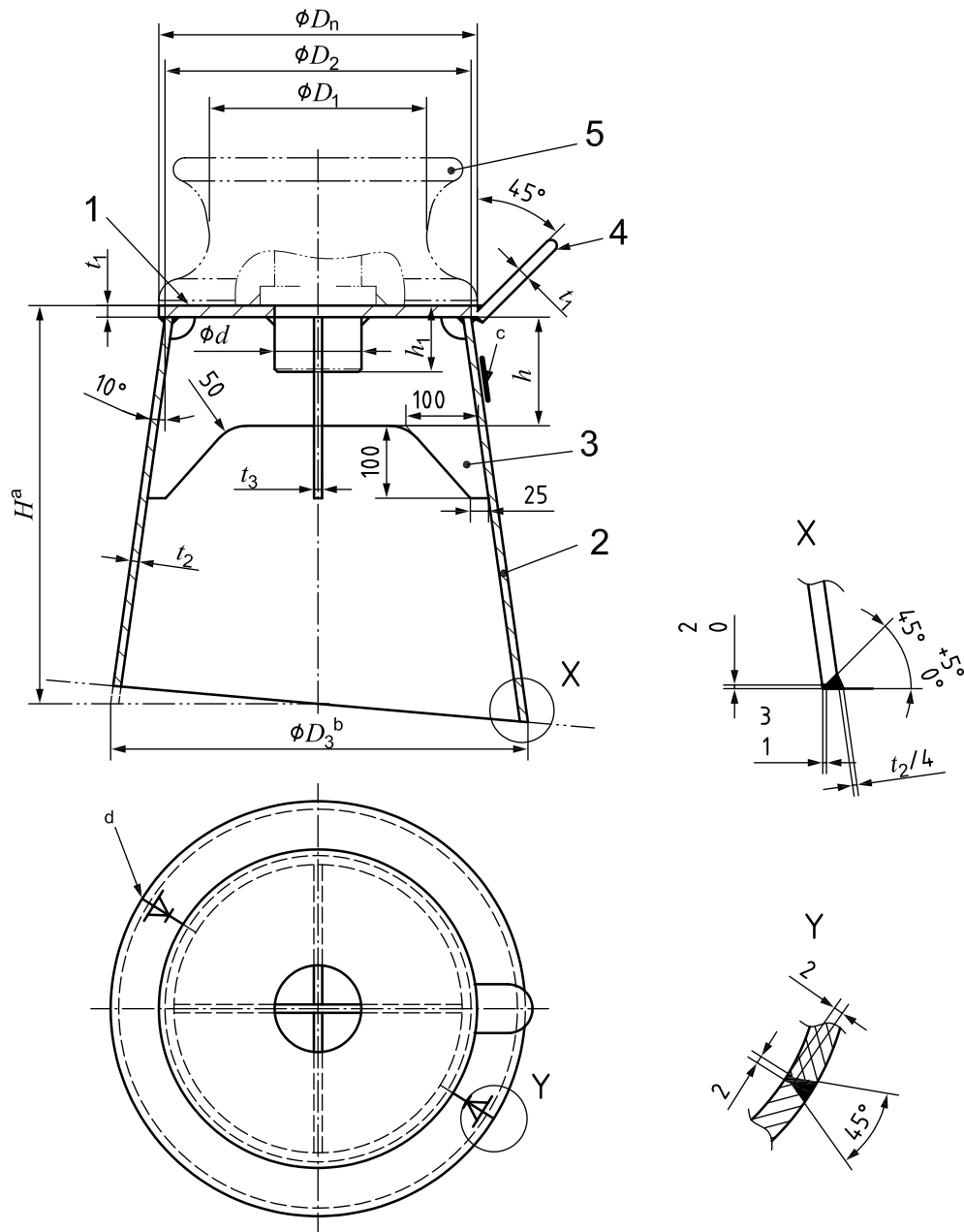

**Key**

- 1 top plate
- 2 body
- 3 reinforcement
- 4 rope guide
- 5 steel roller (ISO 13755 steel rollers)

a Height is to be determined in accordance with actual mooring rope height through the pedestal fairlead.

b Diameter  $\phi D_3$  is to be calculated depending on the height of the pedestal,  $H$  [ $D_3 = D_2 + 2 \times (H - t_1) \times \tan 10^\circ$ ].

c SWL marking.

d Seam.

**Figure 1 — Assembly of pedestal fairleads**

Dimensions in millimetres

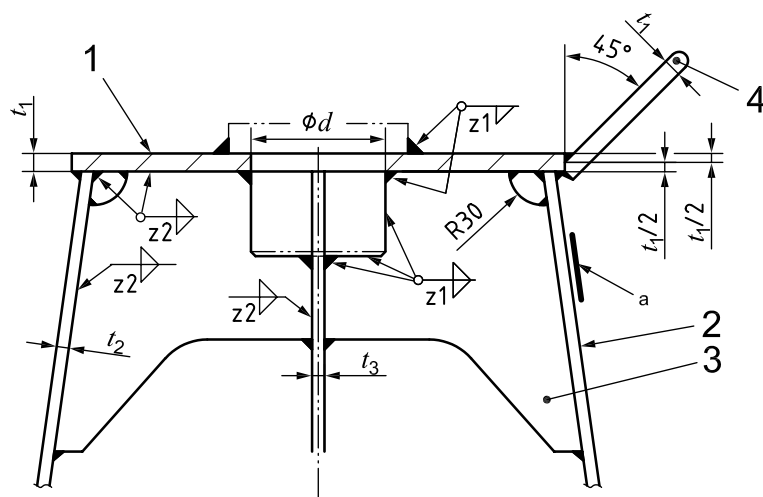

**Key**

- 1 top plate
- 2 body
- 3 reinforcement
- 4 rope guide
- a SWL marking.

**Figure 2 — Detail of pedestal fairleads**

Table 1 — Dimensions and SWL of pedestal fairleads

Dimensions in millimetres

Nominal size $D_n$	$D_1$	$D_2$	$d^e$		$h$	$h_1$	$t_1$	$t_2$	$t_3$	Welding leg length <sup>a</sup>	
			Type A and B	Type C						$z_1$	$z_2$
150	220	230	71,5	81,5	200	100	16	10	16	8	5
200	288	300	93,5	102,5	200	100	20	12	20	10	6
250	357	370	113,5	119,5	200	100	22	12,5	22	11	6
300	417	430	128,5	130,5	225	125	24	13	24	12	6,5
350	472	490	145,5	152,5	225	125	26	17	26	15	8,5
400	540	560	154,5	164,5	250	150	28	18	28	17	9
450	600	620	167,5	179,5	250	150	30	20	30	20	10
500	655	680	178,5	195,5	250	150	32	22	34	23	11
Nominal size $D_n$	SWL <sup>c</sup>				Calculated weight <sup>d</sup> (kg) (for reference only)						
	$\theta^{b=90^\circ}$		$\theta = 0^\circ$		$H = 500$	$H = 1\ 000$	$H = 1\ 500$				
	(kN)	(t)	(kN)	(t)							
150	265	27	186	19	55	115	198				
200	441	45	314	32	86	169	278				
250	579	59	412	42	113	210	335				
300	726	74	510	52	145	256	395				
350	1 040	106	736	75	201	358	552				
400	1 246	127	883	90	255	436	657				
450	1 599	163	1 128	115	314	530	791				
500	1 942	198	1 373	140	383	636	938				
<p><sup>a</sup> Welding with chamfering is available based on the same welding volume/strength.</p> <p><sup>b</sup> <math>\theta</math> is the relative angle of ropes on the pedestal fairlead (refer to Annex A).</p> <p><sup>c</sup> The SWL is the maximum applicable rope tension based <math>90^\circ</math> (<math>\theta = 90^\circ</math>) and <math>180^\circ</math> (<math>\theta = 0^\circ</math>) deflection of rope direction by the pedestal fairlead.</p> <p>The SWLs shown in this table are for reference only. These are based on the loadings as mentioned in Annex A.</p> <p>The "SWL" may be adjusted depending on the actual loading conditions, and the actual marking shall be agreed between the user and the manufacturer.</p> <p><sup>d</sup> The calculated weight is for reference excluding the steel roller on the pedestal fairlead.</p> <p><sup>e</sup> <math>d</math> shall be decided depending on the type of steel roller (Type A and B or Type C), as specified in ISO 13755.</p>											

## Annex A (informative)

### Basis for strength assessment of pedestal fairleads

#### A.1 General

The strength of the pedestal fairleads was evaluated by finite element model analysis and simple beam theory calculation, and determined based on the following design criteria.

#### A.2 Loading

The pedestal fairleads are to be designed to withstand the following load cases.

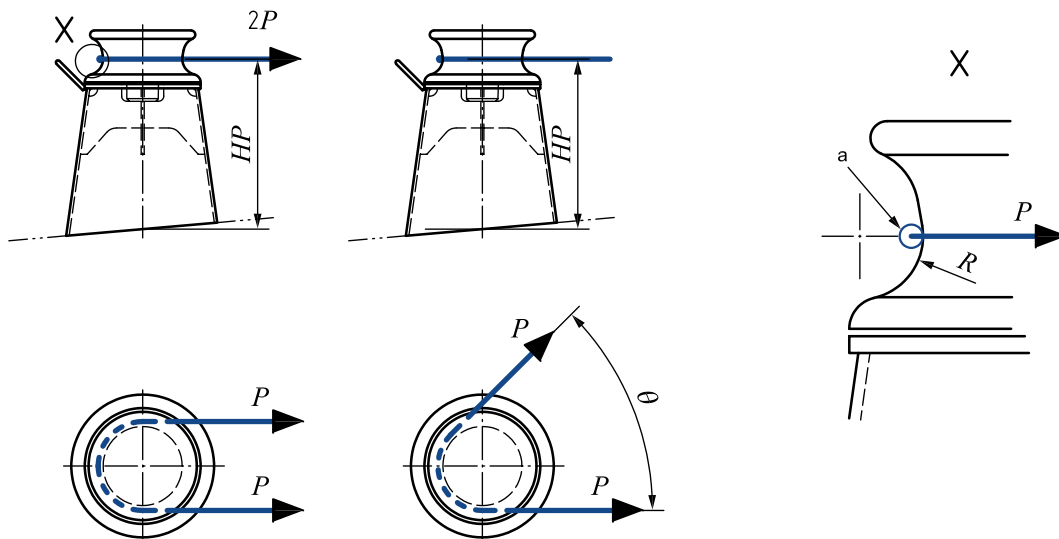

**Key**

$P$  mooring force and towing force at the conical part of the throat of the roller

$a$  Conical part of throat.

NOTE 1 The loads were considered with rope deflected 180° through the pedestal fairlead as shown in this figure.

NOTE 2 The loads can be increased in accordance with the deflecting angle of the rope smaller than 180°.

**Figure A.1 — Loading on pedestal fairleads**

#### A.3 Load and stress criteria

Under the SWL, the following stress criteria were adopted:

- The bending stress is limited to 85 % of the yield stress of the material.
- The shear stress is limited to 60 % of the yield stress of the material.

#### **A.4 Wear-down allowances and corrosion additions**

The wear-down margin and corrosion margin were already included in the safety factor.

## Bibliography

- [1] ISO 2408, *Steel wire ropes for general purposes — Minimum requirements*
- [2] IACS UR A2, *Shipboard fittings and supporting hull structures associated with towing and mooring on conventional vessels*
- [3] OCIMF, *Mooring Equipment Guidelines (MEG3)*



---

---

**ICS 47.020.50**

Price based on 8 pages