

INTERNATIONAL STANDARD

ISO 13774

First edition
1998-03-01

Rubber and plastics hoses for fuels for internal-combustion engines — Method of test for flammability

*Tuyaux en caoutchouc et en plastique pour carburants pour moteurs à
combustion interne — Méthode d'essai d'inflammabilité*

This material is reproduced from ISO documents under International Organization for Standardization (ISO) Copyright License number IHS/ICC/1996. Not for resale. No part of these ISO documents may be reproduced in any form, electronic retrieval system or otherwise, except as allowed in the copyright law of the country of use, or with the prior written consent of ISO (Case postale 56, 1211 Geneva 20, Switzerland, Fax +41 22 734 10 79), IHS or the ISO Licensor's members.



Reference number
ISO 13774:1998(E)

ISO 13774:1998(E)**Foreword**

ISO (the International Organization for Standardization) is a worldwide federation of national standards bodies (ISO member bodies). The work of preparing International Standards is normally carried out through ISO technical committees. Each member body interested in a subject for which a technical committee has been established has the right to be represented on that committee. International organizations, governmental and non-governmental, in liaison with ISO, also take part in the work. ISO collaborates closely with the International Electrotechnical Commission (IEC) on all matters of electrotechnical standardization.

Draft International Standards adopted by the technical committees are circulated to the member bodies for voting. Publication as an International Standard requires approval by at least 75 % of the member bodies casting a vote.

International Standard ISO 13774 was prepared by Technical Committee ISO/TC 45, *Rubber and rubber products*, Subcommittee SC 1, *Hoses (rubber and plastics)*.

© ISO 1998

All rights reserved. Unless otherwise specified, no part of this publication may be reproduced or utilized in any form or by any means, electronic or mechanical, including photocopying and microfilm, without permission in writing from the publisher.

International Organization for Standardization
Case postale 56 • CH-1211 Genève 20 • Switzerland
Internet central@iso.ch
X.400 c=ch; a=400net; p=iso; o=isocs; s=central

Printed in Switzerland

Rubber and plastics hoses for fuels for internal-combustion engines — Method of test for flammability

WARNING — Persons using this International Standard should be familiar with normal laboratory practice. This standard does not purport to address all of the safety problems, if any, associated with its use. It is the responsibility of the user to establish appropriate safety and health practices and to ensure compliance with any national regulatory conditions.

Attention is drawn to the need for ensuring that the test specified in this International Standard is carried out under suitable environmental conditions and that personnel are adequately protected against risk of fire and inhalation of smoke and/or toxic products of combustion.

1 Scope

This International Standard specifies a method for assessing the flammability of hoses with a nominal bore of 16 or smaller, intended for use with petroleum fuels for internal-combustion engines.

NOTE — The method of test for flammability of other types of rubber and plastics hoses is given in ISO 8030:1995, *Rubber and plastics hoses — Method of test for flammability*.

2 Normative reference

The following standard contains provisions which, through reference in this text, constitute provisions of this International Standard. At the time of publication, the edition indicated was valid. All standards are subject to revision, and parties to agreements based on this International Standard are encouraged to investigate the possibility of applying the most recent edition of the standard indicated below. Members of IEC and ISO maintain registers of currently valid International Standards.

ISO 471:1995, *Rubber — Temperatures, humidities and times for conditioning and testing*.

3 Principle

The hose, filled with heptane, is subjected to fire. No leakage may occur earlier than T min after ignition of the fuel in the tray. The time T is specified in the appropriate product standard.

4 Apparatus and materials

4.1 Draught-free room, maintained at a standard temperature (see ISO 471).

4.2 Steel stands, for supporting the test piece in a horizontal position above the fuel tray (see figure 1).

4.3 Glass tube, for supplying the test piece with fuel at a certain pressure (fuel level 900 mm above the test piece).

4.4 Fuel tray, of square shape, 350 mm × 350 mm, with vertical, 40-mm-high sides.

4.5 Fuel, consisting of commercial heptane with a distillation range of 80 °C to 110 °C.

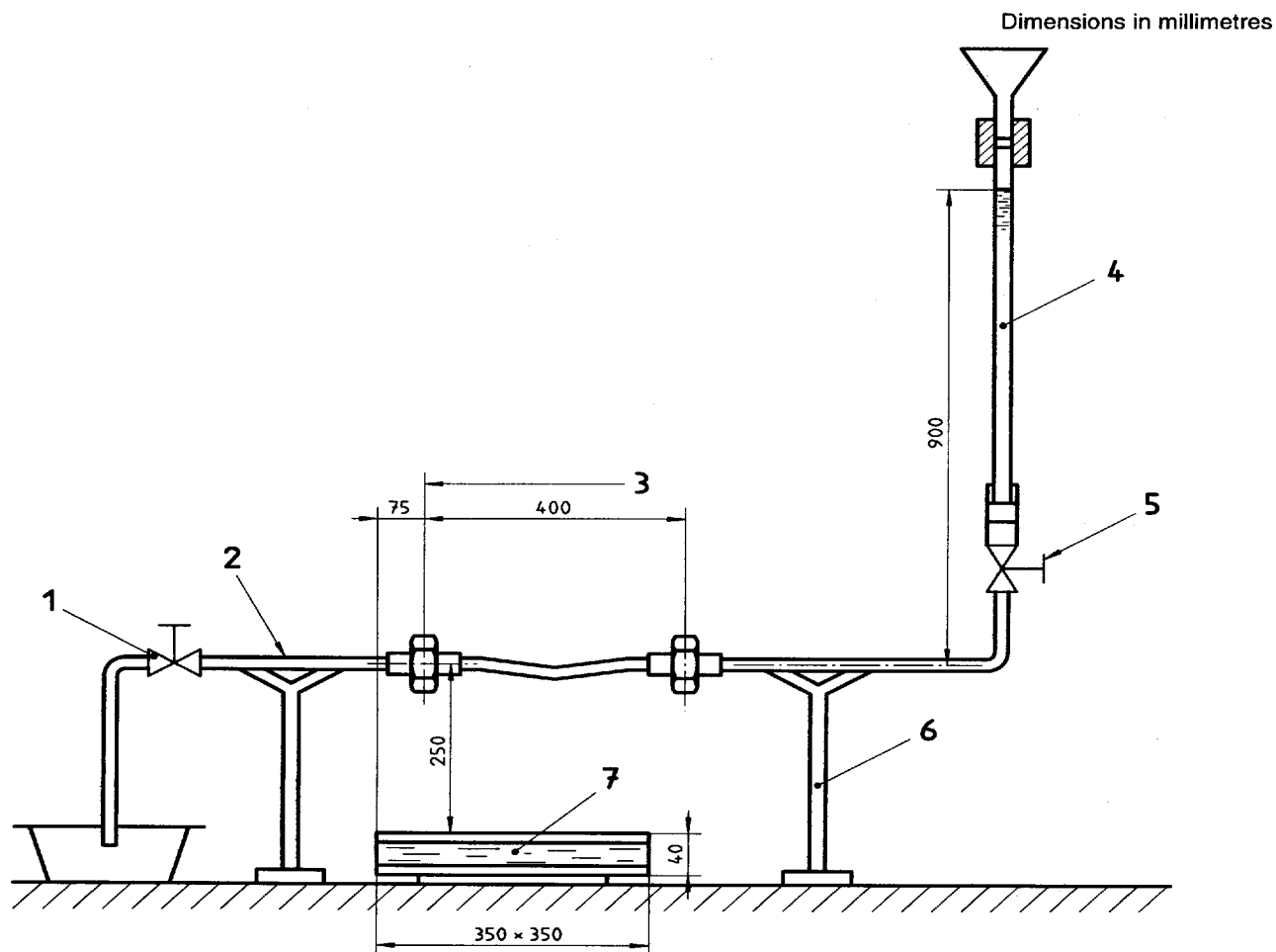

Key

- 1 Discharge valve
- 2 Steel fuel line
- 3 End of test piece
Mount without longitudinal stress
- 4 Glass tube
- 5 Fuel valve
- 6 Steel stand
- 7 Fuel pan with 0,5 dm³ water and 2 dm³ heptane

Figure 1 — Test apparatus

5 Test pieces

Hose assemblies with a length of 400 mm (see figure 1) shall be used.

At least three test pieces shall be tested.

6 Conditioning of test pieces

No test shall be carried out within 24 h of manufacture.

Test pieces shall be conditioned at standard temperature and humidity (see ISO 471) for at least 3 h before testing. This may be part of the 24 h period after manufacture.

7 Procedure

WARNING — Large flames and burning waste fluid could occur during any leakage. Therefore the test shall be performed in a non-combustible environment by personnel equipped with protective equipment and fire-fighting equipment.

7.1 Preparations

Arrange the test equipment to conform to figure 1 without mounting any test piece. Fill the fuel tray as stated below, ignite the fuel and note that a stable flame is obtained. Non-measurable draught effects in the room could influence the flame and, if so, the position of the fuel tray shall be changed, in order to embrace the hose and one of its ends in the flame. Extinguish the flames and allow the whole apparatus to cool to ambient temperature.

7.2 Test

Mount a test piece in place and fill it with fuel by opening the fuel valve. Ensure that no air is left in the hose. Adjust the fuel level to 900 mm above the test piece.

Pour 0,5 dm³ of water and 2 dm³ of heptane into the fuel tray and ignite the heptane. The fuel tray shall be placed so that two of the sides are parallel with the test piece.

Allow the heptane to burn and record the time to leakage.

Leakage will be evident by the increase in the intensity of the fire at the position of leakage.

The test is terminated when leakage occurs or when the heptane in the fuel tray is burnt off.

If the flame is very unstable during the test and does not expose the test piece to a full extent during more than 25 % of the duration of the test, or if the time to leakage in any test deviates by more than 30 s from the mean value determined, test another two test pieces.

After each test, cool the fuel lines and fuel tray to ambient temperature before mounting a new test piece and replacing the water and fuel.

8 Test report

The test report shall include the following particulars:

- a) a reference to this International Standard;
- b) a full description of the hose tested;

- c) the test conditions, e.g. the temperature in the room and observations concerning any draught;
- d) the time to leakage for each test piece and the mean value;
- e) if no leakage occurs, the time the hose was exposed to fire;
- f) the date of the test.

ICS 13.220.40; 75.200; 83.140.40

Descriptors: rubber products, plastics products, hoses, fluid circuits, automotive fuels, rubber hoses, plastics hoses, tests, flammability testing.

Price based on 4 pages
