**Ships and marine technology — Ship's
mooring and towing fittings — Universal
fairleads with upper roller**

*Navires et technologie maritime — Corps-morts et ferrures de
remorquage de navires — Chaumards universels avec rouleau supérieur*





COPYRIGHT PROTECTED DOCUMENT

© ISO 2012

All rights reserved. Unless otherwise specified, no part of this publication may be reproduced or utilized in any form or by any means, electronic or mechanical, including photocopying and microfilm, without permission in writing from either ISO at the address below or ISO's member body in the country of the requester.

ISO copyright office
Case postale 56 • CH-1211 Geneva 20
Tel. + 41 22 749 01 11
Fax + 41 22 749 09 47
E-mail copyright@iso.org
Web www.iso.org

Published in Switzerland

Contents

Page

Foreword	iv
Introduction	v
1 Scope	1
2 Normative references	1
3 Terms and definitions	1
4 Classification	1
4.1 Type	1
4.2 Nominal sizes	1
5 Dimensions	2
6 Materials	2
7 Construction	2
8 Manufacturing and inspection	2
9 Marking	2
Annex A (informative) Basis for strength assessment of universal fairleads	15
Bibliography	18

.....

Foreword

ISO (the International Organization for Standardization) is a worldwide federation of national standards bodies (ISO member bodies). The work of preparing International Standards is normally carried out through ISO technical committees. Each member body interested in a subject for which a technical committee has been established has the right to be represented on that committee. International organizations, governmental and non-governmental, in liaison with ISO, also take part in the work. ISO collaborates closely with the International Electrotechnical Commission (IEC) on all matters of electrotechnical standardization.

International Standards are drafted in accordance with the rules given in the ISO/IEC Directives, Part 2.

The main task of technical committees is to prepare International Standards. Draft International Standards adopted by the technical committees are circulated to the member bodies for voting. Publication as an International Standard requires approval by at least 75 % of the member bodies casting a vote.

Attention is drawn to the possibility that some of the elements of this document may be the subject of patent rights. ISO shall not be held responsible for identifying any or all such patent rights.

ISO 13733 was prepared by Technical Committee ISO/TC 8, *Ships and marine technology*, Subcommittee SC 4, *Outfitting and deck machinery*.

Introduction

The universal fairlead is a type of ship's mooring fitting installed on board to lead the mooring rope from the ship's inboard to outboard.

Ships and marine technology — Ship's mooring and towing fittings — Universal fairleads with upper roller

1 Scope

This International Standard specifies the design, size and technical requirements for universal fairleads with upper roller(s) installed to lead the mooring rope of a ship.

2 Normative references

The following referenced documents are indispensable for the application of this document. For dated references, only the edition cited applies. For undated references, the latest edition of the referenced document (including any amendments) applies.

IMO Circular MSC/Circ.1175, *Guidance on shipboard towing and mooring equipment*

3 Terms and definitions

For the purposes of this document, the following terms and definitions apply.

3.1

safe working load

SWL

maximum load in kN on the rope that should normally be applied in service conditions

4 Classification

4.1 Type

Depending on the construction, universal fairleads are to be classified as the following four types:

- type 4R: with one rope-passing opening;
- type 5RL: with one rope-passing opening with additional guide roller on left side;
- type 5RR: with one rope-passing opening with additional guide roller on right side;
- type 7R: with two rope-passing openings.

4.2 Nominal sizes

The nominal sizes, D_n , of universal fairleads are denoted by reference to the outside diameter of the main roller in millimetres, in terms of the nearest number drawn from a basic series of preferred numbers. For the universal fairleads having the same roller diameter, the alphabetical character is followed by nominal size for the different SWL.

The nominal sizes are:

140, 160, 180, 200, 250, 300A, 300B, 400A, 400B and 400C.

5 Dimensions

Universal fairleads have dimensions and particulars in accordance with Tables 1, 2, 3 and 4, and Figures 1, 2, 3, 4 and 5.

6 Materials

The materials of the following components are to be used for manufacturing the universal fairleads:

- Frame and other plates: weldable steel plates having a yield point of not less than 235 N/mm² except frame with rope guide for nominal size 400A, 400B and 400C shall be made of weldable steel plates having a yield point of not less than 315 N/mm².
- Roller: weldable steel plates having a yield point of not less than 235 N/mm² except rollers for nominal size 400A, 400B and 400C shall be made of weldable steel plates having a yield point of not less than 315 N/mm², or equivalent steel tubes.
- Axle: carbon steel having a yield point of not less than 345 N/mm².
- Bush: brass or bronze or equivalent.

7 Construction

7.1 The rollers of the universal fairleads shall be constructed from steel tubes or formed from plate.

7.2 The foundation of the universal fairleads shall be determined by the manufacturer. The foundation and welding connections to the hull shall be guaranteed reliable transmission of the maximum loading of the universal fairleads to hull construction without any plastic deformation or cracks.

8 Manufacturing and inspection

8.1 All surfaces of the universal fairleads, including welding, shall be free from any visible flaws or imperfections.

8.2 All surfaces in contact with the ropes shall be free from surface roughness or irregularities likely to cause damage to the ropes by abrasion.

8.3 The universal fairleads shall be coated externally with an anti-corrosion protective finish.

8.4 All rotating parts shall be provided with greasing.

9 Marking

9.1 The safe working load (SWL) intended for the use of the universal fairleads shall be noted in the towing and mooring plan available on board for the guidance of the shipmaster as specified in MSC/Circ.1175.

9.2 The actual SWL on board shall be determined by considering the foundation and under deck reinforcement, and it shall be marked on the towing and mooring plan. The actual SWL shall not be over the SWL in this International Standard.

9.3 The universal fairleads are to be clearly marked with their SWL by weld bead or equivalent. The SWL shall be expressed in tonnes (letter 't') and be placed so that it is not obscured during operation of the fitting.

EXAMPLE SWL XXX t

Dimensions in millimetres

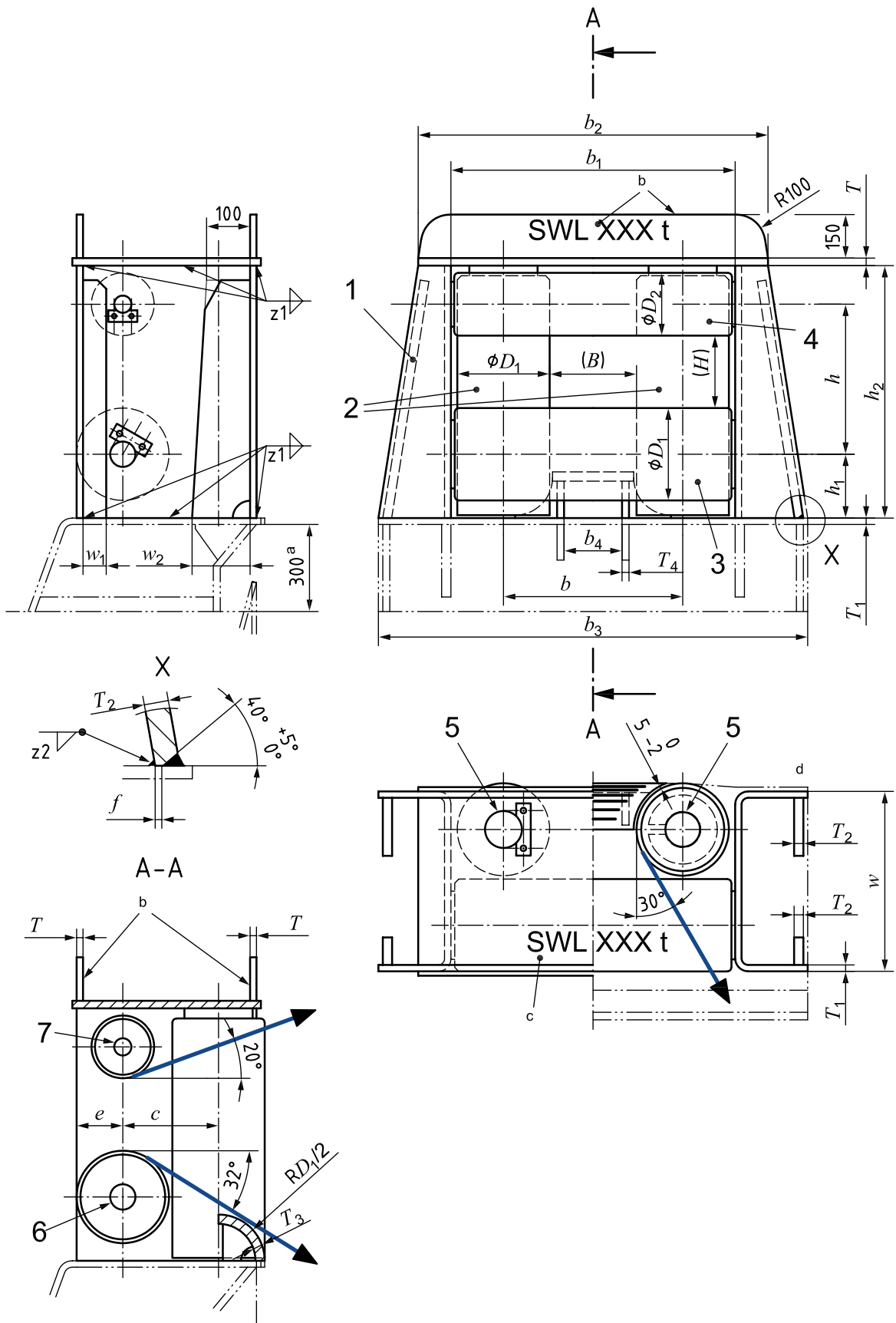

Key

- 1 frame with rope guide
 - 2 vertical rollers with housing and washers
 - 3 lower horizontal roller with washers
 - 4 upper horizontal roller with washers
 - 5 vertical axles with stopper
 - 6 lower horizontal axle with stoppers
 - 7 upper horizontal axle with stoppers
- a Height of seat shall be determined in accordance with the hull construction design.
- b For nominal size 250 and above.
- c For nominal size between 140 and 200 only.
- d Side shell.

Figure 1 — Assembly of type 4R universal fairleads

Dimensions in millimetres

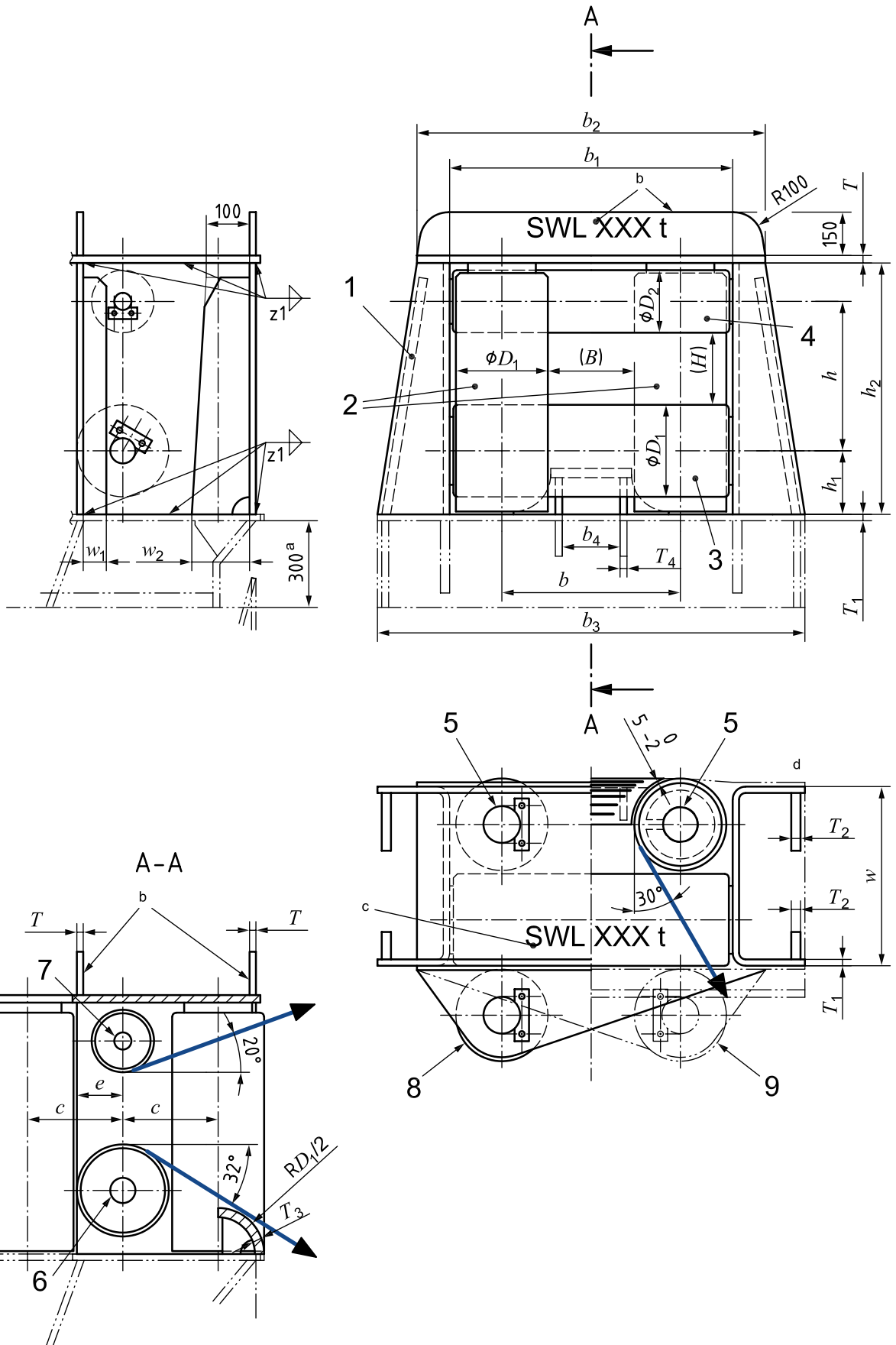

Key

- 1 frame with rope guide
 - 2 vertical rollers with housing and washers
 - 3 lower horizontal roller with washers
 - 4 upper horizontal roller with washers
 - 5 vertical axles with stopper
 - 6 lower horizontal axle with stoppers
 - 7 upper horizontal axle with stoppers
 - 8 type 5RL
 - 9 type 5RR
- a Height of seat shall be determined in accordance with the hull construction design.
 - b For nominal size 250 and above.
 - c For nominal size between 140 and 200 only.
 - d Side shell.

NOTE Details not shown in this figure; refer to Figure 1.

Figure 2 — Assembly of type 5RL and 5RR universal fairleads

Table 1 — Dimensions and SWL of type 4R, 5RL and 5RR universal fairleads

Dimensions in millimetres

Nominal size D_n	$B \times H$	D_1	D_2	h	h_1	h_2	b	b_1	b_2	b_3	b_4	w	c
140	195 × 150	139,8	114,3	277	130	480	335	515	656	820	140	260	150
160	200 × 150	165,2	114,3	290	145	515	365	570	730	920	140	310	175
180	200 × 150	190,7	139,8	315	155	560	391	620	800	1 000	140	360	200
200	200 × 150	216,3	139,8	328	170	590	416	675	896	1 110	140	410	225
250	250 × 200	267,4	165,2	416	195	715	517	825	1 046	1 270	180	520	280
300A	300 × 250	318,5	216,3	517	220	870	618	980	1 206	1 480	200	620	330
300B	300 × 250	318,5	216,3	517	220	870	618	980	1 206	1 480	200	620	330
400A	350 × 250	406,4	216,3	561	265	960	756	1 210	1 450	1 750	200	795	420
400B	350 × 250	406,4	216,3	561	265	960	756	1 210	1 450	1 750	200	795	420
400C	350 × 250	406,4	216,3	561	265	960	756	1 210	1 450	1 750	200	795	420

Table 1 (continued)

Dimensions in millimetres

Nominal size D_n	e	w_1	w_2	T	T_1	T_2	T_3	T_4	f	Welding leg length ^{a,b}		SWL ^c		Calculated weight ^d kg	
										z_1	z_2	(kN)	(t)	4R	5R
140	70	30	100	12	10	10	12	12	3	7	4	137	14	159	194
160	83	40	100	14	10	14	14	14	4	7	5	196	20	218	267
180	95	40	100	16	10	14	16	16	4	7	5	245	25	279	343
200	108	50	100	18	12	16	18	18	6	9	7	314	32	373	455
250	133	65	200	22	16	18	20	20	6	11	7	510	52	730	877
300A	159	80	200	24	20	22	24	22	7	14	8	687	70	1 173	1 411
300B	159	80	200	26	22	24	24	22	8	15	9	736	75	1 267	1 521
400A	203	100	200	26	22	22	32	28	7	15	8	981	100	1 710	2 032
400B	203	100	200	28	24	26	32	28	8	17	9	1 256	128	1 958	2 332
400C	203	100	200	30	26	28	32	28	8	18	9	1 373	140	2 114	2 516

^a Welding with chamfering is available based on the same welding volume/strength.

^b Welding otherwise mentioned in the figures in this International Standard and in this table: minimum leg length is to be 1/2 of thinner plate thickness.

^c The SWL is the maximum applicable rope tension.

The SWLs shown in this table are for reference only. These are based on the loadings as mentioned in Annex A.

The "SWL" may be adjusted depending on the actual loading conditions, and the actual marking shall be agreed between the user and the manufacturer.

^d The calculated weight is for reference only excluding foundation.

Dimensions in millimetres

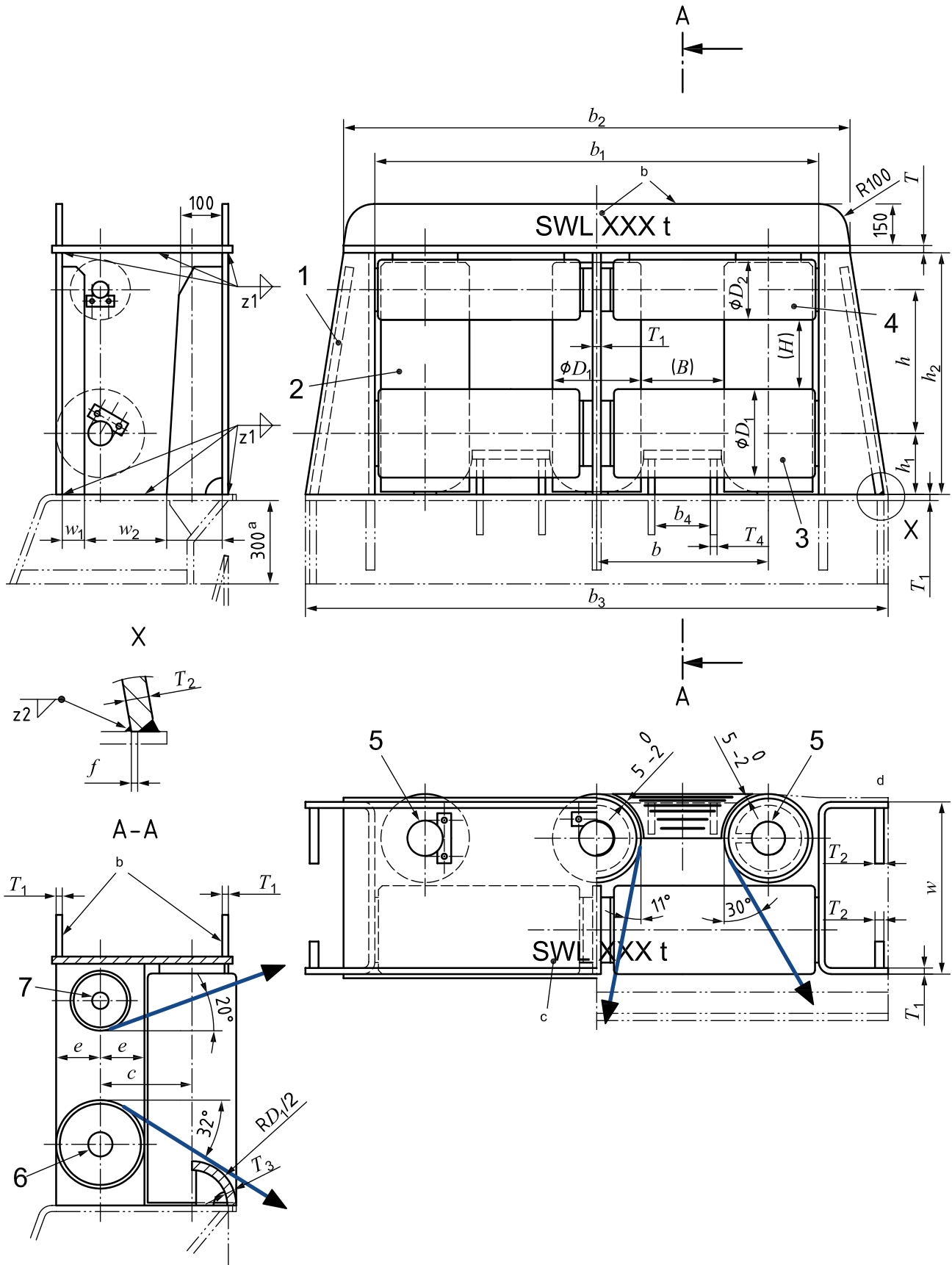

Key

- 1 frame with rope guide
 - 2 vertical rollers with housing and washers
 - 3 lower horizontal roller with housing and washers
 - 4 upper horizontal roller with housing and washers
 - 5 vertical axles with stopper
 - 6 lower horizontal axle with stoppers
 - 7 upper horizontal axle with stoppers
- a Height of seat shall be determined in accordance with the hull construction design.
 - b For nominal size 250 and above.
 - c For nominal size between 140 and 200 only.
 - d Side shell.

Figure 3 — Assembly of type 7R universal fairleads**Table 2 — Dimensions and SWL of type 7R universal fairleads**

Dimensions in millimetres

Nominal size D_n	$B \times H$	D_1	D_2	h	h_1	h_2	b	b_1	b_2	b_3	b_4	w	c
140	195 × 150	139,8	114,3	277	130	480	335	850	1 000	1 160	140	260	150
160	200 × 150	165,2	114,3	290	145	515	365	935	1 100	1 286	140	310	175
180	200 × 150	190,7	139,8	315	155	560	391	1 011	1 200	1 400	140	360	200
200	200 × 150	216,3	139,8	328	170	590	416	1 091	1 320	1 550	140	410	225
250	250 × 200	267,4	165,2	416	195	715	517	1 342	1 580	1 820	180	520	280
300A	300 × 250	318,5	216,3	517	220	870	618	1 598	1 840	2 150	200	620	330
300B	300 × 250	318,5	216,3	517	220	870	618	1 598	1 840	2 150	200	620	330
400A	350 × 250	406,4	216,3	561	265	960	756	1 966	2 250	2 550	200	795	420
400B	350 × 250	406,4	216,3	561	265	960	756	1 966	2 250	2 550	200	795	420
400C	350 × 250	406,4	216,3	561	265	960	756	1 966	2 250	2 550	200	795	420

Table 2 (continued)

Dimensions in millimetres

Nominal size D_n	e	w_1	w_2	T	T_1	T_2	T_3	T_4	f	Welding leg length ^{a,b}		SWL ^c		Calculated weight ^d
										z_1	z_2	(kN)	(t)	(kg)
140	70	30	100	12	12	18	12	12	6	9	7	137	14	256
160	83	40	100	14	14	20	14	14	6	10	7	196	20	357
180	95	40	100	16	16	28	16	16	8	11	9	245	25	481
200	108	50	100	18	18	28	18	18	8	13	9	314	32	629
250	133	65	200	22	26	36	20	20	10	18	10	510	52	1 307
300A	159	80	200	24	28	46	24	22	10	20	10	687	70	2 013
300B	159	80	200	26	30	48	24	22	10	21	10	736	75	2 154
400A	203	100	200	26	30	40	32	28	10	21	10	981	100	2 924
400B	203	100	200	28	32	52	32	28	10	22	10	1 256	128	3 344
400C	203	100	200	30	34	54	32	28	10	24	10	1 373	140	3 591

^a Welding with chamfering is available based on the same welding volume/strength.
^b Welding otherwise mentioned in the figures in this International Standard and in this table: minimum leg length is to be 1/2 of thinner plate thickness.
^c The SWL is the maximum applicable rope tension.
 The SWLs shown in this table are for reference only. These are based on the loadings as mentioned in Annex A.
 The "SWL" may be adjusted depending on the actual loading conditions, and the actual marking shall be as agreed between the user and the manufacturer.
^d The calculated weight is for reference excluding foundation.

Dimensions in millimetres

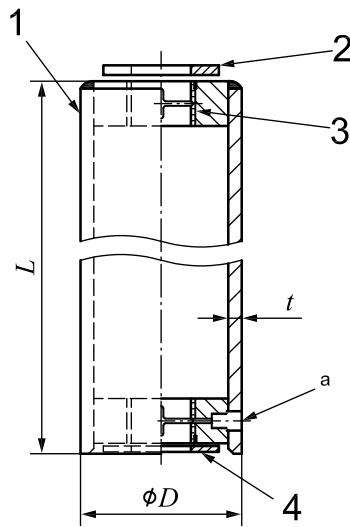

a) Vertical roller

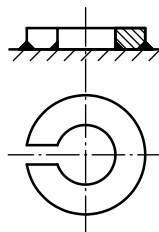

b) Lower support for vertical roller

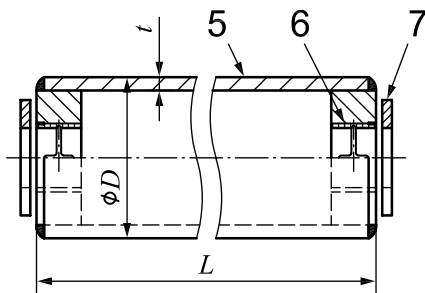

c) Horizontal roller

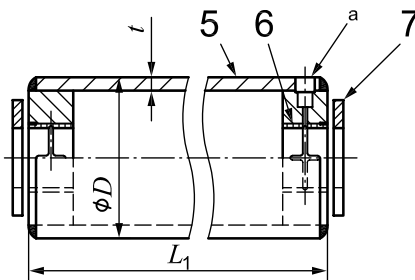

d) Type 7R horizontal roller

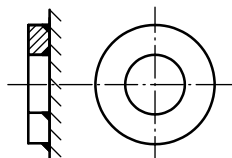

e) Horizontal supports for type 7R horizontal rollers

Key

- 1 vertical roller
- 2 upper washer for vertical roller
- 3 bushes for vertical roller
- 4 lower washer for vertical roller
- 5 horizontal roller
- 6 bushes for horizontal roller
- 7 washer for horizontal roller
- a Grease nipple shall be sunken to avoid rope damage.

Figure 4 — Assembly of rollers

Table 3 — Dimensions of rollers

Dimensions in millimetres

Nominal size D_n	Vertical roller			Lower horizontal roller				Upper horizontal roller			
	D	t	L	D	t	L	L_1	D	t	L	L_1
140	139,8	10	445	139,8	8	499	383	114,3	6	499	383
160	165,2	10	480	165,2	8	554	422	114,3	7	554	422
180	190,7	10	525	190,7	8	600	453	139,8	7	604	457
200	216,3	10	555	216,3	8	655	490	139,8	9	659	494
250	267,4	12	680	267,4	10	799	602	165,2	12	807	610
300A	318,5	14	830	318,5	10	954	725	216,3	11	958	729
300B	318,5	15	830	318,5	11	954	724	216,3	12	958	728
400A	406,4	10	920	406,4	10	1 184	908	216,3	15	1 188	912
400B	406,4	12	920	406,4	11	1 184	907	216,3	21	1 188	911
400C	406,4	13	920	406,4	12	1 184	906	216,3	24	1 188	910

Dimensions in millimetres

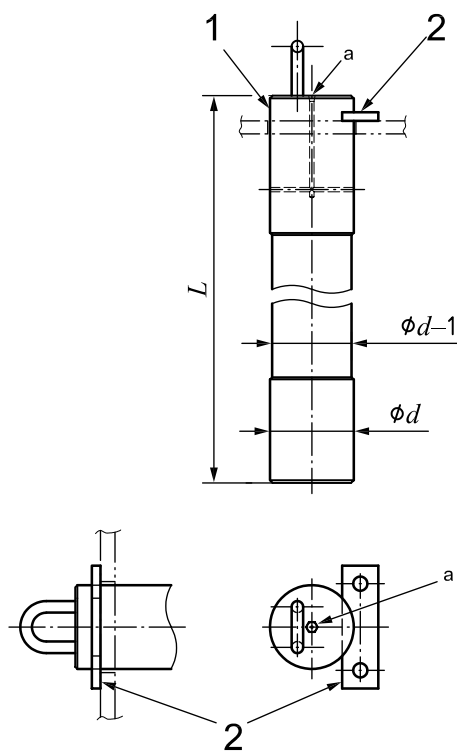

a) Vertical axle

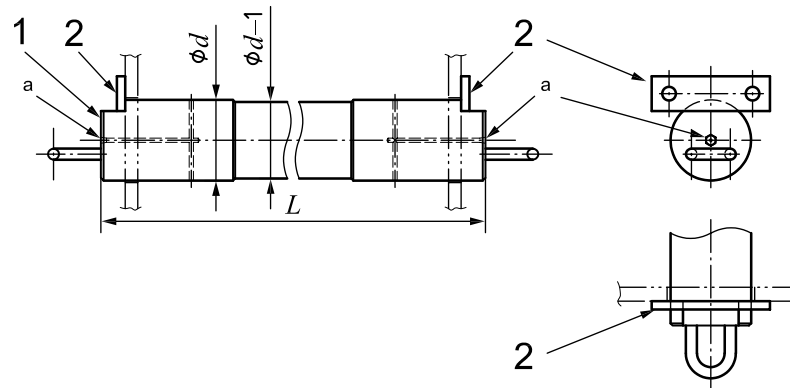

b) Horizontal axle

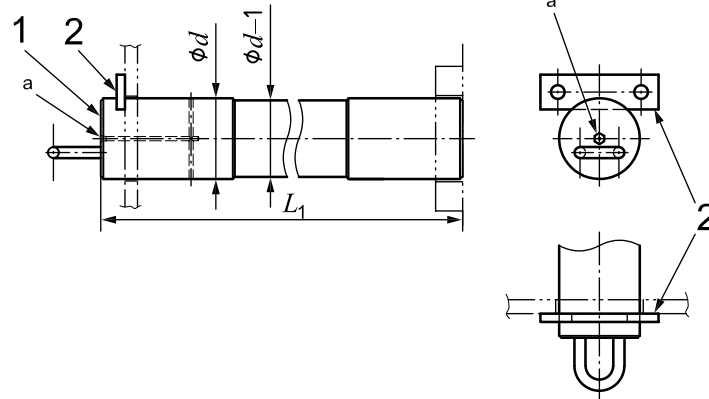

c) Type 7R horizontal axle

Key

- 1 axle
- 2 key set for axle
- a Grease nipple.

Figure 5 — Assembly of axles

Table 4 — Dimensions of axles

Dimensions in millimetres

Nominal size D_n	Vertical axle		Lower horizontal axle			Upper horizontal axle		
	d	L	d	L	L_1	d	L	L_1
140	65	517	43	555	456	30	555	456
160	76	554	49	614	499	34	610	499
180	82	604	55	670	541	37	660	541
200	91	636	61	729	582	40	719	582
250	111	765	78	893	712	51	881	712
300A	128	929	89	1 056	848	60	1 050	848
300B	131	931	92	1 060	849	62	1 054	849
400A	153	1 021	106	1 290	1 033	69	1 284	1 033
400B	166	1 023	115	1 294	1 034	75	1 288	1 034
400C	171	1 025	119	1 298	1 035	78	1 292	1 035

Annex A (informative)

Basis for strength assessment of universal fairleads

A.1 General

The strength of the universal fairleads was evaluated by finite element model analysis for frames and rope guide plates, and simple beam theory calculation for rollers and axles, and determined based on the following design criteria.

A.2 Loading

The universal fairleads are to be designed to withstand the horizontal and vertical load cases.

Horizontal and vertical loadings were considered individually, but both loadings were not considered simultaneously.

A.2.1 Case 1 — Horizontal loading

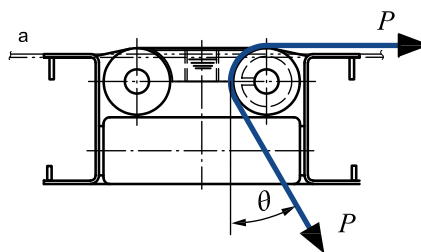
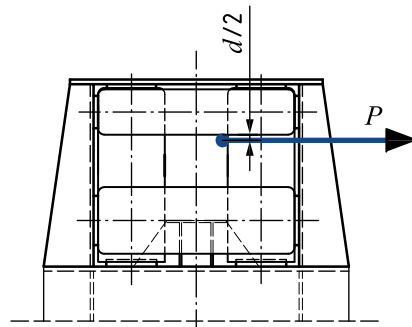

a) Type 4R

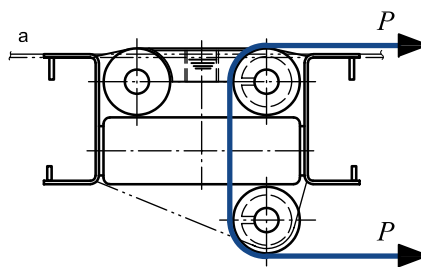

b) Type 5R

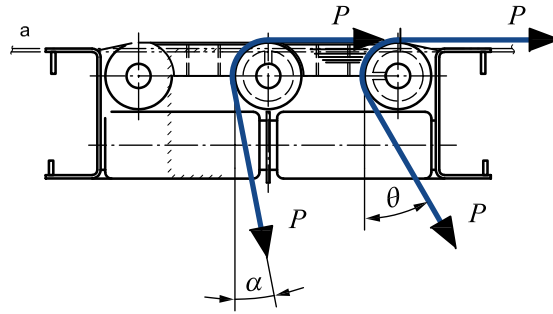

c) Type 7R

Key

- P mooring force
- d diameter of mooring rope (wire rope base) as in Table A.1
- a Ship side.

NOTE The loads were considered with rope deflected $\theta = 30^\circ$ and $\alpha = 11^\circ$ through the universal fairlead as shown in this figure.

Figure A.1 — Horizontal loading

A.2.2 Case 2 — Vertical loading

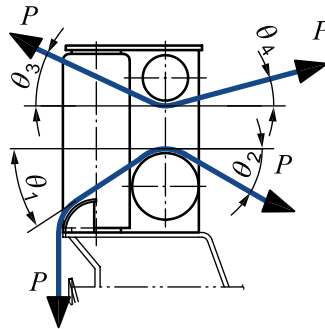

Key

- P mooring force

NOTE The loads were considered with rope deflected to down side $\theta_1 = 90^\circ$ and $\theta_2 = 30^\circ$, and to up side $\theta_3 = 20^\circ$ and $\theta_4 = 5^\circ$ through the universal fairlead respectively as shown in this figure.

Figure A.2 — Vertical loading

A.2.3 Single load was considered for type 4R, 5RL and 5RR, and simultaneous loadings were considered for type 7R universal fairleads.

A.2.4 For the consideration of load point from the mooring ropes, the wire ropes shown in Table A.1 were adopted.

Table A.1 — Diameter of applied wire ropes for load consideration

Dimensions in millimetres

Nominal size D_n	Wire rope diameter d
140	14,0
160	16,5
180	19,0
200	21,6
250	27,0
300A	32,0
300B	34,0
400A	40,0
400B	44,0
400C	44,0

A.3 Load and stress criteria

Under the SWL, the following stress criteria were adopted:

For finite element model analysis of frames and rope guide plates, the combined stress is limited to 85 % of the yield stress of the material.

For simple beam theory calculation of rollers and axles:

The bending stress is limited to 85 % of the yield stress of the material.

The shear stress is limited to 60 % of the yield stress of the material.

A.4 Wear-down allowances and corrosion additions

The wear-down margin and corrosion margin were already included in the safety factor.

Bibliography

- [1] IACS UR A2, *Shipboard fittings and supporting hull structures associated with towing and mooring on conventional vessels*
- [2] OCIMF, *Mooring Equipment Guidelines (MEG3)*
- [3] ISO 2408, *Steel wire ropes for general purposes — Minimum requirements*

© 2015 International Organization for Standardization

ICS 47.020.50

Price based on 18 pages