**Ships and marine technology —
Manoeuvring of ships —**

**Part 5:
Submarine specials**

*Navires et technologie maritime — Manoeuvres des navires —
Partie 5: Spécificités des sous-marins*





COPYRIGHT PROTECTED DOCUMENT

© ISO 2013

All rights reserved. Unless otherwise specified, no part of this publication may be reproduced or utilized otherwise in any form or by any means, electronic or mechanical, including photocopying, or posting on the internet or an intranet, without prior written permission. Permission can be requested from either ISO at the address below or ISO's member body in the country of the requester.

ISO copyright office
Case postale 56 • CH-1211 Geneva 20
Tel. + 41 22 749 01 11
Fax + 41 22 749 09 47
E-mail copyright@iso.org
Web www.iso.org

Published in Switzerland

Contents

	Page
Foreword	iv
1 Scope	1
2 Normative references	1
3 Terms and definitions	1
4 Test-related physical quantities	2
5 General test conditions	4
6 Test 5.1 — Meander test	4
6.1 Description	4
6.2 Analysis and presentation of results of a meander test	7
6.3 Evaluation for supercritical or high damping	8
6.4 Evaluation of the time to half-value	9
6.5 Designation of a meander test	10
7 Test 5.2 — Vertical overshoot test	10
7.1 Description	10
7.2 Analysis and presentation of results of a vertical overshoot test	11
7.3 Designation of a vertical overshoot test	12
8 Test 5.3 — Neutral level flight test	13
8.1 Description	13
8.2 Analysis and presentation of results of a neutral level flight test	14
8.3 Designation of a neutral level flight test	18
9 Test 5.4 — Critical speed test	19
9.1 General	19
9.2 Description	19
9.3 Analysis and presentation of results of a critical speed test	19
9.4 Designation of a critical speed test	21
Bibliography	22

.....

Foreword

ISO (the International Organization for Standardization) is a worldwide federation of national standards bodies (ISO member bodies). The work of preparing International Standards is normally carried out through ISO technical committees. Each member body interested in a subject for which a technical committee has been established has the right to be represented on that committee. International organizations, governmental and non-governmental, in liaison with ISO, also take part in the work. ISO collaborates closely with the International Electrotechnical Commission (IEC) on all matters of electrotechnical standardization.

The procedures used to develop this document and those intended for its further maintenance are described in the ISO/IEC Directives, Part 1. In particular the different approval criteria needed for the different types of ISO documents should be noted. This document was drafted in accordance with the editorial rules of the ISO/IEC Directives, Part 2. www.iso.org/directives

Attention is drawn to the possibility that some of the elements of this document may be the subject of patent rights. ISO shall not be held responsible for identifying any or all such patent rights. Details of any patent rights identified during the development of the document will be in the Introduction and/or on the ISO list of patent declarations received. www.iso.org/patents

Any trade name used in this document is information given for the convenience of users and does not constitute an endorsement.

The committee responsible for this document is ISO/TC 8, *Ships and marine technology*, Subcommittee SC 6, *Navigation and ship operations*.

ISO 13643 consists of the following parts, under the general title *Ships and marine technology — Manoeuvring of ships*:

- *Part 1: General concepts, quantities and test conditions*
- *Part 2: Turning and yaw checking*
- *Part 3: Yaw stability and steering*
- *Part 4: Stopping, acceleration, traversing*
- *Part 5: Submarine specials*
- *Part 6: Model test specials*

.....

Ships and marine technology — Manoeuvring of ships —

Part 5: Submarine specials

1 Scope

This part of ISO 13643 defines symbols and terms and provides guidelines for the conduct of tests to give evidence about the manoeuvring ability in the vertical plane of submarines and models. It is intended to be read in conjunction with ISO 13643-1.

2 Normative references

The following documents, in whole or in part, are normatively referenced in this document and are indispensable for its application. For dated references, only the edition cited applies. For undated references, the latest edition of the referenced document (including any amendments) applies.

ISO 13643-1, *Ships and marine technology — Manoeuvring of ships — Part 1: General concepts, quantities and test conditions*

3 Terms and definitions

For the purposes of this document, the following terms and definitions apply.

3.1

meander test

manoeuvring test to establish a submarine's manoeuvring characteristics and to verify the submarine's dynamic stability in the vertical plane

3.2

vertical overshoot test

manoeuvring test to determine the effectiveness of the stern planes when initiating and terminating changes of depth

3.3

neutral level flight test

manoeuvring test to determine the trim angle and the hydroplane angles at which the submarine maintains a constant dived depth at any given speed during submerged operation

Note 1 to entry: Neutral level flight is obtained

- for submarines with retracted bow planes by using a definite trim angle and a definite angle of stern planes, and
- for submarines with non-retractable bow planes, by using definite angles of the bow and stern planes for arbitrary trim angles (preferably $\theta_S = 0^\circ$).

3.4

critical speed test

manoeuvring test to determine the speed at which the effect of the hydroplanes is reversed during submerged operation

4 Test-related physical quantities

Test-related physical quantities are according to [Table 1](#); general quantities and concepts are according to ISO 13643-1.

Table 1 — Test-related physical quantities

Symbol	CC-code	SI unit	Concept	
			Term	Definition or explanation
a_1	–	rad m ² s ⁻² a	Coefficient	For regression approximation
a_2	–	m ² s ⁻²	Coefficient	For regression approximation
b_1	–	rad m ² s ⁻² a	Coefficient	For regression approximation
b_2	–	m ² s ⁻²	Coefficient	For regression approximation
C_c	CCR	1	Damping ratio	Ratio between damping constant $\ln 2/t_{1/2}$ and eigenfrequency $2\pi/T_0$ of the undamped oscillation
c_1	–	rad m ² s ⁻² a	Coefficient	For regression approximation
d_1	–	rad m ² s ⁻² a	Coefficient	For regression approximation
F_V	FVC	N	Vertical force	—
MA	MAX	–	Main axis	(See ISO 13643-1)
M_T	MYT	Nm	Trim moment	—
T	TIP	s	Period of oscillation	Period of the damped oscillation, average of times $[t_{A(i+1)} - t_{Ai}]$
T_0	TIP0	s	Period of oscillation	Period of the undamped oscillation
t_A	TIA	s	Response time	For meander test: Times to achieve the trim amplitudes, θ_{Ai} , $i = 1, 2, 3, \dots$
				For vertical overshoot test: Time to change trim angle by $\Delta\theta_E$
t_C	TIC	s	Overshoot time	Time from putting the stern planes into the opposite direction until reaching maximum trim angle
t_t	TIT	s	Levelling-off time	Time from putting the stern planes into the opposite direction until reaching maximum depth change
$t_{1/2}$	TI05	s	Time to half-value	Time elapsed before the envelope of time-dependent trim variation has decreased by half
V_{CR}	VCR	m s ⁻¹ b	Critical speed	Speed at which the effect of the hydroplanes is reversed
V_F	VF	m s ⁻¹ b	Final speed	Speed at the end of test (run)
V_0	V0	m s ⁻¹ b	Initial speed	(See ISO 13643-1)
V_{0i}	VOI	m s ⁻¹ b	Initial speed	For neutral level flight and vertical overshoot test: For individual runs of the test
V_{0m}	VOM	m s ⁻¹ b	Mean test speed	—
z_0	Z0	m	Dived depth	Vertical coordinate in the earth-fixed axis system of the origin of the submarine (see ISO 13643-1, Table 2) at any given time
z_{00}	Z00	m	Initial dived depth	At the commencement of the test (run)

^a For angles, the unit ° (degree) may be used.

^b The unit kn, common in navigation, may be used.

Table 1 (continued)

Symbol	CC-code	SI unit	Concept	
			Term	Definition or explanation
\dot{z}_{0F}	DZDTF	m s ⁻¹ b	Rate of depth change	When constant trim angle, θ_F , has been reached
Δz_{0E}	DZ0E	m	Response depth change	Change of depth relative to z_{00} when trim angle is changed by $\Delta\theta_E$
Δz_{0F}	DZ0F	m	Final change of dived depth	Under steady final conditions, only defined for a dynamically stable boat
Δz_{0M}	DZ0M	m	Levelling-off depth change	Maximum change of depth, relative to $z_{00} + \Delta z_{0E}$
$\Delta\delta_{Si}$	DANSI	rad ^a	Test stern plane angle	Relative to δ_{S0} ; if necessary, an equivalent stern plane angle shall be given, e.g. for submarines with X-planes: $\frac{1}{4} (\Delta\delta_{Ai1} + \Delta\delta_{Ai2} + \Delta\delta_{Ai3} + \Delta\delta_{Ai4})$.
$\Delta\theta_E$	DTETPE	rad ^a	Execute change of trim angle	For meander test: $\theta_E - \theta_{S0}$ Specified change of trim angle relative to θ_{S0} at which the stern planes are returned to their initial settings δ_{S0}
				For vertical overshoot test: $\theta_E - \theta_{S0}$ Specified change of trim angle relative to θ_{S0} at which the stern planes are applied in the opposite direction (δ_{Si})
δ_B	ANB	rad ^a	Bow plane angle	(See ISO 13643-1)
δ_{B0}	ANB0	rad ^a	Initial bow plane angle	For meander, vertical overshoot, and critical speed tests: Bow plane angle at the commencement of the test (valid for neutral level flight)
			Bow plane angle for neutral level flight	Result of neutral level flight test
δ_S	ANS	rad ^a	Stern plane angle	(See ISO 13643-1)
δ_{SX}	ANSX	rad ^a	Angle of stabilising fin or of the fixed post of a stern plane	Relative to the horizontal plane in MA, positive when leading edge tilts upwards
δ_{SX0}	ANSX0	rad ^a	Angle of stabilising fin or of the fixed post of a stern plane, for neutral level flight	—
δ_{Si}	ANSI	rad ^a	Test stern plane angle	Relative to δ_{S0} ; if necessary, an equivalent stern plane angle shall be given, e.g. for submarines with X-planes: $\frac{1}{4} (\delta_{Ai1} + \delta_{Ai2} + \delta_{Ai3} + \delta_{Ai4})$.
δ_{S0}	ANS0	rad ^a	Initial stern plane angle	For meander, vertical overshoot and critical speed test: Stern plane angle at the commencement of the test (valid for neutral level flight)
			Stern plane angle for neutral level flight	Result of neutral level flight test: If necessary, an equivalent stern plane angle shall be given, e.g. for submarines with X-planes: $\frac{1}{4} (\delta_{A01} + \delta_{A02} + \delta_{A03} + \delta_{A04})$.
<p>^a For angles, the unit ° (degree) may be used.</p> <p>^b The unit kn, common in navigation, may be used.</p>				

Table 1 (continued)

Symbol	CC-code	SI unit	Concept	
			Term	Definition or explanation
θ_A	TRIMSA	rad ^a	Trim amplitude	Absolute value of the respective extreme θ_{Ai} , $i = 1, 2, 3, \dots$ of the change of trim with reference to θ_0
θ_E	TRIMSE	rad ^a	Execute trim angle	$\theta_{S0} + \Delta\theta_E$
θ_F	TRIMSF	rad ^a	Trim angle at the end of run	Constant trim angle for the respective hydroplane settings
θ_S	TRIMS	rad ^a	Trim angle	(See ISO 13643-1)
θ_{SS}	TRIMSS	rad ^a	Overshoot angle	In the vertical plane after applying the stern planes in the opposite direction
θ_{S0}	TRIMS0	rad ^a	Initial trim angle	For meander, vertical overshoot, and critical speed tests: Trim angle at the commencement of the test (valid for neutral level flight)
			Trim angle for neutral level flight	Result of neutral level flight test: Trim angle at which the submarine maintains a constant dived depth

^a For angles, the unit ° (degree) may be used .
^b The unit kn, common in navigation, may be used.

5 General test conditions

In addition to the general test conditions outlined in ISO 13643-1, the following specific test conditions shall be complied with.

- During the test, including the approach phase, each successive position of the ship shall be recorded at suitable time intervals (usually every second).
- The submarine shall be trimmed according to the results of the neutral level flight test (see [Clause 8](#)).
- Dived depth and water depth shall be sufficient (a clearance of at least one boat’s length to the surface and to the bottom shall be maintained). For model tests, surface and bottom effects shall be excluded by the use of suitable measures.
- The bow plane angle shall remain unaltered.
- There shall be no relocation of mass (e.g. due to movements of the crew) during the conduct of any test. Unavoidable shifts of mass are to be compensated and recorded.

6 Test 5.1 — Meander test

6.1 Description

A series of tests for different initial speeds must be conducted since damping and time constants of the motion of the submarine are speed dependent, and a boat that proves to be stable at low speeds may become unstable at higher speeds.

For safety reasons, the series of tests shall be commenced with a low initial speed, V_0 .

The submarine shall approach on a steady speed, V_0 , before commencing the test. During the test, the propulsion plant settings must remain unaltered and the heading kept as constant as possible. Heading and rudder movements shall be recorded throughout the test (ideally, at intervals of 1 s). If the submarine is equipped with planes acting simultaneously in the horizontal and the vertical directions

(e.g. X-planes), these planes should be controlled in such a way that a steady heading is maintained as a matter of priority.

After the submarine has been moving ahead for at least two minutes without significant movements of rudder and planes, the stern planes are set to the specified test stern plane angle, $\Delta\delta_{Si}$, as fast as possible and must be held there until the trim angle has deviated from the initial trim angle, θ_{S0} , by the specified execute change of trim angle, $\Delta\theta_E$. At this point, the stern planes are reversed to the initial position and held until the test is completed.

The stern plane impetus moves the submarine from its equilibrium condition. Test stern plane angle, $\Delta\delta_{Si}$, and execute change of trim angle, $\Delta\theta_E$, shall be selected in such a way that the stern plane impetus acts as quickly and powerfully as possible, and the submarine has at least three measurable trim amplitudes, θ_A , in the case of a subsequent oscillation. Only data after completion of the simulation are to be evaluated.

Because of the stern plane impetus, the submarine turns about its transverse axis and, in doing so, changes its trim and dived depth in the direction in which the planes were acting. Submarines with high damping approach a different dived depth without oscillation about the transverse axis. If the damping is less, the submarine starts to oscillate about the transverse axis. As long as the oscillation is damped, the submarine is stable and approaches a different constant dived depth. On the other hand, if the trim amplitude, θ_A , increases, the submarine is dynamically unstable. The mean dived depth may alter also.

If the submarine demonstrates pronounced instability, the test is to be stopped immediately for safety reasons.

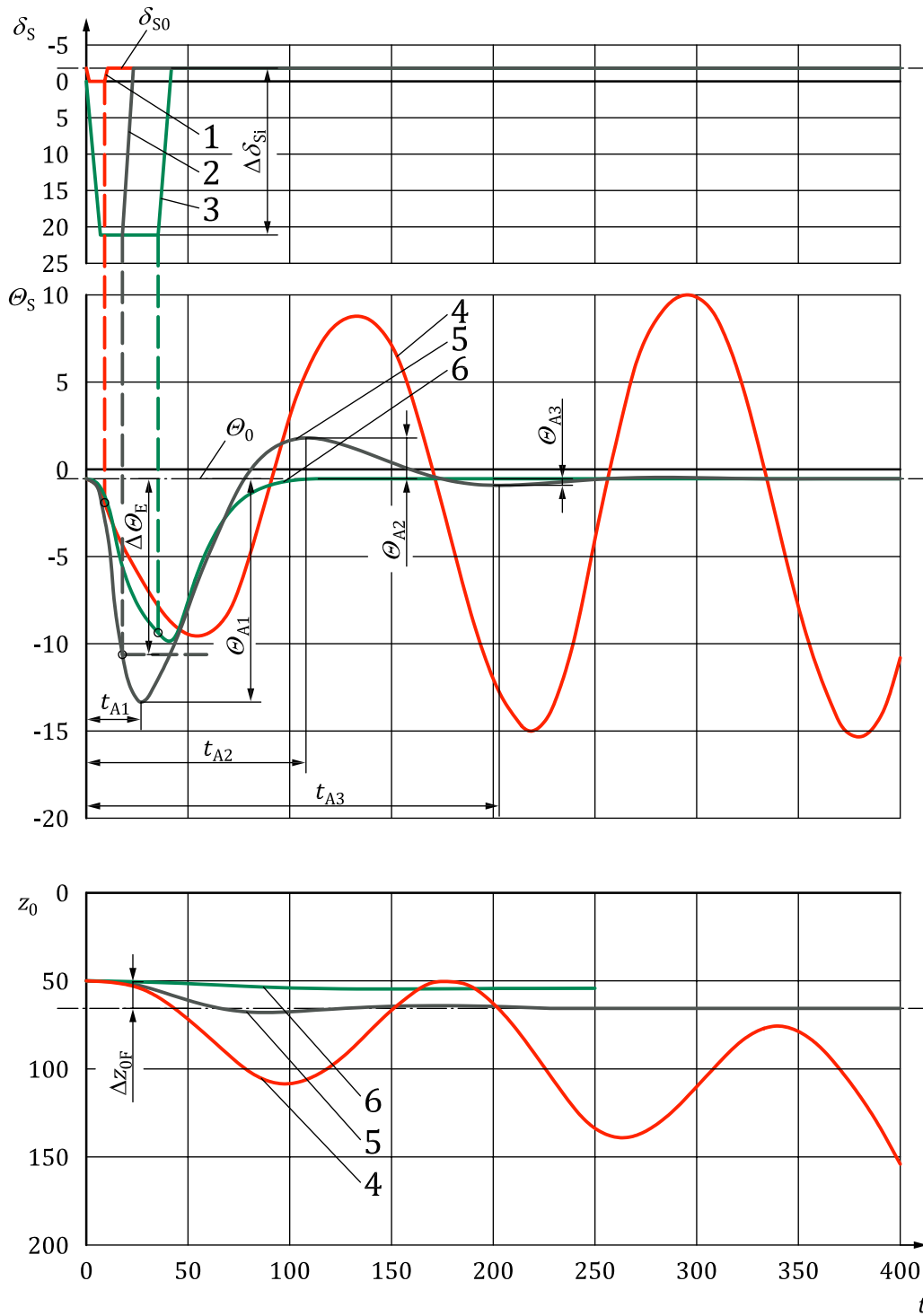

Key

- | | | |
|---|----------------------|------------------------|
| 1 $V_0 = 14,0$ kn, $\Delta\delta_{Si} = 2^\circ$, $\Delta\theta_E = 2^\circ$ (boat dynamically unstable) | 6 | supercritically damped |
| 2 $V_0 = 6,0$ kn, $\Delta\delta_{Si} = 23^\circ$, $\Delta\theta_E = 10^\circ$ (boat dynamically unstable) | δ_s, θ_s | in $^\circ$ |
| 3 $V_0 = 3,9$ kn, $\Delta\delta_{Si} = 23^\circ$, $\Delta\theta_E = 9^\circ$ (boat supercritically damped) | t | in s |
| 4 dynamically unstable | z_0 | in m |
| 5 dynamically unstable | | |

Figure 1 — Time history

6.2 Analysis and presentation of results of a meander test

6.2.1 Evaluation for subcritical damping

The following data are obtained from the test:

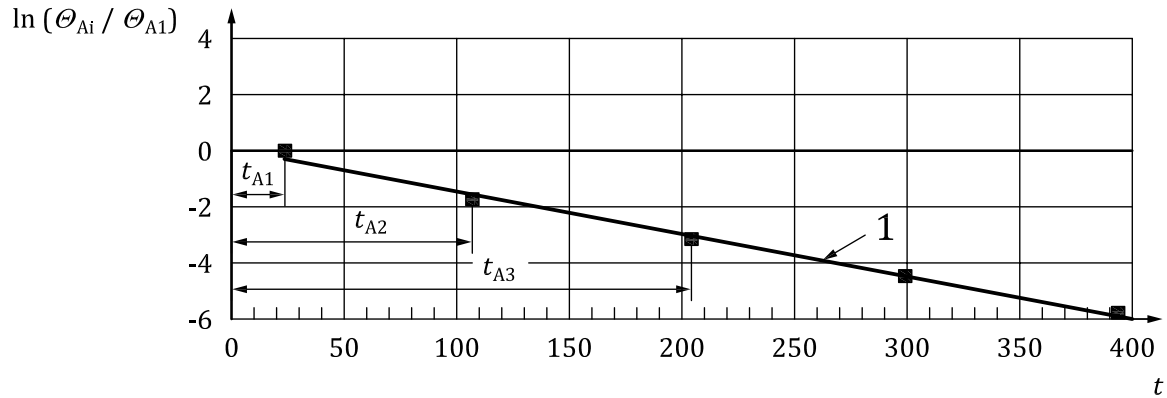

- mean test speed V_{0m}
- trim amplitudes $\theta_{Ai}, i = 1, 2, 3, \dots$
- response times to reach the trim amplitudes, θ_{Ai} $t_{Ai}, i = 1, 2, 3, \dots$
- period of oscillation T
- time to half-value $t_{1/2}$
- final change of dived depth Δz_{0F}

Key

- test with $V_0 = 6$ kn
- linear least square fit for $V_0 = 6$ kn
- 1 slope = $-(\ln 2) / t_{1/2}$
- t in s

Figure 2 — Evaluation

6.2.2 Damping ratio

The damping ratios shall be plotted against the mean test speed, V_{0m} , as shown in [Figure 3](#).

$$C_c = \frac{1}{\sqrt{\left(\frac{2\pi t_{1/2}}{T \ln 2}\right)^2 + 1}}$$

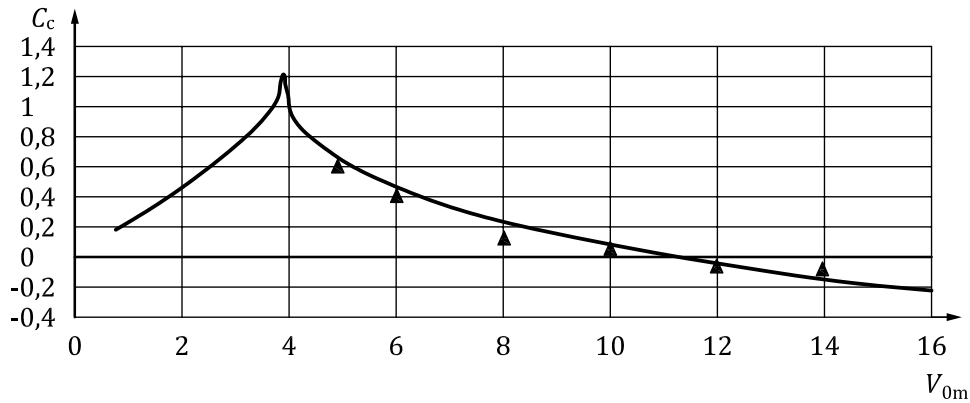

Key
 ▲ test results
 — calculated from hydrodynamic coefficients
 V_{0m} in kn

Figure 3 — Damping ratio

6.3 Evaluation for supercritical or high damping

The following data are obtained from the test:

- mean test speed V_{0m}
- time to half-value $t_{1/2}$
- final change of dived depth Δz_{0F}

At supercritical or high damping, there are no measurable trim oscillations after completion of the stern plane impetus. If the submarine is dynamically stable, the trim angle reaches a maximum θ_{A1} after the stern plane impetus and converges later asymptotically to the initial trim angle, θ_{S0} . The trim angle according to [Figure 4](#) divided by θ_{A1} — and thereby non-dimensional — is plotted logarithmically against time. This is used to find the time to half-value, $t_{1/2}$.

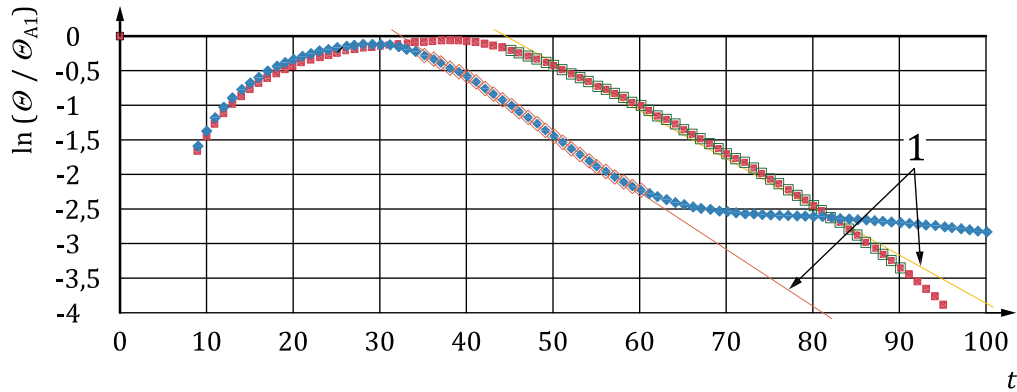

Key

- ◆ $V_0 = 3 \text{ kn}; \Delta\delta_{Si} = 23^\circ; \Delta\theta_E = 5^\circ$
- ◇ points for linear curve fit
- $V_0 = 3,9 \text{ kn}; \Delta\delta_{Si} = 23^\circ; \Delta\theta_E = 9^\circ$
- points for linear curve fit
- 1 linear curve fit slope = $-(\ln 2)/t_{1/2}$
- t in s

Figure 4 — Decay of trim angle

6.4 Evaluation of the time to half-value

The times to half-value $t_{1/2}$ shall be plotted against the mean test speed, V_{0m} , as shown in [Figure 5](#).

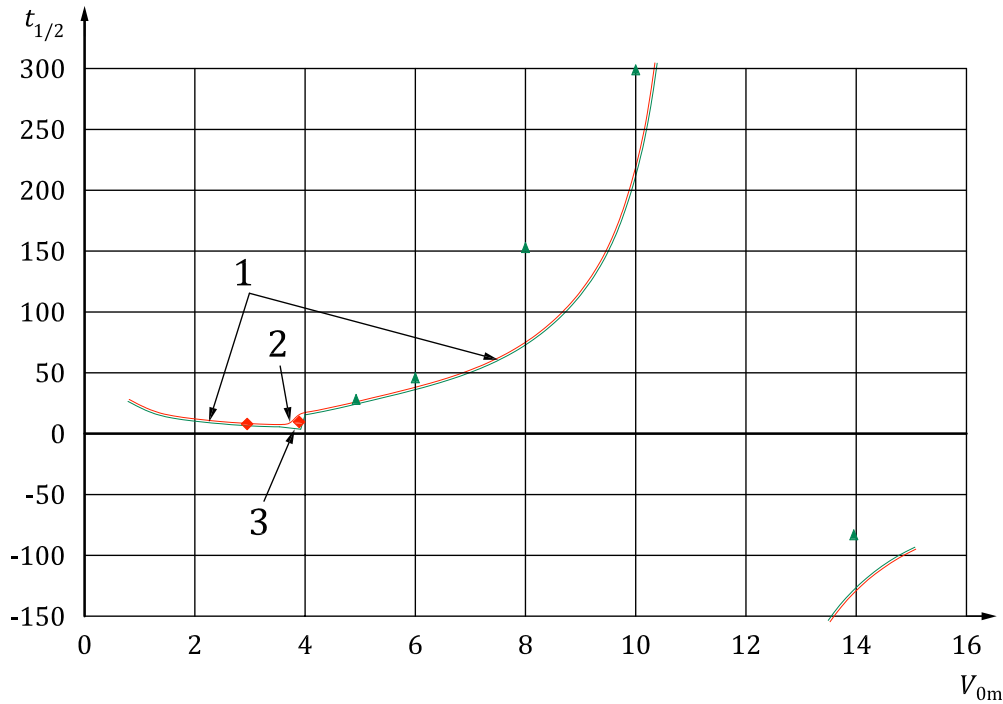

- Key**
- values for the first eigenform, calculated from model test data
 - values for the third eigenform, calculated from model test data
 - ▲ test results: evaluation according to [Figure 2](#)
 - ◆ test results: evaluation according to [Figure 4](#)
 - 1 identical values for first and third eigenform
 - 2 third eigenform
 - 3 first eigenform
 - $t_{1/2}$ in s
 - V_{0m} in kn

Figure 5 — Time to half-value

6.5 Designation of a meander test

Designation of a meander test according to Part 5 (5), Test 1 (1) of this International Standard, conducted with an initial speed $V_0 = 10$ kn (10), a test stern plane angle $\Delta\delta_{Si} = 5^\circ$ (05), and an execute change of trim angle $\Delta\theta_E = 5^\circ$ (05):

Meander test ISO 13643-5.1 × 10/05/05

7 Test 5.2 — Vertical overshoot test

7.1 Description

A series of tests shall be conducted with different initial speeds, V_0 , test stern plane angles, $\Delta\delta_{Si}$, and execute change of trim angles, $\Delta\theta_E$.

For safety reasons, the series of tests shall be commenced with combinations of small values.

The submarine shall approach on a steady heading and at a constant speed, V_0 , before commencing the test. During the test, the propulsion plant settings must remain unaltered and the heading kept as constant as possible. Heading and rudder movements shall be recorded throughout the test (preferably at intervals of 1 s). If the submarine is equipped with planes acting simultaneously in the horizontal and the vertical direction (e.g. X-planes), these planes should be controlled in such a way that a steady heading is maintained as a matter of priority.

After the submarine has been moving ahead for at least two minutes without significant movements of rudder and planes, the stern planes are set to the specified test stern plane angle, $\Delta\delta_{Si}$, as fast as possible and held there until the trim angle has deviated from the initial trim angle, θ_{S0} , by the specified execute change of trim angle, $\Delta\theta_E$. At this point, the stern planes are reversed to the same test stern plane angle, $\Delta\delta_{Si}$, but in the opposite direction relative to the initial setting, and held until the submarine is levelled-off, i.e. the rate of change of dived depth reduces to zero.

This completes the test for the selected parameters.

7.2 Analysis and presentation of results of a vertical overshoot test

The following data are obtained from the test:

— response time	t_A
— overshoot time	t_C
— levelling-off time	t_t
— overshoot angle	θ_S
— response depth change	Δz_{0E}
— levelling-off depth change	Δz_{0M}

Together with the test parameters V_0 , $\Delta\delta_{Si}$, and $\Delta\theta_E$, the abovementioned data are used to assess the effectiveness of the stern planes.

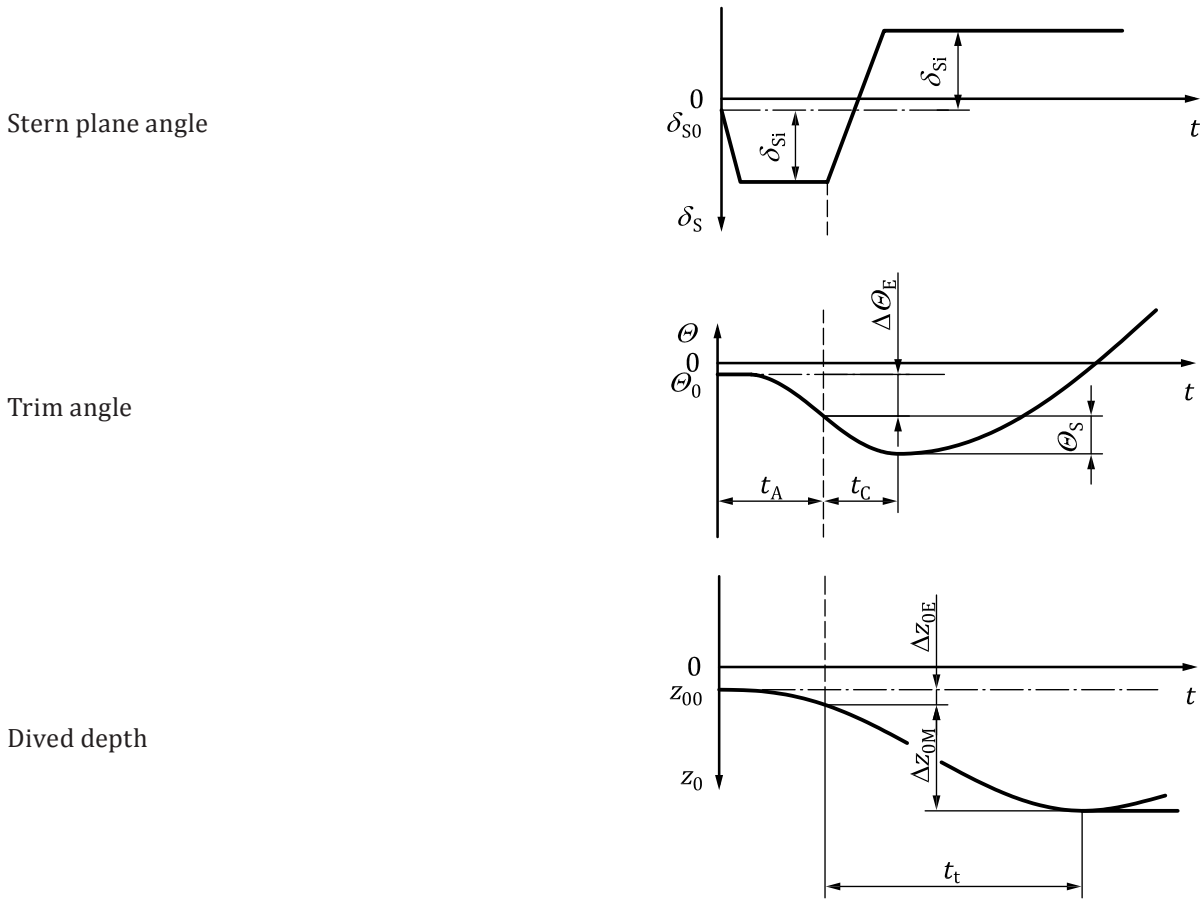

Figure 6 — Time history

7.3 Designation of a vertical overshoot test

Designation of a vertical overshoot test according to Part 5 (5), Test 2 (2) of this International Standard, conducted with an initial speed $V_0 = 10$ kn (10), a test stern plane angle $\Delta\delta_{Si} = 5^\circ$ (05), and an execute change of trim angle $\Delta\theta_E = 5^\circ$ (05):

Vertical overshoot test ISO 13643-5.2 × 10/05/05

8 Test 5.3 — Neutral level flight test

8.1 Description

8.1.1 Model test (M)

Moments and forces are measured at the supporting structure and recorded for the submerged submarine model, preferably initially on even keel when at a standstill with the stabilizing fins and stern planes set to $\delta_{SX} = 0$ and $\delta_S = 0$ (initial condition). Now the submarine model is accelerated to a test speed V_0 at which the bottom and surface effects are still negligible. Then, the changes of the vertical force and the trim moment relative to the initial condition are measured and recorded.

In successive test steps with other trims, the initial condition at standstill is to be determined again.

The angles of the stabilizing fins and the stern plane, as well as the trim angles or bow plane angles, have to be varied in suitable increments (for instance, trim angle increments of $0,5^\circ$, stabilizing fin/hydroplane angle increments of 1°). For stern planes with fixed post and movable part, it is recommended to set both to the same angle ($\delta_{SX} = \delta_S$). The angles have to be selected so as to provide positive and negative values for the quantities of the vertical force and the trim moment when one parameter is maintained (trim angle or hydroplane angle) so that the zero value may be interpolated for evaluation purposes.

The angle of the stabilizing fin and/or fixed post of stern planes derived from the model tests according to [8.2.1](#) serves as input for the detailed design. The trim angle and/or hydroplane angles at which the submarine is assumed to maintain a constant dived depth at all speeds should be ascertained by full-scale tests.

8.1.2 Full-scale test (S)

8.1.2.1 General

A submerged cruising condition is to be found at which not only the total force and the total moment but also the difference between weight and buoyancy and the static trim moment are zero. At relatively high speeds, the difference between weight and buoyancy and the static trim moment have almost no influence on the dynamic behaviour of the boat. Therefore, the neutral level flight condition can be determined comparatively simply by extrapolation.

8.1.2.2 Submarines with retractable bow planes

The submerged submarine is compensated at a speed of about twice the critical speed, V_{CR} (see [Clause 9](#)), by use of the trimming and compensating systems, so that depth keeping is possible with retracted bow planes at a stern plane angle between $\pm 1,5^\circ$ and a trim angle between -1° and 0° . The actual quantity and the centre of gravity of compensating water have to be measured and recorded.

After that, the submarine shall be kept on a constant dived depth by use of the stern planes. Approaches at test speeds, V_{0i} , of about 50 %, 60 %, 65 %, 75 %, and 90 % of the maximum speed are conducted successively. These test speeds, V_{0i} , are selected such that an almost even distribution of test stern plane angles, δ_S , and trim angles, θ_S , is obtained when plotted as a function of the inverse square of the test speed, V_0 . The test speed, V_{0i} , the related stern plane angle, δ_S , and the resulting trim angle, θ_S shall be recorded.

After evaluation as per [8.2.2.1](#), the test speed is set again to about twice the critical speed, V_{CR} . The submarine is trimmed and compensated until it finally maintains a constant depth with a stern plane angle, δ_{S0} , and trim angle, θ_{S0} , for neutral level flight determined by the evaluation. The quantity and the centre of gravity of compensating water shall be measured and recorded.

In order to verify the angles δ_{S0} and θ_{S0} for neutral level flight, the submarine speed will be increased in increments up to a speed, V_{0i} , of 75 % of the maximum speed without changing the setting of the stern planes. Dived depth and trim angle are to be measured and recorded at suitable time intervals. After that, the stern plane is used to maintain depth, if necessary. In case the stern plane angle δ_S or the

related change of trim angle θ_S differs by less than $0,2^\circ$ from the stern plane angle δ_{S0} and trim angle θ_{S0} , the test is completed.

Otherwise, the stern plane angle δ_S and the related change of trim angle θ_S for maintaining depth are to be determined at two additional speeds. The stern plane angles δ_S and the trim angles θ_S determined by the last three speeds together with the previously used angles for stern planes δ_{S0} and trim θ_{S0} are used for a renewed evaluation to determine the new values of δ_{S0} and θ_{S0} . After that, a further verification loop begins with compensating the submarine for a test speed of about twice the critical speed, V_{CR} .

8.1.2.3 Submarines with non-retractable bow planes

The submerged submarine is compensated at a speed of about twice the critical speed, V_{CR} , by use of the trimming and compensating systems so that depth keeping is possible for any pre-selected trim angle, θ_S (preferably $\theta_S = 0^\circ$), at a stern plane angle between $\pm 1,5^\circ$ and a bow plane angle between $\pm 4^\circ$. The actual quantity and centre of gravity of compensating water are to be measured and recorded.

After that, the submarine shall be kept on a constant dived depth at the pre-selected trim angle $\theta_S = \theta_{S0}$ by use of stern and bow planes. Approaches at test speeds, V_{0i} , of about 50 %, 60 %, 65 %, 75 %, and 90 % of the maximum speed are made successively. These test speeds, V_{0i} , shall be selected such that an almost even distribution of stern plane angles, δ_S , and bow plane angle, δ_B , is obtained when plotted as a function of the inverse square of the test speed, V_{0i} . The test speed, V_{0i} , the related stern plane angle, δ_S , and bow plane angle, δ_B , are to be recorded.

After evaluation as per [8.2.2.2](#), the test speed is set again to about twice the critical speed, V_{CR} . The submarine is trimmed and compensated until it finally maintains a constant depth with stern plane angle δ_{S0} and bow plane angle δ_{B0} determined by the evaluation for neutral level flight at trim angle $\theta_S = \theta_{S0}$. Quantity and centre of gravity of compensating water have to be measured and recorded.

In order to verify the angles δ_{S0} and δ_{B0} for neutral level flight, the submarine speed is increased in increments up to a speed, V_{0i} , of 75 % of the maximum speed without changing the settings of the stern and bow planes. Dived depth and trim angle are measured and recorded at suitable time intervals. After that, the stern and bow planes are used to maintain depth and trim angle θ_{S0} , if necessary. If it is determined that the stern plane angle, δ_S , or the bow plane angle, δ_B , differs by less than $0,2^\circ$ from the neutral level flight stern plane angle, δ_{S0} , and the neutral level flight bow plane angle, δ_{B0} , the test is completed.

Otherwise, the stern plane angle, δ_S , and the related bow plane angles, δ_B , for maintaining depth and trim angle, θ_{S0} , are to be determined at two additional speeds. The stern plane angles, δ_S , and the bow plane angles, δ_B , determined by the last three speeds, together with the previously used angles for stern planes, δ_{S0} , and bow planes, δ_{B0} , are used for a renewed evaluation to determine the new values of δ_{S0} and δ_{B0} . After that, a further verification loop begins with compensating the submarine for a test speed of about twice the critical speed, V_{CR} .

8.2 Analysis and presentation of results of a neutral level flight test

8.2.1 Model test

The vertical forces and trim moments according to [8.1.1](#) are plotted in a diagram as a function of the trim angle (or of the bow plane angle) for the different stern plane angles as parameters (Example: [Figures 7](#) and [8](#)) and as functions of the stern plane angle for the different trim angles (or of the bow plane angles) as parameters, respectively.

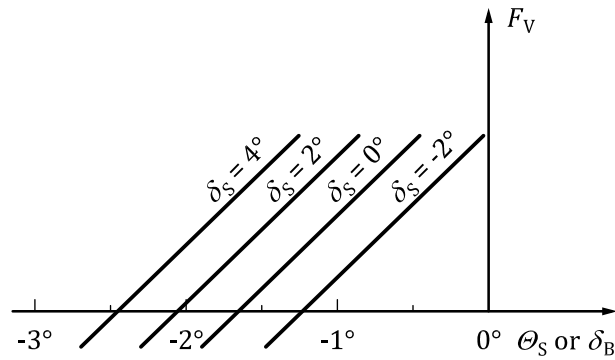

Key

F_V in N

Figure 7 — Vertical force

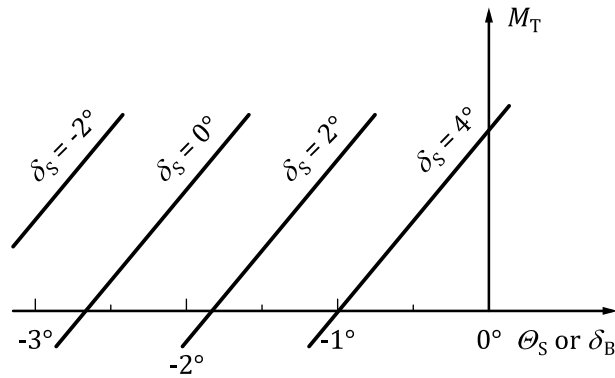

Key

M_T in Nm

Figure 8 — Trim moment

The stabilizing fin/stern plane angles and the trim angles or bow plane angles for zero values of the vertical force, F_V , and the trim moment, M_T , are taken and plotted as curves in one diagram. The result of the test, i.e. the stabilizing fin angle, δ_{SX0} , and the stern plane angle, δ_{S0} , and the trim angle, θ_{S0} , (or the bow plane angle, δ_{B0}) for neutral level flight is given from the intersection of the two curves (Example: [Figure 9](#)).

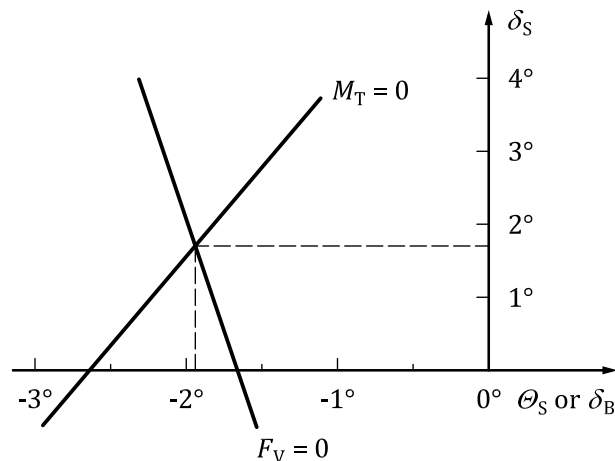

Key

$\delta_S, \theta_S, \delta_B$ in $^\circ$

Figure 9 — Analysis diagram

8.2.2 Full-scale test

8.2.2.1 Submarines with retractable bow planes

The values for δ_S and θ_S according to 8.1.2.2 are plotted in a diagram as a function of the inverse square of the test speed $1/V_0^2$. The values for δ_S and θ_S shall be determined by the following linear regression approximations.

$$\delta_S = \delta_{S0} + a_1 \frac{1}{V_0^2} + a_2 \frac{\theta_S}{V_0^2} \tag{1}$$

$$\theta_S = \theta_{S0} + b_1 \frac{1}{V_0^2} + b_2 \frac{\theta_S}{V_0^2} \tag{2}$$

δ_{S0} and θ_{S0} are the values of the extrapolated curves at $1/V_0^2 = 0$ (Example: [Figure 10](#)).

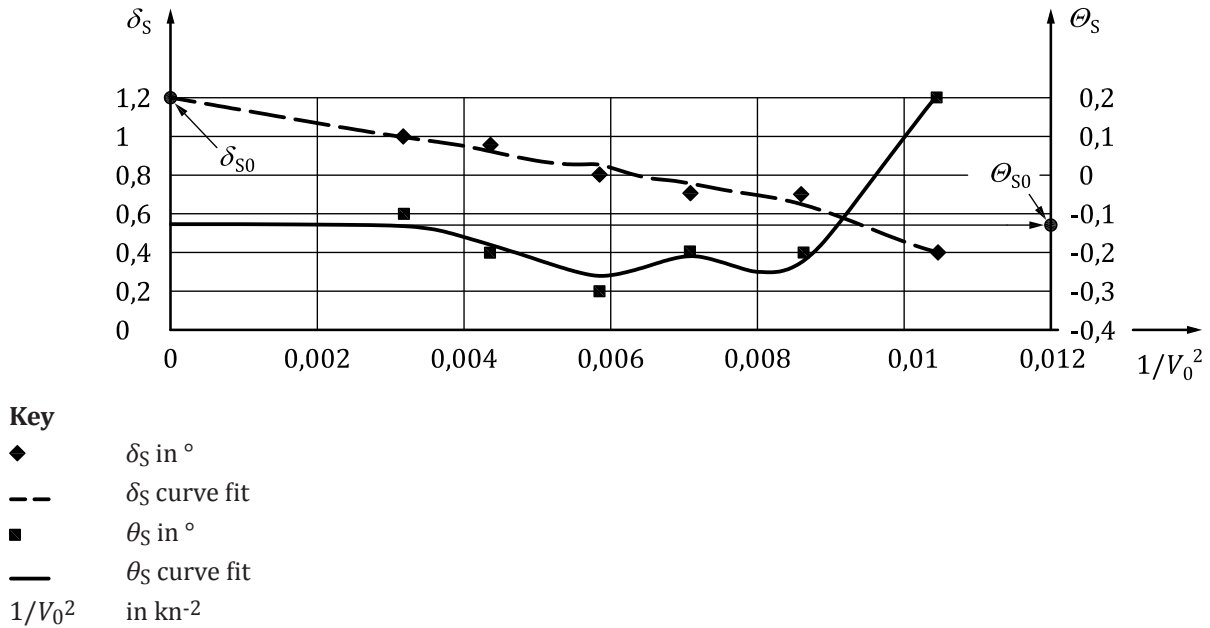

Figure 10 — Analysis diagram

8.2.2.2 Submarines with non-retractable bow planes

The values for δ_S and δ_B according to 8.1.2.3 are plotted in a diagram as a function of the inverse square of the test speed $1/V_0^2$ and approximated by the following linear equations.

$$\delta_S = \delta_{S0} + c_1 \frac{1}{V_0^2} \tag{3}$$

$$\delta_B = \delta_{B0} + d_1 \frac{1}{V_0^2} \tag{4}$$

δ_{S0} and δ_{B0} are the values of the extrapolated curves at $1/V_0^2 = 0$ (Example: Figure 11).

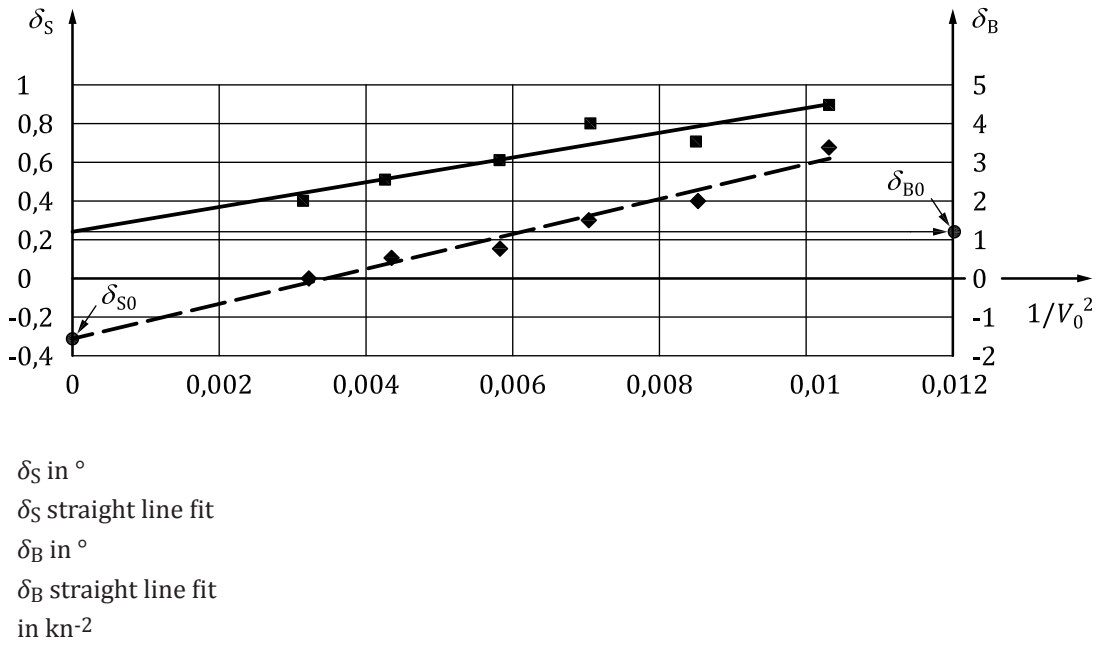

Figure 11 — Analysis diagram

8.3 Designation of a neutral level flight test

8.3.1 Designation of a neutral level flight test with the model (M)

Designation of a neutral level flight test according to Part 5 (5), Test 3 (3) of this International Standard, conducted with the model (M) at a test speed $V_0 = 9$ kn (09) (representative for full-scale):

Neutral level flight test ISO 13643-5.3 × 09/M

8.3.2 Designation of a neutral level flight test with the full-scale ship (S)

Designation of a neutral level flight test according to Part 5 (5), Test 3 (3) of this International Standard, conducted with the full-scale ship (S) at a test speed $V_0 = 9$ kn (09):

Neutral level flight test ISO 13643-5.3 × 09/S

The test speed as part of the designation is not applicable for an evaluation by extrapolation.

10

9 Test 5.4 — Critical speed test

9.1 General

Besides the general test conditions outlined in ISO 13643-1 and [Clause 5](#), the following specific test conditions shall be complied with:

- sufficient diving depth and water depth corresponding to the expected changes in depth;
- no change of bow plane angle.

The critical speed occurs in the low speed range. It depends on the stern plane angle, the static longitudinal stability, and the geometry of the submarine with its appendages.

For the individual runs, it is recommended to use several different initial speeds, V_0 , and stern plane angles, δ_{Si} , between $+10^\circ$ and -10° , resulting in positive and negative rates of depth change.

If the submarine is equipped with planes acting simultaneously into the horizontal and the vertical directions (e.g. X-planes), these planes should be controlled in such a way that a steady heading is maintained as a matter of priority.

During the test, including the initial phase, speed, plane angles, trim, and dived depth shall be recorded continuously (ideally at intervals of 1 s).

Submarines with bow planes arranged relatively far from the forward perpendicular may show a critical speed within the relevant speed range. Should a simulation recommend an investigation, such tests shall be performed in the same manner as those for the stern planes.

The submarine approaches at a constant speed, V_0 . During the test, the setting of the propulsion plant shall remain unaltered. The heading shall be kept as constant as possible and be recorded together with the rudder movements. The conditions of neutral level flight must not be changed.

9.2 Description

After the submarine has been moving ahead for at least two minutes without significant depth and heading changes, the stern plane is set to the selected test stern plane angle, δ_{Si} , as fast as possible. The run is completed when a constant trim is achieved for at least 60 s. If a constant trim is not achieved within 10 min, the run must be repeated with a smaller stern plane angle, δ_{Si} .

The constant trim is the indicator for a constant rate of depth change.

9.3 Analysis and presentation of results of a critical speed test

From the data measured, the constant rates of depth change, \dot{z}_{0F} , are determined with due consideration of possible corrections due to depth changes during the approach phase.

The rates of depth change, \dot{z}_{0F} , are plotted in a diagram as a function of stationary speed at the end of the test, V_F , for the respective stern plane angle, δ_{Si} (see [Figure 12](#)). The intersecting points of the curves with the abscissa ($\dot{z}_{0F} = 0$) indicate the critical speeds for the various stern plane angles, which are plotted in a diagram in accordance with [Figure 13](#). The intersecting point of the stern plane angle, δ_{Si} , with the abscissa, V_F , determines the critical speed for small stern plane angles.

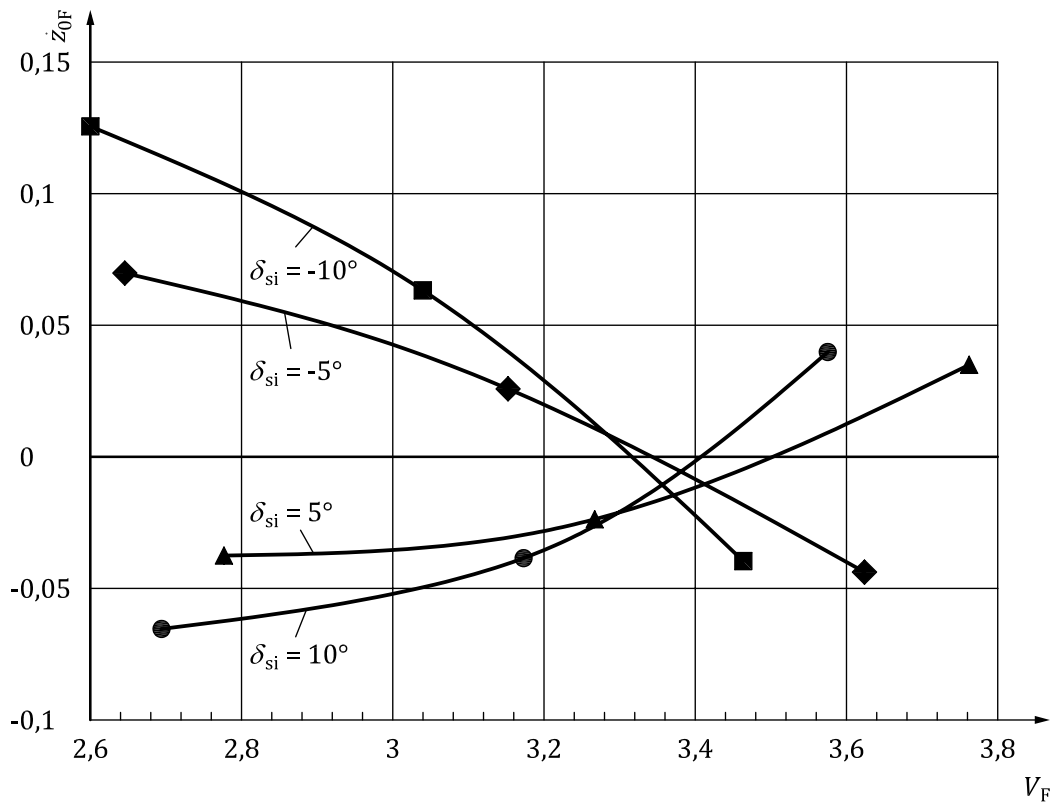

Key
 \dot{z}_{0F} in $m\ s^{-1}$
 V_F in kn

Figure 12 — Rate of depth change

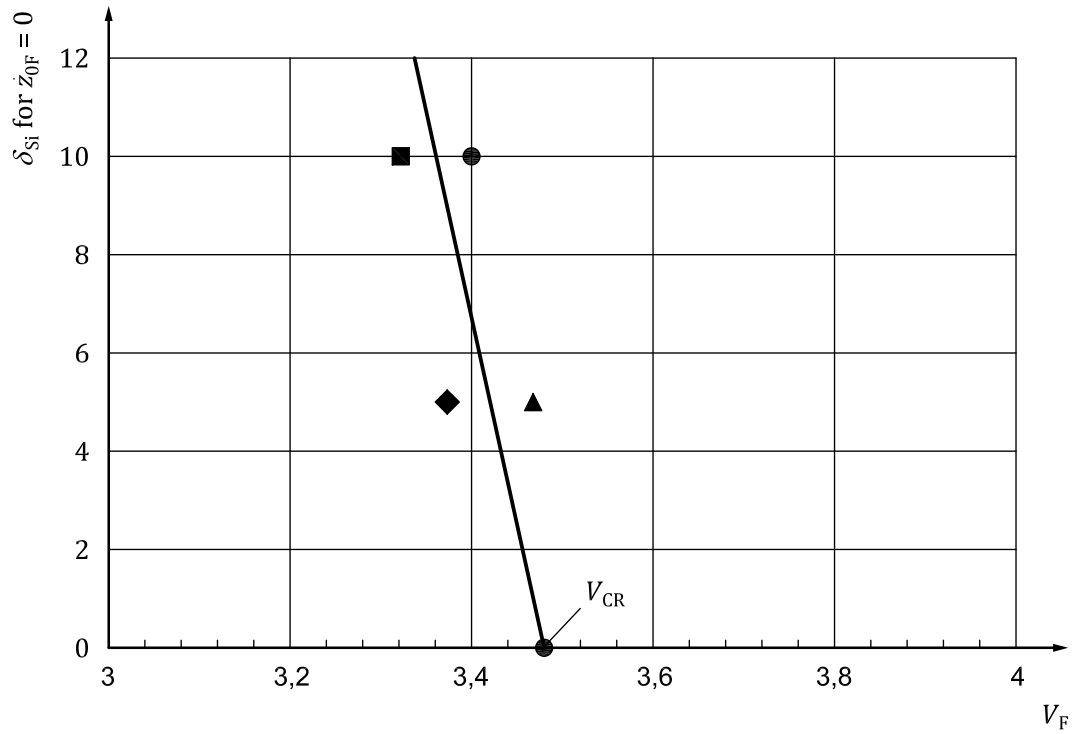

Key

δ_{Si} in $^\circ$
 V_F in kn

Figure 13 — Critical speed

9.4 Designation of a critical speed test

Designation of a critical speed test according to Part 5 (5), Test 4 (4) of this International Standard:

Critical speed test ISO 13643-5.4

Bibliography

- [1] ISO 13643-6, *Ships and marine technology — Manoeuvring of ships — Part 6: Model test specials*

.....

Vertical line of text, possibly a page number or reference, oriented vertically.

ICS 47.020.70

Price based on 22 pages