**Ships and marine technology —
Manoeuvring of ships —**

Part 4:
Stopping, acceleration, traversing

*Navires et technologie maritime — Manoeuvres des navires —
Partie 4: Arrêt, accélération, déplacement*





COPYRIGHT PROTECTED DOCUMENT

© ISO 2017, Published in Switzerland

All rights reserved. Unless otherwise specified, no part of this publication may be reproduced or utilized otherwise in any form or by any means, electronic or mechanical, including photocopying, or posting on the internet or an intranet, without prior written permission. Permission can be requested from either ISO at the address below or ISO's member body in the country of the requester.

ISO copyright office
Ch. de Blandonnet 8 • CP 401
CH-1214 Vernier, Geneva, Switzerland
Tel. +41 22 749 01 11
Fax +41 22 749 09 47
copyright@iso.org
www.iso.org

Contents

Page

Foreword	iv
1 Scope	1
2 Normative references	1
3 Terms and definitions	1
4 Test-related physical quantities	2
5 General test conditions	3
6 Test 4.1 — Stopping test	4
6.1 General	4
6.2 Description	4
6.3 Analysis and presentation of results of a stopping test	5
6.4 Designation of a stopping test	6
7 Test 4.2 — Coasting stop test (inertia test)	6
7.1 General	6
7.2 Description	6
7.3 Analysis and presentation of results of a coasting stop test	7
7.4 Designation of a coasting stop test	8
8 Test 4.3 — Acceleration test	8
8.1 General	8
8.2 Description	8
8.3 Analysis and presentation of results of an acceleration test	8
8.4 Designation of an acceleration test	9
9 Test 4.4 — Traversing test	9
9.1 General	9
9.2 Description	9
9.3 Analysis and presentation of results of a traversing test	9
9.4 Designation of a traversing test	10

Foreword

ISO (the International Organization for Standardization) is a worldwide federation of national standards bodies (ISO member bodies). The work of preparing International Standards is normally carried out through ISO technical committees. Each member body interested in a subject for which a technical committee has been established has the right to be represented on that committee. International organizations, governmental and non-governmental, in liaison with ISO, also take part in the work. ISO collaborates closely with the International Electrotechnical Commission (IEC) on all matters of electrotechnical standardization.

The procedures used to develop this document and those intended for its further maintenance are described in the ISO/IEC Directives, Part 1. In particular the different approval criteria needed for the different types of ISO documents should be noted. This document was drafted in accordance with the editorial rules of the ISO/IEC Directives, Part 2 (see www.iso.org/directives).

Attention is drawn to the possibility that some of the elements of this document may be the subject of patent rights. ISO shall not be held responsible for identifying any or all such patent rights. Details of any patent rights identified during the development of the document will be in the Introduction and/or on the ISO list of patent declarations received (see www.iso.org/patents).

Any trade name used in this document is information given for the convenience of users and does not constitute an endorsement.

For an explanation on the meaning of ISO specific terms and expressions related to conformity assessment, as well as information about ISO's adherence to the World Trade Organization (WTO) principles in the Technical Barriers to Trade (TBT) see the following URL: www.iso.org/iso/foreword.html.

The committee responsible for this document is ISO/TC 8, *Ships and marine technology*, Subcommittee SC 6, *Navigation and ship operations*.

This second edition cancels and replaces the first edition (ISO 13643-4:2013), of which it constitutes a minor revision with the following changes:

- the numbering has changed;
- in [Clause 4, Table 1](#), in the second line of the table (CC-Code DECFAC), the Definition was changed;
- in [Clause 4, Table 1](#), in line 9 of the table (CC-Code TIACC), the SI-Unit was changed from “m” to “s”.

A list of all parts in the ISO 13643 series can be found on the ISO website.

Ships and marine technology — Manoeuvring of ships —

Part 4: Stopping, acceleration, traversing

1 Scope

This document defines symbols and terms and provides guidelines for the conduct of tests to give evidence about the stopping, acceleration, and traversing of surface ships, submarines, and models. It is intended to be read in conjunction with ISO 13643-1.

2 Normative references

The following documents are referred to in the text in such a way that some or all of their content constitutes requirements of this document. For dated references, only the edition cited applies. For undated references, the latest edition of the referenced document (including any amendments) applies.

ISO 13643-1, *Ships and marine technology — Manoeuvring of ships — Part 1: General concepts, quantities and test conditions*

ISO 13643-5:2017, *Ships and marine technology — Manoeuvring of ships — Part 5: Submarine specials*

ISO 80000-1, *Quantities and units — Part 1: General*

ISO 80000-3, *Quantities and units — Part 3: Space and time*

IMO MSC Circular 1053, *Explanatory Notes to the Standard for Ship Manoeuvrability*

3 Terms and definitions

For the purposes of this document, the following terms and definitions apply.

ISO and IEC maintain terminological databases for use in standardization at the following addresses:

— IEC Electropedia: available at <http://www.electropedia.org/>

— ISO Online browsing platform: available at <https://www.iso.org/obp/>

3.1

acceleration test

manoeuvring test to determine the ship's performance under positive acceleration or negative acceleration (deceleration)

3.2

coasting stop test

manoeuvring test to determine the ship's behaviour after the propulsion plant has been disengaged and/or shut down

3.3

manoeuvring device

rudder, azimuthing thruster, hydroplane, cycloidal propeller, or equivalent system used to manoeuvre a vessel

**3.4
stopping test**

manoeuvring test to determine the ship's behaviour after active reversal of the thrust direction of the propulsion plant

**3.5
traversing test**

manoeuvring test to determine the ship's capability to execute a lateral movement, if possible without turning and moving in the longitudinal direction

4 Test-related physical quantities

Test-related physical quantities are listed in [Table 1](#). The more general quantities and concepts concerning the manoeuvring of ships are set out in ISO 13643-1.

For quantities and their units, ISO 80000-1 and ISO 80000-3 shall be used.

Table 1 — Test-related physical quantities

Symbol	CC-Code	SI-Unit	Concept	
			Term	Definition or explanation
s_F	SPF	m	Track reach	Distance travelled from $t = 0$ up to the time the ship is "practically dead in the water" measured along the ship's track
$\frac{s_F}{V_0}$	DECFAC	s^a	Track reach deceleration factor	Average time to decelerate by one knot
s_S	SPS	m	Track reach to propulsor stop	If the propulsion is shut down, distance travelled along the ship's track before the propulsion has come to a complete stop
s_a	SPACC	m	Acceleration distance	Distance travelled along the ship's track before the target speed is achieved
$s_{(t)min}$	SP(t)	m	Track reach after (t) minutes	(t) stands for elapsed time after $t = 0$, example: track reach after 3 minutes: s_{3min} or SP3
t_F	TIF	s	Stopping time	For stopping test: From $t = 0$ to the time when the ship is "dead in the water"
			Coasting time	For coasting stop test: From $t = 0$ to the time when the ship is "practically dead in the water" ($V \leq 2$ kn)
t_S	TIS	s	Time to propulsor stop	If the propulsion is shut down, the time until the propulsion has come to a complete stop
t_U	TIU	s	Reversal time	Until full astern power is achieved
t_a	TIACC	s	Acceleration time	Time elapsed to achieve the target speed (within a margin of 1 kn)
V_L	VL	$m\ s^{-1\ b}$	Steerage way	Speed down to which the ship still follows the manoeuvring devices
V_i	VI	$m\ s^{-1\ b}$	Target speed	Speed to which the ship is accelerated or decelerated
V_{x0}	VX0	$m\ s^{-1\ b}$	Advance speed	Component in x_0 -direction, relative to the initial heading of the ship

^a The unit m/kn may be used.

^b The unit kn, common in navigation, may be used.

^c For angles, the unit ° (degree), may be used.

Table 1 (continued)

Symbol	CC-Code	SI-Unit	Concept	
			Term	Definition or explanation
V_{y0}	VY0	m s ⁻¹ ^b	Traversing speed	Component in y_0 -direction, relative to the initial heading of the ship
V_0	V0	m s ⁻¹ ^b	Initial speed	(See ISO 13643-1)
x_0	X0	m	—	Coordinate in the direction of initial heading in the earth-fixed axis system moving with the water, the origin of which coincides with that of the ship-fixed axis system at $t = 0$ (see also ISO 13643-1)
x_{0F}	X0F	m	Advance at end of test (run)	x_0 -component of ship's track at t_F
y_0	Y0	m	Transverse axis	Coordinate in the water surface perpendicular to x_0 , analogous definition (see also ISO 13643-1)
y_{0F}	Y0F	m	Transfer at end of test (run)	y_0 -component of the ship's track at t_F
z_0	Z0	m	Vertical axis	Coordinate of the earth fixed axis system orthogonal to x_0 and y_0 vertically down, analogous definition (see ISO 13643-1)
z_0	Z0	m	Dived depth	—
β	BET	rad ^c	Drift angle	(See ISO 13643-1)
Δz_{0F}	DZ0F	m	Change of dived depth	z_0 -component of the ship's track at t_F relative to value at the commencement of a test (run)
$\Delta\psi$	DPSIH	rad ^c	Change of heading	$\psi - \psi_0$
$\Delta\psi_F$	DPSIHF	rad ^c	Change of heading at end of test (run)	$\psi_F - \psi_0$
ψ	PSIH	rad ^c	Heading	(See ISO 13643-1)
ψ_F	PSIHF	rad ^c	Final heading	Heading at the end of a test (run)
ψ_0	PSIH0	rad ^c	Initial heading	Heading of a vessel at the commencement of a test (run)
^a The unit m/kn may be used. ^b The unit kn, common in navigation, may be used. ^c For angles, the unit ° (degree), may be used.				

5 General test conditions

When operating submerged, submarines shall be trimmed according to the results of the neutral level flight test (see ISO 13643-5:2017, Clause 8). During the test, the dived depth shall be kept as constant as possible. The dived depth and the plane angles are to be recorded continuously. If the submarine is equipped with planes acting in the horizontal as well as the vertical direction at the same time (e.g. X-planes), these planes should be controlled in a way that a steady dived depth is maintained as matter of priority.

During the test, including the approach phase, each successive position of the ship is to be recorded, e.g. using an onboard navigation system during surface operations, at suitable time intervals (usually every second).

The reference point on the ship relative to which its track is measured should be defined in advance (e.g. location of the positioning system antenna). This point is not necessarily identical with the origin of the ship-fixed axis system for which the ship's track is given (see ISO 13643-1). Data which are to be recorded continuously include (but need not be limited to) manoeuvring device setting, propulsion setting, speed through the water, heading, rate of turn, heel angle, true wind velocity and direction, and relative wind velocity and direction.

6 Test 4.1 — Stopping test

6.1 General

The general test conditions outlined in ISO 13643-1 and [Clause 5](#) shall be complied with.

6.2 Description

The ship approaches at a constant speed, V_0 .

After the ship has been going straight ahead at the specified speed without significant application of the manoeuvring devices for at least two minutes, the active reversal of the thrust of the propulsion system is initiated ($t = 0$). Usually, this is achieved by reversing the propulsion to full astern. The ship shall be kept on its initial heading for as long as possible.¹⁾ If the ship no longer responds to the manoeuvring device, the device is returned to and held amidships (see [Figure 1](#)). In the case of a multi-shaft/-engine system, the different modes of operation and settings shall be observed.

Data which is to be recorded continuously includes (but need not be limited to) manoeuvring device angle, power setting, speed through the water, heading, rate of turn, propeller shaft speed/torque, propeller pitch, true wind velocity and direction, and relative wind velocity and direction. In addition, if possible, the thrust in the thrust bearing and the torque are to be recorded continuously.

The test is complete when the ship is dead in the water (see [Figure 1](#)). Deviating conditions for the end of the test shall be recorded.

NOTE If the test is performed from maximum continuous speed and with the maximum reverse thrust, it is designated as a “crash-stop”.

1) According to IMO MSC/Circ. 1053, the manoeuvring device shall be held amidships after reversing thrust.

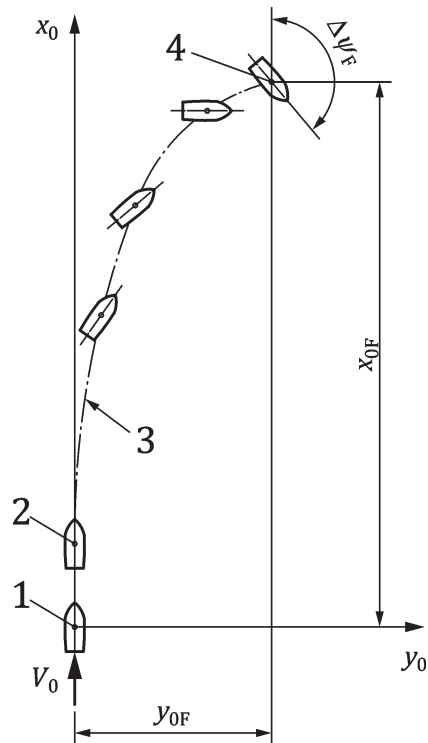
**Key**

- 1 thrust reversal initiated, $t = 0$
- 2 full astern power achieved, $t = t_U$
- 3 the ship's track (track reach, s_F , measured along the track)
- 4 ship dead in the water

Figure 1 — Stopping test**6.3 Analysis and presentation of results of a stopping test**

The following data are obtained from the test:

- | | |
|---|--|
| — track reach | s_F |
| — stopping time | t_F |
| — reversal time | t_U |
| — advance at end of test | x_{0F} |
| — transfer at end of test | y_{0F} |
| — change of dived depth | Δz_{0F} |
| — change of heading at end of test | $\Delta\psi_F$ |
| — track reach deceleration factor | $\frac{s_F}{V_0}$ |
| — track reach after (t) minutes, e.g. 1 min, 2 min, 3 min | $s_{1\text{min}}, s_{2\text{min}}, s_{3\text{min}}, \dots$ |

These data, together with the initial speed, V_0 , the plot of the ship's track, and a graphical representation of the time histories of speed, propeller speed and pitch, true wind velocity and direction, as well as manoeuvring device/hydroplane angles, are used for assessing the stopping performance.

6.4 Designation of a stopping test

Designation of a stopping test according to ISO 13643-4 (6), Test 1 (1), carried out with an initial speed $V_0 = 17$ kn (17):

Stopping test ISO 13643 – 4.1 × 17

A stopping test undertaken under the same conditions as above, however, following IMO Circ. 1053, shall be designated:

Stopping test ISO 13643 – 4.1 × 17 (IMO)

7 Test 4.2 — Coasting stop test (inertia test)

7.1 General

In addition to the general test conditions outlined in ISO 13643-1 and [Clause 5](#), the following condition shall be complied with.

- The ship approaches at a constant speed, V_0 .

7.2 Description

After the ship has been going straight ahead at the specified speed without significant application of the manoeuvring devices for at least two minutes, the propulsion system is disengaged and/or shut down ($t = 0$). The ship shall be kept on its initial heading for as long as possible.²⁾ If the ship no longer responds to the manoeuvring device, the device is returned to and held amidships (see [Figure 2](#)). The speed at which this occurs is termed “steerage way”, V_L .

The test is complete when the ship is practically dead in the water ($V \leq 2$ kn) (see [Figure 2](#)). The amount by which the ship has deviated from both initial track and heading shall be recorded. If the test completes in a different manner, the relevant conditions (environment and ship's behaviour) shall be recorded.

2) According to IMO MSC/Circ. 1053, the manoeuvring device shall be held amidships after stopping the propulsion.

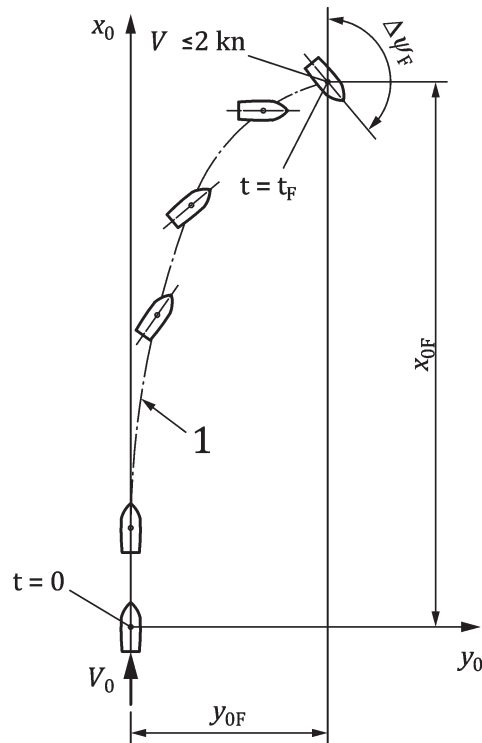
**Key**

- 1 ship's track (track reach, s_F , measured along the track)

Figure 2 — Coasting stop test

7.3 Analysis and presentation of results of a coasting stop test

The following data are obtained from the test; if practicable, the effects of wind and current shall be eliminated as necessary:

- | | |
|---|--|
| — track reach | s_F |
| — coasting time | t_F |
| — steerage way | V_L |
| — advance at end of test | x_{0F} |
| — transfer at end of test | y_{0F} |
| — change of dived depth | Δz_{0F} |
| — change of heading at end of test | $\Delta\psi_F$ |
| — track reach deceleration factor | $\frac{s_F}{V_0}$ |
| — track reach after (t) minutes, e.g. 1 min, 2 min, 3 min | $s_{1\text{min}}, s_{2\text{min}}, s_{3\text{min}}, \dots$ |

These data, together with the initial speed, V_0 , the plot of the ship's track, and a graphical representation of the time histories of speed, propeller speed and pitch, and manoeuvring device/hydroplane angles are used for assessing the coasting performance.

7.4 Designation of a coasting stop test

Designation of a coasting stop test according to ISO 13643-4 (6), Test 2 (2), carried out with an initial speed of $V_0 = 10$ kn (10):

Coasting stop test ISO 13643 – 4.2 × 10

A coasting stop test undertaken under the same conditions as above, but following IMO Circ. 1053, shall be designated:

Coasting stop test ISO 13643 – 4.2 × 10 (IMO)

8 Test 4.3 — Acceleration test

8.1 General

The general test conditions outlined in ISO 13643-1 and [Clause 5](#) shall be complied with.

8.2 Description

Usually, this test is intended to determine the shortest possible acceleration time as well as the distance covered during the period of acceleration achievable with the ship's propulsion system. In general, the time measured is for the acceleration from 0 kn to maximum achievable speed. However, there are classes of vessels which will require more extensive information regarding acceleration, and deceleration, performance necessitating more comprehensive tests. In the case of a multi-shaft/-engine system, the test may need to be repeated for each combination of shafts and settings.

The test is conducted moving straight ahead. After the vessel has maintained zero speed, or the intended approach speed, for at least two minutes, the propulsion plant is set to the pre-determined test setting ($t = 0$). During the test, movements of manoeuvring devices/planes should be kept to a minimum sufficient to maintain heading and depth. The test is complete when the ship has achieved the required target speed where the speed change in one minute is not more than 2 % of the target speed (for an acceleration test) or the speed change in one minute is not more than 2 % of the initial speed (for a deceleration test). The time taken to achieve the target speed, measured from t_0 , is the "acceleration time", t_a . The distance covered during that time is the "acceleration distance", s_a .

During the test, including the approach phase, each successive position of the vessel shall be recorded, e.g. using an onboard navigation system during surface operations, at suitable time intervals (usually every second). The reference point on the vessel from where its track is measured should be defined in advance (e.g. location of a positioning system antenna). This point is not necessarily identical with the origin of the ship-fixed axis system for which the vessel's track is given (see ISO 13643-1). Data which are to be recorded continuously include (but need not be limited to) manoeuvring device angle of operation, power setting, speed through the water, heading, rate of turn, heel angle, propeller shaft speed/torque, propeller pitch, true wind velocity and direction, and relative wind velocity and direction. In addition, if possible, the thrust in the thrust bearing shall be recorded continuously.

8.3 Analysis and presentation of results of an acceleration test

The following data are obtained from the test:

- acceleration time t_a
- acceleration distance s_a

8.4 Designation of an acceleration test

Designation of an acceleration test according to ISO 13643-4 (6), Test 3 (3), carried out with an initial speed of $V_0 = 0$ kn (0) and target speed of $V_i = 30$ kn (30):

Acceleration test ISO 13643 – 4.3 × 0/30

Designation of a negative acceleration (deceleration) test according to ISO 13643-4 (6), Test 3 (3), carried out with an initial speed of $V_0 = 21$ kn (21) and target speed of $V_i = 10$ kn (10):

Acceleration test ISO 13643 – 4.3 × 21/10

9 Test 4.4 — Traversing test

9.1 General

The general test conditions outlined in ISO 13643-1 and [Clause 5](#) shall be complied with.

9.2 Description

Ideally, in order to derive the most useful information, this test should be conducted in an area where tidal streams or currents are negligible. Runs should be conducted both into and downwind to establish the effect of wind on the manoeuvre and, particularly, leeway.

When wind conditions will prevent a reasonable traverse in either direction, the test should not be attempted.

The test is commenced from speed zero $V_0 = 0$ kn (vessel dead in the water). The ship shall be accelerated to the maximum possible steady lateral speed by means of manoeuvring devices and/or propulsion system with as little turning or longitudinal motion as possible. In the case of a multi-shaft/-engine system, the test may need to be repeated for each combination of shafts and settings.

During the test, each successive position of the vessel is to be recorded, e.g. using an onboard navigation system during surface operations, at suitable time intervals (usually every second). The reference point on the vessel from where its track is measured should be defined in advance (e.g. location of a positioning system antenna). This point is not necessarily identical with the origin of the ship-fixed axis system for which the vessel's track is given (see ISO 13643-1). Data which are to be recorded continuously include (but need not be limited to) manoeuvring device angle of operation, power settings, speed through the water, heading, propeller shaft speed/torque, propeller pitch, true wind velocity and direction, and relative wind velocity and direction.

This description is equally valid for both ships and models.

9.3 Analysis and presentation of results of a traversing test

From the track measurement, time histories are to be determined of:

- speed in x_0 -direction V_{x0}
- speed in y_0 -direction V_{y0}
- drift angle β
- heading ψ

These data are used to assess the traversing capability together with the records of the operation modes of manoeuvring devices, propulsors, and thrusters, as well as with those of the true wind velocity and direction.

9.4 Designation of a traversing test

Designation of a traversing test according to ISO 13643-4 (6), Test 4 (4):

Traversing test ISO 13643 - 4.4

