

---

---

**Aerospace — Inserts, self-locking,  
with MJ threads, open type, in metallic  
material, coated or uncoated — Dimensions**

*Aéronautique et espace — Douilles filetées, à freinage interne et filetage  
MJ, du type ouvert, en matériau métallique, revêtues ou non revêtues —  
Dimensions*



Reference number  
ISO 13597:2000(E)

© ISO 2000

**PDF disclaimer**

This PDF file may contain embedded typefaces. In accordance with Adobe's licensing policy, this file may be printed or viewed but shall not be edited unless the typefaces which are embedded are licensed to and installed on the computer performing the editing. In downloading this file, parties accept therein the responsibility of not infringing Adobe's licensing policy. The ISO Central Secretariat accepts no liability in this area.

Adobe is a trademark of Adobe Systems Incorporated.

Details of the software products used to create this PDF file can be found in the General Info relative to the file; the PDF-creation parameters were optimized for printing. Every care has been taken to ensure that the file is suitable for use by ISO member bodies. In the unlikely event that a problem relating to it is found, please inform the Central Secretariat at the address given below.

© ISO 2000

All rights reserved. Unless otherwise specified, no part of this publication may be reproduced or utilized in any form or by any means, electronic or mechanical, including photocopying and microfilm, without permission in writing from either ISO at the address below or ISO's member body in the country of the requester.

ISO copyright office  
Case postale 56 • CH-1211 Geneva 20  
Tel. + 41 22 749 01 11  
Fax + 41 22 734 10 79  
E-mail [copyright@iso.ch](mailto:copyright@iso.ch)  
Web [www.iso.ch](http://www.iso.ch)

Printed in Switzerland

## Foreword

ISO (the International Organization for Standardization) is a worldwide federation of national standards bodies (ISO member bodies). The work of preparing International Standards is normally carried out through ISO technical committees. Each member body interested in a subject for which a technical committee has been established has the right to be represented on that committee. International organizations, governmental and non-governmental, in liaison with ISO, also take part in the work. ISO collaborates closely with the International Electrotechnical Commission (IEC) on all matters of electrotechnical standardization.

International Standards are drafted in accordance with the rules given in the ISO/IEC Directives, Part 3.

Draft International Standards adopted by the technical committees are circulated to the member bodies for voting. Publication as an International Standard requires approval by at least 75 % of the member bodies casting a vote.

Attention is drawn to the possibility that some of the elements of this International Standard may be the subject of patent rights. ISO shall not be held responsible for identifying any or all such patent rights.

International Standard ISO 13597 was prepared by Technical Committee ISO/TC 20, *Aircraft and space vehicles*, Subcommittee SC 4, *Aerospace fastener systems*.



# Aerospace — Inserts, self-locking, with MJ threads, open type, in metallic material, coated or uncoated — Dimensions

## 1 Scope

This International Standard specifies the dimensions of open inserts, with self-locking MJ threads, in metallic material, coated or uncoated, for honeycomb and composite materials. The classification referring to strength and temperature, depending on the core material and potting compound, is not specified.

This International Standard is only applicable to the compilation of aerospace product standards.

## 2 Normative reference

The following normative document contains provisions which, through reference in this text, constitute provisions of this International Standard. For dated references, subsequent amendments to, or revisions of, any of these publications do not apply. However, parties to agreements based on this International Standard are encouraged to investigate the possibility of applying the most recent edition of the normative document indicated below. For undated references, the latest edition of the normative document referred to applies. Members of ISO and IEC maintain registers of currently valid International Standards.

ISO 5855-2:1999, *Aerospace — MJ threads — Part 2: Limit dimensions for bolts and nuts*.

## 3 Configuration and dimensions

See Figure 1 and Table 1. Dimensions and tolerances are expressed in millimetres. They apply to inserts after any surface coating(s).

12,5 / (3,2 / )<sup>a</sup>

Remove sharp edges 0,1 to 0,4

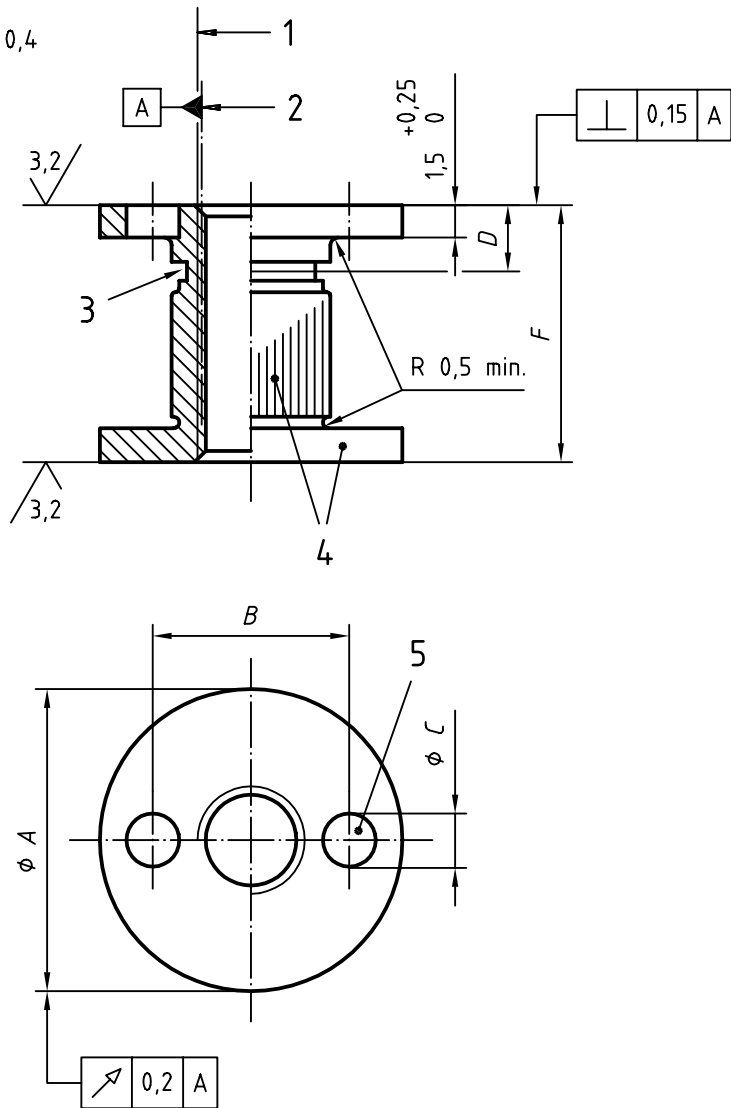

Details of form not stated are at the manufacturer's discretion.

- Key**
- 1 Thread
  - 2 Pitch diameter
  - 3 Shank deformed this area to provide thread lock
  - 4 Antirotation feature at manufacturer's option on shank or bottom flange
  - 5 Potting and vent hole
- <sup>a</sup> These values, in micrometres, are valid prior to any surface coating(s). The values do not apply to threads having a surface texture obtained by usual manufacturing methods.

Figure 1

Table 1

Diameter code	Thread <sup>a</sup>	A	B	C	D	E <sup>b,c</sup>	
		± 0,25	± 0,25	± 0,25	≈	nom.	tol.
<b>030</b>	MJ3 × 0,5-4H6H	14,2	9,3	2,4	3	7 to 30	+ 0,25 0
<b>040</b>	MJ4 × 0,7-4H6H				4	8 to 40	
<b>050</b>	MJ5 × 0,8-4H6H				5	10 to 50	
<b>060</b>	MJ6 × 1-4H5H				6	12 to 60	

<sup>a</sup> In accordance with ISO 5855-2  
<sup>b</sup> Increments: 1  
<sup>c</sup> Other height values to be agreed

**4 Example of application**

See Figure 2.

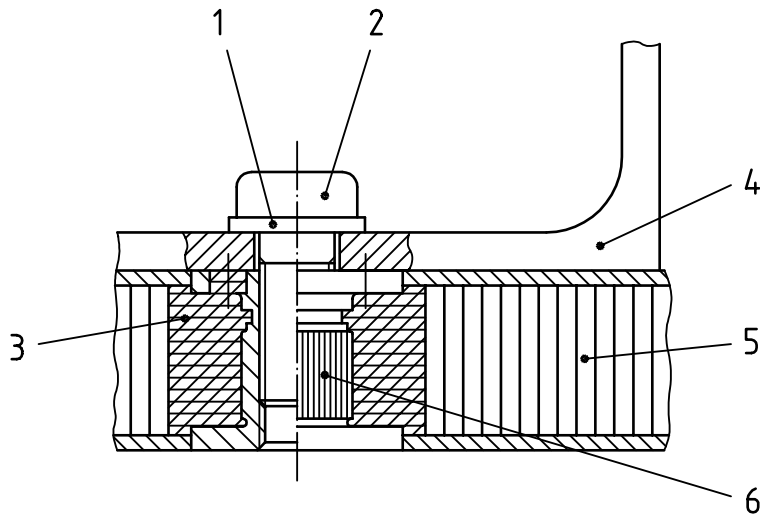

**Key**

- 1 Washer
- 2 Bolt
- 3 Potting compound
- 4 Attached component
- 5 Sandwich panel
- 6 Insert

**Figure 2**

---

---

**ICS 49.030.99**

Price based on 3 pages

© ISO 2000 – All rights reserved