

---

---

**Non-destructive testing of welds —  
Ultrasonic testing — Use of automated  
phased array technology**

*Contrôle non destructif des assemblages soudés — Contrôle par  
ultrasons — Utilisation de la technique multi-éléments automatisés*





**COPYRIGHT PROTECTED DOCUMENT**

© ISO 2012

All rights reserved. Unless otherwise specified, no part of this publication may be reproduced or utilized in any form or by any means, electronic or mechanical, including photocopying and microfilm, without permission in writing from either ISO at the address below or ISO's member body in the country of the requester.

ISO copyright office  
Case postale 56 • CH-1211 Geneva 20  
Tel. + 41 22 749 01 11  
Fax + 41 22 749 09 47  
E-mail [copyright@iso.org](mailto:copyright@iso.org)  
Web [www.iso.org](http://www.iso.org)

Published in Switzerland

# Contents

Page

Foreword .....	iv
<b>1 Scope .....</b>	<b>1</b>
<b>2 Normative references .....</b>	<b>1</b>
<b>3 Terms and definitions .....</b>	<b>2</b>
<b>4 Testing levels .....</b>	<b>2</b>
<b>5 Information required prior to testing .....</b>	<b>4</b>
5.1 Items to be defined prior to procedure development .....	4
5.2 Specific information required by the operator before testing .....	4
5.3 Written test procedure .....	4
<b>6 Requirements for personnel and equipment .....</b>	<b>5</b>
6.1 Personnel qualifications .....	5
6.2 Equipment .....	5
<b>7 Preparation for testing .....</b>	<b>5</b>
7.1 Volume to be inspected .....	5
7.2 Verification of test set-up .....	6
7.3 Scan increment setting .....	6
7.4 Geometry considerations .....	6
7.5 Preparation of scanning surfaces .....	6
7.6 Temperature .....	6
7.7 Couplant .....	6
<b>8 Testing of base material .....</b>	<b>7</b>
<b>9 Range and sensitivity settings .....</b>	<b>7</b>
9.1 Settings .....	7
9.2 Checking of the settings .....	8
9.3 Reference blocks .....	8
<b>10 Equipment checks .....</b>	<b>9</b>
<b>11 Procedure qualification .....</b>	<b>9</b>
<b>12 Weld testing .....</b>	<b>9</b>
<b>13 Data storage .....</b>	<b>10</b>
<b>14 Interpretation and analysis of phased array data .....</b>	<b>10</b>
14.1 General .....	10
14.2 Assessing the quality of the phased array data .....	10
14.3 Identification of relevant indications .....	10
14.4 Classification of relevant indications .....	10
14.5 Determination of location and length of an indication .....	11
14.6 Indication assessment .....	11
14.7 Evaluation against acceptance criteria .....	11
<b>15 Test report .....</b>	<b>11</b>
<b>Annex A (informative) Typical reference blocks and reference reflectors .....</b>	<b>13</b>
<b>Bibliography .....</b>	<b>17</b>

## Foreword

ISO (the International Organization for Standardization) is a worldwide federation of national standards bodies (ISO member bodies). The work of preparing International Standards is normally carried out through ISO technical committees. Each member body interested in a subject for which a technical committee has been established has the right to be represented on that committee. International organizations, governmental and non-governmental, in liaison with ISO, also take part in the work. ISO collaborates closely with the International Electrotechnical Commission (IEC) on all matters of electrotechnical standardization.

International Standards are drafted in accordance with the rules given in the ISO/IEC Directives, Part 2.

The main task of technical committees is to prepare International Standards. Draft International Standards adopted by the technical committees are circulated to the member bodies for voting. Publication as an International Standard requires approval by at least 75 % of the member bodies casting a vote.

Attention is drawn to the possibility that some of the elements of this document may be the subject of patent rights. ISO shall not be held responsible for identifying any or all such patent rights.

ISO 13588 was prepared by the European Committee for Standardization (CEN) in collaboration with ISO Technical Committee TC 44, *Welding and allied processes*, Subcommittee SC 5, *Testing and inspection of welds*, in accordance with the Agreement on technical cooperation between ISO and CEN (Vienna Agreement).

Requests for official interpretations of any aspect of this International Standard should be directed to the Secretariat of ISO/TC 44/SC 5 via your national standards body. A complete listing of these bodies can be found at [www.iso.org](http://www.iso.org).

# Non-destructive testing of welds — Ultrasonic testing — Use of automated phased array technology

## 1 Scope

This International Standard specifies the application of the phased array technology for the semi- or fully automated ultrasonic testing of fusion-welded joints in metallic materials of minimum thickness 6 mm. It applies to full penetration welded joints of simple geometry in plates, pipes, and vessels, where both the weld and parent material are low-alloyed carbon steel.

Where material-dependent ultrasonic parameters are specified in this International Standard, they are based on steels having an ultrasonic sound velocity of  $(5\,920 \pm 50)$  m/s for longitudinal waves, and  $(3\,255 \pm 30)$  m/s for transverse waves. It is necessary to take this fact into account when examining materials with a different velocity.

This International Standard provides guidance on the specific capabilities and limitations of phased array technology for the detection, location, sizing and characterization of discontinuities in fusion-welded joints. Phased array technology can be used as a stand-alone technology or in combination with other non-destructive testing (NDT) methods or techniques, for manufacturing inspection, pre-service and for in-service inspection.

This International Standard specifies four testing levels, each corresponding to a different probability of detection of imperfections.

This International Standard permits assessment of indications for acceptance purposes based on either amplitude (equivalent reflector size) and length or height and length.

This International Standard does not include acceptance levels for discontinuities.

This International Standard is not applicable:

- for coarse-grained metals and austenitic welds;
- for automated testing of welds during the production of steel products covered by ISO 10893-8,<sup>[3]</sup> ISO 10893-11,<sup>[4]</sup> and ISO 3183.<sup>[1]</sup>

## 2 Normative references

The following referenced documents are indispensable for the application of this document. For dated references, only the edition cited applies. For undated references, the latest edition of the referenced document (including any amendments) applies.

ISO 9712, *Non-destructive testing — Qualification and certification of NDT personnel*

ISO 10863, *Non-destructive testing of welds — Ultrasonic testing — Use of time-of-flight diffraction technique (TOFD)*

ISO 17635, *Non-destructive testing of welds — General rules for metallic materials*

ISO 17640, *Non-destructive testing of welds — Ultrasonic testing — Techniques, testing levels, and assessment*

EN 473, *Non-destructive testing — Qualification and certification of NDT personnel — General principles*

EN 1330-4, *Non-destructive testing — Terminology — Part 4: Terms used in ultrasonic testing*

EN 16392-1, *Non-destructive testing — Characterization and verification of ultrasonic phased array systems — Part 1: Instruments*

EN 16392-2, *Non-destructive testing — Characterization and verification of ultrasonic phased array systems — Part 2: Probes*

EN 16392-3, *Non-destructive testing — Characterization and verification of ultrasonic phased array systems — Part 3: Complete systems*

EN 16018, *Non-destructive testing — Terminology — Terms used in ultrasonic testing with phased arrays*

### 3 Terms and definitions

For the purposes of this document, the terms and definitions given in EN 1330-4 and EN 16018 and the following apply.

**3.1  
phased array set-up**  
probe arrangement defined by probe characteristics (e.g. frequency, probe element size, beam angle, wave mode), probe position, and the number of probes

**3.2  
phased array image**  
one- or two-dimensional display, constructed from the collected information of phased array operation

**3.3  
probe position  
PP**  
distance between the front of the wedge and the weld centreline

**3.4  
phased array indication**  
pattern or disturbance in the phased array image which may need further evaluation

**3.5  
skewed scan**  
scan performed with a skewed angle

NOTE The skewed angle can be achieved electronically or by means of probe orientation

**3.6  
scan increment**  
distance between successive data collection points in the direction of scanning (mechanically or electronically)

### 4 Testing levels

Quality requirements for welded joints are mainly associated with the material, welding process and service conditions. To accommodate all of these requirements, this International Standard specifies four testing levels (A, B, C, and D).

From testing level A to testing level C, an increasing probability of detection is achieved by an increasing testing coverage, e.g. number of incidences, combining techniques.

Testing level D may be agreed for special application using a written procedure which shall take into account the general requirements of this International Standard. This includes tests of metals other than ferritic steel, tests on partial penetration welds, tests with automated equipment, tests at object temperatures outside the range.

In general, the testing levels are related to quality levels (e.g. ISO 5817<sup>[2]</sup>). The appropriate testing level can be specified by standards for testing of welds (e.g. ISO 17635), product standards or other documents. When ISO 17635 is specified, the recommended testing levels are as given in Table 1.

**Table 1 — Recommended testing levels**

Testing level	Quality level in ISO 5817 <sup>[2]</sup>
A	C, D
B	B
C	by agreement
D	special application

Table 2 shows the minimum requirements and in all cases as described in 7.2 the set-up shall be verified with a reference block. In cases where scanning is from one face (excluding TOFD), half and full skip shall be used and stored; if scanning is performed from both faces, half skip is sufficient.

If the evaluation of the indications is based on amplitude only, the deviation from the normal to the weld shall not exceed 6°.

**Table 2 — Description of testing levels**

Mode	Testing levels			Example of sketches
	A	B	C	
	Reference block (see Annex A)			
	Block A	Block B	Block C	
Test set-up				
Fixed angles at fixed probe position to weld (line scans) <sup>a</sup>	Two sides	Not suitable as single technique	Two sides	
Fixed angles with raster scanning <sup>a</sup>	One side	One side	One side	
E-scan at fixed probe position (line scan) <sup>a</sup>	One side	Two sides with two angles <sup>c</sup>	Two sides	
S-scan at fixed probe position to weld (line scan) <sup>a</sup>	One side	Two sides or two probe positions	Two sides or two probe positions	
S-scan raster	Not recommended		One side	
TOFD generated with phased array <sup>a</sup>	Not recommended, TOFD testing in accordance with ISO 10863		One set-up	
Skewed scan <sup>b</sup>	If required by specification			

<sup>a</sup> For testing level C, at least two different test set-ups from this table shall be combined; at least one of them shall be S-scan or TOFD.

<sup>b</sup> If detection of transverse discontinuities is required by specification, a suitable additional test set-up shall be applied. Skewed probe or electronically skewed beam can be used.

<sup>c</sup> At least 10° difference.

## 5 Information required prior to testing

### 5.1 Items to be defined prior to procedure development

Information on the following items is required:

- a) purpose and extent of testing;
- b) testing levels;
- c) acceptance criteria;
- d) specification of reference blocks;
- e) manufacturing or operation stage at which the testing is to be carried out;
- f) weld details and information on the size of the heat-affected zone;
- g) requirements for access and surface conditions and temperature;
- h) personnel qualifications;
- i) reporting requirements.

### 5.2 Specific information required by the operator before testing

Before any testing of a welded joint can begin, the operator shall have access to all the information as specified in 5.1 together with the following additional information:

- a) written test procedure;
- b) type(s) of parent material and product form (i.e. cast, forged, rolled);
- c) joint preparation and dimensions;
- d) welding instruction or relevant information on the welding process;
- e) time of inspection relative to any post-weld heat treatment;
- f) result of any parent metal testing carried out prior to and/or after welding.

### 5.3 Written test procedure

For all testing levels a written test procedure is required.

A procedure shall be written and shall include the following information as a minimum:

- a) the purpose and extent of testing;
- b) testing techniques;
- c) testing levels;
- d) personnel qualification/training requirements;
- e) equipment requirements (including but not limited to frequency, sampling rate, pitch between elements, element size);
- f) reference and/or test blocks;
- g) the setting of equipment;
- h) available access and surface conditions;



- i) the testing of parent material;
- j) the evaluation of indications;
- k) acceptance levels and/or recording levels;
- l) reporting requirements;
- m) environmental and safety issues.

The procedure shall include a documented testing strategy or scan plan showing probe placement, movement, and component coverage that provides a standardized and repeatable methodology for weld testing. The scan plan shall also include ultrasonic beam angles used, beam directions with respect to the weld centreline, and volume examined for each weld.

## 6 Requirements for personnel and equipment

### 6.1 Personnel qualifications

Personnel performing testing in accordance with this International Standard shall be qualified to an appropriate level in accordance with EN 473, ISO 9712 or equivalent in the relevant industrial sector.

In addition to a general knowledge of ultrasonic weld inspection, the operators shall be familiar with and have practical experience in the use of phased arrays. Specific training and examination of personnel should be performed on representative pieces. These training and examination results should be documented. If this is not the case, specific training and examination should be performed with the finalized ultrasonic testing procedures and selected ultrasonic testing equipment on representative samples containing natural or artificial reflectors similar to those expected. These training and examination results should be documented.

### 6.2 Equipment

**6.2.1 General.** In selecting the system components (hardware and software) CEN/TR 15134<sup>[6]</sup> gives useful information.

**6.2.2 Ultrasonic equipment and display.** Ultrasonic equipment used for the phased array testing should be in accordance with the requirements of EN 16392-1, EN 16392-2, and EN 16392-3 when applicable.

The equipment shall be able to select an appropriate portion of the time base within which A-scans are digitized.

It is recommended that a sampling rate of the A-scan be used of at least six times the nominal probe frequency.

**6.2.3 Ultrasonic probes.** Both longitudinal and shear wave modes may be used.

Adaptation of probes to curved scanning surfaces shall comply with ISO 17640. When adapted probes are used, the influence on the sound beam shall be taken into account.

**6.2.4 Scanning mechanisms.** To achieve consistency of the images (collected data), guiding mechanisms and scan encoder(s) shall be used.

## 7 Preparation for testing

### 7.1 Volume to be inspected

The purpose of the testing shall be defined by specification. Based on this, the volume to be inspected shall be determined.

For tests at the manufacturing stage, the testing volume shall include the weld and parent material for at least 10 mm on each side of the weld (5 mm for laser welds and for electron beam welds), or the width of the heat-affected zone (based on the manufacturer's information), whichever is greater.

A scan plan should be provided. The scan plan should show the beam coverage, the weld thickness and the weld geometry.

Ensure that the sound beam(s) cover(s) the volume to be tested.

## **7.2 Verification of test set-up**

The capability of the test set-up shall be verified by the use of reference blocks.

## **7.3 Scan increment setting**

The scan increment setting along the weld is dependent upon the wall thickness to be examined. For thicknesses up to 10 mm, the scan increment shall be no more than 1 mm. For thicknesses between 10 mm and 150 mm, the scan increment shall be no more than 2 mm. Above 150 mm, a scan increment of 3 mm is recommended.

The scan increment setting perpendicular to the weld when applicable shall be chosen in order to ensure the coverage of the examination volume.

When TOFD is used, the scan increment shall be in accordance with ISO 10863.

## **7.4 Geometry considerations**

Care should be taken when examining welds of complex geometry, e.g. weld joining materials of unequal thickness, materials that are joined at an angle or nozzles. These tests should be planned carefully and require in-depth knowledge of sound propagation and shall always be carried out under testing level D.

For level D tests scan plan(s), representative reference block(s), and a performance demonstration are mandatory (see Annex A).

NOTE In some cases, the number of reference blocks can be reduced by use of simulation programs.

## **7.5 Preparation of scanning surfaces**

Scanning surfaces shall be clean in an area wide enough to permit the testing volume to be fully covered.

Scanning surfaces shall be even and free from foreign matter likely to interfere with probe coupling (e.g. rust, loose scale, weld spatter, notches, grooves). Waviness of the test surface shall not result in a gap between a probe and the test surface greater than 0,5 mm. These requirements shall be ensured by dressing the scanning surface, if necessary.

Scanning surfaces may be assumed to be satisfactory if the surface roughness,  $R_a$ , is not greater than 6,3  $\mu\text{m}$  for machined surfaces, or not greater than 12,5  $\mu\text{m}$  for shot-blasted surfaces.

When coating, paint, cladding etc. is present and is not to be removed, testing level D is applicable.

## **7.6 Temperature**

When not using special high temperature phased array probes and couplants, the surface temperature of the object under testing shall be in the range 0 °C to 50 °C.

For temperatures outside this range, the suitability of the equipment shall be verified.

## **7.7 Couplant**

In order to generate proper images, a couplant shall be used which provides a constant transmission of ultrasound between the probes and the material.

The couplant used for calibration shall be the same as that used in subsequent testing and post-calibrations.

## 8 Testing of base material

When the test is performed according to this International Standard, a lamination test shall be performed. This may be carried out as part of or independent of the test.

## 9 Range and sensitivity settings

### 9.1 Settings

#### 9.1.1 General

Setting of range and sensitivity shall be carried out prior to each test in accordance with this International Standard. Any change of the phased array set-up, e.g. probe position (PP) and steering parameters, requires a new setting.

Signal-to-noise ratio should be optimized with a minimum of 12 dB for the reference signals, when using A-scans, or with a minimum of 6 dB when using images.

#### 9.1.2 Pulse echo time window

If applicable, the time window used for pulse echo signals shall include the volume of interest and be described in the written test procedure.

Ensure that the combination of beams covers the area of interest.

#### 9.1.3 Pulse echo sensitivity settings

##### 9.1.3.1 General

After selection of the mode (fixed angle, E-scan, S-scan) the following shall be carried out:

- a) sensitivity shall be set for each beam generated (beam angle, focal point etc.) by the phased array probe;
- b) when a probe with wedge is used the sensitivity shall be set with the wedge in place.

##### 9.1.3.2 Focusing

Different modes of focusing can be applied with phased array probes, e.g. static and dynamic depth focusing (DDF).

When focusing is used, the sensitivity shall be set for each focused beam.

##### 9.1.3.3 Gain corrections

The use of angle-corrected gain (ACG) and time-corrected gain (TCG) enables the display of signals for all beam angles and all distances with the same amplitude.

##### 9.1.3.4 Sensitivity settings for different modes of phased array testing

For weld testing, different modes can be applied, e.g. fixed angles, E-scans, S-scans. After the previous steps, the reference sensitivity for each beam generated shall be set according to ISO 17640, including transfer correction if applicable.

### 9.1.4 TOFD settings

If TOFD testing is performed, all settings shall comply with the requirements specified in ISO 10863.

**9.2 Checking of the settings**

Check the settings at least every 4 h and after completion of the testing. If the single test takes more than 4 h, the settings shall be checked after completion of the test.

If a reference block was used for initial setting, the same reference block shall be used for checking. Alternatively, a smaller block with known transfer properties may be used.

If deviations from the initial settings, in accordance with 9.1, are found during these checks the corrections given in Table 3 shall be carried out.

**Table 3 — Sensitivity and range corrections**

<b>Sensitivity</b>	
Deviations ≤4 dB	No action required; data may be corrected by software
Deviations >4dB	The complete chain of measurement shall be checked. If no defective components are identified, settings shall be corrected and all tests carried out since the last valid check shall be repeated
NOTE 1 The required signal-to-noise ratio has to be achieved.	NOTE 2 The deviation 4 dB applies for pulse echo testing. For TOFD testing 6 dB deviation is allowed.
<b>Range</b>	
Deviations ≤0,5 mm or 2 % of depth-range, whichever is greater	No action required
Deviations >0,5 mm or 2 % of depth-range, whichever is greater	Settings shall be corrected and all tests carried out since the last valid check shall be repeated

**9.3 Reference blocks**

**9.3.1 General**

Depending on the testing level, reference blocks shall be used to determine the adequacy of the testing (e.g. coverage, sensitivity setting). Recommendations for reference blocks are shown in Annex A.

**9.3.2 Material**

The reference block shall be made of similar material to the test object (e.g. with regard to sound velocity, grain structure, and surface condition).

**9.3.3 Dimensions and shape**

The thickness of the reference blocks is recommended to be between 0,8 and 1,5 times the thickness of the test object with a maximum difference in thickness of 20 mm compared to the test object. The length and width of the reference block should be chosen such that all the artificial defects can be properly scanned. For testing of longitudinal welds in cylindrical test objects, curved reference blocks shall be used having diameters from 0,9 to 1,5 times the test object diameter. For test objects having a diameter ≥300 mm a flat reference block may be used.

**9.3.4 Reference reflectors**

For a thickness between 6 mm and 25 mm, at least three reflectors are required; for a thickness  $t > 25$  mm at least five reflectors are required. Typical reference reflectors are side-drilled holes, notches and flat-bottomed holes.

Details of the reference block according to the testing levels are given in Table 4 and Annex A.

Table 4 — Testing levels and reference blocks

Testing level	Reference block
A	see Figure A.1
B	see Figure A.2
C	see Figure A.3
D	as specified

## 10 Equipment checks

Check to verify that all relevant channels, probes, and cables of the ultrasonic phased array system are functional. This check shall be performed daily before and after testing. If any item of the system fails, corrective action shall be taken and the system shall be retested.

## 11 Procedure qualification

Procedure qualification is required for testing levels B, C, and D. The test procedure shall have been demonstrated to perform acceptably on reference block(s). Examples of reference blocks are described in Annex A.

A satisfactory procedure qualification shall take place prior to the first inspection.

A satisfactory procedure qualification includes:

- a) detection of all required reflectors;
- b) sizing capability as required by specification;
- c) proof of coverage in depth and width.

## 12 Weld testing

Before initial testing, the coverage shall be verified with the scan plan and demonstrated on a suitable reference block.

Acceptable deviations of probe position relative to the weld centreline shall be documented in the test procedure, and shall be covered in the scan plan and shown on reference block.

Some indications detected during the initial scanning may require additional evaluation, offset-scans, scans perpendicular to the discontinuity, complementary phased array-set-ups, etc.

Scanning speed shall be chosen such that satisfactory images are generated (see 14.1). The scanning speed shall be selected dependent on factors such as number of delay laws, scan resolution, signal averaging, pulse-repetition frequency, data acquisition frequency, and volume to be inspected. Missing scan lines indicate that too high a scanning speed has been used. A maximum of 5 % of the total number of lines collected in one single scan may be missed but no adjacent lines shall be missed.

If the length of a weld is scanned in more than one section, an overlap of at least 20 mm between the adjacent scans is required. When scanning circumferential welds, the same overlap is required for the end of the last scan with the start of the first scan.

If applicable, a control function for the coupling efficiency is recommended.

## 13 Data storage

The ultrasonic testing shall be performed using a device employing computer-based data acquisition. All A-scan data covering the examination area shall be stored and all data sets with set-up parameters shall be included in the data record.

All data shall be stored for a period as specified.

## 14 Interpretation and analysis of phased array data

### 14.1 General

Interpretation and analysis of phased array data are typically performed as follows:

- a) assess the quality of the phased array data;
- b) identify relevant indications;
- c) classify relevant indications as specified;
- d) determine location and size as specified;
- e) evaluate against acceptance criteria.

### 14.2 Assessing the quality of the phased array data

A phased array test has to be carried out such that satisfactory images are generated which can be evaluated with confidence. Satisfactory images are defined by appropriate:

- a) coupling;
- b) time-base setting;
- c) sensitivity setting;
- d) signal-to-noise ratio;
- e) saturation indicator;
- f) data acquisition.

Assessing the quality of phased array images requires skilled and experienced operators (see 6.1). The operator has to decide whether non-satisfactory images require new data acquisition (rescan).

### 14.3 Identification of relevant indications

The phased array technique images both discontinuities in the weld and geometric features of the test object.

In order to identify indications of geometric features, detailed knowledge of the test object is necessary.

To decide whether an indication is relevant (caused by a discontinuity), patterns or disturbances have to be evaluated considering shape and signal amplitude relative to general noise level.

### 14.4 Classification of relevant indications

Amplitude, location and pattern of relevant indications may contain information on the type of discontinuity.

Relevant indications shall be classified as specified.

## 14.5 Determination of location and length of an indication

### 14.5.1 Location

The location of an indication parallel to the weld axis, perpendicular to the weld axis and in the through-wall direction shall be determined from the collected data.

### 14.5.2 Length

The length of an indication is defined as the dimension along the weld. The method of determining length shall be in accordance with the acceptance level applied.

## 14.6 Indication assessment

### 14.6.1 General

This assessment can be based on amplitude, equivalent reflector size or on height and length according to specification.

### 14.6.2 Based on amplitude

The maximum amplitude of each indication shall be evaluated according to the specified acceptance level. The amplitude drop can be used to determine the length of an indication.

### 14.6.3 Based on height

The height of an indication is the extent in the through-wall direction. For indications displaying varying height along their length, the height shall be determined at the scan position of maximum extent.

If a more accurate height determination is required, reconstruction algorithms, e.g. synthetic aperture focusing technique (SAFT), may be used.

## 14.7 Evaluation against acceptance criteria

After classification of all relevant indications, determination of their location and length, and assessment, the indications shall be evaluated against specified acceptance criteria.

The indications can then be categorized as “acceptable” or “not acceptable”.

## 15 Test report

The test report shall include at least the following information:

- a) a reference to this International Standard (ISO 13588:2012);
- b) information relating to the object under test:
  - 1) identification of the object under test,
  - 2) dimensions including wall thickness,
  - 3) material type and product form,
  - 4) geometrical configuration,
  - 5) location of welded joint(s) examined,
  - 6) reference to welding process and heat treatment,
  - 7) surface condition and temperature,

- 8) stage of manufacture;
- c) information relating to equipment:
- 1) manufacturer and type of phased array instrument including scanning mechanisms with identification numbers if required,
  - 2) manufacturer, type, frequency of phased array probes including number and size of elements, material and angle(s) of wedges with identification numbers if required,
  - 3) details of reference block(s) with identification numbers if required,
  - 4) type of couplant used;
- d) Information relating to test technology:
- 1) testing level and reference to a written test procedure,
  - 2) purpose and extent of test,
  - 3) details of datum and coordinate systems,
  - 4) method and values used for range and sensitivity settings,
  - 5) details of signal processing and scan increment setting,
  - 6) scan plan,
  - 7) access limitations and deviations from this International Standard, if any;
- e) Information relating to phased array setting:
- 1) increment (E-scans) or angular increment (S-scans),
  - 2) element pitch and gap dimensions,
  - 3) focus (calibration should be the same as scanning),
  - 4) virtual aperture size, i.e. number of elements and element width,
  - 5) element numbers used for focal laws,
  - 6) documentation on permitted wedge angular range from manufacturer,
  - 7) documented calibration, TCG and angle gain compensation;
- f) Information relating to test results:
- 1) reference to the phased array raw data file(s),
  - 2) phased array images of at least those locations where relevant indications have been detected on hard copy, all images or data available in soft format,
  - 3) acceptance criteria applied,
  - 4) tabulated data recording the classification, location and size of relevant indications and results of evaluation,
  - 5) reference points and details of the coordinate system,
  - 6) date of test,
  - 7) names, signatures and certification of personnel.



## Annex A (informative)

### Typical reference blocks and reference reflectors

#### A.1 Reference reflectors

For a thickness between 6 mm and 25 mm, at least three reference reflectors are recommended. The reflectors may be machined in one or more blocks.

For a thickness >25 mm, at least five reference reflectors are recommended. The reflectors may be machined in one or more blocks.

The tolerances for all the dimensions of the reference reflectors are as follows:

- diameter:  $\pm 0,2$  mm
- length:  $\pm 2$  mm
- angle:  $\pm 2^\circ$
- Tables A.1, A.2, and A.3 describe the reference reflectors for different wall thicknesses. If TOFD is used, then refer to ISO 10863 for details of reference notches.

**Table A.1 — Length and depth of notches in the reference block**

Dimensions in millimetres

Thickness <i>t</i>	Length <i>l</i>	Height <i>h</i>	Width <i>b</i>
$6 < t \leq 40$	<i>t</i>	$1 \pm 0,2$	$0,2 \pm 0,05$
$40 < t \leq 60$	$40 \pm 2$	$2 \pm 0,2$	$0,2 \pm 0,05$
$60 < t \leq 100$	$50 \pm 2$	$2 \pm 0,2$	$0,2 \pm 0,05$
$t > 100$	$60 \pm 2$	$3 \pm 0,2$	$0,2 \pm 0,05$

**Table A.2 — Diameter  $D_d$  of side-drilled holes**

Dimensions in millimetres

Thickness <i>t</i>	Diameter $D_d$
$6 < t \leq 25$	$2,5 \pm 0,2$
$25 < t \leq 50$	$3,0 \pm 0,2$
$50 < t \leq 100$	$4,5 \pm 0,2$
$t > 100$	$6,0 \pm 0,2$

NOTE If near-side surface holes are required they shall have a diameter of 2 mm; see Figure A.2.

Table A.3 — Length of side-drilled holes and surface notches for thickness  $t > 25$  mm

Depth	Three holes in the same block Minimum length mm	Three separate blocks, one hole per block Minimum length mm	Three notches in the same block Minimum length mm	Three separate blocks, one notch per block Minimum length mm
$1/4t$	$l_0 = 45$	45	40	40
$1/2t$	$l_0 + 15$	45	40	40
$3/4t$	$l_0 + 30$	45	40	40

## A.2 Typical reference blocks

### A.2.1 Testing level A (Figure A.1)

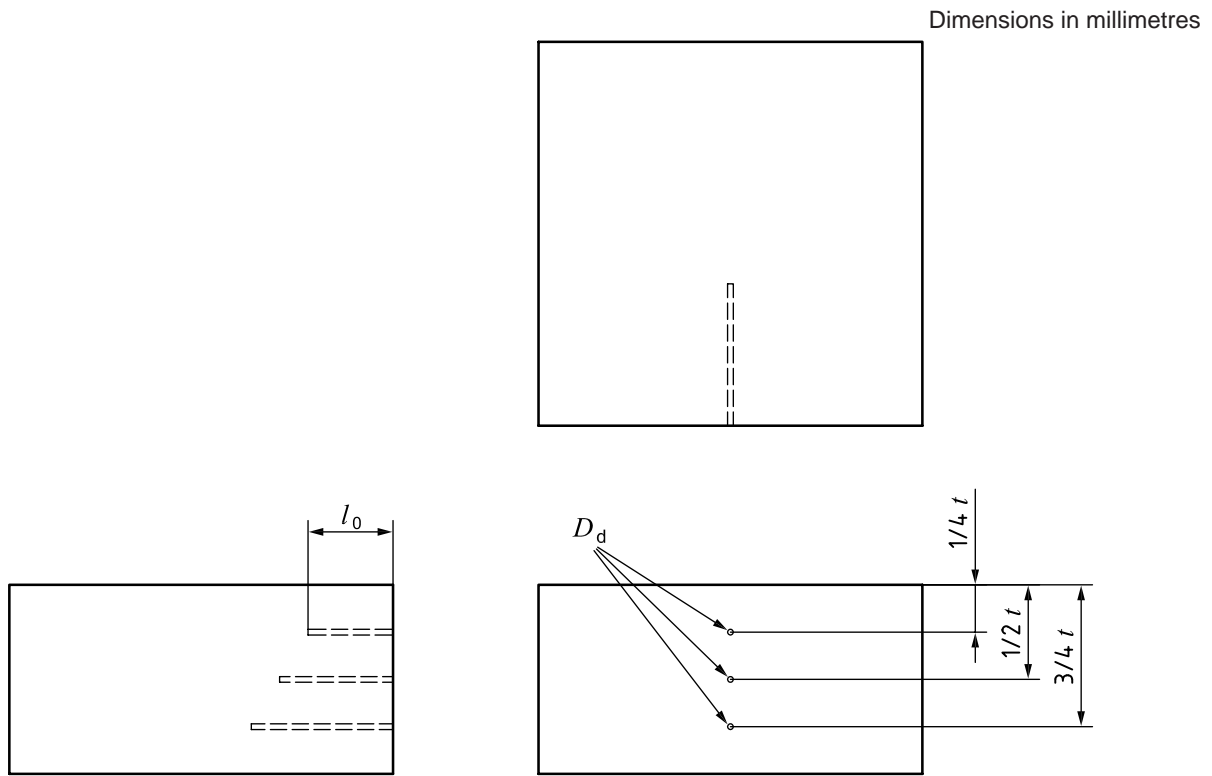

**Key**

- $D_d$  diameter of side-drilled hole
- $l_0$  length of side-drilled hole
- $t$  thickness of block

Figure A.1 — Recommended reference block for testing level A

**A.2.2 Testing level B (Figure A.2)**

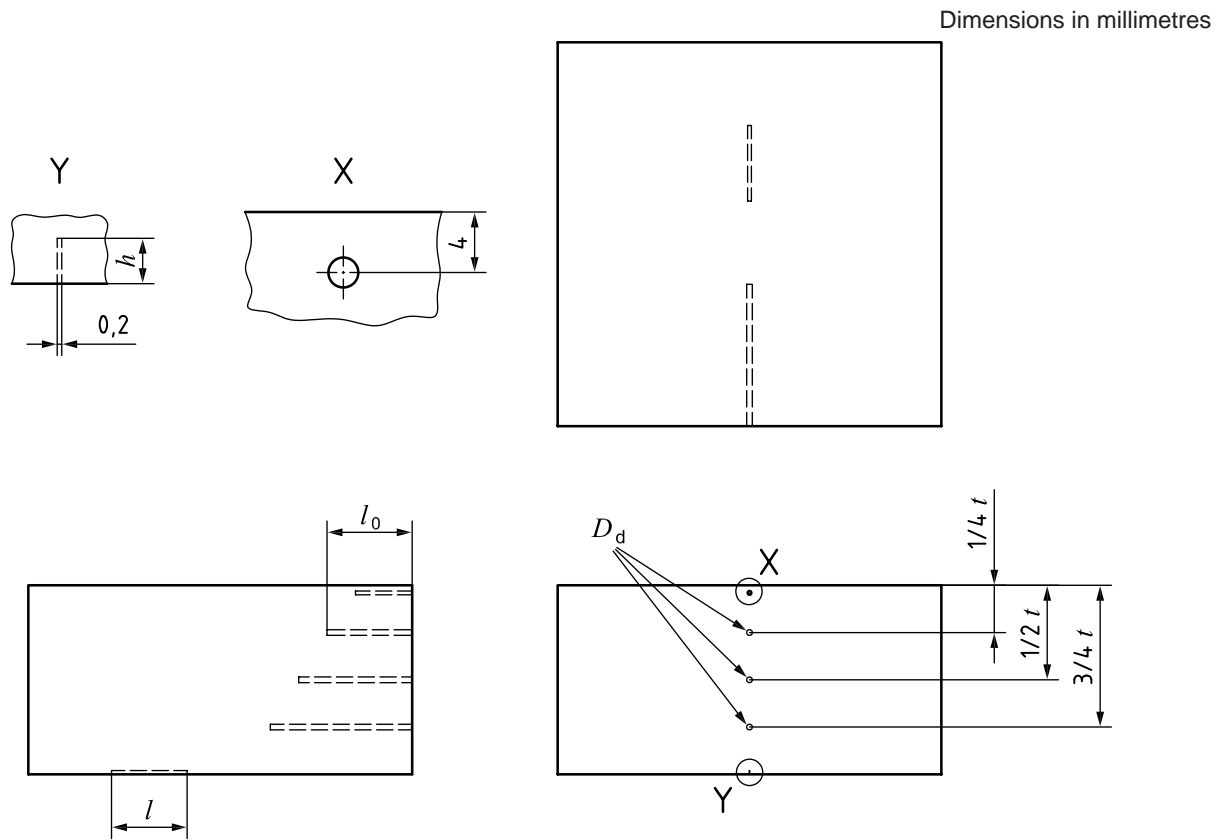

**Key**

- $D_d$  diameter of side-drilled hole
- $h$  depth of notch at the bottom
- $l$  length of notch at the bottom
- $l_0$  length of side-drilled hole
- $t$  thickness of block

Detail X shows a side-drilled hole located at 4 mm below the surface, with a diameter of 2 mm and a minimum length of 30 mm. Alternatively a surface notch can be used with the same dimensions as described in Table A.1.

**Figure A.2 — Recommended reference block for testing level B**

A.2.3 Testing level C (Figure A.3)

Dimensions in millimetres

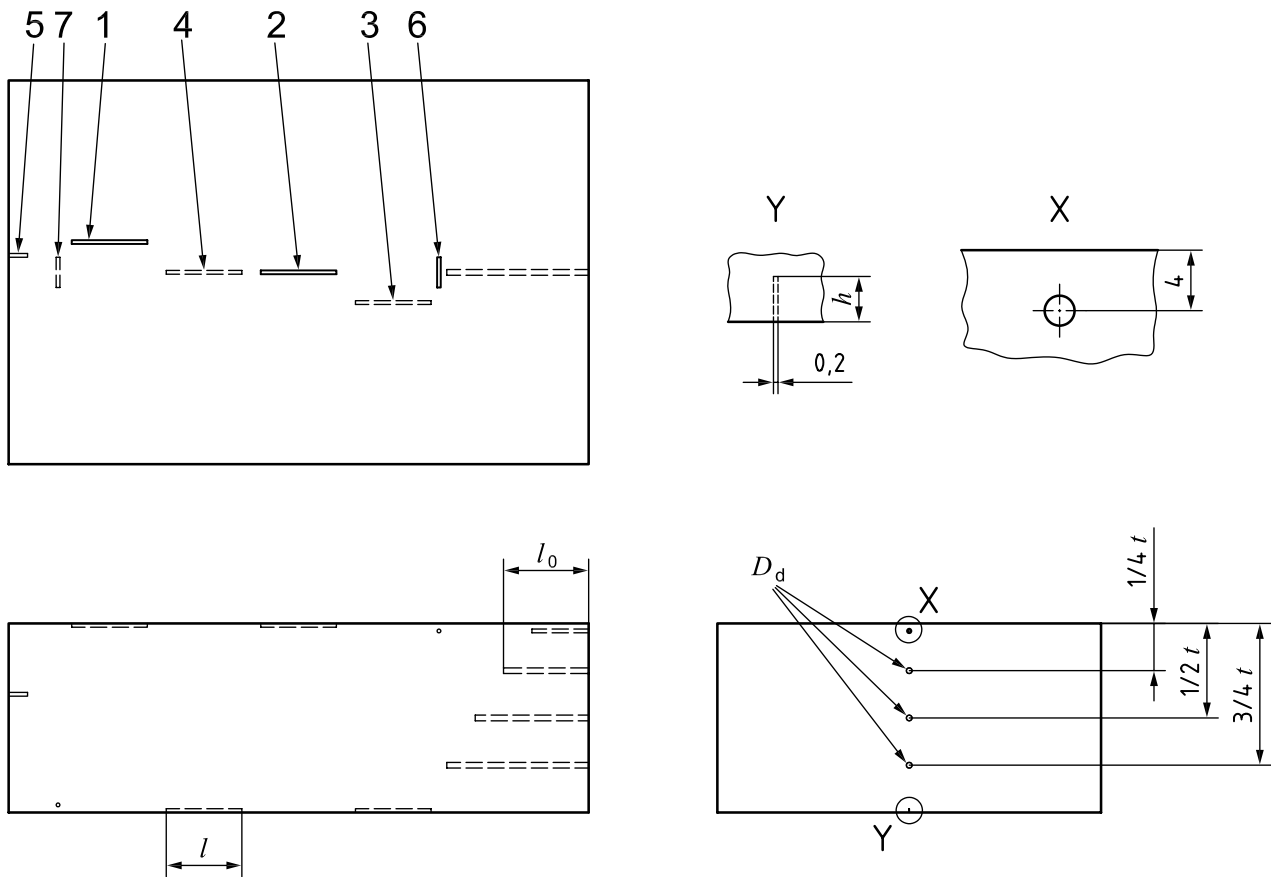

**Key**

$D_d$	diameter of side-drilled hole	1, 2	near-side surface notches
$h$	depth of notch	3, 4	far-side surface notches
$l$	length of notches	5	notch on imaginary weld bevel
$l_0$	length of side-drilled hole	If required by specification:	
$t$	thickness of block	6	near-side surface transverse notch
		7	far-side surface transverse notch

Detail X shows a side-drilled hole located at 4 mm below the surface, of diameter 2 mm and minimum length 30 mm. Alternatively a surface notch can be used with the same dimensions as described in Table A.1.

The notches 2 and 4 are positioned at the imaginary weld centreline. The notches 1 and 3 are positioned at the edges of the volume to be tested. Notch 5 is positioned on the imaginary weld bevel with an orientation of  $\pm 5^\circ$  to the weld bevel. The dimensions and the location of notch 5 shall be as specified.

There should be a volume in the reference block which is kept free from artificial reflectors. The extent of this volume should exceed the sound beam width. This volume should be symmetrical about the weld centreline.

**Figure A.3 — Recommended reference block for testing level C**

A.2.4 Testing level D

For testing level D, special blocks shall be made with the same configuration, base material properties, weld material properties, weld process and additional to the test blocks described for testing levels B and C; additional reflectors shall be added.

## Bibliography

- [1] ISO 3183, *Petroleum and natural gas industries — Steel pipe for pipeline transportation systems*
- [2] ISO 5817, *Welding — Fusion-welded joints in steel, nickel, titanium and their alloys (beam welding excluded) — Quality levels for imperfections*
- [3] ISO 10893-8, *Non-destructive testing of steel tubes — Part 8: Automated ultrasonic testing of seamless and welded steel tubes for the detection of laminar imperfections*
- [4] ISO 10893-11, *Non-destructive testing of steel tubes — Part 11: Automated ultrasonic testing of the weld seam of welded steel tubes for the detection of longitudinal and/or transverse imperfections*
- [5] EN 583-1, *Non-destructive testing — Ultrasonic examination — Part 1: General principles*
- [6] CEN/TR 15134, *Non-destructive testing — Automated ultrasonic examination — Selection and application of systems*

