**Centrifugally cast steel and alloy
products —**

**Part 1:
General testing and tolerances**

*Produits en acier et alliages moulés par centrifugation —
Partie 1: Conditions générales d'essais et tolérances*



Reference number
ISO 13583-1:2000(E)

© ISO 2000

PDF disclaimer

This PDF file may contain embedded typefaces. In accordance with Adobe's licensing policy, this file may be printed or viewed but shall not be edited unless the typefaces which are embedded are licensed to and installed on the computer performing the editing. In downloading this file, parties accept therein the responsibility of not infringing Adobe's licensing policy. The ISO Central Secretariat accepts no liability in this area.

Adobe is a trademark of Adobe Systems Incorporated.

Details of the software products used to create this PDF file can be found in the General Info relative to the file; the PDF-creation parameters were optimized for printing. Every care has been taken to ensure that the file is suitable for use by ISO member bodies. In the unlikely event that a problem relating to it is found, please inform the Central Secretariat at the address given below.

© ISO 2000

All rights reserved. Unless otherwise specified, no part of this publication may be reproduced or utilized in any form or by any means, electronic or mechanical, including photocopying and microfilm, without permission in writing from either ISO at the address below or ISO's member body in the country of the requester.

ISO copyright office
Case postale 56 • CH-1211 Geneva 20
Tel. + 41 22 749 01 11
Fax + 41 22 749 09 47
E-mail copyright@iso.ch
Web www.iso.ch

Printed in Switzerland

Foreword

ISO (the International Organization for Standardization) is a worldwide federation of national standards bodies (ISO member bodies). The work of preparing International Standards is normally carried out through ISO technical committees. Each member body interested in a subject for which a technical committee has been established has the right to be represented on that committee. International organizations, governmental and non-governmental, in liaison with ISO, also take part in the work. ISO collaborates closely with the International Electrotechnical Commission (IEC) on all matters of electrotechnical standardization.

International Standards are drafted in accordance with the rules given in the ISO/IEC Directives, Part 3.

Draft International Standards adopted by the technical committees are circulated to the member bodies for voting. Publication as an International Standard requires approval by at least 75 % of the member bodies casting a vote.

Attention is drawn to the possibility that some of the elements of this part of ISO 13583 may be the subject of patent rights. ISO shall not be held responsible for identifying any or all such patent rights.

International Standard ISO 13583-1 was prepared by Technical Committee ISO/TC 17, *Steel*, Subcommittee SC 11, *Steel castings*.

ISO 13583 consists of the following parts, under the general title *Centrifugally cast steel and alloy products*:

Part 1: General testing and tolerances

Part 2: Materials

Centrifugally cast steel and alloy products —

Part 1: General testing and tolerances

1 Scope

This part of ISO 13583 specifies the requirements for horizontal and vertical centrifugally cast products to be used in the following applications:

- a) heat resisting;
- b) corrosion resisting;
- c) general engineering.

2 Normative references

The following normative documents contain provisions which, through reference in this text, constitute provisions of this part of ISO 13583. For dated references, subsequent amendments to, or revisions of, any of these publications do not apply. However, parties to agreements based on this part of ISO 13583 are encouraged to investigate the possibility of applying the most recent editions of the normative documents indicated below. For undated references, the latest edition of the normative document referred to applies. Members of ISO and IEC maintain registers of currently valid International Standards.

ISO 783:1999, *Metallic materials — Tensile testing at elevated temperature.*

ISO 3651-1:1998, *Determination of resistance to intergranular corrosion of stainless steels — Part 1: Austenitic and ferritic-austenitic (duplex) stainless steels — Corrosion test in nitric acid medium by measurement of loss in mass (Huey test).*

ISO 3651-2:1998, *Determination of resistance to intergranular corrosion of stainless steels — Part 2: Ferritic, austenitic and ferritic-austenitic (duplex) stainless steels — Corrosion test in media containing sulfuric acid.*

ISO 4986:1992, *Steel castings — Magnetic particle inspection.*

ISO 4987:1992, *Steel castings — Penetrant inspection.*

ISO 4990:1986, *Steel castings — General technical delivery requirements.*

ISO 4993:1987, *Steel castings — Radiographic inspection.*

ISO 13520:—¹⁾, *Steel castings — Estimation of ferrite content in austenitic stainless steel castings.*

1) To be published.

3 Term and definition

For the purposes of this part of ISO 13583 the following term and definition apply.

3.1 minimum sound wall thickness MSW

thickness which remains when all the porosity and roughness associated with the internal and external cast surfaces have been removed by machining

[See Figures 1 and 2]

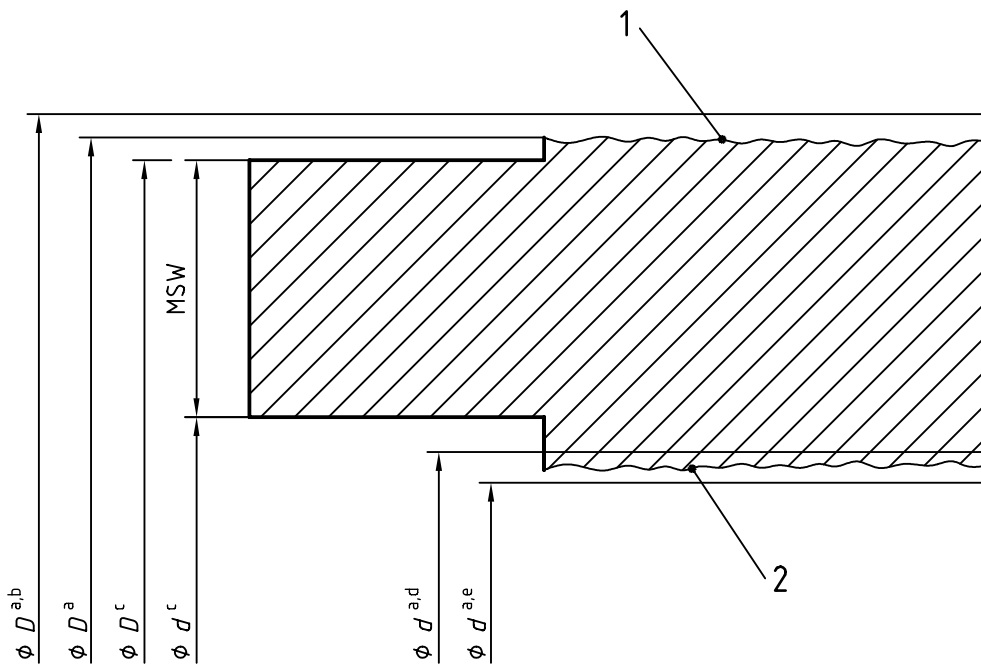

Key

- 1 Outside roughness
- 2 Inside porosity

D is the outside diameter
 d is the inside diameter

- a As-cast
- b + tolerance
- c Machined
- d + porosity
- e - tolerance

Figure 1 — Horizontal centrifugally cast tube

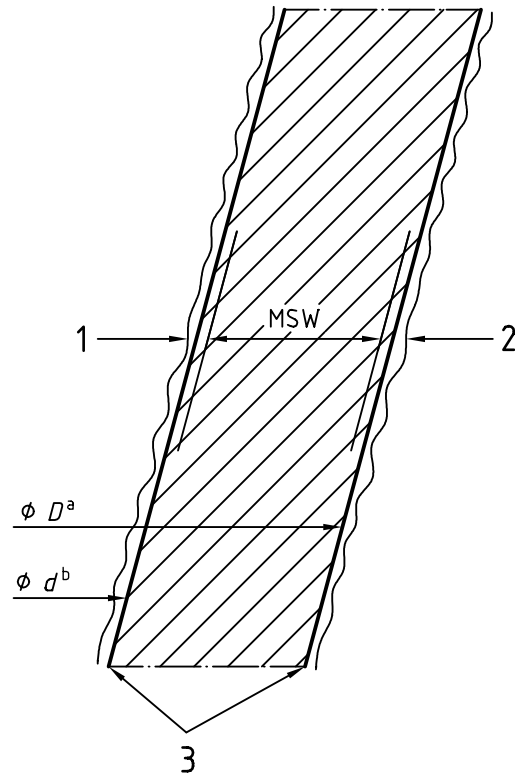
**Key**

- 1 Inside porosity
 - 2 Outside roughness
 - 3 Unmachined surfaces with MSW and additions resulting from tolerances on diameters
- a Machined + tolerance
 - b Machined – tolerance

Figure 2 — Vertical centrifugally cast tube

4 Materials

Materials shall be specified by the purchaser.

5 Supply

The product shall comply with the requirements of ISO 4990.

6 Mechanical Tests

6.1 Test pieces for mechanical tests shall be taken either from the centrifugally cast product or from separately cast test samples from the same melt as the casting and heat treated under the same conditions as the casting they represent.

Separately cast test samples are acceptable only if agreed between purchaser and manufacturer.

6.2 Upon agreement the tensile test at room temperature may be substituted by an elevated temperature tensile test, a stress to rupture test or a creep test, (see 12.3).

7 Surface finish requirements

The surface finish shall be agreed between purchaser and manufacturer.

8 Minimum sound wall (MSW) thickness and soundness

8.1 The purchaser may specify an MSW which may be measured in accordance with either 8.1.1 or 8.1.2, the method and criteria to be agreed between the purchaser and manufacturer at the time of the enquiry and order.

NOTE In the case of cast products supplied with an as-cast internal surface and having a specified MSW thickness, in order to compensate for unsoundness which may be associated with the cast internal surface, it is necessary to add an internal unsoundness allowance. The allowance that will be necessary in any specific cast will vary according to the total as-cast thickness of the cast product and the soundness requirements. In addition, an allowance may be required to accommodate any minor imperfections associated with the as-cast external surface.

8.1.1 A length of the cast product (100 mm minimum length) machined on the inside and outside diameter surfaces to produce a product having at least the specified MSW and dimensions in accordance with the customer's drawing.

8.1.2 The machined profile end (weld preparation) of the production product.

8.2 Dye penetrant inspection shall be carried out according to ISO 4987 after machining (see 10.2 and 10.3) and prior to MSW measurement.

8.3 The MSW thickness shall be measured at 90° intervals. All measurements shall be within the MSW tolerance.

9 Dimensional tolerances

9.1 General

The purchaser shall state clearly on the order the tolerances to be achieved, otherwise the following tolerances shall be used.

9.2 Length

The minimum length of the tube shall be agreed upon between the purchaser and manufacturer. In the case where two or more tubes are welded together, if the minimum length is not stated in the enquiry or order it shall be not less than 1,3 metres.

The tolerance on length shall be governed by the diameter of the product as shown in Table 1.

Table 1 — Tolerance on length

Diameter mm	Tolerance mm
≤ 150	+4 0
> 150	+5 0

9.3 Straightness

The deviation from straightness on the full length of tube shall be agreed upon between the purchaser and manufacturer. If no agreement is made, the deviation from straightness shall be at the discretion of the manufacturer.

The cast product may be mechanically straightened at room temperature.

All straightening shall be carried out prior to surface inspection.

9.4 Outside and inside diameters

9.4.1 The tolerance on the outside diameter of the as-cast product shall be in accordance with Table 2.

Table 2 — Tolerance on outside diameter, D

Diameter of product mm	Tolerance mm
≤ 150	$\begin{matrix} +2 \\ 0 \end{matrix}$
> 150 but ≤ 300	$\begin{matrix} +2,5 \\ 0 \end{matrix}$
> 300 but ≤ 500	$\begin{matrix} +4 \\ 0 \end{matrix}$
> 500 but ≤ 750	$\begin{matrix} +5 \\ 0 \end{matrix}$
> 750 but $\leq 1\ 000$	$\begin{matrix} +6 \\ 0 \end{matrix}$
$> 1\ 000$	$\begin{matrix} +8 \\ 0 \end{matrix}$

9.4.2 The tolerances on the machined surfaces shall be stated on the enquiry and order. If tolerances are not given, the following tolerances shall be used:

— tolerance on outside diameter $\begin{matrix} +1,5\text{ mm} \\ 0\text{ mm} \end{matrix}$

— tolerance on inside diameter $\begin{matrix} 0\text{ mm} \\ -1,5\text{ mm} \end{matrix}$

© ISO 2000. All rights reserved.

9.4.3 The tolerance on inside diameter, d , of the as-cast product shall be dependent upon the wall thickness of the product as shown in Table 3.

Table 3 — Tolerance on inside diameter, d

d mm	Wall thickness mm	Tolerance mm
≤ 30	—	$\begin{matrix} 0 \\ -3 \end{matrix}$
> 30 but ≤ 300	≤ 25	$\begin{matrix} 0 \\ -3 \end{matrix}$
	> 25 but ≤ 50	$\begin{matrix} 0 \\ -4 \end{matrix}$
	> 50 but ≤ 100	$\begin{matrix} 0 \\ -5 \end{matrix}$
> 300 but ≤ 900	≤ 50	$\begin{matrix} 0 \\ -4 \end{matrix}$
	> 50 but ≤ 80	$\begin{matrix} 0 \\ -5 \end{matrix}$
	> 80 but ≤ 100	$\begin{matrix} 0 \\ -6 \end{matrix}$

For products with an inside diameter greater than 900 mm and a wall thickness greater than 100 mm, the tolerance shall be by agreement between purchaser and manufacturer.

10 Inspection procedures and standards of acceptance

10.1 As-cast outside diameter surfaces shall be visually examined.

10.1.1 Any linear indication shall be unacceptable.

10.1.2 Non-linear indications whose depth violates the minimum sound wall thickness shall be unacceptable.

10.1.3 Grinding and dye penetrant examination, in accordance with ISO 4987, may be used to verify the type, presence and depth of the indications.

10.2 Unless otherwise stated on the enquiry and order, the dye penetrant inspection of machined end weld bevels shall have a minimum acceptance level of severity level 01 in accordance with ISO 4987:1992. In the event of failure to meet the above requirement the manufacturer may reduce the length of the tube.

The tube shall then be re-inspected to the above acceptance level.

10.3 Unless otherwise stated on the enquiry or order, the dye penetrant inspection of machined internal and external surfaces shall have a minimum acceptance level of severity level 4 in accordance with ISO 4987:1992.

When dye penetrant inspection of bore surfaces is required, the method and areas to be examined shall be agreed upon by the manufacturer and purchaser.

11 Production welding

Finishing welding shall not be carried out unless agreed upon by purchaser and manufacturer.

12 Supplementary requirements

12.1 General

These may be specified by the purchaser and agreed at the time of the enquiry and order.

12.2 Pressure test

This shall be carried out in accordance with ISO 4990.

12.3 Elevated temperature test

12.3.1 Tensile test at elevated temperature shall be carried out in accordance with ISO 783.

12.3.2 The test conditions for stress to rupture tests and creep tests shall be agreed upon by the purchaser and manufacturer.

12.4 Acid etch ring test

A ring may be taken for macro etching from the end of the product to ascertain the proportion of columnar and equiaxed structure.

The test conditions shall be agreed upon by purchaser and manufacturer.

12.5 Magnetic particle test

This shall be carried out on magnetic alloys only, and in accordance with ISO 4986.

12.6 Ferrite determination

This shall be carried out on austenitic and austenitic ferritic steels and shall be in accordance with ISO 13520.

12.7 Corrosion testing

12.7.1 Intergranular corrosion shall be tested for in accordance with ISO 3651-1 and ISO 3651-2.

12.7.2 Pitting corrosion testing shall be to a method agreed upon by the purchaser and the manufacturer.

12.7.3 Crevice corrosion testing shall be to a method agreed upon by the purchaser and the manufacturer.

12.8 Eddy current testing

Test conditions, method and criteria shall be agreed upon by the purchaser and the manufacturer.

12.9 Radiography

This shall be carried out in accordance with ISO 4993.

12.10 Ultrasonic testing

Test conditions, method and criteria shall be agreed upon by the purchaser and the manufacturer.

ICS 77.140.80

Price based on 7 pages

© ISO 2000 – All rights reserved