**Industrial furnaces and associated
processing equipment — Safety —**

Part 3:
**Generation and use of protective and
reactive atmosphere gases**

Fours industriels et équipements associés — Sécurité —

*Partie 3: Génération et utilisation des gaz d'atmosphère protectrice et
réactive*



COPYRIGHT PROTECTED DOCUMENT

© ISO 2016, Published in Switzerland

All rights reserved. Unless otherwise specified, no part of this publication may be reproduced or utilized otherwise in any form or by any means, electronic or mechanical, including photocopying, or posting on the internet or an intranet, without prior written permission. Permission can be requested from either ISO at the address below or ISO's member body in the country of the requester.

ISO copyright office
Ch. de Blandonnet 8 • CP 401
CH-1214 Vernier, Geneva, Switzerland
Tel. +41 22 749 01 11
Fax +41 22 749 09 47
copyright@iso.org
www.iso.org

Contents

Page

| | |
|--|-----------|
| Foreword | v |
| Introduction | vi |
| 1 Scope | 1 |
| 2 Normative references | 2 |
| 3 Terms and definitions | 3 |
| 4 Safety requirements and measures | 5 |
| 4.1 General | 5 |
| 4.2 Pipework | 5 |
| 4.2.1 General | 5 |
| 4.2.2 Connections | 6 |
| 4.2.3 Unconnected pipework | 6 |
| 4.2.4 Galvanic cells | 6 |
| 4.2.5 Flexible tubing and couplings | 6 |
| 4.2.6 Marking of pipework | 7 |
| 4.2.7 Soundness/Tightness | 7 |
| 4.2.8 Condensate drains | 7 |
| 4.2.9 Purge points | 7 |
| 4.2.10 Blow-off and breather pipes or conduits | 8 |
| 4.2.11 Pressure relief devices and flame arrestors on pipework | 8 |
| 4.2.12 Pressure oscillations | 8 |
| 4.2.13 Combustible gas by-pass | 8 |
| 4.2.14 Isolation of required safety devices | 8 |
| 4.2.15 Vents | 8 |
| 4.3 Required safety devices | 9 |
| 4.3.1 Atmosphere gas control equipment | 9 |
| 4.3.2 Other safety devices | 12 |
| 4.4 Requirements for the use of atmosphere gases | 12 |
| 4.4.1 Prevention of potential ignitable atmospheres | 12 |
| 4.4.2 Monitoring of TPE doors movements | 14 |
| 4.4.3 Supervision of the means of ignition at the point of combustible atmosphere gas discharge | 14 |
| 4.4.4 Emergency safety purge | 14 |
| 4.5 Change of atmosphere | 15 |
| 4.5.1 General | 15 |
| 4.5.2 Purge with purge gas | 15 |
| 4.5.3 Purge with self-ignition | 16 |
| 4.5.4 Change of atmosphere by burning | 16 |
| 4.5.5 Purge by evacuation | 17 |
| 4.6 Interfaces to exhaust systems for combustible or toxic atmosphere gases | 17 |
| 4.6.1 Exhaust of burned gases | 17 |
| 4.6.2 Gathering of gases without burning and a closed system | 18 |
| 5 Additional requirements for the generation of atmosphere gases | 18 |
| 5.1 General | 18 |
| 5.2 Gas and process liquid supplies | 18 |
| 5.2.1 Air supplies | 18 |
| 5.2.2 Reaction mixture supplies | 19 |
| 5.2.3 Generated atmosphere gas distribution | 19 |
| 5.3 Flame detection | 19 |
| 5.4 Burners generating exothermic gases | 19 |
| 5.5 Special requirements for different types of generator | 19 |
| 5.5.1 Requirements for endothermic generators | 19 |
| 5.5.2 Requirements for exothermic generators | 20 |

| | | |
|---------------------|--|-----------|
| 5.6 | Post-treatment of generated atmosphere gases | 20 |
| 6 | Verification of the safety requirements and/or measures | 21 |
| 7 | Information for use | 24 |
| 7.1 | General | 24 |
| 7.2 | Marking | 24 |
| 7.3 | Instruction handbook | 24 |
| 7.3.1 | General | 24 |
| 7.3.2 | Description of equipment | 25 |
| 7.3.3 | Inspection procedures | 25 |
| 7.3.4 | Commissioning, start-up and operating procedures | 25 |
| 7.3.5 | Shutdown procedures | 26 |
| 7.3.6 | Maintenance procedures | 27 |
| 7.3.7 | Documentation | 27 |
| Annex A | (informative) List of significant hazards | 28 |
| Annex B | (informative) Typical protective and reactive atmosphere gases | 30 |
| Annex C | (normative) Allowed maximum pressure | 32 |
| Annex D | (informative) Principle procedures for the change of atmosphere | 37 |
| Annex E | (informative) Examples for the determination of safety integrity level SIL and performance level PL using the risk graph method | 38 |
| Annex F | (informative) Basic configuration of piping system of TPE using protective or reactive atmosphere gases | 49 |
| Annex G | (normative) Requirements specific to Japan | 51 |
| Annex H | (normative) Requirements specific to the U.S.A. | 53 |
| Annex I | (normative) Requirements specific to European countries | 55 |
| Annex J | (informative) Overview of the terms defined in ISO 13574 (Vocabulary) | 58 |
| Bibliography | | 66 |

Foreword

ISO (the International Organization for Standardization) is a worldwide federation of national standards bodies (ISO member bodies). The work of preparing International Standards is normally carried out through ISO technical committees. Each member body interested in a subject for which a technical committee has been established has the right to be represented on that committee. International organizations, governmental and non-governmental, in liaison with ISO, also take part in the work. ISO collaborates closely with the International Electrotechnical Commission (IEC) on all matters of electrotechnical standardization.

The procedures used to develop this document and those intended for its further maintenance are described in the ISO/IEC Directives, Part 1. In particular the different approval criteria needed for the different types of ISO documents should be noted. This document was drafted in accordance with the editorial rules of the ISO/IEC Directives, Part 2 (see www.iso.org/directives).

Attention is drawn to the possibility that some of the elements of this document may be the subject of patent rights. ISO shall not be held responsible for identifying any or all such patent rights. Details of any patent rights identified during the development of the document will be in the Introduction and/or on the ISO list of patent declarations received (see www.iso.org/patents).

Any trade name used in this document is information given for the convenience of users and does not constitute an endorsement.

For an explanation on the meaning of ISO specific terms and expressions related to conformity assessment, as well as information about ISO's adherence to the World Trade Organization (WTO) principles in the Technical Barriers to Trade (TBT) see the following URL: www.iso.org/iso/foreword.html.

The committee responsible for this document is ISO/TC 244, *Industrial furnaces and associated processing equipment*.

ISO 13577 consists of the following parts, under the general title *Industrial furnaces and associated processing equipment — Safety*:

- *Part 1: General requirements*
- *Part 2: Combustion and fuel handling systems*
- *Part 3: Generation and use of protective and reactive atmosphere gases*
- *Part 4: Protective systems*

Introduction

This part of ISO 13577 is a Type C-Standard as defined in ISO 12100.

The machinery concerned and the extent, to which hazards, hazardous situations and events are covered, is indicated in the scope of this part of ISO 13577.

When provisions of this type C standard are different from those which are stated in type A or B standards, the provisions of this type C standard take precedence over the provisions of the other standards, for machines that have been designed and built according to the provisions of this type C standard.

Compliance with product standards, e.g. ISO 22967 or ISO 22968 is not sufficient to ensure the minimum safety requirement for TPE. This part of ISO 13577 shall always have priority for TPE.

Industrial furnaces and associated thermo-processing equipment (TPE) generally consists of the following components:

- processing chamber (e.g. steel construction with lining and/or refractory);
- heating systems;
- protective system;
- control and instrumentation system/operator-control level.

ISO 13577-1 provides the general safety requirements common to TPE. This part of ISO 13577 details in addition specific safety requirements for generation and use of protective and reactive atmosphere gases that are part of TPE as listed in the scope. These requirements establish the minimum acceptable requirements for safety functions required for various processes. Where a process is not part of the TPE, the requirements do not apply.

For example, the minimum requirements for the opening and closing of doors on a TPE does not apply to TPE that do not have doors in their design.

NOTE As stated in its scope, ISO 13577-1 does not cover blast furnaces, converters (in steel plants), boilers and equipment not covered under ISO 12100.

The requirements of protective system are specified in ISO 13577-4.

If a general provision of ISO 13577-1 counters provisions in this part of ISO 13577, the provisions of this part of ISO 13577 take precedence.

It is assumed that TPE will only be operated and maintained by trained personnel.

Industrial furnaces and associated processing equipment — Safety —

Part 3: Generation and use of protective and reactive atmosphere gases

1 Scope

This part of ISO 13577 specifies safety requirements for generation and use of protective and reactive atmosphere gases that are part of industrial thermo-processing equipment (TPE).

NOTE The general safety requirements common to TPE are provided in ISO 13577-1 (see Introduction).

This part of ISO 13577 deals with significant hazards, hazardous situations and events relevant to the generation and use of protective and reactive atmosphere gases created by thermochemical reactions and their use in TPE that are part of TPE as listed in [Clause 4](#) and [Clause 5](#), when used as intended and under the conditions foreseen by the manufacturer.

This part of ISO 13577 covers

- pipework downstream of and including the manual isolating valve,
- equipment for the generation of atmosphere gases,
- additional equipment for the use of atmosphere gases in TPE,
- safety devices, and
- functional requirements for safety related control system

for the generation and use of protective and reactive atmosphere gases.

It applies to the supply of atmosphere gas, source gas, inert gas and process liquids to TPE and their removal from TPE, confined to equipment integrated in the TPE.

This part of ISO 13577 also details the anticipated significant hazards associated with atmosphere gas systems and their use in TPE and specifies the appropriate preventative measures for the reduction or elimination of these hazards.

The pressure hazard of the piping and components covered by this standard is within the maximum pressure/size relationship of group I as described in [Annex C](#).

This part of ISO 13577

- specifies the requirements to be met to ensure the safety of persons and property during installation, commissioning, start up, operation, shutdown and maintenance,
- does not cover the relevant risks involved in the flue gas ducting system when it is not considered a part of TPE,
- is not applicable to utility supply upstream of the TPE main disconnects,
- does not apply to TPE for semi-conductor devices,

ISO 13577-3:2016(E)

- does not apply to TPE with atmosphere, such as air and flue gas from an over stoichiometric combustion,
- does not cover the decommissioning of the TPE,
- does not cover vacuum furnaces,
- does not deal with the hazard of noise which is covered in ISO 13577-1,
- is not applicable to generation and use of atmosphere gas in TPE and associated plant which is manufactured before the date of its publication, and
- gives the necessary requirements for the information for use.

A TPE designed according to this part of ISO 13577 does not create any potentially explosive atmosphere in the area around the TPE and is not designed to be located in an area with a potentially explosive or hazardous atmosphere.

A table of typical protective and reactive gases is given in [Annex B](#).

2 Normative references

The following documents, in whole or in part, are normatively referenced in this document and are indispensable for its application. For dated references, only the edition cited applies. For undated references, the latest edition of the referenced document (including any amendments) applies.

ISO 7-1, *Pipe threads where pressure-tight joints are made on the threads — Part 1: Dimensions, tolerances and designation*

ISO 228-1, *Pipe threads where pressure-tight joints are not made on the threads — Part 1: Dimensions, tolerances and designation*

ISO 5817, *Welding — Fusion-welded joints in steel, nickel, titanium and their alloys (beam welding excluded) — Quality levels for imperfections*

ISO 7005-1, *Metallic flanges — Part 1: Steel flanges*

ISO 7005-2, *Metallic flanges — Part 2: Cast iron flanges*

ISO 8434-1, *Metallic tube connections for fluid power and general use — Part 1: 24 degree cone connectors*

ISO 8434-2, *Metallic tube connections for fluid power and general use — Part 2: 37 degree flared connectors*

ISO 8434-3, *Metallic tube connections for fluid power and general use — Part 3: O-ring face seal connectors*

ISO 12100, *Safety of machinery — General principles for design — Risk assessment and risk reduction*

ISO 13574:2015, *Industrial furnaces and associated processing equipment — Vocabulary*

ISO 13577-1:2012, *Industrial furnaces and associated processing equipment — Safety — Part 1: General requirements*

ISO 13577-2:2014, *Industrial furnaces and associated processing equipment — Safety — Part 2: Combustion and fuel handling systems*

ISO 13577-4, *Industrial furnace and associated processing equipment — Safety — Part 4: Protective systems*

ISO 13849-1, *Safety of machinery — Safety-related parts of control systems — Part 1: General principles for design*

ISO 19879, *Metallic tube connections for fluid power and general use — Test methods for hydraulic fluid power connections*

ISO 23551-1, *Safety and control devices for gas burners and gas-burning appliances — Particular requirements — Part 1: Automatic and semi-automatic valves*

ISO 23551-2, *Safety and control devices for gas burners and gas-burning appliances — Particular requirements — Part 2: Pressure regulators*

IEC 60730-2-5:2011, *Automatic electrical controls for household and similar use—Part 2-5: Particular requirements for automatic electrical burner control systems*

IEC 60730-2-6:2007, *Automatic electrical controls for household and similar use—Part 2-6: Particular requirements for automatic electrical pressure sensing controls including mechanical requirements*

3 Terms and definitions

For the purposes of this document, the terms and definitions given in ISO 13574 and the following apply.

NOTE See [Annex J](#) for the list of terms specified in ISO 13574.

3.1

safety shutdown

function that takes the TPE out of operation and brings it in a defined safe state

Note 1 to entry: The definition is different from safety shutdown according ISO 13574:2015, 2.166 which is applicable to ISO 13577-2.

3.2

flame failure

loss of flame from the normally detected position by any cause other than the action of de-energising the automatic shut-off valves system

Note 1 to entry: The term is used in ISO 13577-2.

3.3

gas generator

equipment that converts or modifies a fluid or a mixture of fluids (gaseous or liquid) into a gas which can be utilized as the controlled atmosphere within the thermo-processing equipment

3.4

endothermic generator

gas generator that produces atmosphere gas by an endothermic reaction

3.5

exothermic generator

gas generator that produces atmosphere gas by an exothermic reaction

3.6

combustible atmosphere gas

any gas mixture that is capable of forming ignitable mixtures with air or oxygen under the conditions of temperature and pressure used in the process, according to the lower explosion level (LEL) of the actual gas mixture

3.7

inert gas

non-combustible gas which will not support combustion and does not react at all

Note 1 to entry: Nitrogen, helium and argon are typical inert gases.

3.8

purge gas

gas which can be used to purge a TPE

Note 1 to entry: A purge gas can safely be used for pre- and post-purging of cold and hot enclosures of TPE.

Note 2 to entry: Typically, purge gases are nitrogen, argon, helium and lean exothermic gas.

3.9

safety purge volume

volume of purge gas needed to displace either air or a combustible gas from a furnace chamber/enclosure to achieve a volume fraction of 1 % or less oxygen and/or a non-combustible atmosphere gas and/or 25 % of the lower flammability limit

Note 1 to entry: Typically, this will be a volume equal to five times the volume of the thermo-processing equipment chamber to be purged, if the purging gas is an inert gas.

Note 2 to entry: Non-combustible atmosphere gas as defined in [3.6](#).

3.10

multi-turn valve

valve which, in order to operate from the fully closed to the fully open position, requires a number of revolutions of the operating key or handwheel to be completed

3.11

safe ignition temperature

<MAC> minimum temperature at which spontaneous, safe auto-ignition of combustible gases occurs

Note 1 to entry: The safe ignition temperature has been established at 750 °C.

3.12

toxic atmosphere gas

gas which, in addition to having asphyxiating properties, also acts as a poison

3.13

internal gas generator

gas generator integrated into or directly connected to a TPE

3.14

gas control equipment

centralized mounting of components such as: pipework, safety components, pressure and flow accessories, assembled in a functional unit

3.15

atmosphere gas

gas that is supplied into or formed in TPE in accordance with a defined specification for thermo-processes

Note 1 to entry: Atmosphere gas is used to react with the material processed or to avoid a reaction with the material processed.

3.16

process liquids

liquids that are supplied to TPE to create an atmosphere gas

4 Safety requirements and measures

4.1 General

Protective and reactive atmosphere gases in TPE are used to react with the material processed or to avoid a reaction with the material processed. Protective and reactive atmosphere gases are fed into the TPE at determined points and are discharged out of the TPE at determined points too.

Protective and reactive atmosphere gases shall only be used in TPE that has been constructed to avoid leakage of the protective and reactive atmosphere gases out of the TPE or ambient air into the TPE.

Electrical circuits shall be designed in accordance with IEC 60204-1.

A risk assessment according to ISO 12100 shall be carried out. Safety functions shall be designed in accordance with ISO 13577-4, where the use of standards for functional safety IEC 62061, ISO 13849-1, IEC 61511 and IEC 61508 is included. [Annex E](#) provides information for the determination of the SIL or PL of safety-related functions covered in this part of ISO 13577.

Specific regional requirements are given in [Annex G](#), [Annex H](#) and [Annex I](#). The safety requirements of [Annex G](#), [Annex H](#) and [Annex I](#) shall ensure at least the equivalent level of safety to the requirements given in this part of ISO 13577.

CAUTION — Toxic hazards for persons occur at lower concentrations than hazards by generation of ignitable atmospheres.

NOTE Requirements for maximum allowable concentrations values are identified by national regulations.

Materials used shall comply with the requirements for gas and liquids (e.g. non-ferrous metals are not suitable for NH₃ and natural rubber is not suitable for natural gas).

For basic configuration of piping system of TPE using atmosphere gas, see [Annex F](#).

4.2 Pipework

4.2.1 General

The pipework design shall take into account the composition and properties (e.g. pressure, temperature, corrosiveness, specific gravity, velocity) of gas and liquids and the need for venting, purging and cleaning.

The pipework material shall comply with the relevant standards.

Due to durability, steel is the preferred material for pipes and components but where appropriate and the same safety levels can be achieved, then other materials may be utilized. Such materials and conditions of service shall be specified in the instruction handbook.

Vibration which may cause damage to pipework, components or safety systems shall be prevented (by firm anchoring and/or use of flexible couplings).

Pipework shall be arranged so that safe isolation of atmosphere gas and process liquids to all parts of the TPE can be guaranteed

NOTE An example is shown in [Figure F.1](#).

The isolation method shall be clearly identified (e.g. by removable spool piece painted in red, blanking plate), and provision for blanking opened pipes shall be provided secured against loss (e.g. by an attached chain).

Use of brass or other copper alloy components in contact with ammonia or dissociated ammonia is not allowed.

4.2.2 Connections

Pipework connections shall be metallic and shall be of threaded, compression, press fittings, flanged welded or brazed types. Threaded connections shall be used only for the following pressure/diameter combinations:

- pressures up to 15 kPa and diameters up to DN 100;
- pressures up to 200 kPa and diameters up to DN 50;
- pressures up to 500 kPa and diameters up to DN 25;
- pressures up to 1 MPa and diameters up to DN 15

For other combinations of pressures and diameters, connections shall be made by means of welded flanges or welded joints. The number of connections shall be kept to a minimum.

For fittings according to ISO 49, the following limitations shall be observed:

- fittings are class “A”;
- maximum allowed pressure is 50 kPa;
- for dimensions DN 25 or less, the maximum pressure is 500 kPa.

Where the equipment has a threaded connection, this thread shall comply with ISO 228-1 or ISO 7-1, as appropriate. The use of threads complying with ISO 228-1 is limited to diameter up to DN 50. In the case of threads according to ISO 228-1, the tightness shall be ensured by a ring gasket. In case of threads according to ISO 7-1 suitable sealants shall be used to ensure tightness. Hemp shall not be used in threaded connections unless reinforced with a suitable sealant.

Other threaded connections shall only be used providing they ensure tight connections and are suitably identified.

The design of pipework shall be such as to avoid tensile loading of the joints.

Compression fittings shall comply with ISO 8434-1, ISO 8434-2 and ISO 8434-3 or ISO 19879. They shall only be used for pressures up to 500 kPa and diameters up to 42 mm.

Where press fitting according to EN 10352:2012-09 are used, they shall comply with the application restrictions (e.g. temperature, vibration, gas, liquids).

Any pipe passing through an unventilated space shall not have a connection except welded joints.

Flanges shall comply with ISO 7005-1 and ISO 7005-2 as appropriate.

Arc welding shall comply with ISO 5817, quality Level C.

4.2.3 Unconnected pipework

Any unconnected pipework shall be plugged, capped or blank flanged by means of metallic parts.

4.2.4 Galvanic cells

The formation of galvanic cell shall be avoided by suitable choice of materials.

4.2.5 Flexible tubing and couplings

Flexible tubing shall comply with the general requirements of [4.2.1](#), together with the following:

- shall be as short as possible;
- shall be suitable for the maximum and minimum working temperatures;

- shall be suitable for a pressure 1,5 times the working operating pressure (with a minimum of 15 kPa), at the maximum and minimum working temperatures;
- shall have a directly accessible, upstream manual shut-off valve;
- shall be mounted in such a way as to avoid distortion, whiplash and damage;
- shall have end fittings as integral parts of the tubing;
- shall be constructed from suitable material both metallic and/or non-metallic selected for the application duty and not be easily damaged.

Couplings for removable equipment shall ensure a gastight connection with the equipment connected and disconnected.

4.2.6 Marking of pipework

Marking of pipework is required which enable medium and flow direction to be identified in accordance with national regulations.

4.2.7 Soundness/Tightness

The pipework shall be tight and shall be designed to withstand the internal pressure. After assembly, the pipework shall be submitted to its test pressure and tested for tightness. The test pressure shall be not less than 1,1 times the maximum working pressure at any point with a minimum of 5 kPa.

The external leakage rate shall not give rise to a dangerous condition, combustible and/or toxic, in the foreseen circumstances of the equipment or installation. The frequency of testing to determine the external leakage shall be specified in the instruction handbook.

NOTE It is generally agreed that an external leak rate of $\sim 1 \text{ dm}^3(\text{n})/\text{h}$ for gas or $1 \text{ cm}^3(\text{n})/\text{h}$ for methanol will not create a dangerous condition in typical ventilated industrial installation.

The external leak rate test method shall take into account the volume, number of connections, test gas, number of valves and component parts contained and temperature. Methods of testing shall include spray bubble leak identification and/or pressure decay test.

4.2.8 Condensate drains

In cases where condensates can create a hazard, means shall be provided at the lowest points of the equipment for draining any condensate. When moist gases are being used, condensate drains of a suitable type shall be installed. Any condensate drains, siphons, etc. shall be in a position such that they can be easily checked. Combustible condensates shall be collected by an appropriate means (e.g. piped into a container).

Valves in condensate drains shall be suitably plugged, capped or blank flanged by metallic parts.

4.2.9 Purge points

Means shall be provided to facilitate purging of pipework during commissioning and maintenance to prevent the forming of an ignitable atmosphere.

All distribution pipework and storage vessels for atmosphere gas shall be designed, so that purging procedures in accordance with 4.6 or in such a manner which excludes the simultaneous presence of combustible gas/air mixtures and an ignition source can be done. Each purging point shall be provided with a valve which shall either

- be fitted with a device to prevent unauthorised operation, or
- be blanked off during normal operation of the plant.

4.2.10 Blow-off and breather pipes or conduits

Where blow-off or breather pipes or conduits are fitted on regulators or relief valves, adequate means shall be provided to facilitate the venting of gas from the system to a safe discharge area.

In case breathers or blow-off pipes are gathered, the cross section of the collector shall be suitable to evacuate simultaneously total flow rates of the exhaust sources.

4.2.11 Pressure relief devices and flame arrestors on pipework

For equipment designed for situations in which flash-backs can occur, flame arrestors and/or pressure relief devices shall be fitted.

Pressure relief devices shall be designed to yield at a pressure below the design pressure of the pipework and shall be positioned such that the discharge flow and the pressure relief device does not constitute a risk to the equipment, personnel or third parties.

A flash-back shall trigger an alarm. The required measures after a flash-back shall be described in the instruction handbook.

4.2.12 Pressure oscillations

The pipework shall be designed so as to avoid the possibility of gas velocities and pressure fluctuations causing oscillations which could cause damage to pipework, components or safety systems (e.g. by designing the correct sizing of pipes or using pressure regulators).

4.2.13 Combustible gas by-pass

By-passes shall not be fitted in parallel with any item of combustible gas safety equipment.

This requirement shall not apply to valve proving systems (see ISO 23551-4) on automatic shut-off valves.

4.2.14 Isolation of required safety devices

Required safety devices (e.g. pressure switches, relief valves) shall not be isolated from the equipment they protect during start-up or operation of the TPE. In case isolating valves cannot be avoided and are mounted between these required devices and the main lines, these isolating valves shall be locked in the open position during operation of the equipment by adequate means (e.g. manual lock).

4.2.15 Vents

Any vent from a gas supply pipe, reaction gas control system, gas/air mixture pipe or generated atmosphere gas line shall be adequately sized for the duty intended.

Any vent which is likely to carry a combustible gas/air mixture and which is fitted with a pilot burner shall be equipped with a flame trap.

Any vent from the mixture supply pipe shall be taken from a point downstream of the flame trap or be fitted with a separate flame trap. Any vent which is not fitted with a pilot burner shall terminate above roof level and be remote from potential sources of ignition, having due regard to the layout of adjacent buildings. These vents shall not be manifold.

4.3 Required safety devices

4.3.1 Atmosphere gas control equipment

4.3.1.1 General

A TPE that generates or uses atmosphere gases shall be equipped with atmosphere gas control equipment.

Atmosphere gas control equipment means a centralized mounting of components assembled in a functional unit such as

- pipework,
- safety devices as referred in [4.3.1.2](#), and
- other pressure and flow accessories (e.g. manometer(s), flow adjusting valve(s), test connection(s) and/or purging nipples).

Atmosphere gas control equipment shall be designed based on the TPE's demand for atmosphere gas supply. It shall be designed with components suitable for this purpose.

The atmosphere gas control equipment shall be placed in a sufficiently ventilated area.

If atmosphere gas control equipment is enclosed and combustible and/or toxic gas or liquids are used, the enclosure shall be sufficiently ventilated and equipped with devices to detect toxic gases. Combustible gas detection should also be considered.

The atmosphere gas control equipment shall be suitably marked to be identified as such using written indications in the languages of the user land.

NOTE Identification of atmosphere gas control equipment can be dealt by national regulations.

The atmosphere gas control equipment shall be freely accessible.

4.3.1.2 Safety devices for introduction of atmosphere gases to TPE

4.3.1.2.1 Manual isolating valve

A manually operated and lockable isolation valve shall be fitted upstream of the first control device in each circuit. Manual isolation valves shall be so designed and positioned as to prevent inadvertent operation but shall be easily accessible and capable of rapid operation when required.

They shall be so designed that the "OPEN" and "CLOSED" positions are readily distinguishable (e.g. a 90° turn valve).

4.3.1.2.2 Filter/strainer

Filters shall be fitted to protect automatic shut-off valves, other controls and pipework.

Special care shall be taken to prevent the ingress of particles, either from the pipework or from the gas and liquids, which would be detrimental to the operation of the equipment by the incorporation of a suitable filter or strainer immediately downstream of the first manual isolating valve of the TPE. Additional filters/strainers may be required (e.g. immediately upstream of the automatic shut-off valve). The filter and/or the strainer shall be positioned in such a way that periodic servicing remains easy. The filtering capacity of the filter/strainer has to be chosen according to the requirements of downstream equipment.

In case of the installation of a by-pass to the filter and/or the strainer, an identical filtering device shall be installed on the by-pass line.

The intervals for checking the filter and/or the strainer shall be specified in the instruction handbook.

The location of filters shall consider service requirements.

NOTE An equipment for purging filters/strainer is in some cases necessary.

4.3.1.2.3 Pressure regulator and over pressure protection

A pressure regulator shall be incorporated when necessary to control the pressure of atmosphere gases.

Gas pressure regulators when fitted shall comply with ISO 23551-2 as appropriate.

If the outlet side of the gas pressure regulator and/or the following line section with equipment up to the TPE is/are not designed for the maximum supply pressure (inlet pressure upstream to the gas pressure regulator under fault conditions) and an overpressure will create a hazard, the following measures shall be applied shutting off the gas supply before an excessively high pressure occurs.

The over pressure cut off device shall be

- a mechanical valve which measures the gas pressure downstream of the gas pressure regulator by means of an impulse line and closes by spring force in case the pressure exceeds the set response pressure, or
- an automatic shut-off valve according to ISO 23551-1 actuated by an overpressure switch according to IEC 60730-2-6 installed downstream of the gas pressure regulator. In this case, signal processing shall fulfil the requirements of a protective system according to ISO 13577-4.

A small capacity relief valve (token relief valve) shall always be applied downstream of the gas pressure regulator if an over pressure cut-off device is installed to vent small leakages of the high pressure cut-off.

Attention shall be paid to the unintended decrease of atmosphere supply to the TPE which can result in unintended disability of maintaining positive pressure of TPE (see [4.4.2](#) and [4.4.4](#)).

Pressure adjustment on the gas pressure regulator shall only be possible with a special tool provided for the task.

4.3.1.2.4 Pressure relief

In situations where gas or especially liquids can be isolated (e.g. between two shut-off valves) and subject to unacceptable pressure rise, relief shall be provided.

4.3.1.2.5 Automatic shut-off valves

With the exception of the safety purge gas, the atmosphere gas and process liquids supply to the TPE shall be under the control of two automatic shut-off valves in series in the pipework in accordance with the following subclauses of ISO 23551-1:2012, unless a risks assessment can demonstrate the suitability of a single automatic shut-off valve:

- 7.1, for general requirements;
- 7.2, for leak tightness;
- 7.5, for durability;
- 7.6.10.1, for the closing function;
- 7.6.10.4, for the closing force;
- 7.6.10.6, for the closing time.

The sealing force for automatic shut-off valves shall be equal or greater than 15 kPa.

The automatic shutoff valve must endure the intended number of cycles in the TPE.

Valves construction and materials shall be suitable for the used gas and liquids.

Automatic shut-off valve shall be capable of withstanding all upstream pressure, backpressure and differential pressure under all process circumstances.

High cycling applications over 100 000 cycles/year shall use only valves that are declared capable of the intended number of cycles.

The instruction handbook shall specify the need to check automatic shut-off valves for correct operation, the procedure to be adopted and the intervals at which this should be carried out and the requirements for replacement. A means to determine when automatic shut-off valves require replacement shall be supplied.

All systems shall have the ability for manual leak testing of the automatic shut-off valve.

NOTE 1 It is commonly agreed that valves are to be tested annually unless longer or shorter testing intervals can be justified by the risk analysis.

Control valves may be used as safety shut-off valves provided they are designed as both safety shut-off and modulation valves and tested for concurrent use.

The automatic shut-off valves shall not open when the limit of any safety condition is reached.

NOTE 2 Example for safety related conditions to be considered are (but not limited to): minimum and maximum gas pressure, failure of power supply and/or other utilities (e.g. compressed air), minimum and maximum operation temperature, minimum and maximum pressure inside the TPE which is not caused by process.

It shall only be possible to manually reset (locally or remotely) the lock out of a closed automatic shut-off valve.

4.3.1.2.6 Flow rate indicators

Flow meters and flow control valves shall be provided for all gases and process liquids introduced into the TPE.

4.3.1.2.7 Non-return valves

Non-return valves shall be provided in the atmosphere gases and process liquids supplies to the TPE.

4.3.1.2.8 Temperature monitoring and control of cooled atmosphere gas

If gas is cooled, so that the temperature of the gas does not exceed the allowed maximum value of the safety relevant components downstream, means to detect over temperature of the gas shall be provided.

If over temperature is detected, at least an alarm shall be caused. The required measures shall be described in the instruction handbook.

For open discharge systems, the cooling water shall be discharged into an open drain such that the flow is visible. There shall be no valves or restrictions in the discharge piping to, or the outlet piping from, the drain.

For closed discharge systems, the cooling water shall be discharged through individual flow indicators. Relief valves shall be installed to relieve any obstructed discharge lines.

4.3.1.3 Safety devices for purge gas

Manual isolation valves shall be proven in the fully open position during operation. If it is proven automatically, then it shall meet the requirements of a protective system according to ISO 13577-4.

Automatic valves for emergency safety purge shall be normally open. Automatic valves for emergency shall have a manual by-pass valve piped in parallel.

When used, timers for purging shall comply with IEC 60730-2-5, if applicable.

Purge gas supply pipework for fuel gas pipework/combustion chamber and purge of atmosphere gas pipework shall be securely isolated or shall not commonly be used.

4.3.2 Other safety devices

4.3.2.1 Trap seals

If a trap seal is used to contain combustible or toxic atmosphere, its performance shall be monitored. Any detected malfunction shall initiate a corrective procedure.

NOTE 1 Performance can be monitored with systems such as level sensors for liquids or gas warning systems for dry traps.

NOTE 2 Examples of corrective procedure may include audible alarms, automatic refill, shutdown, etc.

4.3.2.2 Safety devices for gas boosters/compressors

Where a gas booster/compressor is used, a low-pressure protection shall be fitted in the gas inlet system to the booster/compressor to ensure that depressurisation of upstream gas systems cannot occur. This low pressure protection shall cause shutdown of the booster/compressor in the event of reduced pressure and shall prevent automatic re-start on pressure restoration.

Gas pressure detectors shall comply with IEC 60730-2-6 or shall be evaluated to ensure appropriated reaction time and accuracy.

Attention shall be paid to the unintended decrease of atmosphere gas supply to the TPE which can result in unintended disability of maintaining positive pressure of TPE.

A suitable non-return valve shall be fitted between the booster/compressor outlet and the inlet to any storage vessel incorporated in the system.

The booster/compressor shall be fitted with a device to prevent the pressure from exceeding a pre-determined safe value.

4.3.2.3 Devices for vacuum conditions

Where atmosphere gas or process liquids additions are supplied to TPE that are operating under, or may induce, a vacuum, then special consideration shall be given to the selection of any controls which can be subject to vacuum during both normal and abnormal conditions.

4.4 Requirements for the use of atmosphere gases

4.4.1 Prevention of potential ignitable atmospheres

4.4.1.1 General

If combustible atmosphere gases are used, the formation of ignitable atmospheres shall be avoided. The following subclauses detail established process requirements to avoid the formation of ignitable atmospheres inside a TPE.

The following methods shall be used, either singly or in combination.

4.4.1.2 Safety temperature

If for the safe operation of a TPE, the operating temperature shall be above the safe ignition temperature (750 °C), the temperature shall be monitored.

The start of admittance of the combustible atmosphere gas supply shall be interlocked with the safe ignition temperature. This function shall meet the requirements of a protective system according to ISO 13577-4.

If the temperature in the TPE falls below the safe ignition temperature and a combustible atmosphere gas is used and a hazardous situation can occur, an alarm shall be caused. If this situation cannot be changed within a predetermined time, an emergency safety purge shall be performed (see 4.4.4). This function shall meet the requirements of a protective system according to ISO 13577-4.

4.4.1.3 Monitoring of TPE pressure

A pressure and/or a flow interlock and alarm shall be provided where a combustible atmosphere is used and safe operation of TPE is dependent upon the operating furnace pressure being maintained and monitored above a predetermined limit. The minimum and maximum pressure and/or flow levels shall be specified in the instruction handbook. This system shall prevent the introduction of air in abnormal situation.

If the pressure in the TPE or the flow rate to the TPE falls below the safe limit and a combustible atmosphere gas is used, an alarm shall be caused and an emergency safety purge shall be performed (see 4.4.4). This function shall meet the requirements of a protective system according to ISO 13577-4.

4.4.1.4 Controlling process air/oxygen of TPE operating below 750 °C

NOTE 1 Controlling process air/oxygen can be required on TPE performing the oxy-nitriding process.

When process air/oxygen is used with a combustible special atmosphere in a TPE operating below 750 °C, the furnace's oxygen content shall be maintained below a predetermined safe level.

The means of maintaining the above requirement shall be specified in the instruction handbook.

NOTE 2 The means of maintaining the above requirement can include an oxygen sensor/controller to limit the oxygen content and a flow control to limit process air/oxygen below set flow rates.

If the oxygen content in the TPE is not maintained below the predetermined safe level, an alarm shall be caused and the following action shall be implemented (see 4.4.4):

- closure of the combustible atmosphere supply valve(s);
- closure of process air/oxygen gas supply valve(s);
- emergency safety purge.

These functions shall meet the requirements of a protective system according to ISO 13577-4.

4.4.1.5 Monitoring of atmosphere gas and process liquid supply

If safety is dependent upon the atmosphere gas or process liquid flow rate, then a device shall be fitted to prove that an adequate supply is available. If, for any reason, the supply is not sufficient, an alarm shall occur and an emergency safety purge shall be performed (see 4.4.4). This function shall meet the requirements of a protective system according to ISO 13577-4.

4.4.2 Monitoring of TPE doors movements

If a combustible atmosphere gas is used and temperature inside next to the door is below than 750 °C, a means of ignition shall be provided at each door or process opening to ignite the atmosphere gases.

NOTE Means of ignition of atmosphere gases could be flame curtain, pilot burner, hot surface ignition, etc.

Any means of ignition shall be proven and supervised.

The gas supply valve for flame curtains shall not be opened until the source of ignition of the flame curtain is established. The flame curtain has to cover the full width of the door. Flame curtains shall be supervised in accordance to ISO 13577-2:2014, 4.2.6.4 on point of ignition and at least at the end(s) of the flame curtain at a height that will ensure ignition of the atmosphere gas, when the doors are being opened.

Failure of any means of ignition shall cause an alarm and an interlock to the doors shall prevent opening. This function shall meet the requirements of a protective system according to ISO 13577-4.

If the means of ignition fails during the doors movement and the atmosphere in the TPE could ignite in an uncontrolled manner, the door shall move to an end position

An alternative to opening the doors of the TPE without means of ignition is when TPE has an automatic system for purge cycle, interlocking doors in closed position until the atmosphere is non-combustible and nontoxic.

4.4.3 Supervision of the means of ignition at the point of combustible atmosphere gas discharge

Means of ignition shall be fitted at each point of gas discharge. The ignition means shall be so designed that safe ignition of discharge atmosphere gas is always ensured.

NOTE Means of ignition can be pilot burner, electric ignition, etc.

Start of supply of combustible atmosphere gas is only permitted, if the mean of ignition at the point of gas discharge is in operation. This function shall meet the requirements of a protective system according to ISO 13577-4.

Failure of the means of ignition shall cause an alarm.

The instruction handbook shall detail process and procedure for dealing the alarm situation.

4.4.4 Emergency safety purge

Where an emergency safety purge is required a supply of purge gas of at least the safety purge volume of the TPE shall be available.

The supply of purge gas of sufficient quantity, pressure and flow rate to effect a safety purge (see ISO 13574:2015, 2.143) shall be provided and its availability shall be proved before the atmosphere gas or process liquids are admitted. Any unnecessary obstacle in the supply line for emergency safety purge shall be avoided.

Before a remaining safety purge gas falls below the required quantity, an emergency safety purge shall be initiated. If safety purge gas (e.g. nitrogen) is missing, operation shall not be started (interlock). These functions shall meet the requirements of a protective system according to ISO 13577-4.

The system shall be designed to operate in upset conditions (e.g. power outage).

The performance of an emergency safety purge procedure includes

- closure of the combustible atmosphere gas supply valve(s), and
- admittance of purge gas into the TPE.

4.5 Change of atmosphere

4.5.1 General

Changing atmosphere means: air to atmosphere gas or atmosphere gas to air.

The following subclauses detail established process requirements for safety controls for purging atmosphere gas pipework and TPE that can be used in the design of equipment for atmosphere gases. The change of atmosphere is part of the automatic control system.

Specific instructions on the procedure for admitting atmosphere gas into, and removing atmosphere gas from, TPE and enclosures shall be provided by the manufacturer in accordance with the purging method(s) adopted.

The effects of doors (operational speed and sequencing) and/or other openings on safe purging shall be taken into account in the selection and use of purging procedures.

The following purging methods shall be used, either singly or in combination.

Possible procedures for changing of atmospheres for

- TPE at or above 750 °C operation temperature:
 - self-ignition (see [4.5.3](#));
 - purge (see [4.5.2](#));
 - burning (see [4.5.4](#));
 - evacuate (see [4.5.5](#));
- TPE below 750 °C operation temperature:
 - purge (see [4.5.2](#));
 - evacuate (see [4.5.5](#)).

The principle procedures for the change of atmosphere are shown in [Figure D.1](#).

4.5.2 Purge with purge gas

4.5.2.1 General

The change of atmosphere in a TPE from air to a combustible gas or from a combustible gas to air can be done by using a purge gas.

4.5.2.2 Purge with purge gas to change atmosphere from air to combustible gas

If a combustible atmosphere gas or process liquid is introduced into a TPE or enclosures (which operate below 750 °C or which operate above 750 °C with a purge done below 750 °C), then its introduction shall be preceded by an purge gas purge to remove air until the oxygen content is a volume fraction of 1 % or less. This function shall meet the requirements of a protective system according to ISO 13577-4.

4.5.2.3 Purge with purge gas to change atmosphere from combustible gas to air

Prior to shutting off the supply of combustible atmosphere gas or process liquids to a TPE or enclosure (operating below 750 °C or which operate above 750 °C with a purge done below 750 °C) an purge with purge gas shall be initiated and the flow adjusted to the required value. The supply valves shall then be closed and the purge gas shall purge continued until 50 % of LFL is reached. This function shall meet the requirements of a protective system according to ISO 13577-4. The purge gas may then be replaced by air.

If the atmosphere gas supply source can be adjusted to provide a non-combustible atmosphere gas with less than 1 % oxygen this gas may be utilized as the purge gas purge.

4.5.3 Purge with self-ignition

4.5.3.1 General

The change of atmosphere in a TPE from air to a combustible gas or from a combustible gas to air, can be accomplished using the self-ignition of combustible gases at temperatures above 750 °C.

Combustible atmosphere gas or process liquids shall only be introduced in the TPE if the temperature in the TPE is above the safe ignition temperature.

4.5.3.2 Purge with self-ignition to change atmosphere from air to combustible gas

If a combustible atmosphere gas or process liquids are introduced into a TPE zone where the temperature is maintained at 750 °C or more then purging of the furnace chamber may continue until all the air has been consumed and/or displaced by the incoming combustible atmosphere gas or process liquids.

4.5.3.3 Purge with self-ignition to change atmosphere from combustible gas to air

If air is introduced into a TPE zone where the temperature is maintained at 750 °C or more to purge a combustible atmosphere from the TPE zone, then the supply valves of the combustible atmosphere gas or process liquids shall be closed, thus, allowing remaining combustible atmosphere within the TPE to be consumed by combustion.

Products of combustion shall be vented and doors may be opened. The ingress of air shall be such that the pressure and temperature resulting from the combustion will not create a hazardous condition.

4.5.4 Change of atmosphere by burning

4.5.4.1 General

This method of changing of atmosphere shall not be used when furnace atmosphere gas circulation fans are operating in the zone or enclosure.

NOTE A change of atmosphere procedure by self-ignition is possible for furnaces operating below 750 °C, provided that the safety ignition temperature is exceeded during the change of atmosphere.

4.5.4.2 Change of atmosphere by burning from air to combustible gas

If the TPE zone or enclosure into which the combustible atmosphere gas is introduced is at a temperature below 750 °C, changing of atmosphere without the use of purge gas is only permitted if a reliable means of ignition is proven at the position where the combustible atmosphere gas is introduced. This function shall meet the requirements of a protective system according to ISO 13577-4.

4.5.4.3 Change of atmosphere by burning from combustible gas to air

If the TPE zone or enclosure is at a temperature below 750 °C the change of atmosphere from combustible gas to air may be done by opening the door to this zone or enclosure according to [4.4.2](#).

NOTE The change of atmosphere (burnout) will start at the moment the door is opened, as the combustible atmosphere gas from inside the chamber and the air outside the chamber are ignited, induced by the mean of ignition and a controlled burnout will progress inside the chamber.

If the TPE zone or enclosure subject for change of atmosphere is more than 0,25 m higher than the upper edge of door opening, an extra means of induced ignition shall be located in this upper chamber area next to the exit into the atmosphere burn-off area on top of the chamber.

4.5.5 Purge by evacuation

4.5.5.1 General

The change of atmosphere in a TPE from air to a combustible gas or from a combustible gas to air can be also done by evacuation.

4.5.5.2 Purge by evacuation to change atmosphere from air to combustible gas

The air shall be evacuated to a pressure of 4,5 kPa absolute. Subsequently, the TPE shall be flooded with a purge gas up to the pressure of the prevailing atmospheric value. This function shall meet the requirements of a protective system according to ISO 13577-4. As an effect, the content of oxygen is a volume fraction of 1 % or less.

4.5.5.3 Purge by evacuation to change atmosphere from combustible gas to air

The evacuation of a combustible gas is only valid if the tightness of the TPE is ensured and no air can be pulled in and mixed with the combustible gas.

The combustible gas shall be evacuated to a safe pressure, depending on the atmosphere, and then the TPE shall be flooded with a purge gas or air up to the pressure of the prevailing atmospheric value. This function shall meet the requirements of a protective system according to ISO 13577-4.

When calculating safe pressure, the aspects of combustible or toxic atmosphere gases shall be considered.

4.6 Interfaces to exhaust systems for combustible or toxic atmosphere gases

4.6.1 Exhaust of burned gases

4.6.1.1 General

In the instruction handbook, the manufacturer shall define

- the maximum possible flow of burned gases from the TPE, and
- in case the manufacturer supplies parts of the exhaust system such as suction hoods, the manufacture shall also define the connecting cross section and the needed draft pressure.

The exhaust gas system shall be designed according to these defined requirements.

The proper function of this system has to be verified during the commissioning.

4.6.1.2 Natural draft exhaust gas system

No signal for proper function of the exhaust gas system to the TPE is needed.

4.6.1.3 Vented exhaust gas system

The function of the exhaust system has to be ensured in case of a power blackout.

A signal from the exhaust gas system to the TPE is needed, which indicates the discharge of the maximum possible gas flow of burned gases.

If the discharge of the exhaust gas is disturbed, an alarm shall be caused. If this situation cannot be changed within a predetermined time, it shall be followed by

- safety shutdown of TPE operating below 750 °C to prevent any hazardous situation arising, and

ISO 13577-3:2016(E)

- closure of the atmosphere gas and process liquids supply valve(s).

In the calculation of the predetermined, time such factors as gas flow, work space volume, work space venting have to be considered.

4.6.2 Gathering of gases without burning and a closed system

The system of gathering gases shall be designed in a way that no reaction back on the TPE will be caused.

NOTE The gathered gas may be used in other processes, e.g. as a fuel gas.

The gathering system shall be able to remove the gas flow from the TPE at any time, e.g. in situations as power blackout or stop of the planned processing of the gas.

The creation of an explosive mixture in the gathering system has to be prevented at all possible operating modes.

A signal from the gas gathering system to the TPE is needed, which indicates the proper removal of the gas flow.

If the gathering of the gas is disturbed, an alarm shall be caused.

This shall be followed by

- safety shutdown of TPE operating below 750 °C to prevent any hazardous situation arising, and
- closure of the atmosphere gas and process liquids supply valves.

5 Additional requirements for the generation of atmosphere gases

5.1 General

This clause describes the additional functional requirements for

- gas supplies,
- liquid supplies,
- flame detection,
- atmosphere gas generating burners,
- special requirements for different types of generators, and
- post-treatment of generated gases.

The instruction handbook shall specify that the ventilation of the building in which the atmosphere gas generator is housed shall be such that it allows a supply of sufficient volume of clean fresh air to reach the atmosphere gas generator under all conditions.

Fuel handling system for the generation of atmosphere gases shall be in accordance with ISO 13577-2, if applicable.

5.2 Gas and process liquid supplies

5.2.1 Air supplies

Where the air is supplied under pressure, a suitable device for proving the air supply to the atmosphere gas generator shall be fitted. The air supply shall be proved before opening the source gas automatic shut-off valve.

5.2.2 Reaction mixture supplies

If a system includes combustible gas/air mixtures, the mixture supply pipe shall be kept as short as possible. The equipment shall be designed so that a flash back will not occur.

5.2.3 Generated atmosphere gas distribution

5.2.3.1 Valves

The generated atmosphere gas distribution system from the gas generator shall be fitted with a manual shut-off valve and a relief valve upstream of this shut-off valve.

5.2.3.2 Condensate traps

Means shall be provided to ensure that generated atmosphere gas is not discharged from condensate traps other than via suitably designed vents into an area where it does not create hazards.

5.2.3.3 Excess of generated atmosphere gas

Means shall be provided for the safe disposal of excess (surplus) generated atmosphere gas discharged from the relief valve. Depending upon specific local circumstances and the analysis of the generated atmosphere gas, safe disposal shall be accomplished by either

- burning off of the generated atmosphere gas and safe disposal of the combustion products; the pilot burner for this purpose shall be suitably protected and an alarm given on flame failure, or
- venting to an area where it does not create hazards.

5.3 Flame detection

Flame detection shall be in accordance with ISO 13577-2:2014, 4.2.6.

5.4 Burners generating exothermic gases

A means of ignition of the burner shall be provided.

Ignition shall be accomplished by either

- a properly located and fixed interrupted pilot,
- a properly located and removable interrupted pilot, or
- direct ignition of the main flame at the minimum practicable rate.

In all cases, ignition shall comply with ISO 13577-2:2014, 4.2.5.3 and 4.2.7.

5.5 Special requirements for different types of generator

5.5.1 Requirements for endothermic generators

5.5.1.1 Source gas supplies

If the combustion and reaction atmosphere gases are supplied from a single main inlet, steps shall be taken to ensure that varying flow rates do not adversely affect the control of combustion and reaction.

5.5.1.2 Catalyst regeneration

Regeneration of the catalyst of endothermic generators (i.e. burning off of carbon deposits) is usually carried out by passing only air through the retort at a suitable temperature. In order to carry out this procedure it is necessary to energize the reaction air supply control system with the reaction gas supply control system isolated and locked out. This procedure shall be described in the instruction handbook.

The design and instructions for use of systems incorporating catalyst regeneration shall ensure that the reaction air cannot be fed into the atmosphere gas distribution pipework of the TPE or enclosures.

5.5.1.3 Mixture supplies

If a mechanical gas/air mixing machine or a similar pre-mixing system is used, a flame trap or other suitable devices shall be provided to protect against flash-back in the mixture supply pipe. The flame trap shall be fitted as close as practicable to the atmosphere gas generator retort inlet respectively. The length of the mixture supply pipe between the device and the retort shall be kept as short as possible.

The flame trap or other suitable device shall incorporate a sensor to detect flash-back. Detection of flash-back shall result in a lockout of the generator.

If a mechanical gas/air mixing machine is used, there shall be no gas off-take from the gas line between the manual reaction gas isolating valve and the mixing machine inlet.

5.5.1.4 Temperature monitoring

The temperature of the endothermic generators shall be monitored. The admittance of the gas/air-mixture to the generator shall only be possible if the temperature of the generator is above a predetermined safe limit. This function shall meet the requirements of a protective system according to ISO 13577-4.

5.5.2 Requirements for exothermic generators

5.5.2.1 Mixture supplies

If a mechanical gas/air mixing machine or a similar pre-mixing system is used, a flame trap or other suitable devices shall be provided to protect against flash-back in the mixture supply pipe. The flame trap shall be fitted as close as practicable to the burner of the exothermic generator. The length of the mixture supply pipe between the device and the burner shall be kept as short as possible.

The flame trap or other suitable device shall incorporate a sensor to detect flash-back. Detection of flash-back shall result a lockout of the generator.

If a mechanical gas/air mixing machine is used, there shall be no gas off-take from the gas line between the manual reaction gas isolating valve and the mixing machine inlet.

5.5.2.2 Pre-purge before start-up

Pre-purging of exothermic generator and any external coolers shall be in accordance with ISO 13577-2:2014, 4.3.7.1.

5.6 Post-treatment of generated atmosphere gases

NOTE Post-treatment of generated atmosphere gases can be done to enhance the suitability for a specific process. Drying or dehumidifying and/or separating of unwanted components, as well as addition of other gases, may be done.

If equipment for post treatment is used (either integrated into the generator plant or placed between generator and furnace), it shall meet corresponding safety level requirements as prescribed for the generator plant.

Equipment for treatment of atmosphere gases has to be designed for the purpose. Special attention shall be given to molecular sieves. It shall be possible to isolate containers from process gas lines for maintenance purposes (e.g. changing sieve mass).

6 Verification of the safety requirements and/or measures

[Table 1](#) shall be used as a checklist for manufacturers to prepare their own specific table of methods for verifying that the safety requirements and measures described in [Clause 4](#) and [Clause 5](#) are met. It should contain references to the respective clauses of this part of ISO 13577.

Table 1 — Verification of the safety requirements and/or measures

| Clause | Safety requirements and/or measures | Visual inspection | Functional test | Measuring | Examination of drawings/calculations |
|---------------------------|---|-------------------|-----------------|-----------|--------------------------------------|
| | | Note 1 | Note 2 | Note 3 | Note 4 |
| 4 | Safety requirements, measures and verification means | | | | |
| 4.1 | General | x | | | x |
| 4.2 | Pipework | | | | |
| 4.2.1 | General | x | | | x |
| 4.2.2 | Connections | x | | | x |
| 4.2.3 | Unconnected pipework | x | | | |
| 4.2.4 | Galvanic cells | x | | | x |
| 4.2.5 | Flexible tubing and couplings | x | | | x |
| 4.2.6 | Marking of pipework | x | | | |
| 4.2.7 | Soundness/Tightness | x | | | x |
| 4.2.8 | Condensate drains | x | | | |
| 4.2.9 | Purge points | x | | | x |
| 4.2.10 | Blow-off and breather pipes or conduits | x | | | x |
| 4.2.11 | Pressure relief devices and flame arrestors on pipework | x | | | |
| 4.2.12 | Pressure oscillations | x | | | x |
| 4.2.13 | Combustible fluid by-pass | x | | | |
| 4.2.14 | Isolation of required safety devices | x | | | x |
| 4.2.15 | Vents | x | | | x |
| 4.3 | Required safety devices | | | | |
| 4.3.1 | Gas control equipment | x | | | |
| 4.3.1.1 | General | x | | | x |
| 4.3.1.2 | Safety devices for introduction of protective or reactive atmosphere gases to furnace | x | | | |
| 4.3.1.2.1 | Manual isolating valve | x | | | |
| 4.3.1.2.2 | Filter/strainer | x | | | |

NOTE 1 Visual inspection is carried out for testing the required characteristics and properties by visual examination of the delivered equipment and components.

NOTE 2 The functional test will show whether the parts in question function in such a way as to satisfy the requirements.

NOTE 3 Verification by means of measuring instruments is used to check whether the requirements are fulfilled within the specific limits.

NOTE 4 Drawings and calculations are used to check whether the design characteristics of the components meet the specific requirements

Table 1 (continued)

| Clause | Safety requirements and/or measures | Visual inspection | Functional test | Measuring | Examination of drawings/calculations |
|---------------------------|--|-------------------|-----------------|-----------|--------------------------------------|
| | | Note 1 | Note 2 | Note 3 | Note 4 |
| 4.3.1.2.3 | Pressure regulator and over pressure protection | x | | | |
| 4.3.1.2.4 | Pressure relief | x | | | |
| 4.3.1.2.5 | Automatic shut-off valves | x | | | |
| 4.3.1.2.6 | Flow rate indicators | x | | | |
| 4.3.1.2.7 | Non-return valves | x | | | |
| 4.3.1.2.8 | Temperature control devices of cooled atmosphere gas | x | | | x |
| 4.3.1.3 | Safety devices for purge gas | x | | | |
| 4.3.2 | Other safety devices | x | | | |
| 4.3.2.1 | Trap seals | x | | | |
| 4.3.2.2 | Safety devices for gas boosters/compressors | x | | | |
| 4.3.2 | Devices for vacuum conditions | x | | | |
| 4.4 | Requirements for the use of protective or reactive atmosphere | | | | |
| 4.4.1 | Prevention of potential explosive atmospheres | x | | | |
| 4.4.1.2 | Safety temperature | x | | | |
| 4.4.1.3 | Monitoring of TPE pressure | x | | | |
| 4.4.1.4 | Controlling process air/oxygen of TPT operating under 750 °C | x | | | |
| 4.4.1.5 | Monitoring of atmosphere gas supply | x | | | |
| 4.4.2 | Monitoring of TPE doors movement | x | | | |
| 4.4.3 | Supervision of the means of ignition at the point of combustible gas discharge | x | | | |
| 4.4.4 | Emergency safety purge | x | | | x |
| 4.5 | Change of atmosphere | x | | | |
| 4.5.2 | Purge with purge gas | x | | | |
| 4.5.2.2 | Purge with purge gas to change atmosphere from air to combustible gas | x | | | |
| 4.5.2.3 | Purge with purge gas to change atmosphere from combustible gas to air | x | | | |
| 4.5.3 | Purge with self-ignition | x | | | |
| 4.5.3.2 | Purge with self-ignition to change atmosphere from air to combustible gas | x | | | |
| 4.5.3.3 | Purge with self-ignition to change atmosphere from combustible gas to air | x | | | |
| 4.5.4 | Change of atmosphere by burning | x | | | |

NOTE 1 Visual inspection is carried out for testing the required characteristics and properties by visual examination of the delivered equipment and components.

NOTE 2 The functional test will show whether the parts in question function in such a way as to satisfy the requirements.

NOTE 3 Verification by means of measuring instruments is used to check whether the requirements are fulfilled within the specific limits.

NOTE 4 Drawings and calculations are used to check whether the design characteristics of the components meet the specific requirements

Table 1 (continued)

| Clause | Safety requirements and/or measures | Visual inspection | Functional test | Measuring | Examination of drawings/calculations |
|-------------------------|--|-------------------|-----------------|-----------|--------------------------------------|
| | | Note 1 | Note 2 | Note 3 | Note 4 |
| 4.5.4.2 | Change of atmosphere by burning from air to combustible gas | x | | | |
| 4.5.4.3 | Change of atmosphere by burning from combustible gas to air | x | | | |
| 4.5.5 | Purge by evacuation | x | | | |
| 4.5.5.2 | Purge by evacuation to change atmosphere from air to combustible gas | x | | | |
| 4.5.5.3 | Purge by evacuation to change atmosphere from combustible gas to air | x | | | |
| 4.6 | Interfaces to exhaust systems for combustible or toxic atmosphere gases | | | | |
| 4.6.1 | Exhaust of burned gases | x | | | |
| 4.6.1.2 | Natural draft exhaust gas system | x | | | |
| 4.6.1.3 | Vented exhaust gas system | x | | | x |
| 4.6.2 | Gathering of gases without burning and a closed system | x | | | |
| 5 | Additional requirements for the generation of protective and reactive atmosphere gases | | | | |
| 5.2 | Gas and process liquid supplies | x | | | |
| 5.2.1 | Air supplies | x | | | |
| 5.2.2 | Reaction mixture supplies | x | | | |
| 5.2.3 | Generated atmosphere gas distribution | x | | | |
| 5.2.3.1 | Valves | x | | | |
| 5.2.3.2 | Condensate traps | x | | | |
| 5.2.3.3 | Excess of generated atmosphere gas | x | | | |
| 5.3 | Flame detection | x | | | |
| 5.4 | Gas atmospheric generating burners | x | | | |
| 5.5 | Special requirements for different types of generator | | | | |
| 5.5.1 | Requirements for endothermic generators | | | | |
| 5.5.1.1 | Source gas supplies | x | | | |
| 5.5.1.2 | Catalyst regeneration | x | | | |
| 5.5.1.3 | Mixture supplies | x | | | x |
| 5.5.1.4 | Temperature monitoring | x | | | |
| 5.5.2 | Requirements for exothermic generators | | | | |
| 5.5.2.1 | Mixture supplies | x | | | |
| 5.5.2.2 | Pre-purge before start-up | x | | | |
| 5.6 | Post-treatment of generated atmosphere gases | x | | | |

NOTE 1 Visual inspection is carried out for testing the required characteristics and properties by visual examination of the delivered equipment and components.

NOTE 2 The functional test will show whether the parts in question function in such a way as to satisfy the requirements.

NOTE 3 Verification by means of measuring instruments is used to check whether the requirements are fulfilled within the specific limits.

NOTE 4 Drawings and calculations are used to check whether the design characteristics of the components meet the specific requirements

7 Information for use

7.1 General

The manufacturer of the TPE shall provide an instruction handbook which contains the necessary information for generation and use of atmosphere gases system. The format and content shall comply with ISO 12100:2010, 6.4.

The information for use shall be written in the user's language and shall contain one copy in the original language chosen by the manufacturer.

The information for use shall contain details for commissioning, start-up and use together with information for test procedure and general maintenance of the generation and use of atmosphere gases system of the TPE and its intended use defined by the manufacturer.

7.2 Marking

The minimum information marked on the TPE is given in ISO 13577-1:2012, Clause 6.

The pipework shall be identified by

- colour, and/or
- sign,
- medium,
- flow direction.

7.3 Instruction handbook

7.3.1 General

The instruction handbook shall be in accordance with the requirements specified in ISO 13577-1:2012, 6.4.

For the part generation and use of atmosphere gases system, the instruction handbook of the TPE shall at least contain the following details:

- exact description of the generation and use of atmosphere gases system of the TPE and of the safety equipment;
- complete range of application of the generation and use of atmosphere gases system of the TPE (tolerable range of application, if necessary);
- schematic description of the safety functions.

Moreover, the following aspects are to be treated by the instruction handbook:

- operation of generation and use of atmosphere gases system of the TPE only by competent personnel according to the conditions of use defined by the manufacturer;
- information on correct work place of operator.

The instruction handbook shall deal with start-up, operation, normal and emergency shutdown.

7.3.2 Description of equipment

The instruction handbook shall contain the following information:

- description of the generation and use of atmosphere gases system of the TPE, including as built schematic diagrams of pipework and electrical wiring;
- list of all safety and control equipment parts with their settings and an indication of the relevant standards;
- list of equipment settings/adjustments as made during final;
- description of any deviations from the requirements of relevant standards in the construction and/or function of parts of the generation and use of atmosphere gases system of the TPE;
- requirements for handling the waste products of combustion from the TPE.

All the information given on the marking plate(s) shall be repeated together with information relevant to generation and use of atmosphere gases.

7.3.3 Inspection procedures

The instruction handbook shall contain details of inspection intervals and periodic checking procedures for

- leak tightness of all pipework; periodic checking of leak tightness should be carried out at intervals to be determined by consideration of the operating conditions and material of construction,
- leak tightness of the TPE,
- leak tightness check of the valves,
- leak tightness check of the filter and/or the strainer,
- all safety equipment, warning devices and automatic shut-off valves,
- safety functions in order to ensure that these functions are not impaired by concealed faults or errors.

A documentation form shall be included in which the date, the results and the person who carried out the checks are recorded together with the date of the next inspection.

The requirements for the leak inspection intervals and procedures shall take in account all hazards of the used fluids (e.g. creating of explosive atmospheres, intoxication, asphyxiation or cauterization).

Intervals for leak inspection can be extended and the procedures can be modified if gas measuring and warning devices are installed.

7.3.4 Commissioning, start-up and operating procedures

7.3.4.1 General

The instruction handbook shall provide details of the procedure for commissioning, start up, including preliminary checks (e.g. cleaning of pipework), description of conditions and a list of manually and automatically operated system checks, e.g. opening equipment doors, if applicable.

Attention shall be drawn to the necessity of ensuring that the pipework is free of debris, welding slag, etc. after initial commissioning, before the equipment is put into service, after maintenance or long periods of shutdown.

ISO 13577-3:2016(E)

The instruction handbook shall provide information on special allowances or requirements if applicable for

- pre-purge, the exhausting of atmosphere gases,
- exhausting of combustion products, and
- conditions for use and discharge of fluid such as cooling water.

7.3.4.2 Conditions for start-up

The instruction handbook shall provide information when starting a TPE with an inside temperature below 750 °C, which does not contain a protective or reactive atmosphere, furnace doors in vestibules shall be kept open until normal introduction of atmosphere is activated.

The instruction handbook shall provide information that attention should be given to all possibilities for forming an unintended combustible atmosphere in closed chambers.

NOTE Purging with purge gas is an alternative.

7.3.4.3 Operation condition

The instruction handbook shall provide information about the hazards by accumulation of gases from leakages in confined spaces (e.g. TPE-chambers, pits, manholes, cellars and peaked roofs, etc.).

The main hazards are caused by

- gases having a higher density than air,
- toxic gases and liquids, or
- combustible gases and liquids.

A recommendation shall be made that

- users provide operators with training for safe working practices in these spaces, and
- persons entering these spaces use portable gas detection units and personal protective equipment.

7.3.5 Shutdown procedures

The instruction handbook shall provide information on any special requirements, together with a description of measures to be taken in the event of a safety shutdown.

Any time a TPE is not operating, all atmosphere gas and process liquids pipework shall be safely closed and locked.

The instruction handbook shall set down any special requirements for lock-out and/or emergency shutdown and any special measures for subsequent re-start.

An information sheet containing the information required by this clause shall be provided for display at the equipment control panel or at a defined nearest place.

The instruction handbook shall provide information on special allowances or requirements if applicable for

- safe condition, and
- putting the TPE out service.

Where the possibility of combustible residual gases in a non-operating furnace exists, doors shall be fixed in the open position and the venting of these residual gases shall be addressed in the instruction handbook.

7.3.6 Maintenance procedures

The instruction handbook shall contain details of the maintenance intervals and procedures for all parts that require maintenance, replacement and/or repair of items of safety equipment. Means to permit the operator to determine when safety devices require replacement shall be supplied.

Documentation forms with dates of last and next maintenance and the contact information (such as addresses, telephone, fax numbers, e-mail, website and helpdesk coordinates) of maintenance and repair services shall be provided.

The instruction handbook shall provide information on special allowances or requirements if applicable for

- storage of the furnace atmosphere in isolation,
- accessible TPE,
- disconnection and/or closing and locking of atmosphere gas and process liquids during maintenance and access to TPEs,
- leak-proof isolation atmosphere gas and process liquid supply to the TPE (removable spool pieces or blanking plates), and
- environment condition inside furnace chamber to perform (maintenance) work (e.g. oxygen content and no detection of CO).

7.3.7 Documentation

Provision shall be made for recording revisions to the instruction handbook in the event of modification of the equipment (e.g. by repair, modernization or replacement of parts, change of operating conditions).

Annex A (informative)

List of significant hazards

This annex contains all the significant hazards, hazardous situations and events, as far as they are dealt with in this part of ISO 13577, identified by risk assessment as significant for this type of equipment and which require action to eliminate or reduce the risk. The following significant hazards can occur in the use of TPE.

Table A.1 — List of significant hazards

| Clause | Hazards | Location | Relevant clauses of ISO 13577-1:2012 | Relevant clauses of this part of ISO 13577 |
|----------|--|--|--------------------------------------|---|
| | Hazards, hazardous situation and hazardous events | | | |
| 1 | Mechanical hazards | | | |
| 1.1 | High pressure fluid injection or ejection hazard | Pipework | 4.2.7 | 4.2.1 , |
| 2 | Electrical hazards | | | |
| 2.1 | Electrical contact direct or indirect with live parts | Control system, power supply to the machine and connectors | 4.3 | Clause 4 |
| 2.2 | Electrostatic phenomena | | 4.3 | |
| 3 | Thermal hazards, resulting in: | | | |
| 3.1 | Burns and other injuries by a possible contact of persons with objects or materials with an extreme high-temperature, by flames or explosions and also by the radiation of heat sources. | Gas generating system Flame curtain Environment of the TPE | 4.4.1, 4.4.4 | |
| 3.2 | Damage to health by hot working environment | Environment of the TPE | 4.4.5 | |
| 4 | Hazards caused by interruption of energy supply | | | |
| 4.1 | Malfunction or break up of components | Gas generating and distribution system | 4.3, 4.11.1 | 4.3.1.2.5 |
| 4.2 | Malfunction or break down of control system | Control system | 4.3, 4.11.1 | |
| 5 | Hazards caused by (temporary) missing and/or incorrectly positioned safety related measures/means | | | |
| 5.1 | Specific hazard of maintenance and adjusting | Piping, duct, control system | 4.12 | |
| 6 | Hazards generated by materials and substances processed or used by the machinery | | | |
| 6.1 | Hazards from contact with or inhalation of harmful fluids, gases, mists, fumes, and dusts. | Gas generating, distribution system, exhaust gases and TPE | 4.8.2 | Clauses 4 and 5 |

Table A.1 (continued)

| Clause | Hazards | Location | Relevant clauses of ISO 13577-1:2012 | Relevant clauses of this part of ISO 13577 |
|----------|---|--|--------------------------------------|---|
| 6.2 | Fire or explosion hazard | Gas generating, distribution system, exhaust gases and TPE | 4.4.3, 4.8.3 | Clauses 4 and 5 |
| 7 | Hazards generated by neglecting ergonomic principles in machinery design, as hazards from: | | | |
| 7.1 | Hazard of mismatch of design, location or identification of manual controls | Pipework control system | 4.9 | |

Annex B (informative)

Typical protective and reactive atmosphere gases

Typically, any gas mixture containing more than a volume fraction of 5 % combustibles ($H_2+CO+CH_4$), of which CH_4 is not more than a volume fraction of 1 %, where the remainder of the mixture is non-combustible, is considered to be combustible. Any gas mixture which contains more than a volume fraction of 1 % C_nH_m or a volume fraction of 2,5 % NH_3 where the remainder of the mixture is non-combustible is also considered to be combustible.

A combustible gas which contains a volume fraction of 1 % or less oxygen cannot in itself form an explosive or combustible mixture.

Table B.1 — Typical protective and reactive atmosphere gases

| Atmosphere gases | | Typical gas composition % (volume fraction) | | | | | Density kg/m ³ | Weight (relative to air) | | Hazards | | |
|-------------------------------------|-------------------|--|------------|----------------|----------------|------------------|------------------------------|--------------------------------|--------------|---------------------|---------------|-------------------|
| | | CO ₂ | CO | H ₂ | N ₂ | H ₂ O | | light- er | heav- ier | exp- lo- sion | tox- icity | asphyxi- ation |
| Elementary gases: | | | | | | | | | | | | |
| 1) Helium | (He) | — | — | — | — | — | 0,179 | x | — | — | — | x |
| 2) Argon | (Ar) | — | — | — | — | — | 1,784 | — | x | — | — | x |
| 3) Nitrogen | (N ₂) | — | — | — | 100 | — | 1,251 | x ^f | — | — | — | x |
| 4) Hydrogen | (H ₂) | — | — | 100 | — | — | 0,090 | x | — | x | — | x |
| Exothermic atmospheres ^c | | | | | | | | | | | | |
| 5) CCHN-type ^a | (‘lean’) | 12 to 18 | 0,5 to 2,5 | 0,5 to 2,5 | 87 to 85 | e | 1,131 ^h | x ^f | — | — ^b | x | x |
| | (‘rich’) | 8 to 4 | 5 to 12 | 5 to 18 | 82 to 66 | e | 1,161 ^h | x | — | x | x | x |
| 6) CHN-type ^a | (‘lean’) | — | 0,5 to 2,5 | 0,5 to 2,5 | 99 to 95 | — | 1,234 ^h | x ^f | — | — ^b | x | x |
| | (‘rich’) | — | 5 to 12 | 5 to 18 | 90 to 70 | — | 1,117 ^h | x | — | x | x | x |
| 7) HN-type ^a | (‘lean’) | — | — | 1 to 5 | 99 to 95 | — | 1,216 ^h | x ^f | — | — ^b | — | x |
| | (‘rich’) | — | — | 10 to 30 | 90 to 70 | — | 1,019 ^h | x | — | x | — | x |
| Endothermic atmospheres: | | | | | | | | | | | | |
| 8) ENDO-Gas | | Traces | 20 to 23 | 31 to 40 | 40 to 46 | Traces | 0,834 ^h | x | — | x | x | x |
| 9) Ammonia (dissociated) | | — | — | 75 | 25 | — | 0,380 | x | — | x | — | x |
| 10) Methanol (dissociated) | | Traces | 33 | 67 | — | Traces | 0,868 | x | — | x | x | x |

Table B.1 (continued)

| Atmosphere gases | | Typical gas composition % (volume fraction) | | | | | Density kg/m ³ | Weight (relative to air) | | Hazards | | |
|---|----------------------------------|--|----|----------------|----------------|------------------|------------------------------|--------------------------------|--------------|---------------------|---------------|-------------------|
| | | CO ₂ | CO | H ₂ | N ₂ | H ₂ O | | light- er | heav- ier | ex- plo- sion | tox- icity | asphyxi- ation |
| Other atmosphere gases: | | | | | | | | | | | | |
| 11) Water vapour | (H ₂ O) | — | — | — | — | 100 | 0,805g | x | — | — | — | x |
| 12) Carbon dioxide | (CO ₂) | 100 | — | — | — | — | 1,977 | — | x | — | — | x |
| 13) Ammonia | (NH ₃) | — | — | — | — | — | 0,771 | x | — | x | x | x |
| 14) Hydrocarbons | | | | | | | | | | | | |
| Methane | (CH ₄) | — | — | — | — | — | 0,717 | x | — | x | — | x |
| Propane | (C ₃ H ₈) | — | — | — | — | — | 2,019 | — | x | x | — | x |
| <p>a Code letters indicate typical constituents: (C) → CO (CC) → CO + CO₂ (H) → H₂ (N) → N₂</p> <p>b Provided that (CO + H₂ + max. a volume fraction of 1 % CH₄) ≤ a volume fraction of 5 %.</p> <p>c Protective and reactive atmosphere gases classified under 5 to 10 can also be produced by mixing of component gases.</p> <p>d The percentage of combustibles in a furnace chamber can be higher due to the addition of hydrocarbons or the vapourization of oily residues of insufficiently cleaned work pieces.</p> <p>e The amount of water vapour may be varied to make the atmosphere gas suitable for specific processes.</p> <p>f Difference in density relative to air is only slight. Equal density should be assumed in terms of safety considerations.</p> <p>g Gaseous state not existing under physical "Standard Conditions" (0 °C/1 013 mbar = 1, 013 × 10⁵ Pa).</p> <p>h Density value refers to mean composition.</p> | | | | | | | | | | | | |

Annex C (normative)

Allowed maximum pressure

This annex covers the pressure hazard of piping forming an integral part of combustion and fuel handling systems of TPE intended to be subjected to an allowed maximum pressure not exceeding 50 kPa, containing

NOTE References to Group 2 and Group 3 of this annex are mentioned for information only.

- a) gases, liquefied gases, gases dissolved under pressure, vapours and also those liquids whose vapour pressure at the allowed maximum temperature exceeding 50 kPa above normal atmospheric pressure, (101,3 kPa) at the following limits:
- for Group 1
 - DN 25 and included;
 - $DN \times PS \text{ (kPa)} = 1,0 \times 10^5 \text{ kPa}$ for DN 25 up to 100 and included (see [Figure C.1](#));
 - for Group 2
 - DN 100 and included;
 - $DN \times PS \text{ (kPa)} = 3,5 \times 10^5 \text{ kPa}$ for DN greater than 100 (see [Figure C.2](#));
- b) liquids having a vapour pressure at the allowed maximum temperature not exceeding 50 kPa above normal atmospheric pressure (101,3 kPa) at the following limits:
- for Group 1
 - DN 25 and included;
 - $DN \times PS \text{ (kPa)} = 2,0 \times 10^5 \text{ kPa}$ for DN 25 up to 200 and included;
 - $PS = 1,0 \times 10^3 \text{ kPa}$ for DN greater than 200 (see [Figure C.3](#));
 - for Group 2
 - DN 200 and included;
 - $PS = 50 \times 10^3 \text{ kPa}$ for DN greater than 200 (see [Figure C.4](#)).

Group 1 comprises the following fluids:

- explosive;
- extremely combustible:
 - highly combustible;
 - combustible (where the maximum allowable temperature is above flashpoint);
 - very toxic;
 - toxic;
 - oxidizing.

Group 2 comprises all other fluids.

This annex is not applicable to piping forming an integral part of combustion and fuel handling systems of industrial thermo processing equipment intended to contain unstable gases.

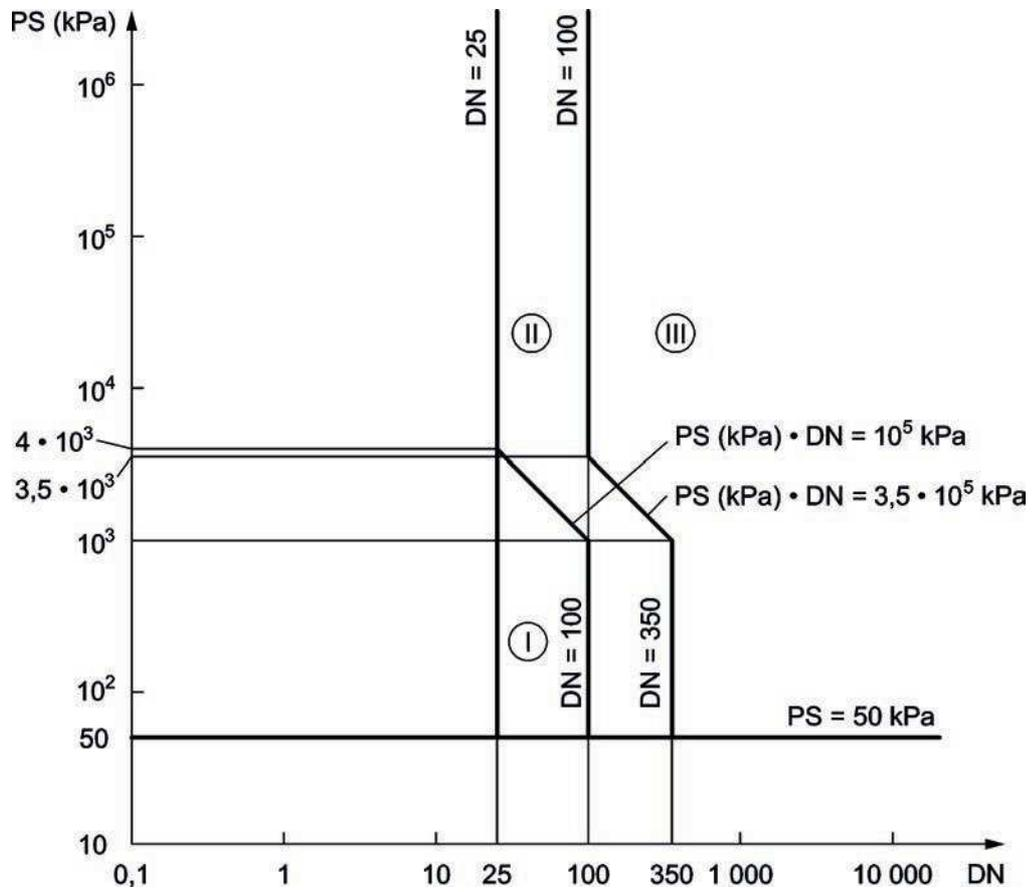

Figure C.1 — Piping referred to in a) Group 1 of this annex

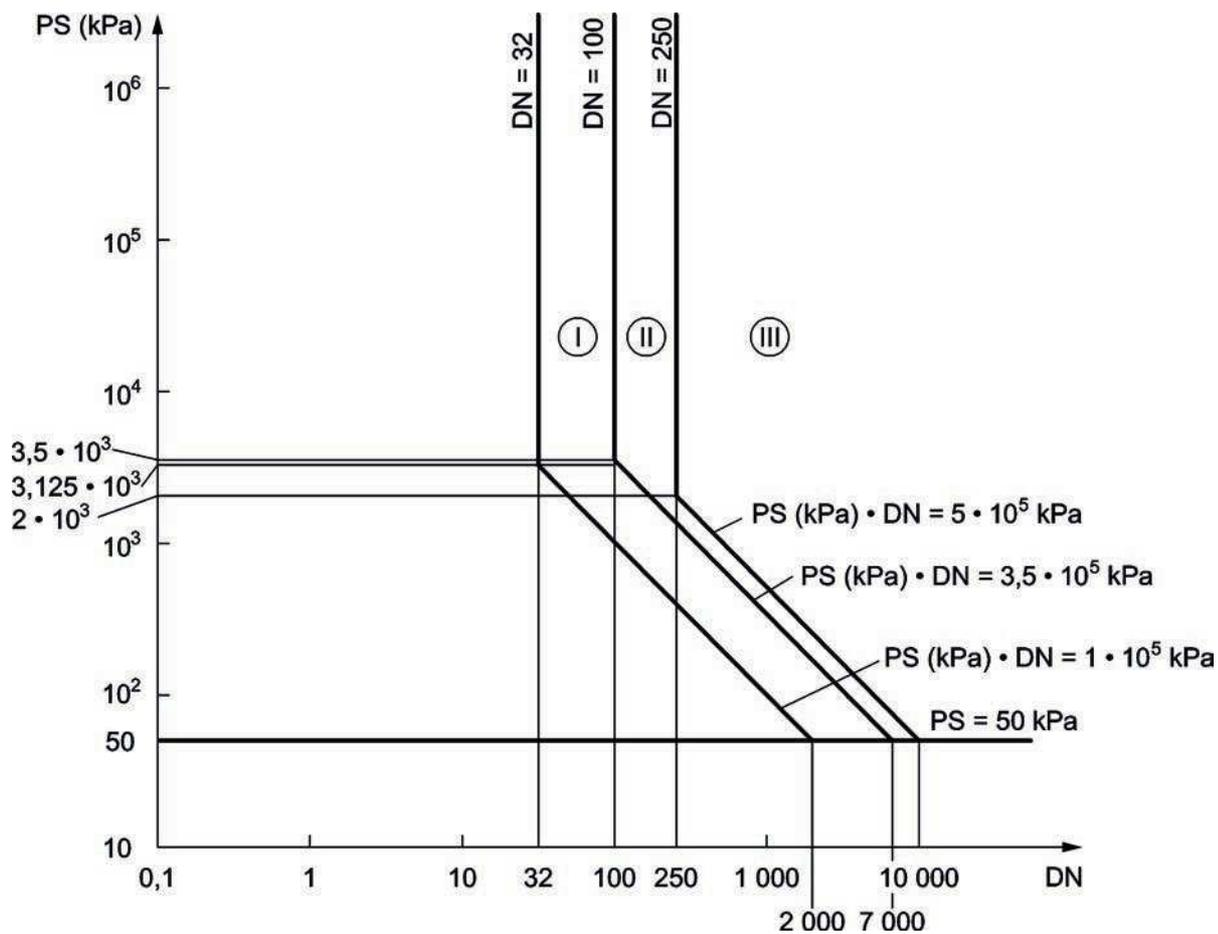

Figure C.2 — Piping referred to in a) Group 2 of this annex

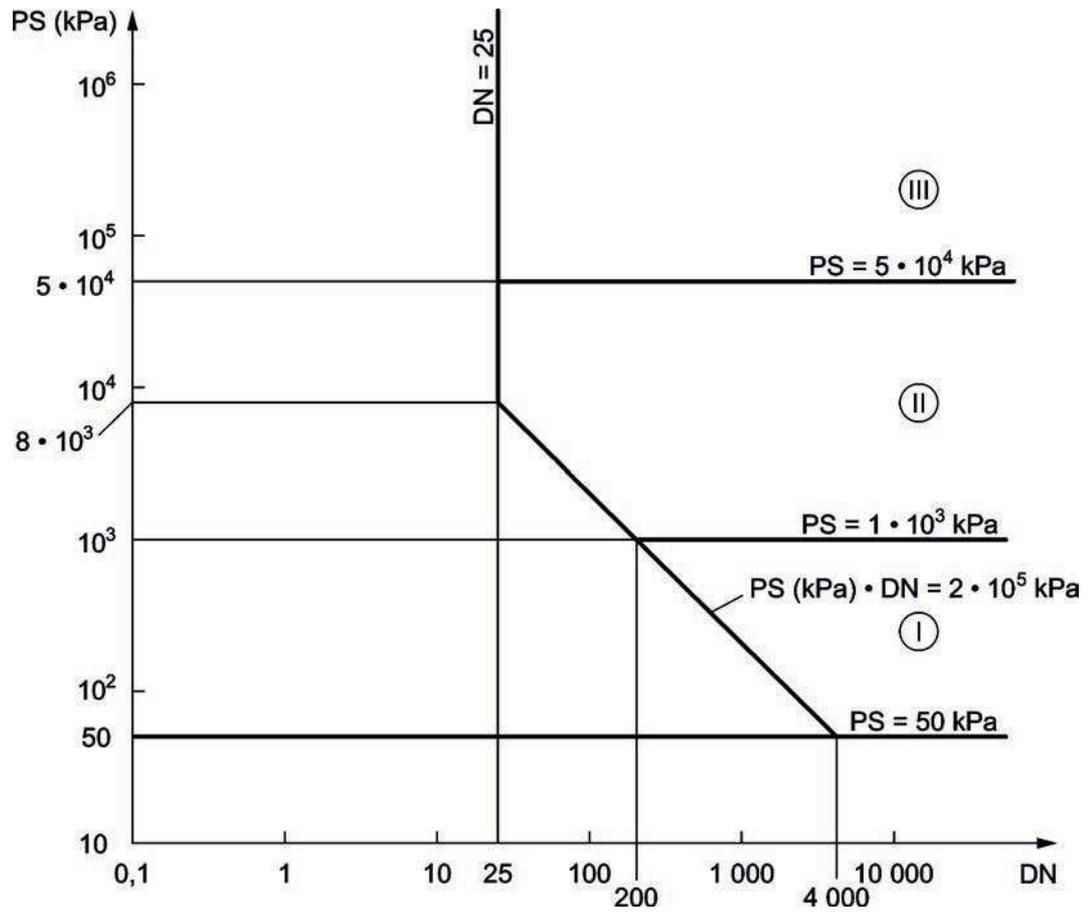

Figure C.3 — Piping referred to in b) Group 1 of this annex

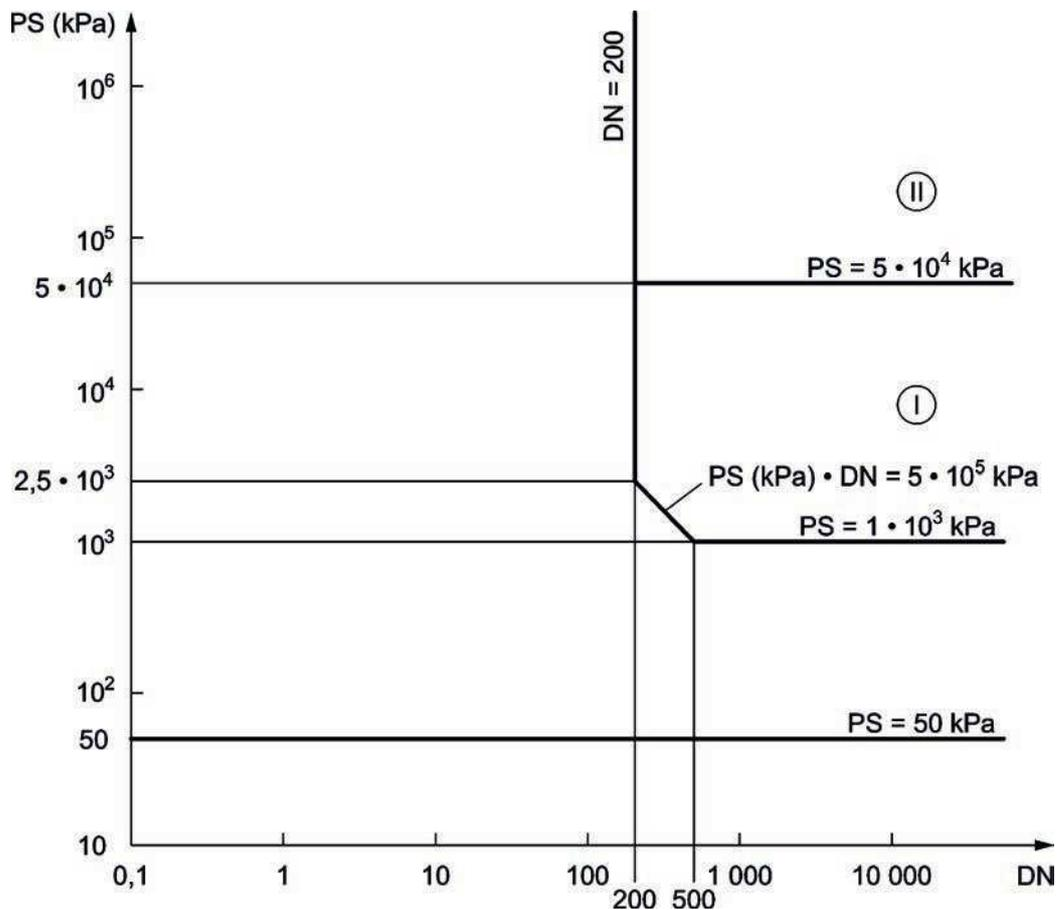

Figure C.4 — Piping referred to in b) Group 2 of this annex

Annex D (informative)

Principle procedures for the change of atmosphere

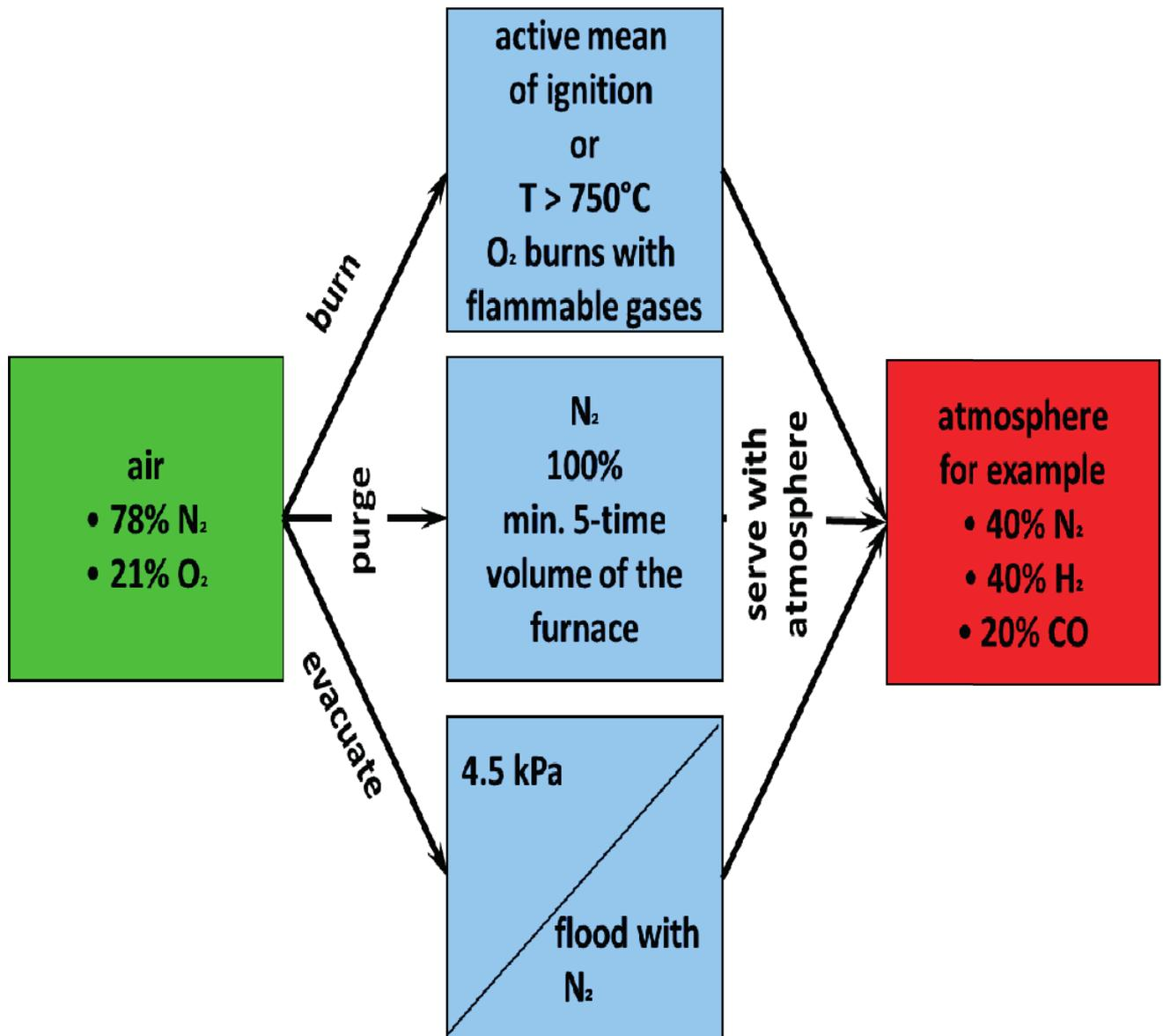

Figure D.1 — Principle procedures for the change of atmosphere

Annex E (informative)

Examples for the determination of safety integrity level SIL and performance level PL using the risk graph method

Several International Standards may be used for determination of the required safety integrity level (SIL)/performance level (PL). For machinery, IEC 62061 was developed to determine the SIL, while IEC 61511 (all parts) was developed to determine the required SIL for process industry. Risk graph methods for determining the SIL are given in both IEC standards. In addition, ISO 13849-1 covers the determination of a performance level PL and also includes a method to determine PL from SIL (ISO 13849-1:2006, Table 4).

[Table E.1](#) shows an example of SIL/PL determination according to IEC 62061-1 or ISO 13849:2006, Table 4. This SIL determination is done according to IEC 62061:2005, Figure A.3. The PL is determined in accordance with Table 4 in ISO 13849-1:2006 which shows the relationship between PL and SIL.

[Table E.2](#) shows an example with a PL determination according to ISO 13849-1:2006, Annex A with an additional column where the corresponding SIL values determined according to ISO 13849-1:2006, Table 4 are given.

The values given in [Table E.1](#) and [Table E.2](#) refer to typical TPE. The required SIL/PL levels might vary dependent on the individual risk assessment.

Table E.1 — Example of SIL determination according to IEC 62061 for a multi-chamber furnace at an inside temperature >750 °C

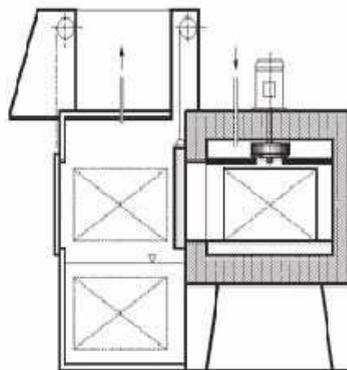

Risk assessment and safety measures

Document No.:

Part of:

Project: Example of typical SIL determination

Issued by: _____

Date: _____

Revision: 2013/04/05

Black area = Safety measures required

Grey area = Safety measures recommended

- Pre-risk assessment
- Intermediate risk assessment
- Follow-up risk assessment

| Consequences | Severity Se | Class Cl | | | | | Frequency and duration, Fr | | Probability of hazard. event, Pr | | Avoidance Av | |
|-------------------------------|----------------|----------|-------|-------|-------|-------|----------------------------|---|----------------------------------|---|-----------------|---|
| | | 3-4 | 5-7 | 8-10 | 11-13 | 14-15 | | | | | | |
| Death, losing an eye or arm | 4 | SIL 2 | SIL 2 | SIL 2 | SIL 3 | SIL 3 | ≤1 h | 5 | Very high | 5 | | |
| Permanent, losing fingers | 3 | | OM | SIL 1 | SIL 2 | SIL 3 | >1 h to ≤1 d | 5 | Likely | 4 | | |
| Reversible, medical attention | 2 | | | OM | SIL 1 | SIL 2 | >1 d to ≤2 wks | 4 | Possible | 3 | Impossible | 5 |
| Reversible, first aid | 1 | | | | OM | SIL 1 | >2 wks to ≤1 yr | 3 | Rarely | 2 | Possible | 3 |
| | | | | | | | >1 yr | 2 | Negligible | 1 | Likely | 1 |

Table E.1 (continued)

| SRCF No. | Hazardous event Description | Safety Related Control Function (SRCF) Description | Consequences | | Probability of occurrence | | | | Class | Integrity | | Comments |
|------------|--|--|--------------|----|---------------------------|----|----|----|-------|-----------|--|----------|
| | | | | Se | Fr | Pr | Av | Cl | SIL | PL | | |
| 01a | Failure of gas pressure regulator Non-flammable gas | An automatic shut-off valve downstream the gas pressure regulator is closed to avoid pressure above the design pressure. | | 3 | 4 | 2 | 5 | 11 | 2 | PL d | ISO 13577-3:2016, 4.3.1.2.3 Pressure regulator and over pressure protection Hazards: Burst of devices/instrumentation downstream Condition: — the safety nitrogen is taken from before the pressure regulator | |
| 01b | Failure of gas pressure regulator Non-flammable gas | An automatic shut-off valve downstream the gas pressure regulator is closed to avoid pressure above the design pressure. | | 0 | | | | | | | ISO 13577-3:2016, 4.3.1.2.3 Pressure regulator and over pressure protection Hazards: Burst of devices/instrumentation downstream Condition: — the safety nitrogen is taken from before the pressure regulator — devices/instrumentation behind a protective shield No SRCF is needed in this case | |
| 01c | Failure of gas pressure regulator Flammable gas | An automatic shut-off valve downstream the gas pressure regulator is closed to avoid pressure above the design pressure. | | 4 | 4 | 2 | 5 | 11 | 3 | PL e | ISO 13577-3:2016, 4.3.1.2.3 Pressure regulator and over pressure protection Hazards: — Burst of devices/instrumentation downstream — forming of an explosive atmosphere after the burst of devices/instrumentation | |

Table E.1 (continued)

| SRCF No. | Hazardous event Description | Safety Related Control Function (SRCF) Description | Consequences | | Probability of occurrence | | | | Class | Integrity | | Comments |
|----------|--|---|---|----|---------------------------|----|----|----|-------|-----------|--|----------|
| | | | | Se | Fr | Pr | Av | Cl | SIL | PL | | |
| 02a | Failure of temperature monitoring for self-ignition The furnace is always supervised by an operator | The supply of flammable atmosphere gas to TPE is allowed only when the temperature in the TPE is above 750 °C. | | 4 | 4 | 2 | 1 | 7 | 2 | PL d | 4.4.1.2 Safety temperature Hazards: Explosion and/or fire caused by mixed flammable atmosphere gas and air Condition: The furnace is always supervised by an operator | |
| 02b | Failure of temperature monitoring for self-ignition The furnace is not always supervised by an operator | The supply of flammable atmosphere gas to TPE is allowed only when the temperature in the TPE is above 750 °C. | | 4 | 4 | 2 | 3 | 9 | 2 | PL d | 4.4.1.2 Safety temperature Hazards: Explosion and/or fire caused by mixed flammable atmosphere gas and air Condition: The furnace is not always supervised by an operator | |
| 03 | Pressure in TPE falls below the required minimum pressure | The supply of flammable atmosphere gas to TPE is allowed only when the pressure in the TPE stays above the required minimum pressure. | | 4 | 4 | 3 | 4 | 11 | 3 | PL e | 4.4.1.3 Monitoring of TPE pressure operating under 750 °C Hazards: Explosion and/or fire caused by mixed flammable atmosphere gas and air Condition: A part of the furnace operates below 750 °C | |
| 04 | Oxygen level in the TPE rises above a predetermined limit | The supply of flammable atmosphere gas to TPE is allowed only when the oxygen level in the TPE stays below a predetermined limit. | This SRCF does not apply to the furnace in the example; no oxygen is added to the furnace together with flammable gases. | | | | | | | | 4.4.1.4 Controlling process air/oxygen of TPE operating below 750 °C Hazards: Explosion and/or fire caused by mixed flammable atmosphere gas and air | |
| 05 | Flow rate of atmosphere gas falls below the minimum rate | The supply of flammable atmosphere gas to TPE is allowed only when the flow rate of the atmosphere gas stays above the required minimum rate. | This SRCF does not apply to the furnace in the example; the pressure in TPE is monitored according to 4.4.1.3. | | | | | | | | 4.4.1.5 Monitoring of atmosphere gas and process liquid supply Hazards: Explosion and/or fire caused by mixed flammable atmosphere gas and air | |

Table E.1 (continued)

| SRCF No. | Hazardous event Description | Safety Related Control Function (SRCF) Description | Consequences | | Probability of occurrence | | | | Class | Integrity | | Comments |
|----------|--|---|--|----|---------------------------|----|----|----|-------|-----------|--|---|
| | | | | Se | Fr | Pr | Av | Cl | SIL | PL | | |
| 06 | Failure of means of ignition at doors or access openings | Doors or access openings shall only open, if a mean of ignition is active. | | 3 | 4 | 3 | 3 | 10 | 1 | Pl c | <p>4.4.2 Monitoring of TPE doors movements</p> <p>Hazards: Explosion and/or fire caused by mixed flammable atmosphere gas and air</p> | |
| 7 | Failure of means of ignition at the point of flammable gas discharge | The supply of flammable atmosphere gas to TPE is started only when the mean of ignition is in good order. A failure creates an alarm. | | 3 | 4 | 2 | 3 | 9 | 1 | Pl c | <p>4.4.3 Supervision of the means of ignition at the point of combustible atmosphere gas discharge</p> <p>Hazards: Explosion and/or fire caused by mixed combustible atmosphere gas and air</p> <p>Condition: mean of ignition is an ignition burner</p> | |
| 8 | Failure of emergency purge | An emergency purge for the TPE in upset conditions has always to be possible. | | | | | | | | | <p>4.4.4 Emergency safety purge</p> <p>Hazards: Explosion and/or fire caused by mixed combustible atmosphere gas and air</p> | |
| 9 | Failure in change of atmosphere in the TPE | The inert gas purge is continued until all the air has been displaced. | This SRCF does not apply to the furnace in the example; the change of atmosphere is done by another purging method. | | | | | | | | | <p>4.5.2.2 Purge with inert gas to change atmosphere from air to combustible gas</p> <p>Hazards: Explosion and/or fire caused by mixed combustible atmosphere gas and air</p> |
| 10 | Failure in change of atmosphere in the TPE | The inert gas purge is continued until all the flammable atmosphere gas has been displaced. | This SRCF does not apply to the furnace in the example; the change of atmosphere is done by another purging method. | | | | | | | | | <p>4.5.2.3 Purge with purge gas to change atmosphere from combustible gas to air</p> <p>Hazards: Explosion and/or fire caused by mixed combustible atmosphere gas and air</p> |

Table E.1 (continued)

| SRCF No. | Hazardous event Description | Safety Related Control Function (SRCF) Description | Consequences | | Probability of occurrence | | | | Class | Integrity | | Comments |
|----------|--|--|--|----|---------------------------|----|----|-----|-------|-----------|--|--|
| | | | Se | Fr | Pr | Av | Cl | SIL | PL | | | |
| 11 | Failure in change of atmosphere in the TPE | A mean of ignition burns the admitted flammable atmosphere gas until no oxygen in TPE is left. | | 4 | 4 | 3 | 5 | 12 | 1 | Pl c | <p>4.5.4.2 Change of atmosphere by burning from air to combustible gas</p> <p>Hazards: Explosion and/or fire caused by mixed combustible atmosphere gas and air</p> <p>State of the art is currently max SIL 1</p> | |
| 12 | Failure in change of atmosphere in the TPE | Evacuation of air in the TPE to a pressure of 4,5 kPa absolute and subsequent flooding with inert gas. | This SRCF does not apply to the furnace in the example; the change of atmosphere is done by another purging method. | | | | | | | | | <p>4.5.5.2 Purge by evacuation to change atmosphere from air to combustible gas</p> <p>Hazards: Explosion and/or fire caused by mixed combustible atmosphere gas and air</p> |
| 13 | Failure in change of atmosphere in the TPE | Evacuation of flammable gas in the TPE to a safe pressure and subsequent flooding with inert gas. | This SRCF does not apply to the furnace in the example; the change of atmosphere is done by another purging method. | | | | | | | | | <p>4.5.5.3 Purge by evacuation to change atmosphere from combustible gas to air</p> <p>Hazards: Explosion and/or fire caused by mixed combustible atmosphere gas and air</p> |
| 14 | Failure of the temperature control of the endothermic atmosphere generator | Monitoring of the operating temperature of the endothermic atmosphere generator. | This SRCF does not apply to the furnace in the example. | | | | | | | | | 5.5.1.4 Temperature monitoring |

Table E.2 — Example of PL determination according to ISO 13849-1 for a multi-chamber furnace at an inside temperature >750 °C

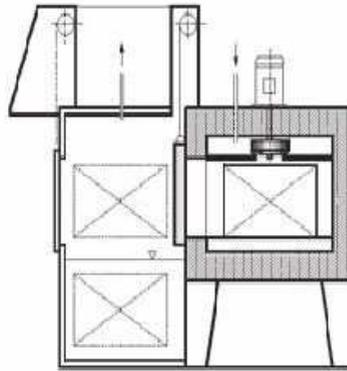

| | | |
|--|----|--|
| | S | Seriousness of injury |
| | S1 | Minor (usually reversible) injury |
| | S2 | Serious (usually irreversible injury including death) |
| | Fr | Frequency and/or duration of the exposure to the hazard |
| | F1 | Seldom to not very frequent and/or exposure to hazard is brief |
| | F2 | Frequent to continuous and/or exposure to hazard is long |
| | P | Possibility of preventing the hazard or limiting the harm |
| | P1 | Possible under certain conditions |
| | P2 | Almost unavoidable |

Table E.2 (continued)

| SRCF No. | Hazardous event Description | Safety Related Control Function (SRCF) Description | S | Fr | P | Integrity | | Comments |
|----------|--|--|----|----|----|-----------|-----|---|
| | | | | | | PL | SIL | |
| 01a | Failure of gas pressure regulator Non-flammable gas | An automatic shut-off valve downstream the gas pressure regulator is closed to avoid pressure above the design pressure. | S2 | F1 | P2 | d | 2 | ISO 13577-3:2016, 4.3.1.2.3 Pressure regulator and over pressure protection Hazards: Burst of devices/ instrumentation downstream Condition: — the safety nitrogen is taken from before the pressure regulator |
| 01b | Failure of gas pressure regulator Non-flammable gas | An automatic shut-off valve downstream the gas pressure regulator is closed to avoid pressure above the design pressure. | 0 | | | | | ISO 13577-3:2016, 4.3.1.2.3 Pressure regulator and over pressure protection Hazards: Burst of devices/ instrumentation downstream Condition: — the safety nitrogen is taken from before the pressure regulator — devices/instrumentation behind a protective shield No SRCF is needed in this case |
| 01c | Failure of gas pressure regulator Flammable gas | An automatic shut-off valve downstream the gas pressure regulator is closed to avoid pressure above the design pressure. | S2 | F1 | P2 | d | 2 | ISO 13577-3:2016, 4.3.1.2.3 Pressure regulator and over pressure protection Hazards: — Burst of devices/ instrumentation downstream — forming of an explosive atmosphere after the burst of devices/instrumentation |

Table E.2 (continued)

| SRCF No. | Hazardous event Description | Safety Related Control Function (SRCF) Description | S | Fr | P | Integrity | | Comments |
|----------|--|---|---|----|----|-----------|---|--|
| | | | | | | PL | SIL | |
| 02a | Failure of temperature monitoring for self-ignition The furnace is always supervised by an operator | The supply of flammable atmosphere gas to TPE is allowed only when the temperature in the TPE is above 750 °C. | S2 | F1 | P1 | c | 1 | 4.4.1.2 Safety temperature Hazards: Explosion and/or fire caused by mixed combustible atmosphere gas and air Condition: The furnace is always supervised by an operator |
| 02b | Failure of temperature monitoring for self-ignition The furnace is not always supervised by an operator | The supply of flammable atmosphere gas to TPE is allowed only when the temperature in the TPE is above 750 °C. | S2 | F1 | P2 | d | 2 | 4.4.1.2 Safety temperature Hazards: Explosion and/or fire caused by mixed combustible atmosphere gas and air Condition: The furnace is not always supervised by an operator |
| 03 | Pressure in TPE falls below the required minimum pressure | The supply of flammable atmosphere gas to TPE is allowed only when the pressure in the TPE stays above the required minimum pressure. | S2 | F1 | P2 | d | 2 | 4.4.1.3 Monitoring of TPE pressure operating under 750 °C Hazards: Explosion and/or fire caused by mixed combustible atmosphere gas and air Condition: A part of the furnace operates below 750 °C |
| 04 | Oxygen level in the TPE rises above a predetermined limit | The supply of flammable atmosphere gas to TPE is allowed only when the oxygen level in the TPE stays below a predetermined limit. | This SRCF does not apply to the furnace in the example; no oxygen is added to the furnace together with flammable gases. | | | | 4.4.1.4 Controlling process air/oxygen of TPE operating under 750 °C Hazards: Explosion and/or fire caused by mixed combustible atmosphere gas and air | |
| 05 | Flow rate of atmosphere gas falls below the minimum rate | The supply of flammable atmosphere gas to TPE is allowed only when the flow rate of the atmosphere gas stays above the required minimum rate. | This SRCF does not apply to the furnace in the example; the pressure in TPE is monitored according to 4.4.1.3. | | | | 4.4.1.5 Monitoring of atmosphere gas and process liquid supply Hazards: Explosion and/or fire caused by mixed combustible atmosphere gas and air | |

Table E.2 (continued)

| SRCF No. | Hazardous event Description | Safety Related Control Function (SRCF) Description | S | Fr | P | Integrity | | Comments |
|----------|--|---|--|----|----|-----------|-----|---|
| | | | | | | PL | SIL | |
| 06 | Failure of means of ignition at doors or access openings | Doors or access openings shall only open, if a mean of ignition is active. | S2 | F2 | P2 | d | 2 | 4.4.2 Monitoring of TPE doors movements Hazards: Explosion and/or fire caused by mixed combustible atmosphere gas and air State of the art is currently max. Pl d |
| 7 | Failure of means of ignition at the point of flammable gas discharge | The supply of flammable atmosphere gas to TPE is started only when the mean of ignition is in good order. A failure creates an alarm. | S2 | F1 | P1 | c | 1 | 4.4.3 Supervision of the means of ignition at the point of combustible atmosphere gas discharge Hazards: Explosion and/or fire caused by mixed combustible atmosphere gas and air Condition: mean of ignition is an ignition burner |
| 8 | Failure of emergency purge | An emergency purge for the TPE in upset conditions has always to be possible. | | | | | | 4.4.4 Emergency safety purge Hazards: Explosion and/or fire caused by mixed combustible atmosphere gas and air |
| 9 | Failure in change of atmosphere in the TPE | The inert gas purge is continued until all the air has been displaced. | This SRCF does not apply to the furnace in the example; the change of atmosphere is done by another purging method. | | | | | 4.5.2.2 Purge with inert gas to change atmosphere from air to combustible gas Hazards: Explosion and/or fire caused by mixed combustible atmosphere gas and air |
| 10 | Failure in change of atmosphere in the TPE | The inert gas purge is continued until all the flammable atmosphere gas has been displaced. | This SRCF does not apply to the furnace in the example; the change of atmosphere is done by another purging method. | | | | | 4.5.2.3 Purge with inert gas to change atmosphere from combustible gas to air Hazards: Explosion and/or fire caused by mixed combustible atmosphere gas and air |

Table E.2 (continued)

| SRCF No. | Hazardous event Description | Safety Related Control Function (SRCF) Description | S | Fr | P | Integrity | | Comments | |
|----------|--|--|--|----|----|-----------|-----|---|---|
| | | | | | | PL | SIL | | |
| 11 | Failure in change of atmosphere in the TPE | A mean of ignition burns the admitted flammable atmosphere gas until no oxygen in TPE is left. | S2 | F1 | P2 | c | 1 | 4.5.4.2 Change of atmosphere by burning from air to combustible gas Hazards: Explosion and/or fire caused by mixed combustible atmosphere gas and air State of the art is currently max. Pl c | |
| 12 | Failure in change of atmosphere in the TPE | Evacuation of air in the TPE to a pressure of 4,5 kPa absolute and subsequent flooding with inert gas. | This SRCF does not apply to the furnace in the example; the change of atmosphere is done by another purging method. | | | | | | 4.5.5.2 Purge by evacuation to change atmosphere from air to combustible gas Hazards: Explosion and/or fire caused by mixed combustible atmosphere gas and air |
| 13 | Failure in change of atmosphere in the TPE | Evacuation of flammable gas in the TPE to a safe pressure and subsequent flooding with inert gas. | This SRCF does not apply to the furnace in the example; the change of atmosphere is done by another purging method. | | | | | | 4.5.5.3 Purge by evacuation to change atmosphere from combustible gas to air Hazards: Explosion and/or fire caused by mixed combustible atmosphere gas and air |
| 14 | Failure of the temperature control of the endothermic atmosphere generator | Monitoring of the operating temperature of the endothermic atmosphere generator. | This SRCF does not apply to the furnace in the example. | | | | | | 5.5.1.4 Temperature monitoring |

Annex F (informative)

Basic configuration of piping system of TPE using protective or reactive atmosphere gases

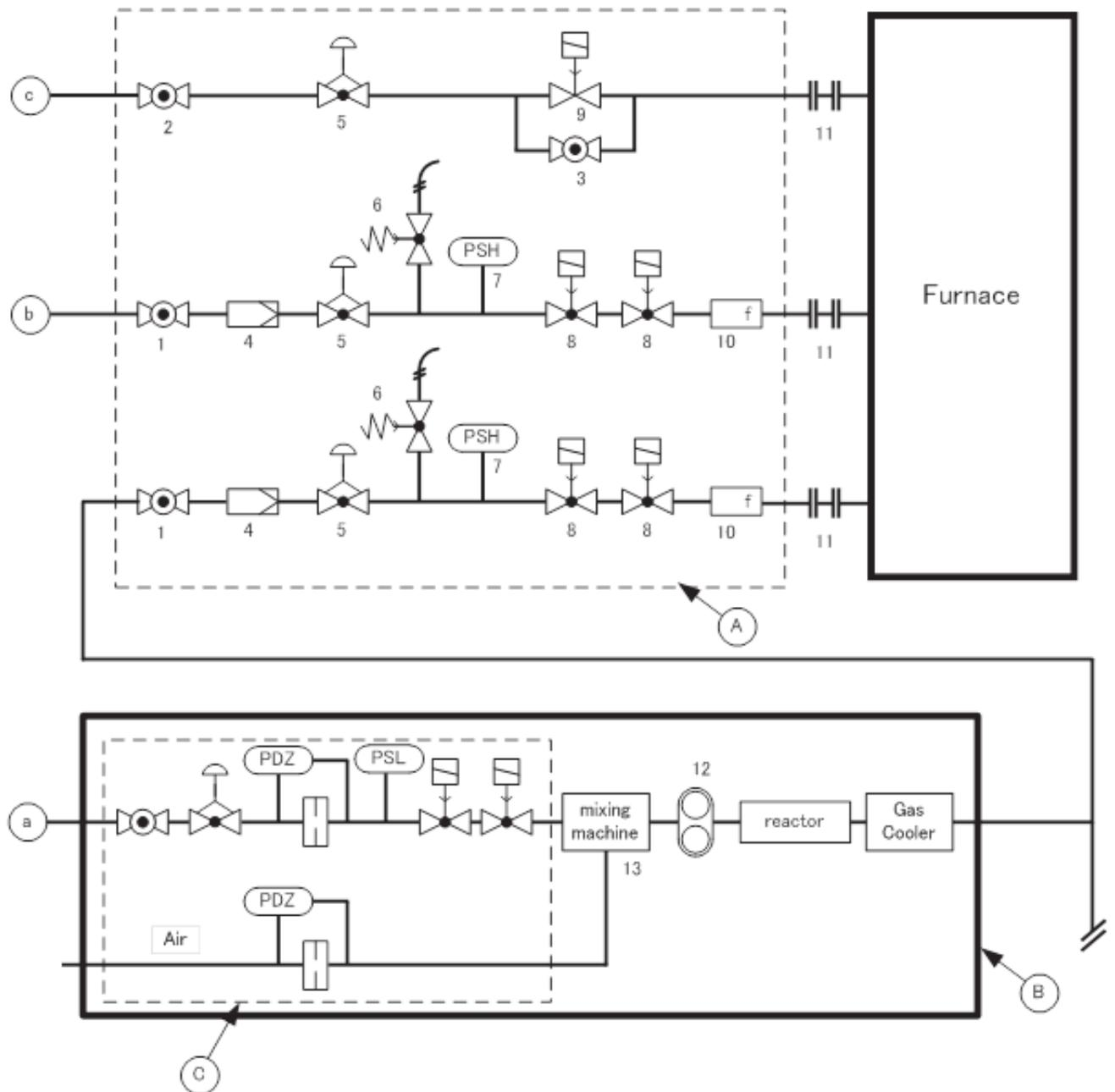

ISO 13577-3:2016(E)

Key

| No. | Description | Relevant clause |
|-----|--|---|
| 1 | manual isolating valve | 4.3.1.2.1 |
| 2 | manual isolating valve (for purge gas supply) | 4.3.1.3 |
| 3 | manual isolating valve (for purge gas by-pass) | 4.3.1.3 |
| 4 | filter/strainer | 4.3.1.2.2 |
| 5 | pressure regulator | 4.3.1.2.3 |
| 6 | pressure relief | 4.3.1.2.4 |
| 7 | overpressure switch | 4.3.1.2.3 |
| 8 | automatic shut-off valve (normally close) | 4.3.1.2.5 |
| 9 | automatic shut-off valve (normally open) | 4.3.1.3 |
| 10 | flow rate indicator (flow meter) | 4.3.1.2.6 |
| 11 | device for safe isolation of atmosphere fluids | 4.2.1 |
| 12 | gas booster/compressor | 4.3.2.2 |
| 13 | mixing machine | 5.5.1.3 , 5.5.1.2 |
| a | fuel gas supply for gas generator | |
| b | other atmosphere gas supply | |
| c | inert gas supply | 4.4.4 |
| A | gas control equipment | 4.3.1 |
| B | gas generator | Clause 5 |
| C | fuel supply system within gas generator | ISO 13577-2 |

Figure F.1 — Basic configuration of piping system of TPE using protective or reactive atmosphere gases

Annex G (normative)

Requirements specific to Japan

G.1 General

Only those provisions of this part of ISO 13577 that are affected by requirements specific to Japan have been identified in this annex, numbered correspondingly to the respective subclauses in the main body of this part of ISO 13577.

The requirements of this annex shall ensure a level of safety at least equivalent to that provided by the requirements in the main body of this part of ISO 13577.

G.2 Background

In addition to the safety requirements specified in this part of ISO 13577, at least information in regard to the following laws and regulations are required to be prepared when combustion and fuel handling systems which this standard covers are to be designed, manufactured and commissioned:

- Industrial Safety and Health Law;
- High Pressure Gas Safety Law;
- Air Pollution Control Act.

For this reason, in addition to the requirements specified in this part of ISO 13577, matters concerning

- NO_x and CO shall comply with the Air Pollution Control Act,
- fuel supplied at 1 MPa or more shall comply with the High Pressure Gas Safety Act, and
- general safety, which is not covered by this part of ISO 13577, shall comply with the relevant regulations specified in the Industrial Safety and Health Act.

In addition, regional safety requirements for combustion and fuel handling systems of TPE used in Japan are specified in JIS B 8415:2008.

Those specified in this clause are the additional requirements or test methods based on JIS B 8415:2008 for equipment intended to be used in Japan.

G.3 References

For dated references only, the edition cited applies. For undated references, the latest edition of the referenced document (including any amendments) applies.

JIS B 2220, *Steel pipe flanges*

JIS B 2312, *Steel butt-welding pipe fittings*

JIS G 3452, *Carbon steel pipes for ordinary piping*

JIS G 3454, *Carbon steel pipes for pressure service*

JIS G 3455, *Carbon steel pipes for high pressure service*

ISO 13577-3:2016(E)

JIS G 3456, *Carbon steel pipes for high temperature service*

JIS G 3457, *Arc welded carbon steel pipes*

JIS G 3458, *Alloy steel pipes*

JIS G 3459, *Stainless steel pipes*

JIS G 3460, *Steel pipes for low temperature service*

JIS G 3461, *Carbon steel boiler and heat exchanger tubes*

JIS G 3462, *Alloy steel boiler and heat exchanger tubes*

JIS G 3463, *Stainless steel boiler and heat exchanger tubes*

JIS H 3300, *Copper and copper alloy seamless pipes and tubes*

JIS H 3401, *Pipe fittings of copper and copper alloys*

JIS K 6774, *Polyethylene pipes for the supply of gaseous fuels*

JIS B 8415, *General Safety Code for Industrial Combustion Furnaces*

G.4 Requirements

G.4.1 Resistance heating

Additional to [Clause 4](#)

Resistance heating furnace shall be in accordance with JIS B 8420, if applicable.

G.4.2 Pipework, General

Additional to [4.2.1](#)

Fuel gas pipes shall be as specified in JIS G 3452; JIS G 3454; JIS G 3455; JIS G 3456; JIS G 3457; JIS G 3458; JIS G 3459; JIS G 3460; JIS G 3461; JIS G 3462; JIS G 3463; JIS K 6774; and JIS H 3300, as applicable.

However, pipes to JIS G 3458 shall be used only for buried portions of the piping under pressures of less than 1,6 MPa; those to JIS G 3452, only for buried portions under pressures of less than 1,0 MPa; those to JIS K 6774, only for buried portions under pressures of less than 0,3 MPa; and those to JIS H 3300, only exposed portions under pressures of less than 0,1 MPa.

Any flexible tubes not specified in this clause may be used only if they withstand the maximum operating pressure and temperature involved.

G.4.2.1 Connections

Additional to [4.2.2](#)

Any steel pipes with a nominal diameter of not more than 20A for use under a maximum operating pressure of not more than 0,1 MPa may be connected using compression fittings.

Any copper or copper alloy seamless pipes shall be connected in accordance with JIS H 3401, and such seamless pipes with a nominal diameter of 20A or less for use under a pressure of 0,01 MPa or less may be connected using flared or compression fittings. Brass and copper alloy shall not be used for piping, which contact with ammonia or dissociated ammonia.

Annex H (normative)

Requirements specific to the U.S.A.

H.1 General

Only those subclauses in this part of ISO 13577 that are affected by requirements specific to the U.S.A. have been identified in this annex, numbered correspondingly to the respective subclauses in the main body of this part of ISO 13577.

The requirements of this annex shall ensure a level of safety at least equivalent to that provided by the requirements in the main body of this part of ISO 13577.

H.2 Background

For equipment intended to be used in the U.S., the “Authority Having Jurisdiction” (AHJ) has the ultimate authority to approve the overall system installation of the equipment. The AHJ may be a State Government, local Fire Marshall, local building inspector, local board or commission, the user’s insurance underwriter, an engineer or the end user. The US Federal and State Governments have occupational safety and health requirements for a given installation via the Occupation Safety and Health Administration (OSHA), but OSHA does not typically act as the AHJ during the initial installation and commissioning of the equipment.

The OSHA requirements for the U.S. (29 CFR Part 1910 General Industry Standards) can be downloaded at <http://www.osha.gov/>. Some common hazards are covered in ISO 13577-1:2012, Clause 4 in the “List of hazards”. However, complying with these may not be enough to satisfy the OSHA requirements in the USA for a given installation. Should OSHA determine that an American National Standard would provide a higher level of safety than the International Standard, OSHA could impose the requirements of other American National Standards in addition to the requirements of the International Standard for a given installation.

The end user is responsible for identifying and communicating with the AHJ for a given installation.

For applications covered under this part of ISO 13577, NFPA 86 is the recognized American National Standard in the U.S. The scope of NFPA 86 is limited to hazards associated with fires and explosions. In addition to equipment requirements, it also includes requirements for the end user and the installation location, whereas this part of ISO 13577 only covers requirements for the thermal processing equipment (TPE). Thus, complying with this part of ISO 13577 does not mean that the installation will meet the requirements of NFPA 86 or the AHJ, who might have additional or different requirements than those in this part of ISO 13577. However, since all installations are subject to approval of the AHJ, it is possible for equipment complying with the requirements of this part of ISO 13577 to be accepted.

H.3 Normative references

For the purposes of this annex, the following normative references apply.

ANSI/ASME B1.20.1, *Pipe Threads, General Purpose (inch)*

ANSI/ASME B31.1, *Power Piping*

ANSI/ASME B31.3, *Process Piping*

ANSI/ASME B16.20, *Metallic Flat Gaskets for Pipe Flanges*

ISO 13577-3:2016(E)

ANSI/ASME B16.21, *Non Metallic Flat Gaskets for Pipe Flanges*

International Fuel Gas Code

NFPA 31, *Standard for the Installation of Oil-Burning Equipment*

NFPA 54, *National Fuel Gas Code*

NFPA 55, *Compressed Gases and Cryogenic Fluids Code*

NFPA 70, *National Electrical Code*

NFPA 79, *Electrical Standard for Industrial Machinery*

NFPA 86, *Standard for Ovens and Furnaces*

H.4 Requirements

H.4.1 Electrical installation, General

The electrical installation shall comply with

- NFPA 70, *National Electrical Code*, and
- NFPA 79, *Electrical Standard for Industrial Machinery*.

Where seal leakage or diaphragm failure in a device can result in flammable gas or flammable liquid flow through a conduit or cable to an electrical ignition source, a conduit seal or a cable type that is sealed shall be installed.

H.4.2 Pipework, General

The pipework materials shall comply with

- NFPA 54, *National Fuel Gas Code or International Fuel Gas Code*.

H.4.2.1 Connections

The pipework connections including pressure limitations shall comply with the following, as applicable:

- ANSI/ASME B1.20.1, *Pipe Threads, General Purpose (inch)*;
- ANSI/ASME B31.1, *Power Piping*;
- ANSI/ASME B31.3, *Process Piping*;
- ANSI/ASME B16.20, *Metallic Flat Gaskets for Pipe Flanges*;
- ANSI/ASME B16.21, *Non Metallic Flat Gaskets for Pipe Flanges*.

Annex I (normative)

Requirements specific to European countries

I.1 General

Only those provisions of this part of ISO 13577 that are affected by requirements specific to Europe and associated countries have been identified in this annex, numbered correspondingly to the respective subclauses in the main body of this part of ISO 13577.

The requirements of this annex shall ensure a level of safety at least equivalent to that provided by the requirements in the main body of this part of ISO 13577.

I.2 Background

For TPE intended to be used in the European Economic Community (EEC) member countries, European Free Trade Association (EFTA) member countries accepting European (EEC) legislation, and in all other countries accepting European legislation, it shall be noted that this part of ISO 13577 provides specific essential health and safety requirements of Annex 1 of the applicable Directive the standard is referring to or harmonized under, and only for the products in the scope of this part of ISO 13577.

This means that essential requirements of other European Directives could be applicable.

Examples of potential additional requirements are

- equipment intended to be used in hazardous locations shall additionally comply with EEC-ATEX-requirements,
- equipment used under pressure (vessels, piping) exceeding 50 kPa may additionally need to comply with EEC-PED-requirements, and
- equipment used with voltages between certain limits shall additionally comply with EEC-Low Voltage and EEC-EMC requirements.

It shall be verified in the scope of the European Directives themselves if the Directive is additionally applicable.

Other requirements are not in the clauses of this part of ISO 13577, but are specified in the EEC-Directives themselves. Certification requirements, declaration requirements, literature requirements, language requirements are specified in each Directive. It shall be verified, for each applicable Directive, which additional requirements are applicable, for the TPE before it is installed and commissioned in above specified countries.

I.3 Normative references

For the purposes of this annex, the following normative references apply.

EN 88-1:2011, *Pressure regulators and associated safety devices for gas appliances — Part 1: Pressure regulators for inlet pressures up to and including 50 kPa*

EN 88-2:2008, *Pressure regulators and associated safety devices for gas appliances — Part 2: Pressure regulators for inlet pressures above 500 mbar up to and including 5 bar*

EN 161:2011, *Automatic shut-off valves for gas burners and gas appliances*

ISO 13577-3:2016(E)

DIN ISO 23553-1:2014, *Safety shut-off devices for combustion plants using liquid fuels; safety requirements and testing*;

EN 331:2013, *Manually operated ball valves and closed bottom taper plug valves for gas installations for buildings*

EN 334:2009, *Gas pressure regulators for inlet pressures up to 100 bar*

EN 751-1:1996, *Sealing materials for metallic threaded joints in contact with 1st, 2nd and 3rd family gases and hot water — Part 1: Anaerobic jointing compounds*

EN 751-2:1996, *Sealing materials for metallic threaded joints in contact with 1st, 2nd and 3rd family gases and hot water — Part 2: Non-hardening jointing compounds*

EN 1057:2006, *Copper and copper alloys — Seamless, round copper tubes for water and gas in sanitary and heating applications*

EN 10208-1:1997, *Steel pipes for pipe lines for combustible fluids — Technical delivery conditions — Part 1: Pipes of requirement class A*

EN 10208-2:2009, *Steel pipes for pipelines for combustible fluids — Technical delivery conditions — Part 2: Pipes of requirement class B*

EN 10241:2001, *Steel threaded pipe*

EN 10242:1995, *Threaded pipe fittings in malleable cast iron*

EN 10242/A1:1999, *Threaded pipe fittings in malleable cast iron*

EN 10242/A2:2003, *Threaded pipe fittings in malleable cast iron*

EN 10255:2004, *Non-Alloy steel tubes suitable for welding and threading — Technical delivery conditions*

EN 10255/A1:2007, *Non-Alloy steel tubes suitable for welding and threading — Technical delivery conditions*

EN 14382:2009, *Safety devices for gas pressure regulating stations and installations — Gas safety shut-off devices for inlet pressures up to 100 bar*

EN 13480-2:2013, *Metallic industrial piping — Part 2: Materials*

I.4 Requirements

I.4.1 Pipework, General

Additional to [4.2.1](#)

For steel pipes, compliance with EN 10208-1 and EN 10208-2, EN 13480-2 (Table A.3), or EN 10255 is considered appropriate. For copper pipes, compliance with EN 1057 is considered appropriate. Copper soldering connections shall not be used for gas carrying parts where the temperature could exceed 100 °C.

Threaded pipe fittings shall comply with EN 10241 or EN 10242.

I.4.1.1 Connections

Additional to [4.2.2](#)

Sealants for threads according to ISO 7-1 shall comply with EN 751, Part 1 or 2 as appropriate.

For diameters DN 50 to DN 80, threaded connections shall only be used for pressure up to 10 kPa.

I.4.1.2 Flexible tubing and couplings

Additional to [4.2.5](#)

The manual shut-off-valve shall comply with EN 331. For valves outside the scope of EN 331, the safety requirements detailed in EN 331 shall be met at an equivalent level.

I.4.1.2.1 Manual isolating valve

Additional to [4.3.1.2.1](#)

If technically applicable, only manual isolating valves complying with EN 331 shall be fitted. For valves outside the scope of EN 331, the safety requirements detailed in EN 331 shall be met at an equivalent level.

I.4.1.2.2 Pressure regulator and over pressure protection

Additional to [4.3.1.2.3](#)

Gas pressure regulators shall be in accordance with EN 88-1, EN 88-2 or EN 334 if applicable.

A mechanical over pressure cut-off device shall be in accordance with EN 14382.

I.4.1.2.3 Automatic shut-off valves

Additional to [4.3.1.2.5](#)

Automatic shut-off valve for gases shall be in accordance with EN 161.

Automatic shut-off valve for liquids shall be in accordance with ISO 23553-1 if applicable.

I.4.1.2.4 Generated atmosphere gas distribution — valves

Additional to [5.1.3.1](#)

The manual shut-off-valve shall comply with EN 331. For valves outside the scope of EN 331, the safety requirements detailed in EN 331 shall be met at an equivalent level.

Annex J (informative)

Overview of the terms defined in ISO 13574 (Vocabulary)

A

air pressure detector 2.1

air/fuel ratio 2.2

alternating pilot burner 2.12

analyser 2.3

atomization agent 2.4

automatic burner control system 2.5

automatic shut-off valve 2.194

auxiliary equipment 2.6

auxiliary flue 2.7

B

blowout device 2.8

brazing 2.9

burner 2.10

burner input rate 2.11

by-pass 2.26

C

calcining 2.27

calorific value 2.28

carbonitriding 2.31

carburising 2.32

cement, lime and gypsum industrial thermo-processing 2.33

ceramic industrial thermo-processing 2.34

check valve 2.200

chemical/petrochemical industrial thermo-processing 2.35

cleaning 2.36

closing force 2.195

closing time 2.197

coating 2.37
combustion air 2.38
combustion chamber 2.39
combustion safeguard 2.5
condensate drain 2.40
control system 2.41
controlled atmosphere gas 2.42

cooling 2.43

cooling water 2.44

core making 2.45

cracking 2.46

cross-ignited burner 2.13

D

decorating 2.47

degreasing 2.48

delacquering 2.49

de-waxing 2.50

differential pressure flow meter 2.51

distillation 2.52

drying 2.53

E

eductor 2.54

electrical generation efficiency 2.55

element 2.56

EMC 2.57

emergency safety-purge 2.145

endothermic/exothermic gas production 2.58

enriched air 2.59

exhaust gas 2.60

explosion relief 2.61

F

false air 2.93
fault tolerance time 2.62
filter/strainer 2.63
firing 2.64
first safety time 2.168
fixture/jig 2.95
flame arrestor 2.68
flame detector device 2.65
flame establishing period 2.167
flame failure response time (FFRT) 2.66
flame response time (FRT) 2.66
flame sensor 2.67
flame trap 2.68
flash back 2.69
fluids group 1 2.70
fluids group 2 2.71
food industrial thermo-processing 2.72
forced draught burner 2.14
functional safety 2.73

G

gas pressure regulator 2.74
gaseous fuel 2.75
gasifying 2.76
glass industrial thermo-processing 2.77
graded fuel 2.78
grate burner 2.15
gross calorific value 2.29

H

hardening 2.79
heat storage loss 2.80
heat treatment 2.81
heating 2.82

high temperature equipment 2.83

holding 2.84

holding (liquid phase) 2.85

hot dip galvanizing 2.86

I

ignition 2.87

impregnation 2.88

incineration of domestic refuse 2.89

incineration of industrial and special waste (such as toxic) 2.90

incineration of refuse derived fuel 2.91

incineration of sewage and sludge 2.92

induced draught burner 2.16

infiltration air 2.93

initial boiling point 2.94

J

jig/fixture 2.95

joining 2.96

L

lighting torch 2.97

liquefied natural gas (LNG) 2.98

liquefied petroleum gas (LPG) 2.99

liquid fuel 2.100

lock-out, non-volatile 2.101

logic function 2.102

logic solver 2.103

lower flammability limit (LFL) 2.104

low-temperature equipment 2.105

M

main flame 2.106

main flame establishing period 2.169

manual burner 2.17

manual isolating valve 2.198

manual reset 2.107

ISO 13577-3:2016(E)

manual shut-off valve 2.199
maximum allowable pressure 2.132
maximum/minimum allowable temperature (TS) 2.183
melting 2.108
melting out of metals 2.109
metallic coating 2.110
metallurgical industrial thermo-processing 2.111
multiple burner equipment 2.112

N

natural draught burner 2.18
net calorific value 2.30
nitriding 2.113
nitro-carburizing 2.114
nominal size (DN) 2.115
non-volatile lock-out 2.101
non-ferrous metal refining 2.116
non-metallic coating 2.117
non-return valve 2.200

O

open firing burner 2.19
operating temperature 2.118
operational safety-purge 2.144
operator supervision 2.119
oxidized substance 2.120
oxidizing 2.121

P

performance level (PL) 2.122
permanent pilot burner 2.20
pilot burner 2.21
pilot frame establishing period 2.168
pipework 2.123
piping 2.124
PLC (Programmable logic control) 2.125

polymerization 2.126
portable burner 2.22
preheating 2.127
pre-mix burner 2.23
pre-purge 2.142
pressure 2.128
pressure accessories 2.129
pressure equipment 2.130
pressure relief 2.61
pressure relief valve 2.201
pressure sintering 2.131
pressure, maximum allowable 2.132
processing chamber 2.133
process-purge 2.146
product 2.134
product standard 2.135
proof-of-closure switch 2.136
protective or reactive atmosphere 2.137
protective system 2.138
pulse firing 2.139
pulverised fuel 2.140
purge 2.141
purge point 2.147
pyrolyzing 2.148

Q

quenching 2.149

R

radiant tube burner 2.24
radiation thermometer 2.150
RC fan 2.151
recirculation fan 2.151
re-claiming used foundry sands 2.152
recuperator 2.153

ISO 13577-3:2016(E)

re-cycling 2.154

reducing 2.155

reference condition 2.156

reforming 2.157

regenerative burner 2.158

re-melting 2.159

remote reset 2.160

roasting 2.161

S

safe discharge area 2.162

safety accessories 2.163

safety bus 2.164

safety integrity level (SIL) 2.165

safety shut-down 2.166

safety time 2.167

safety time, first 2.168

safety time, second 2.169

safety-purge 2.143

sand drying and core making 2.170

sealing force 2.196

self-checking automatic burner control system 2.171

second safety time 2.169

sensible heat 2.172

single burner equipment 2.173

sintering 2.174

smelting 2.175

soldering 2.176

spark restoration 2.177

start fuel flow rate 2.178

steady-state 2.179

stoichiometric fuel rate 2.180

strainer/filter 2.63

surface pretreatment 2.181

surface treatment 2.182

systematic capability (SIL capability) 2.183

T

temperature, maximum/minimum allowable (TS) 2.184

tempering 2.185

test pressure 2.186

textile industrial thermo-processing 2.187

thermal production 2.188

thermocouple 2.189

thermo-processing equipment 2.190

torch 2.191

total closing time 2.192

trial for ignition period 2.167

V

valve proving system 2.193

vapour deposition 2.202

varnish drying 2.203

W

waste incineration industrial thermo-processing 2.204

welding 2.205

wobbe index 2.206

work station burner 2.25

Z

zone 2.2

Bibliography

- [1] ISO 49, *Malleable cast iron fittings threaded to ISO 7-1*
- [2] ISO 22967, *Forced draught gas burners*
- [3] ISO 22968, *Forced draught oil burners*
- [4] ISO 23551-4, *Safety and control devices for gas burners and gas-burning appliances — Particular requirements — Part 4: Valve-proving systems for automatic shut-off valves*
- [5] IEC 61508-1, *Functional safety of electrical/electronic/programmable electronic safety-related systems — Part 1: General requirements*
- [6] IEC 61511-1, *Functional safety — Safety instrumented systems for the process industry sector — Part 1: Framework, definitions, system, hardware and software requirements*
- [7] IEC 61511-2:2004, *Functional safety — Safety instrumented systems for the process industry sector — Part 2: Guidelines for the application of IEC 61511-1*
- [8] IEC 61511-3:2004, *Functional safety — Safety instrumented systems for the process industry sector — Part 3: Guidance for the determination of the required safety integrity levels*
- [9] IEC 62061:2005, *Safety of machinery — Functional safety of safety-related electrical, electronic and programmable electronic control systems*
- [10] EN 10352:2012-09, *Fibre-reinforced plastics—Moulding compounds and prepregs—Determination of mass per unit area (3rd Edition)*

