

# INTERNATIONAL STANDARD

# ISO 13562-1

First edition  
2000-12-15

---

---

## Industrial variable-reach trucks — Part 1: Stability tests

*Chariots de manutention à portée variable —  
Partie 1: Essais de stabilité*

This material is reproduced from ISO documents under  
International Organization for Standardization (ISO)  
Copyright License Number IHS/CC/1996. Not for resale.  
No part of these ISO documents may be reproduced in any  
form, electronic retrieval System or otherwise, except written  
consent of ISO (Case postal 56,1211 Geneva 20,  
Switzerland, FAX +41 22 734 10 79), IHS or the ISO  
Licensor's members.



Reference number  
ISO 13562-1:2000(E)

© ISO 2000

## ISO 13562-1:2000(E)

**PDF disclaimer**

This PDF file may contain embedded typefaces. In accordance with Adobe's licensing policy, this file may be printed or viewed but shall not be edited unless the typefaces which are embedded are licensed to and installed on the computer performing the editing. In downloading this file, parties accept therein the responsibility of not infringing Adobe's licensing policy. The ISO Central Secretariat accepts no liability in this area.

Adobe is a trademark of Adobe Systems Incorporated.

Details of the software products used to create this PDF file can be found in the General Info relative to the file; the PDF-creation parameters were optimized for printing. Every care has been taken to ensure that the file is suitable for use by ISO member bodies. In the unlikely event that a problem relating to it is found, please inform the Central Secretariat at the address given below.

© ISO 2000

All rights reserved. Unless otherwise specified, no part of this publication may be reproduced or utilized in any form or by any means, electronic or mechanical, including photocopying and microfilm, without permission in writing from either ISO at the address below or ISO's member body in the country of the requester.

ISO copyright office  
Case postale 56 • CH-1211 Geneva 20  
Tel. + 41 22 749 01 11  
Fax + 41 22 749 09 47  
E-mail [copyright@iso.ch](mailto:copyright@iso.ch)  
Web [www.iso.ch](http://www.iso.ch)

Printed in Switzerland

# Contents

Page

<b>Foreword</b> .....	<b>iv</b>
<b>1 Scope</b> .....	<b>1</b>
<b>2 Normative reference</b> .....	<b>1</b>
<b>3 Purpose of tests</b> .....	<b>1</b>
<b>3.1 Normal operating conditions</b> .....	<b>1</b>
<b>3.2 Operating under conditions other than normal</b> .....	<b>2</b>
<b>4 Stability tests</b> .....	<b>2</b>
<b>4.1 Test requirements</b> .....	<b>2</b>
<b>4.2 Verification procedure</b> .....	<b>2</b>
<b>4.3 Test conditions</b> .....	<b>2</b>
<b>5 Stability tests for trucks with attachments</b> .....	<b>5</b>
<b>Bibliography</b> .....	<b>10</b>

**ISO 13562-1:2000(E)****Foreword**

ISO (the International Organization for Standardization) is a worldwide federation of national standards bodies (ISO member bodies). The work of preparing International Standards is normally carried out through ISO technical committees. Each member body interested in a subject for which a technical committee has been established has the right to be represented on that committee. International organizations, governmental and non-governmental, in liaison with ISO, also take part in the work. ISO collaborates closely with the International Electrotechnical Commission (IEC) on all matters of electrotechnical standardization.

International Standards are drafted in accordance with the rules given in the ISO/IEC Directives, Part 3.

Draft International Standards adopted by the technical committees are circulated to the member bodies for voting. Publication as an International Standard requires approval by at least 75 % of the member bodies casting a vote.

Attention is drawn to the possibility that some of the elements of this part of ISO 13562 may be the subject of patent rights. ISO shall not be held responsible for identifying any or all such patent rights.

International Standard ISO 13562-1 was prepared by Technical Committee ISO/TC 110, *Industrial trucks*, Subcommittee SC 2, *Safety of powered industrial trucks*. It is based on annex A of EN 1726-1:1998.

ISO 13562 consists of the following parts, under the general title *Industrial variable-reach trucks*:

- *Part 1: Stability tests*
- *Part 2: Additional stability tests for trucks handling freight containers of length 6 m and above*

# Industrial variable-reach trucks —

## Part 1: Stability tests

### 1 Scope

This part of ISO 13562 specifies basic tests to verify the stability of industrial variable-reach fork-lift trucks.

It applies to self-propelled, seated rider operated, counterbalanced industrial variable-reach fork-lift trucks

- with non-slewing booms or with a slewing movement not greater than 5° either side of the longitudinal centre plane of the truck,
- fitted with fork arms or load-handling attachments,
- with a fixed or articulated chassis,
- that may have stabilizers, axle-locking or frame-levelling devices, and
- with two- or four-wheel or articulated steering systems.

This part of ISO 13562 is not applicable to the above trucks when they are handling suspended loads which may swing freely.

### 2 Normative reference

The following normative document contains provisions which, through reference in this text, constitute provisions of this part of ISO 13562. For dated references, subsequent amendments to, or revisions of, this publication do not apply. However, parties to agreements based on this part of ISO 13562 are encouraged to investigate the possibility of applying the most recent edition of the normative document indicated below. For undated references, the latest edition of the normative document referred to applies. Members of ISO and IEC maintain registers of currently valid International Standards.

ISO 5353:1995, *Earth-moving machinery, and tractors and machinery for agriculture and forestry — Seat index point.*

### 3 Purpose of tests

#### 3.1 Normal operating conditions

The basic tests specified in this part of ISO 13562 ensure that the type of truck specified has satisfactory stability when reasonably and appropriately used under the following normal operating conditions:

- a) stacking with the fork arms reasonably horizontal, with the truck on substantially firm, smooth, level and prepared surfaces;

**ISO 13562-1:2000(E)**

- b) travelling with the load in the lowered and retracted (travelling) position, with the truck on substantially firm, smooth and prepared surfaces;
- c) operating with the load centre of gravity approximately on the longitudinal centre plane of the truck.

**3.2 Operating under conditions other than normal**

When the operating conditions differ from those specified in 3.1, it is necessary to use either

- a) a truck complying with other International Standards covering different specific conditions (e.g. ISO 10658), or
- b) a truck whose stability is agreed upon between the interested parties. This agreed stability shall not be less than that required by the tests specified for normal operating conditions in 3.1.

**4 Stability tests****4.1 Test requirements**

The stability of industrial variable-reach fork-lift trucks shall be verified by one of the procedures specified in 4.2.

**4.2 Verification procedures****4.2.1 Tilting platform**

Use a test platform that can be tilted about one side. Place the truck being tested for stability on the initially horizontal test platform, in accordance with 4.3 and, successively, in each of the positions described in Table 3.

In each of the tests, tilt the test platform slowly to the slope specified in Table 3.

The truck is considered stable if it passes all tests without overturning. For the purposes of the tests, overturning is defined as the test platform slope value that, if increased, would cause the truck to overturn.

It is permissible in lateral tests for one load wheel to lose contact with the test platform. It is acceptable for parts of the structure or designed features to make contact with the test platform.

**4.2.2 Fixed slope**

Use fixed slopes with inclinations equivalent to the specified test slope. The slope surface shall be smooth and capable of supporting the truck mass with no deformation that could affect the test results.

Drive the truck under test onto the fixed slopes with the boom in the lowered and retracted position and positioned as specified in Table 3. For each of the truck positions with an elevated load or load carrier, the boom shall be elevated and extended smoothly to the position specified in Table 3.

**4.2.3 Calculation**

Determine compliance with the specified stability values by calculation methods verified by empirical data.

The calculated capacities shall take into account manufacturing variations and deflections of the boom, tyres, etc.

**4.3 Test conditions****4.3.1 Condition of the truck**

The tests shall be carried out on an operational truck.

The operator shall be simulated by an object having a mass of 90 kg if the stability during a test is thereby decreased. The centre of gravity of the object shall be secured 150 mm above the seat index point (SIP) as determined in accordance with ISO 5353, with the seat at the closest position to the midpoint of the adjustments provided.

Fuel tanks of internal combustion engine trucks shall be full if the stability is thereby decreased. All other tanks shall be filled to their correct operating levels, as applicable.

Tyres shall be inflated to the pressure specified by the truck manufacturer. Where tyre ballast is incorporated in the truck design, the use of ballast shall be in accordance with the truck manufacturer's instructions.

#### 4.3.2 Position of truck on platform

For tests 1 and 2 (see Table 3), the truck shall be placed on the test platform or slope so that the load axle is parallel to the tilt axis, XY, of the test platform.

For tests 3, 4 and 5 (see Table 3), the truck shall be placed on the test platform or slope in a turning position with the line MN parallel to the tilt axis, XY, of the test platform.

For trucks with an oscillating steer axle, the wheel on the steer axle nearest to the platform tilt axis shall be parallel to the platform tilt axis.

Lateral stability tests shall be conducted on the side of the truck which is the less stable.

Point N is the centre point of the area of contact between the test platform surface and the front wheel or stabilizer pad nearest to the tilting axis of the test platform.

Point M is defined as follows.

- a) For trucks with an oscillating steer axle: the projection onto the test platform of the intersection of the longitudinal centre plane, AB, of the truck with the axis of the steer axle.
- b) For trucks with an articulated chassis: the projection onto the test platform of the intersection of the longitudinal centre plane, EF, of the rear chassis module and the axis of the rear axle.
- c) For trucks with axle locking: the centre point of the area of contact between the test platform and the rear wheel nearest the test platform tilting axis.

#### 4.3.3 Test load

The test load shall have a mass equivalent to the maximum load,  $Q$ , which the truck can elevate to its maximum lift height acting through the centre of gravity,  $G$ , nominally positioned at the standard load centre distance,  $D$ , as indicated on the capacity plate of the truck both horizontally from the front face of the fork arm shank and vertically from the upper face of the fork arm blade (see Figure 1).

When additional lift heights, loads and load centre distances are to be indicated on the capacity plate, the truck shall meet the requirements established by the tests specified in this part of ISO 13562 for these additional ratings.

The centre of gravity,  $G$ , of the test load shall be located on the longitudinal centre plane, AB, of the truck.

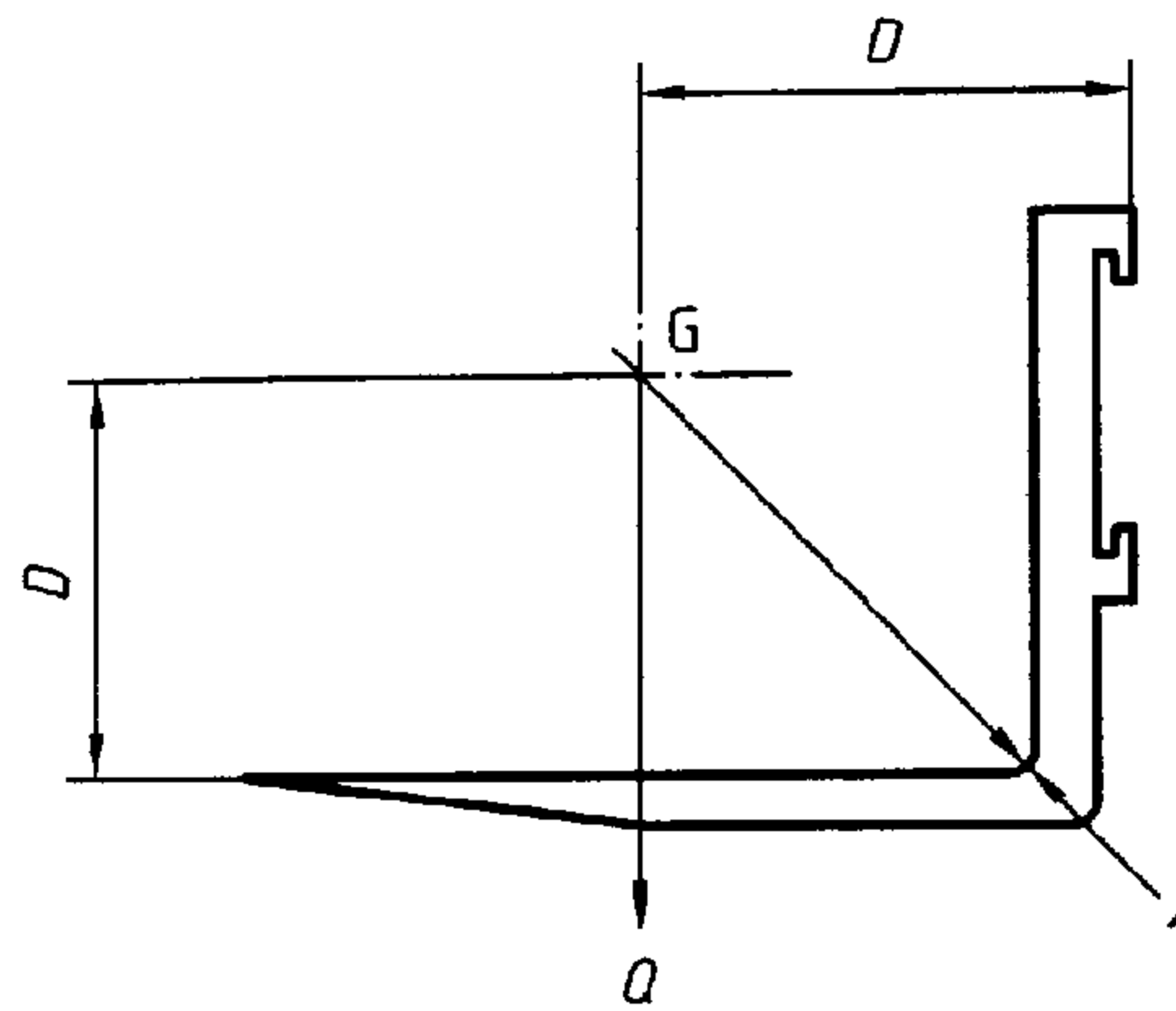

**Key**

1 Inside heel of fork arm

NOTE See 4.3.3 for explanation of symbols.

**Figure 1 — Test load centre of gravity**

**Table 1 — Standard load centre distance**

Load, $Q$ kg	Load centre distance, $D$ mm
$Q < 1\ 000$	400
$1\ 000 \leq Q \leq 4\ 999$	500
$5\ 000 \leq Q \leq 10\ 000$	600
$Q > 10\ 000$	600, 900, 1 200 or 1 500

**4.3.4 Location of the truck on the test platform**

The location of the truck on the test platform or slope shall be maintained during each test.

This may be achieved by application of parking or service brakes, which can be secured in the “on” position, or by wedging the wheels against the truck frame, ensuring however that the articulation is not affected.

Blocks (chocks) with a maximum height not exceeding the value indicated in Table 2 may be used, if necessary, to maintain the initial position of the truck on the test platform or slope. Blocks (chocks), if used, shall not artificially improve stability.

**Table 2 — Height of blocks**

Tyre outside diameter, $d$ mm	Max. height of blocks mm
$d \leq 250$	25
$250 < d \leq 500$	$0,1d$
$d > 500$	50

The coefficient of friction of the platform surface or slope may be increased, if required, by an appropriate friction-increasing material.



#### 4.3.5 Position of load/fork arms

##### 4.3.5.1 Stacking tests

Tests 1 and 3 shall be conducted with the load in the least stable combination of lift and reach, as determined by the manufacturer, with the fork arms in the horizontal position.

Test 5 shall be conducted at maximum and minimum boom extension, at maximum boom angle with the fork arms in the horizontal position.

##### 4.3.5.2 Travelling

For tests 2 and 4, the upper face of the fork arms, measured at the heels of the fork arms when fully tilted rearward, shall be positioned approximately 500 mm from the test platform.

#### 4.3.6 Trucks with selectable stabilizers and/or axle locking

Tests 1 and 3 shall be conducted with stabilizers/axle-locking engaged and disengaged.

#### 4.3.7 Safety precautions

Precautions shall be taken to prevent the truck overturning or displacement of the load during the tests. If the truck is prevented from overturning by rope lashing or chain, this shall be sufficiently slack to impose no appreciable restriction on the truck until the overturning point is reached.

Displacement of the test load shall be prevented by means such as the following:

- a) firmly securing the test load to the load carrier or equivalent structure;
- b) suspending the test load near to the ground from an appropriate support placed on the fork arms so that the suspension point is at the point where the centre of gravity,  $G$ , of the test load would be if the test load were placed on the fork arms.

### 5 Stability tests for trucks with attachments

Trucks fitted with attachments other than fork arms shall be subject to the same stability tests, except in cases where the attachment can bring the centre of gravity of the load out of the longitudinal centre plane, AB, of the truck [see 3.1 c)].

The test load shall be the actual load, at the specified load centre distance indicated for the attachment when used on the truck being tested.

The lift height required in the tests shall be measured between the surface of the tilting platform and the underside of the load in its approved handling position or the underside of the load engaging means, whichever is the smaller.

Table 3 — Summary of tests

Test	1	2	3	4	5
<b>Stability</b>	<b>Longitudinal</b>		<b>Lateral</b>		
Operation	Stacking	Travelling	Stacking	Travelling	Stacking
Load	Test load	Test load	Test load	Unladen	Unladen
Lift height	Least stable lift and reach combination with fork arms in the horizontal position	Lowered (see 4.3.5.2)	Least stable lift and reach combination with fork arms in the horizontal position	Lowered (see 4.3.5.2)	Maximum and minimum boom extension at maximum boom angle with fork arms in the horizontal position
Stabilizer device and/or axle locking	With and without	Without	With and without	Without	Without
Correction for lateral tilt	Without	Without	With	Without	Without
Position on test platform	Figure 2	Figure 3	Figures 4 and 7, 8, 9, 10 or 11	Figures 5 and 8, 9, 10 or 11	Figures 6 and 8, 9, 10 or 11
<b>Slope of test platform</b>					
Rated capacity up to and including 10 000 kg	4 %	18 %	6 %	(15 + 1,4v <sub>s</sub> ) % max. 50 %	6 %
Rated capacity above 10 000 kg	3,5 %	18 %	6 %	(15 + 1,4v <sub>s</sub> ) % max. 40 %	6 %
v <sub>s</sub> is the maximum speed of an unladen truck, in kilometres per hour.					

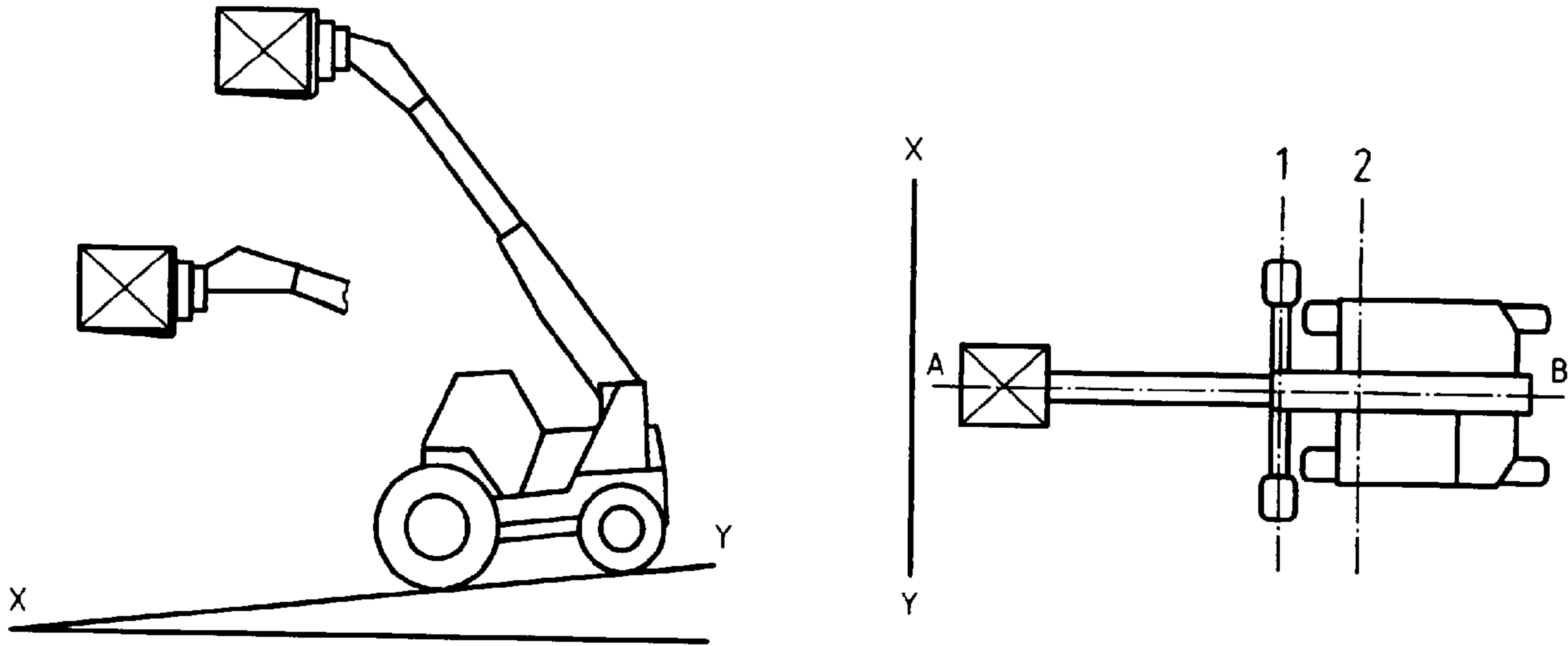

**Key**

- 1 Stabilizer axis
- 2 Load axle

XY is the tilt axis.

AB is the longitudinal central plane.

**Figure 2 — Position of truck for test 1**

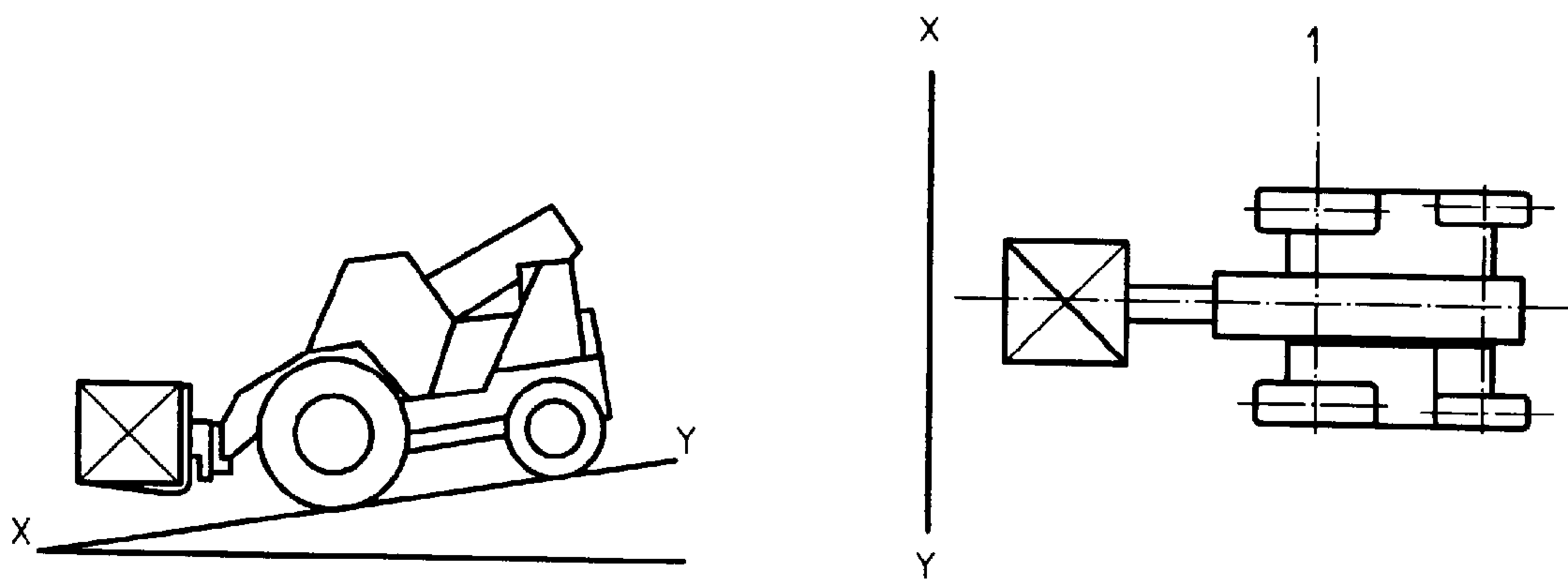

**Key**

- 1 Load axle

XY is the tilt axis.

**Figure 3 — Position of truck for test 2**

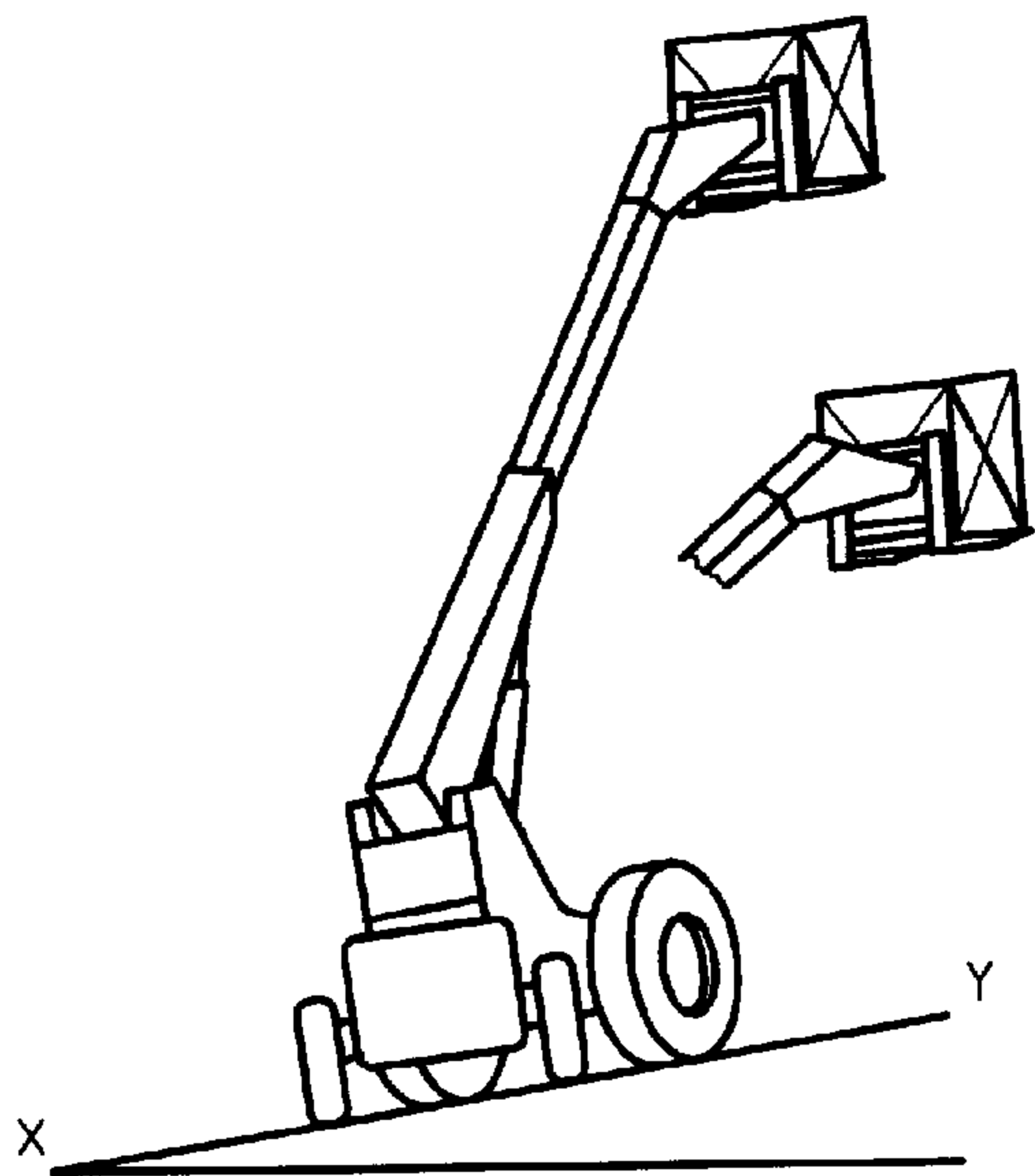

XY is the tilt axis.

Figure 4 — Position of truck for test 3

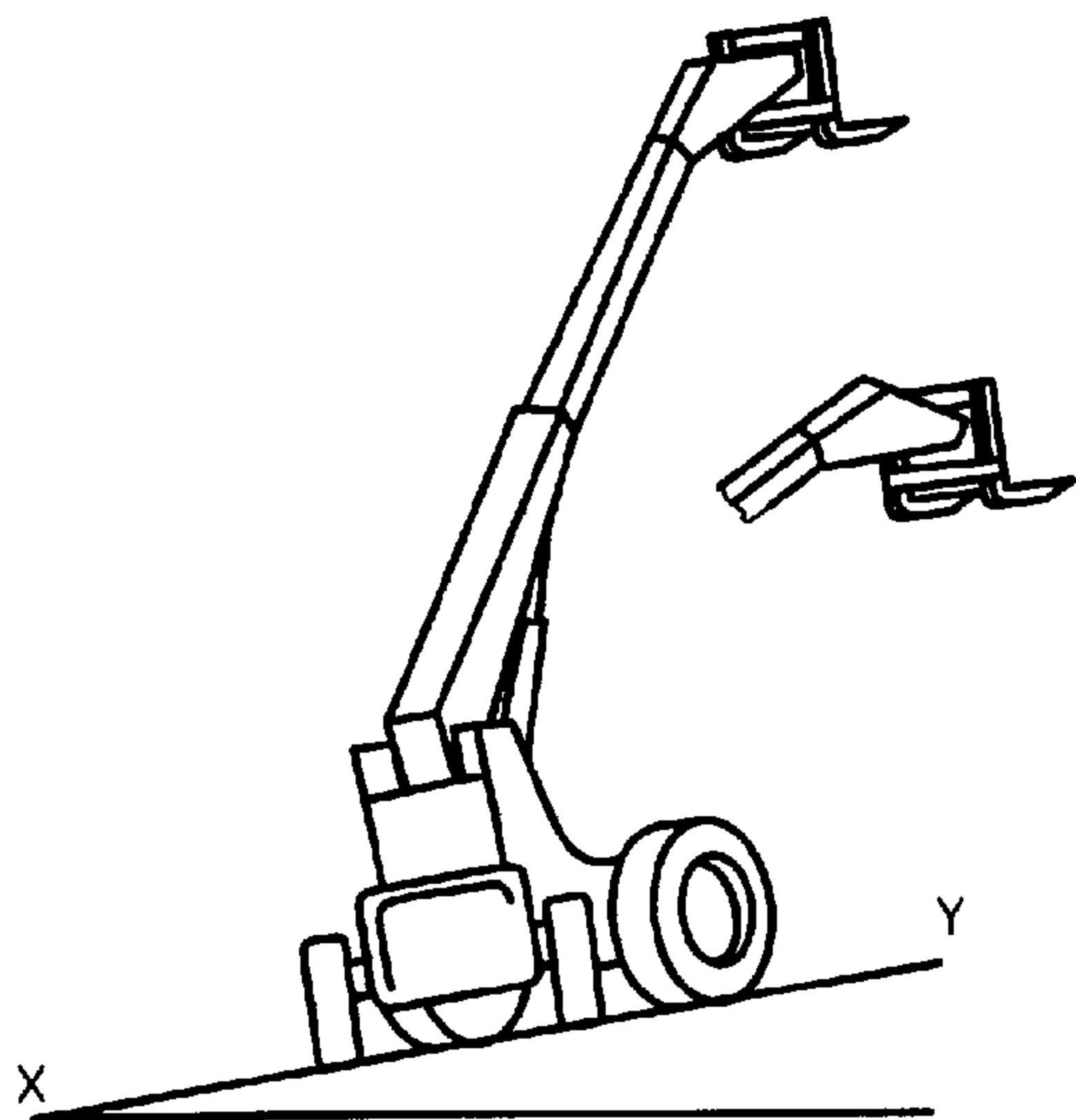

XY is the tilt axis.

Figure 6 — Position of truck for test 5

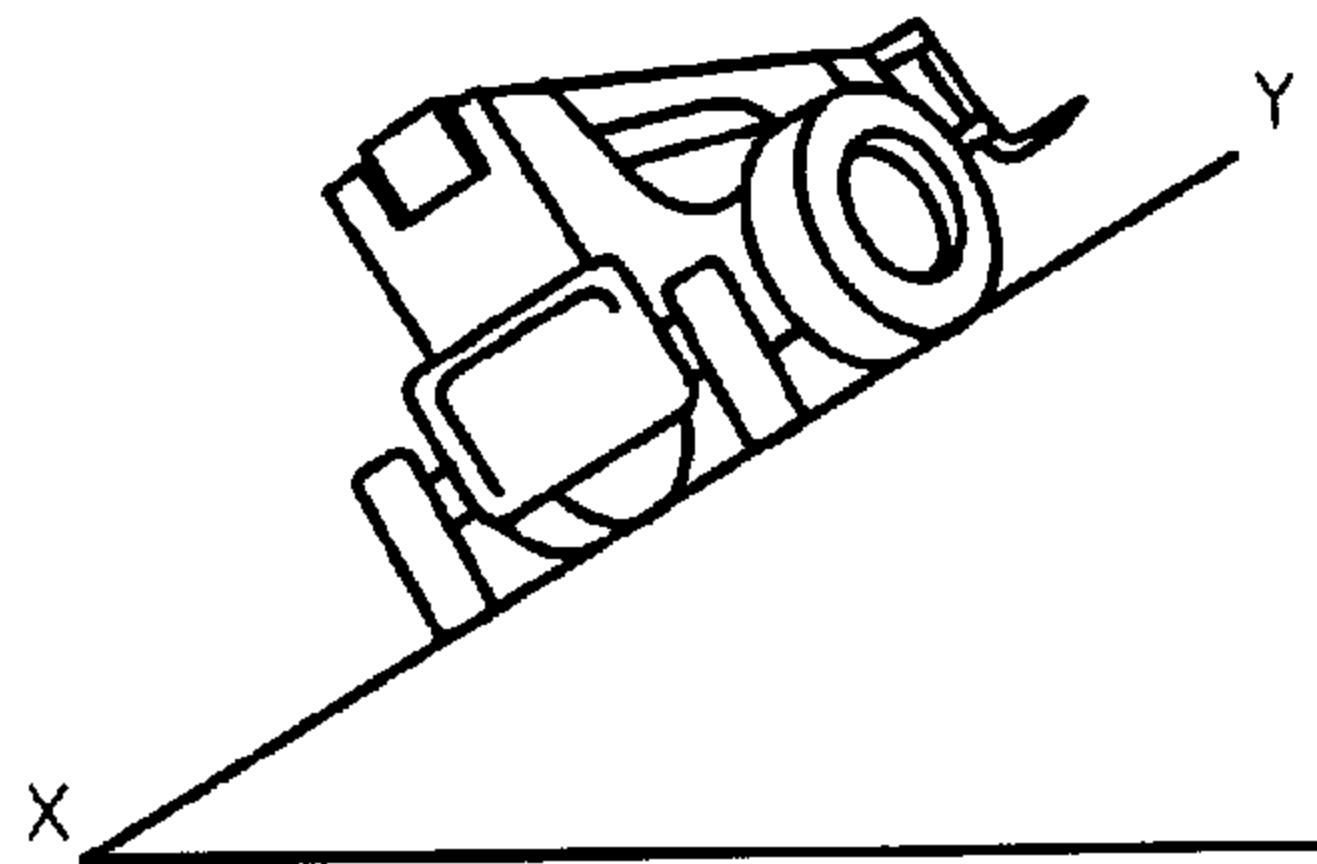

XY is the tilt axis.

Figure 5 — Position of truck for test 4

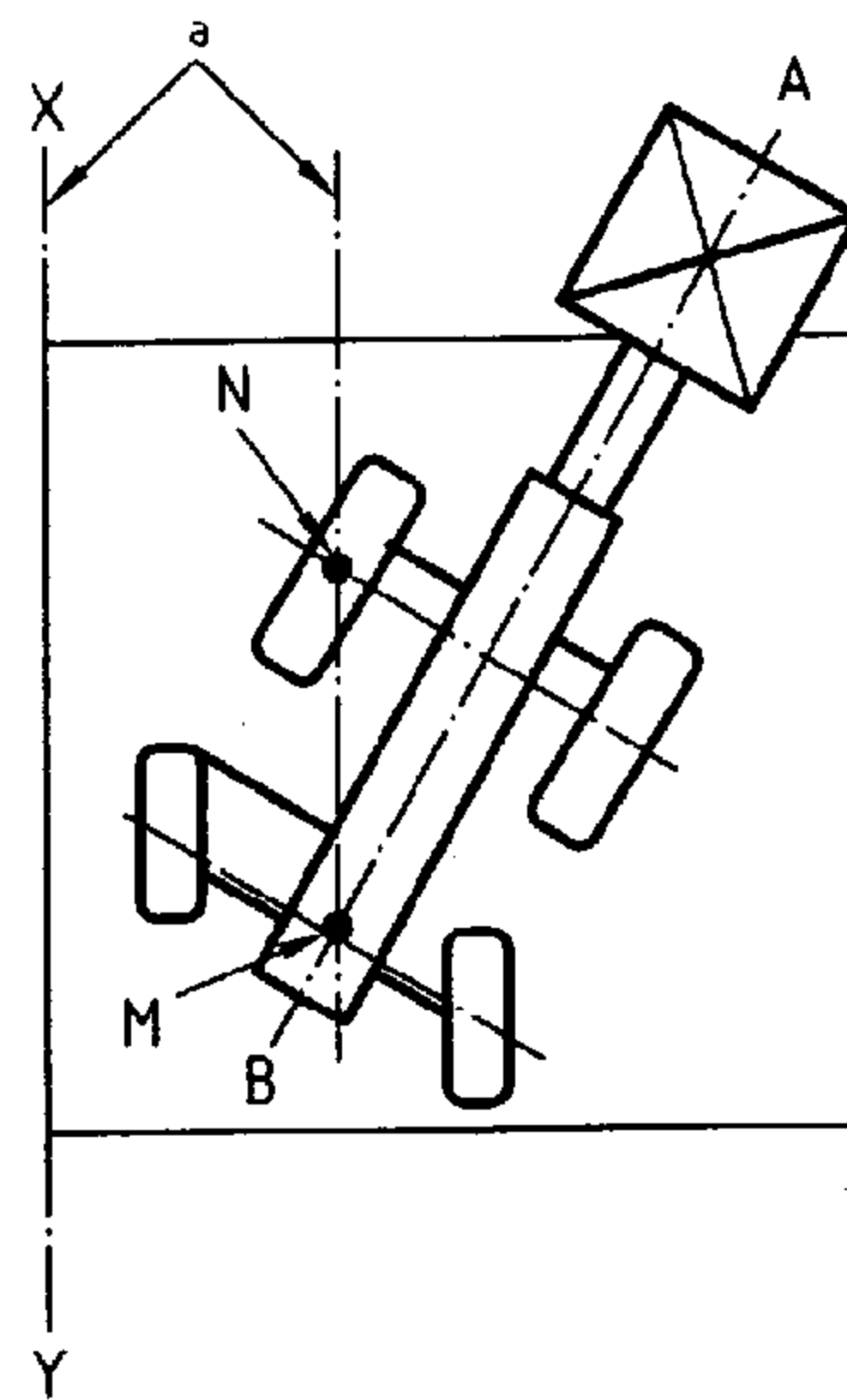

a Parallel.

NOTE See 4.3.2 for explanation of symbols.

Figure 7 — Truck with oscillating axle (two-wheel steer)

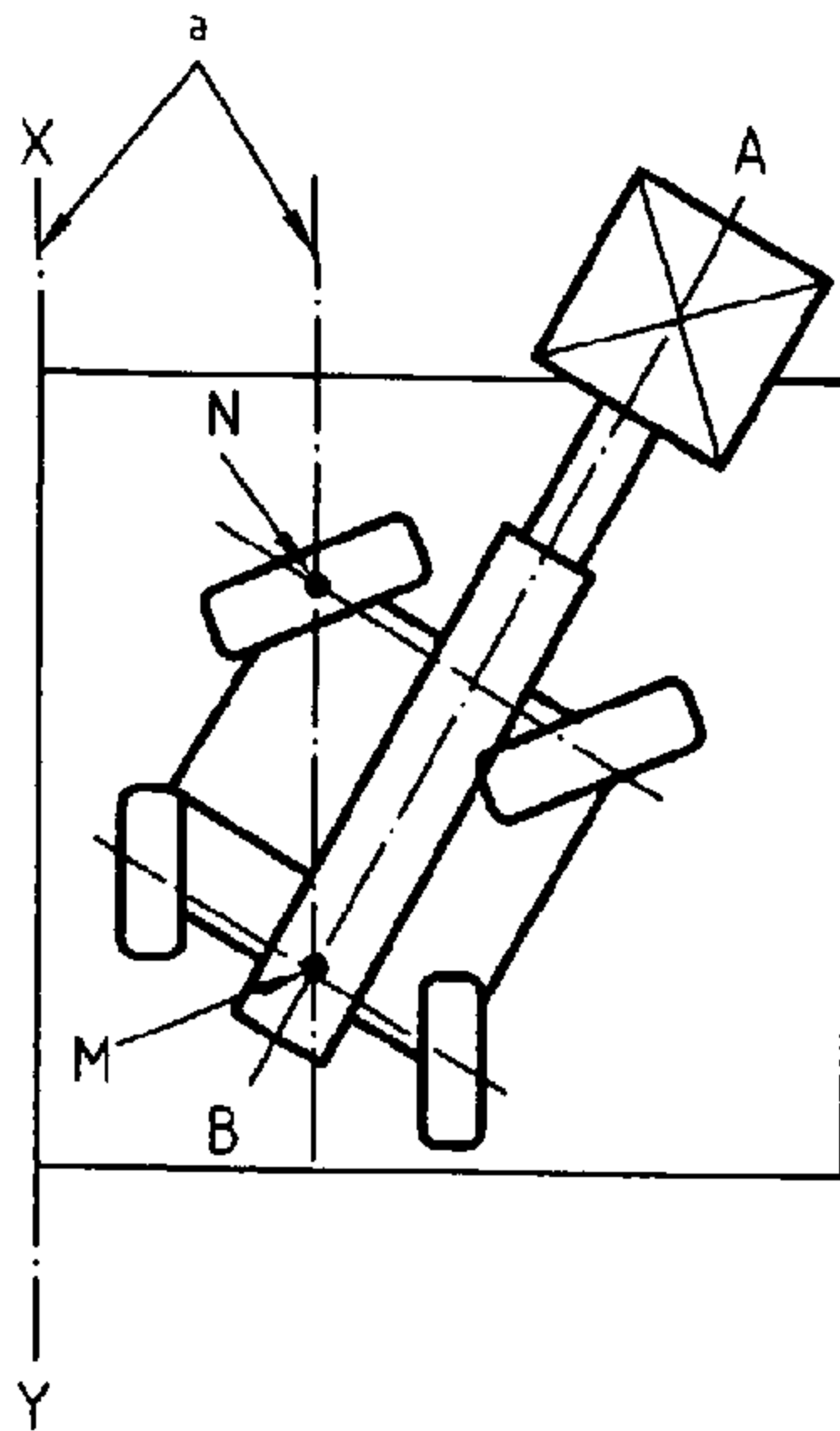

a Parallel.

NOTE See 4.3.2 for explanation of symbols.

**Figure 8 — Truck with oscillating axle (four-wheel steer)**

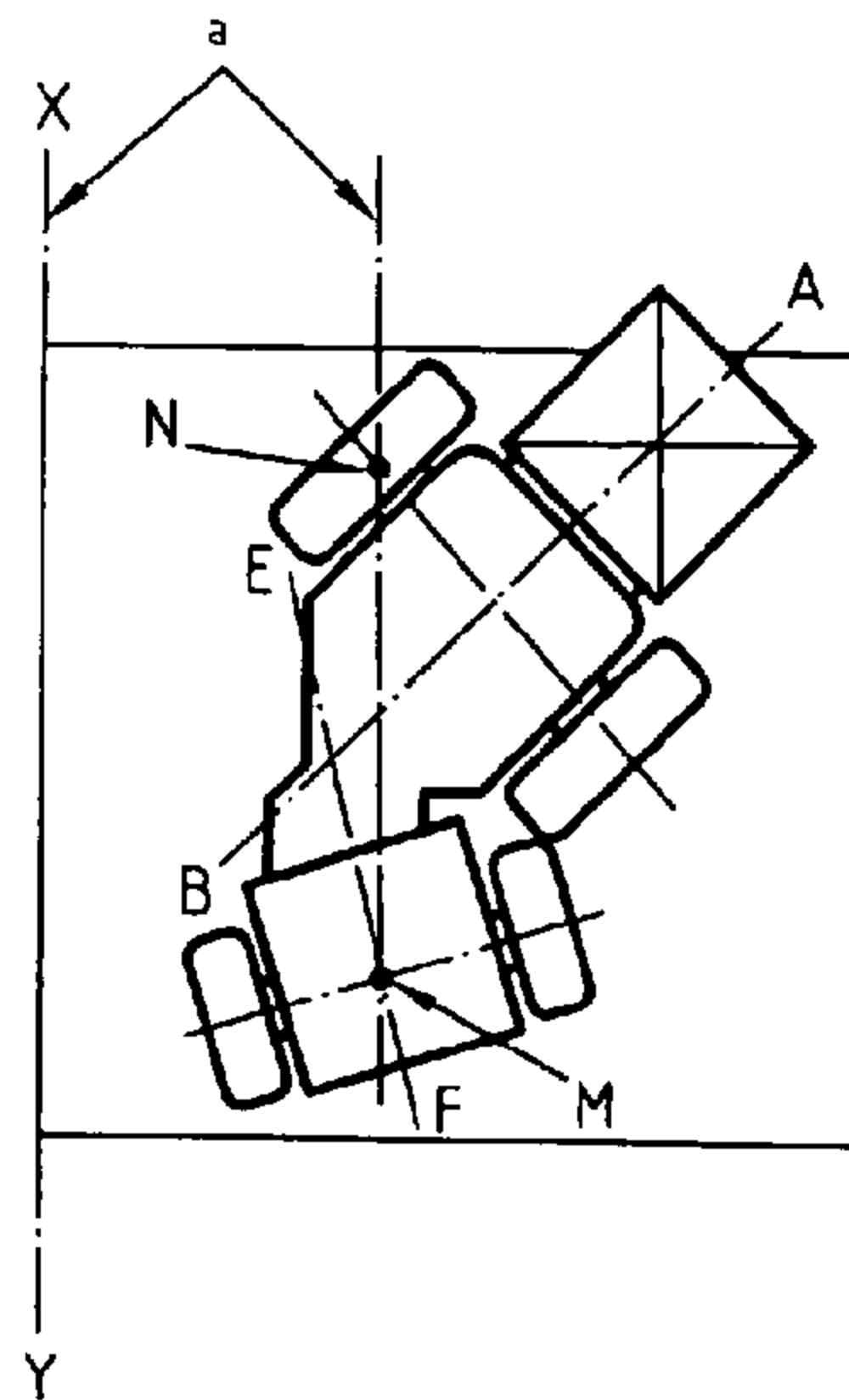

a Parallel.

NOTE See 4.3.2 for explanation of symbols.

**Figure 9 — Truck with articulated steering**

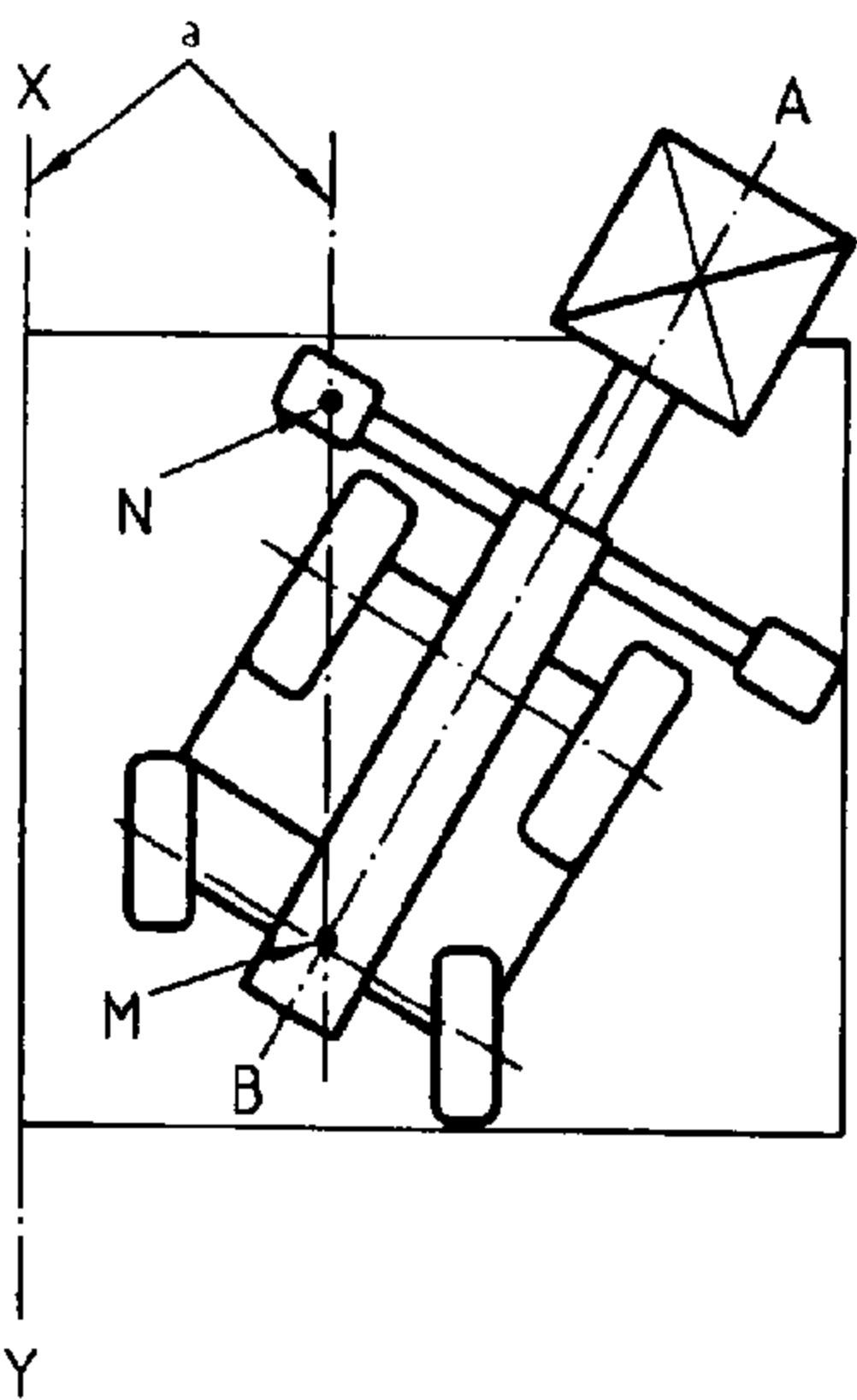

a Parallel.

NOTE See 4.3.2 for explanation of symbols.

**Figure 10 — Stabilized truck**

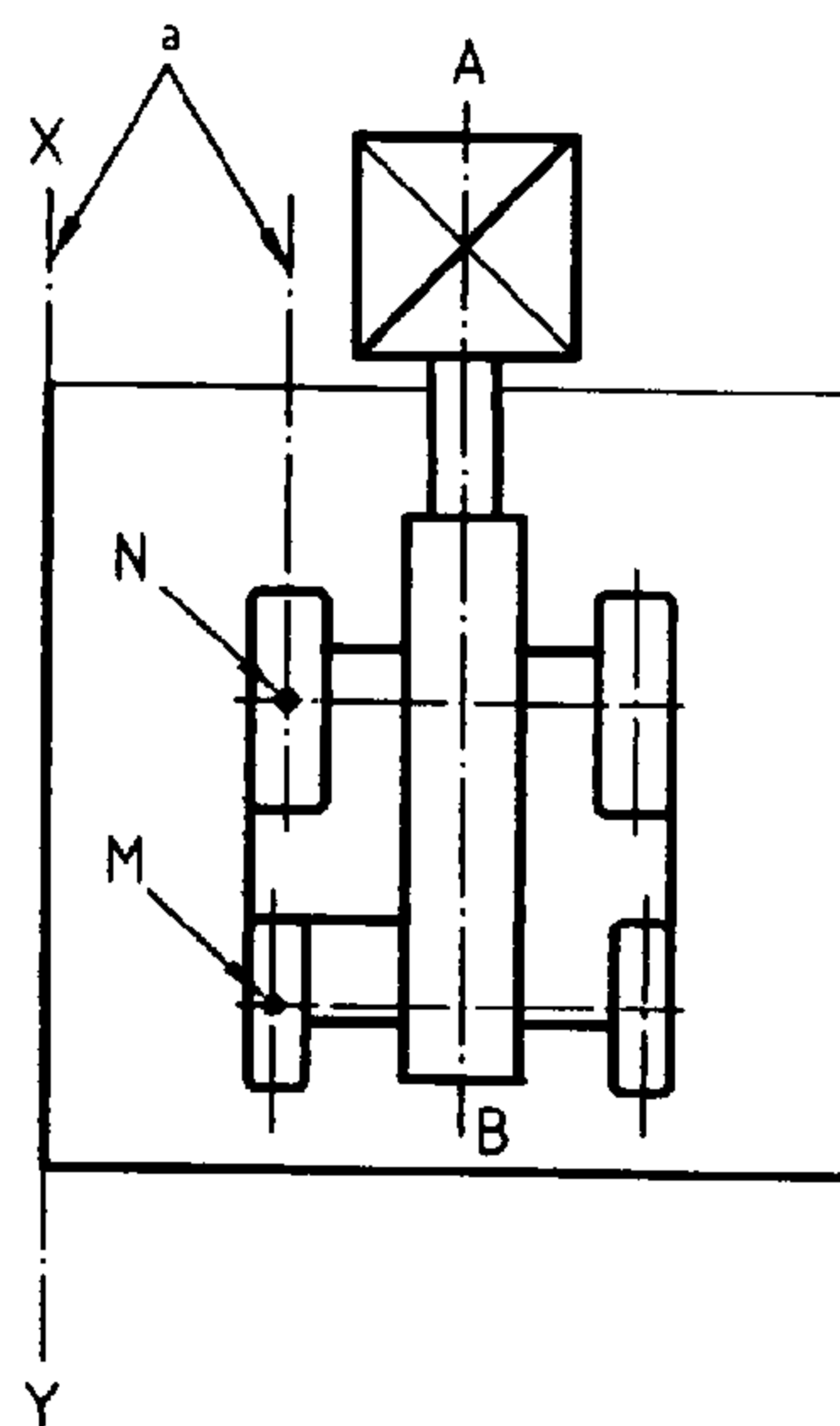

a Parallel.

NOTE See 4.3.2 for explanation of symbols.

**Figure 11 — Truck with axles locked**

## Bibliography

- [1] ISO 10658:1996, *Industrial trucks operating in special conditions of stacking with load laterally displaced by powered devices — Additional stability tests.*
- [2] EN 1726-1:1998, *Safety of industrial trucks — Self-propelled trucks up to and including 10 000 kg capacity and industrial tractors with a drawbar pull up to and including 20 000 N — Part 1: General requirements.*

ISO 13562-1:2000(E)

---

---

**ICS 53.060**

Price based on 10 pages

© ISO 2000 – All rights reserved

正文