**Petroleum and natural gas
industries — Completion fluids and
materials —**

**Part 6:
Procedure for measuring leakoff of
completion fluids under dynamic
conditions**

*Industries du pétrole et du gaz naturel — Fluides de complétion et
matériaux —*

*Partie 6: Mode opératoire pour le mesurage de la perte de fluide par
filtration en conditions dynamiques des fluides de complétion*





COPYRIGHT PROTECTED DOCUMENT

© ISO 2014

All rights reserved. Unless otherwise specified, no part of this publication may be reproduced or utilized otherwise in any form or by any means, electronic or mechanical, including photocopying, or posting on the internet or an intranet, without prior written permission. Permission can be requested from either ISO at the address below or ISO's member body in the country of the requester.

ISO copyright office
Case postale 56 • CH-1211 Geneva 20
Tel. + 41 22 749 01 11
Fax + 41 22 749 09 47
E-mail copyright@iso.org
Web www.iso.org

Published in Switzerland

Contents

	Page
Foreword	iv
Introduction	v
1 Scope	1
2 Terms and definitions	1
3 Cell type	2
4 Identification of test parameters (linear flow cells)	3
4.1 General.....	3
4.2 Temperature.....	3
4.3 Pressure.....	4
4.4 Test duration.....	4
4.5 Shear rate.....	4
4.6 Permeability.....	4
4.7 Fluid shear-history simulator (optional).....	4
4.8 Heat-up rate.....	4
5 Test procedure	4
5.1 Core preparation.....	4
5.2 Round cell.....	5
5.3 Proppant conductivity cell.....	5
6 Calculations	6
6.1 Shear rate.....	6
6.2 Leakoff coefficients.....	6
7 Calculation examples	8
7.1 Round cell — Linear gel.....	8
7.2 Round cell — Crosslinked gel.....	10
7.3 Proppant conductivity cell — Crosslinked gel.....	11
8 Report	12
Bibliography	14

Foreword

ISO (the International Organization for Standardization) is a worldwide federation of national standards bodies (ISO member bodies). The work of preparing International Standards is normally carried out through ISO technical committees. Each member body interested in a subject for which a technical committee has been established has the right to be represented on that committee. International organizations, governmental and non-governmental, in liaison with ISO, also take part in the work. ISO collaborates closely with the International Electrotechnical Commission (IEC) on all matters of electrotechnical standardization.

International Standards are drafted in accordance with the rules given in the ISO/IEC Directives, Part 2.

The main task of technical committees is to prepare International Standards. Draft International Standards adopted by the technical committees are circulated to the member bodies for voting. Publication as an International Standard requires approval by at least 75 % of the member bodies casting a vote.

Attention is drawn to the possibility that some of the elements of this document may be the subject of patent rights. ISO shall not be held responsible for identifying any or all such patent rights.

ISO 13503-6 was prepared by Technical Committee ISO/TC 67, *Materials, equipment and offshore structures for petroleum, petrochemical and natural gas industries*, Subcommittee SC 3, *Drilling and completion fluids, and well cements*.

ISO 13503 consists of the following parts, under the general title *Petroleum and natural gas industries — Completion fluids and materials*:

- *Part 1: Measurement of viscous properties of completion fluids*
- *Part 2: Measurement of properties of proppants used in hydraulic fracturing and gravel-packing operations*
- *Part 3: Testing of heavy brines*
- *Part 4: Procedure for measuring stimulation and gravel-pack fluid leakoff under static conditions*
- *Part 5: Procedures for measuring the long-term conductivity of proppants*
- *Part 6: Procedure for measuring leakoff of completion fluids under dynamic conditions*

Introduction

The objective of this part of ISO 13503 is to provide a procedure for measuring fluid loss (leakoff) under dynamic conditions. This procedure was compiled on the basis of several years of comparative testing, debate, discussion and continued research by the industry.

Dynamic fluid loss testing consists of a simulation of the circulation process where completion fluid loss occurs at a core face with appropriate shear conditions. Under dynamic conditions, the filter cake deposition and fluid loss behaviour are different to those of fluid loss under static conditions.

Laboratory leakoff tests have shown that there is a dynamic effect for low-permeability formations, i.e. $< 1,0$ mD. This is due to the fact that the filter cake develops at the core surface and the shear effect controls the thickness. However, for high-permeability formations, i.e. > 50 mD, the dynamic effect is relatively small because the fluid system that penetrates the fracture face forms minimum filter cake.

The determination of the fluid loss coefficients is simply a quadratic regression of the data, with time and square root of time as variables.

In this part of ISO 13503, where practical, US Customary (USC) units are included in parentheses for information. The units do not necessarily represent a direct conversion of SI to USC units, or vice versa. Consideration has been given to the precision of the instrument making the measurement.

Petroleum and natural gas industries — Completion fluids and materials —

Part 6: Procedure for measuring leakoff of completion fluids under dynamic conditions

1 Scope

This part of ISO 13503 provides consistent methodology for measuring the fluid loss of completion fluids under dynamic conditions. This part of ISO 13503 is applicable to all completion fluids except those that react with porous media.

2 Terms and definitions

For the purposes of this document, the following terms and definitions apply.

2.1

backpressure

constant pressure maintained at the leakoff port

2.2

cell

tool that contains the core and maintains test conditions such as test temperature and confining pressure

NOTE Cell orientation is defined according to whether the long axes of the core are horizontal or vertical.

2.3

filter cake

build-up of materials on core face or within the porous medium

2.4

filtrate

fluid exiting the core

2.5

fluid inlet

point at which fluid enters the gap

2.6

fluid loss

measure of fluid volume that leaks into a porous medium over time

2.7

gap

linear distance from the core face to the wall opposite the core face

2.8

shear-history simulator

apparatus used to simulate shear history in a fluid

[SOURCE: ISO 13503-1:2011, definition 2.10]

3 Cell type

There are two different types of cell for measuring fluid loss under dynamic conditions:

- a) round cell: an example is shown in Figure 1;
- b) proppant conductivity cell: an example is shown in Figure 2 (see also ISO 13503-5:2006, Figure C.1).

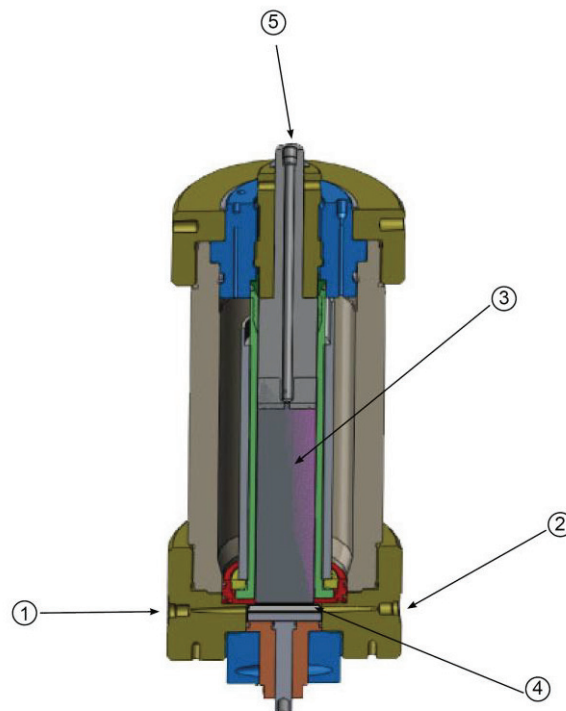

Key

- 1 inlet port
- 2 outlet port
- 3 porous medium (core)
- 4 gap
- 5 leakoff outlet

Figure 1 — Schematic of a typical round cell

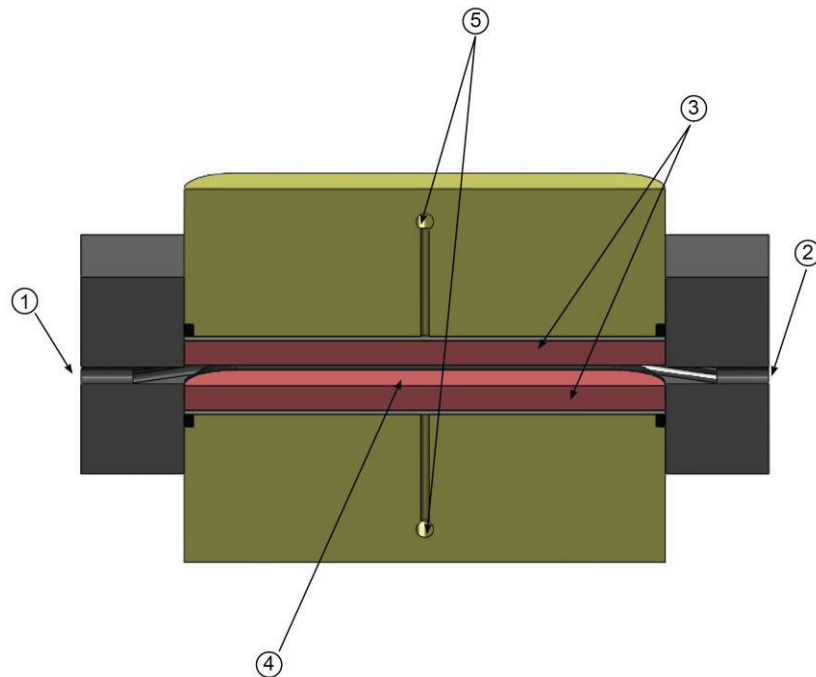
**Key**

- 1 inlet port
- 2 outlet port
- 3 porous medium (core)
- 4 gap
- 5 leakoff outlet

Figure 2 — Schematic of a typical proppant conductivity cell

4 Identification of test parameters (linear flow cells)

4.1 General

All calibrations shall be performed in accordance with the manufacturer's recommendations.

4.2 Temperature

4.2.1 General considerations

Temperatures shall be measured to within ± 1 °C (± 2 °F) and stabilized to within ± 3 °C (± 5 °F) of the test temperature.

4.2.2 Test temperature

The test temperature is the simulated temperature as defined by the fluid and cell temperatures.

4.2.3 Fluid temperature

Fluid temperature is the temperature of the test fluid measured at the fluid inlet.

4.2.4 Cell temperature

Cell temperature is the internal cell temperature representing the core temperature.

4.3 Pressure

4.3.1 Test pressure

Test pressure is the differential fluid pressure across the core length. It may be measured by a differential pressure transducer or calculated by subtracting the backpressure from the fluid pressure. It shall be controlled at 5 % of the design pressure.

4.3.2 Fluid pressure

Fluid pressure is the pressure at the core face.

4.3.3 Backpressure

Backpressure is the pressure of the filtrate as it exits the core.

4.3.4 Confining pressure

The confining pressure is the pressure used to seal the core if a Hassler sleeve is used.

4.4 Test duration

The test begins when the differential fluid pressure is applied and shall continue for a minimum of 60 min.

4.5 Shear rate

The shear rate of the test fluid across the core face shall be $40 \text{ s}^{-1} \pm 25 \%$.

4.6 Permeability

Using a compatible fluid, determine the permeability of the core prior to the test.

4.7 Fluid shear-history simulator (optional)

Shear-sensitive fluids may be conditioned through a shear-history simulator as described in ISO 13503-1 and specified by the following parameters:

- a) tubing length;
- b) tubing inside diameter;
- c) flow rate.

4.8 Heat-up rate

Within 15 min or less, the fluid temperature at the inlet shall be no lower than 5 % below and no higher than 3 °C (5 °F) above the desired test temperature. The inlet temperature shall be measured and recorded at a point close to the inlet port.

5 Test procedure

5.1 Core preparation

Mechanical preparation of the core shall be carried out so as to minimize any alteration of its permeability (such as by grinding and polishing the core surface). The core shall be saturated with the base fluid or

a synthetic formation fluid (examples include KCl, NH₄Cl or other brines). If the formation fluid is not known, the core shall be saturated using a non-reactive solution.

5.2 Round cell

5.2.1 Prepare a core with minimum dimensions of 25,4 mm (1 in) in length by 25,4 mm (1 in) in diameter.

5.2.2 Saturate the core and record liquid permeability.

5.2.3 Prepare the test fluid and record fluid properties (for example in accordance with ISO 13503-1).

5.2.4 Set the backpressure, typically 690 kPa (100 psi) or greater, to satisfy a desired pressure differential across the core during the test (for example a minimum pressure differential of 6 900 kPa (1 000 psi) for tests on low-permeability cores).

5.2.5 Heat the cell to the test temperature.

5.2.6 Fluid should enter and exit the cell in a uniform flow regime so as to minimize entrance and exit effects. The distance between the core face and any loop curvature before fluid enters or exits the cell should be at least 2,5 times the diameter of the loop.

5.2.7 Initialize flow across the core face at the desired shear rate with the leakoff valve closed.

5.2.8 Monitor fluid temperature, fluid rate, pressure differential and fluid properties such as pH and viscosity before the fluid enters the cell.

5.2.9 Open the leakoff valve and start collecting fluid leakoff data at a minimum frequency of one data point per minute for at least 60 min. The volume is collected in a container, making sure the evaporation is minimized (the volume may be calculated from fluid mass by collecting fluid in a tared container).

5.3 Proppant conductivity cell

5.3.1 Prepare cores to fit the proppant conductivity cell with a minimum thickness of 9,5 mm (3/8 in).

5.3.2 Saturate the core and record liquid permeability.

5.3.3 Prepare the test fluid (for example in accordance with ISO 13503-1).

5.3.4 Set the backpressure, typically 690 kPa (100 psi) or greater, to satisfy a desired pressure differential across the core during the test (for example a minimum pressure differential of 6 900 kPa (1 000 psi) for tests on low-permeability cores).

5.3.5 Heat the cell to the test temperature.

5.3.6 Initialize flow across the core face at the desired shear rate and with the leakoff valve closed.

5.3.7 Monitor fluid temperature, fluid rate, pressure differential and fluid properties such as pH and viscosity before the fluid enters the cell.

5.3.8 Open the leakoff valve and start collecting fluid leakoff data at a minimum frequency of one data point per minute for at least 60 min. The volume is collected in a container, making sure the evaporation is minimized (the volume may be calculated from fluid mass by collecting fluid in a tared container).

6 Calculations

6.1 Shear rate

The shear rate in the slot across the core face is calculated by Formula (1) in SI units or Formula (2) in USC units:

$$\dot{\gamma} = \frac{6Q}{h^2 w} \quad (1)$$

$$\dot{\gamma} = \frac{0,93Q}{h^2 w} \quad (2)$$

where

- $\dot{\gamma}$ is the shear rate in the gap, expressed in s^{-1} ;
- Q is the fluid flow rate, expressed in ml/s;
- h is the gap height, expressed in cm (in);
- w is the gap width, expressed in cm (in).

NOTE For the purposes of Formulae (1) and (2), it is considered that 1 ml is equal to 1 cm³.

6.2 Leakoff coefficients

Dynamic fluid loss testing consists of a simulation of a downhole process where fluid loss occurs at a core face. The cumulative fluid loss volume per unit area of exposed core, V_C , can be expressed using three leakoff parameters versus filtration time, t :

- a dynamic coefficient, C_d , proportional to time;
- a wall-building coefficient, C_w , proportional to the square root of time;
- a constant parameter, the spurt loss, S_L .

The leakoff coefficients are calculated from a plot of leakoff filtrate volume, in millilitres, per cross-sectional area of the core face, in square centimetres, versus the square root of time, in minutes. The collected data are then reduced using polynomial regression where: V_C is the dependent variable while time and square root of time are the independent variables. Coefficients C_d , C_w and S_L are determined by numerical regression.

The relationship between leakoff coefficients is given by Formula (3):

$$V_C = S_L + C_d \times t + C_w \times t^{1/2} \quad (3)$$

where

V_C is the cumulative fluid volume per unit area of exposed core, expressed in ml/cm²;

C_d is the dynamic effect coefficient, expressed in ml/(cm²·min), a unit equivalent to cm/min;

C_w is the wall-building coefficient, expressed in ml/(cm²·min^{1/2}), a unit equivalent to cm/min^{1/2};

S_L is the spurt loss, expressed in ml/cm², unit equivalent to cm.

These three leakoff coefficient values can be calculated in SI units as follows:

$$C_{d,SI} = 1,667 \times 10^{-4} C_d$$

where $C_{d,SI}$ is the dynamic effect coefficient, expressed in m/s.

$$C_{w,SI} = 1,291 \times 10^{-3} C_w$$

where $C_{w,SI}$ is the wall-building coefficient, expressed in m/s^{1/2}.

$$S_{L,SI} = 0,01 \times S_L$$

where $S_{L,SI}$ is the spurt loss, expressed in m.

In USC units, the conversion equations are:

$$C_{d,USC} = 3,281 \times 10^{-2} C_d$$

where $C_{d,USC}$ is the dynamic effect coefficient, expressed in ft/min.

$$C_{w,USC} = 3,281 \times 10^{-2} C_w$$

where $C_{w,USC}$ is the wall-building coefficient, expressed in ft/min^{1/2}.

$$S_{L,USC} = 0,245 4 \times S_L$$

where $S_{L,USC}$ is the spurt loss, expressed in gal/ft².

7 Calculation examples

7.1 Round cell — Linear gel

7.1.1 Gel and test conditions

Gelled fluid system	Linear CMHPG 4,2 kg/m ³ (35 lb/Mgal)
Core type	Ohio SS – 0,45 mD OD: 38 mm (1,5 in)
Leakoff area	11,4 cm ² (1,77 in ²)
Test temperature	82 °C (180 °F)
Test pressure	6 900 kPa (1 000 psi)
Shear rate	40 s ⁻¹

7.1.2 Dynamic fluid loss data

Figure 3 shows an example of dynamic fluid loss data.

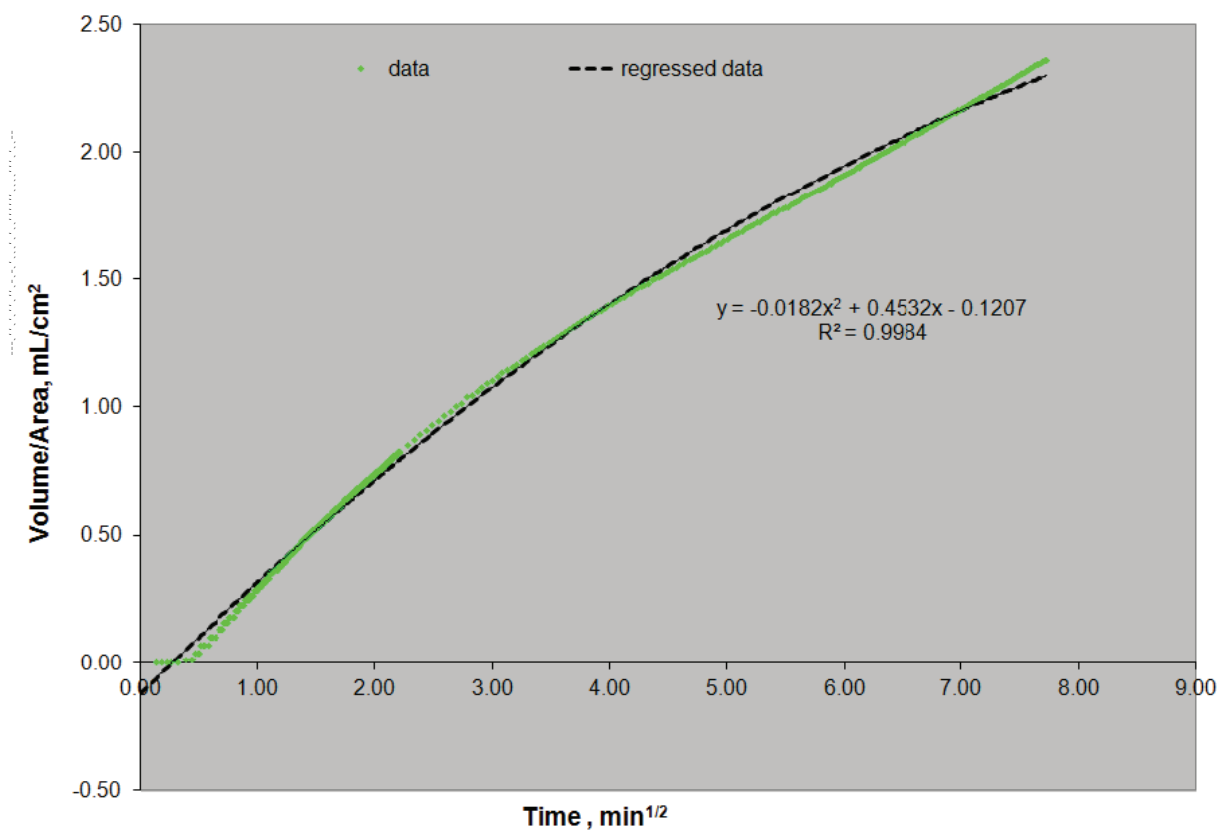

Figure 3 — Dynamic fluid loss example — 4,2 kg/m³ CMHPG (35 lb/Mgal) at 82 °C (180 °F), 6 900 kPa (1 000 psi)

7.1.3 Calculations

From the indicated regression analysis in Figure 3:

$$C_d = -0,018 \text{ 2 ml}/(\text{cm}^2 \text{ -min}) \quad \text{and} \quad C_{d,SI} = -3,03 \times 10^{-6} \text{ m/s} \quad C_{d,USC} = -0,000 \text{ 60 ft/min}$$

$$C_w = 0,453 \text{ 2 ml}/(\text{cm}^2 \text{ - min}^{1/2}) \quad \text{and} \quad C_{w,SI} = 0,585 \times 10^{-3} \text{ m/s}^{1/2} \quad C_{w,USC} = 0,015 \text{ ft/min}^{1/2}$$

$$S_L = -0,120 \text{ 7 ml}/\text{cm}^2$$

A negative spurt loss is a mathematical expression and should be reported as zero:

$$S_{L,SI} = S_{L,USC} = 0$$

7.2 Round cell — Crosslinked gel

7.2.1 Gel and test conditions

Gelled fluid system	Zr/CMHPG 4,2 kg/m ³ (35 lb/Mgal)
Core type	Ohio SS – 0,45 mD OD: 38 mm (1,5 in)
Leakoff area	11,4 cm ² (1,77 in ²)
Test temperature	121 °C (250 °F)
Test pressure	6 900 kPa (1 000 psi)
Shear rate	40 s ⁻¹

7.2.2 Dynamic fluid loss data

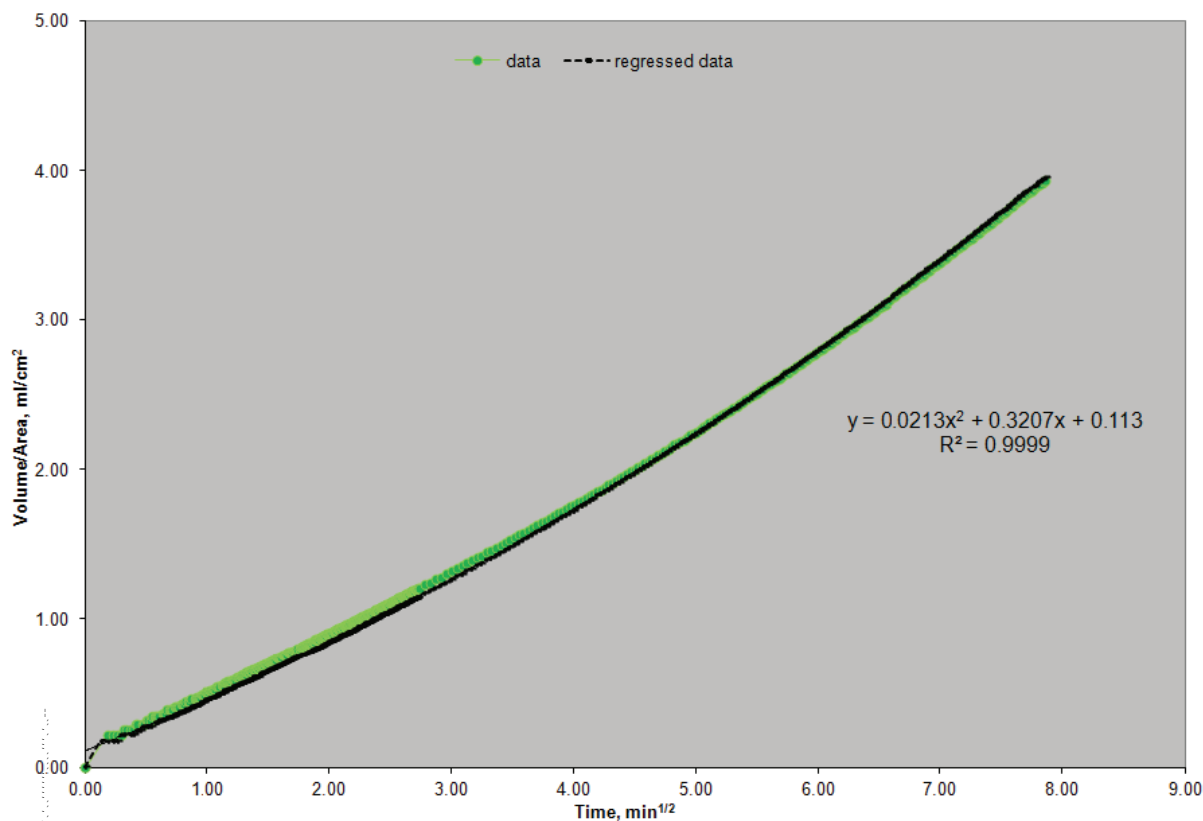

Figure 4 — Dynamic fluid loss example — 4,2 kg/m³ (35 lb/Mgal) Zr/CMHPG, at 121 °C (250 °F), 6 900 kPa (1 000 psi)

7.2.3 Calculations

From the indicated regression analysis in Figure 4:

$$C_d = 0,021\ 3\ \text{ml}/(\text{cm}^2\ \text{-min}) \quad \text{and} \quad C_{d,SI} = 3,15 \times 10^{-6}\ \text{m/s} \quad C_{d,USC} = -0,000\ 62\ \text{ft}/\text{min}$$

$$C_w = 0,320\ 7\ \text{ml}/(\text{cm}^2\ \text{-min}^{1/2}) \quad \text{and} \quad C_{w,SI} = 0,422 \times 10^{-3}\ \text{m}/\text{s}^{1/2} \quad C_{w,USC} = 0,011\ \text{ft}/\text{min}^{1/2}$$

$$S_L = 0,113\ \text{ml}/\text{cm}^2 \quad \text{and} \quad S_{L,SI} = 1,64 \times 10^{-3}\ \text{m} \quad S_{L,USC} = 0,040\ 3\ \text{gal}/\text{ft}^2$$

7.3 Proppant conductivity cell — Crosslinked gel

7.3.1 Gel and tests conditions

Gelled fluid system	Zr/CMHPG 4,2 kg/m ³ (35 lb/Mgal)
Core type	Ohio SS – 0,1 mD
Leakoff area	129 cm ² (20 in ²)
Test temperature	93 °C (200 °F)
Test pressure	6 900 kPa (1 000 psi)
Shear rate	40 s ⁻¹

7.3.2 Dynamic fluid loss data

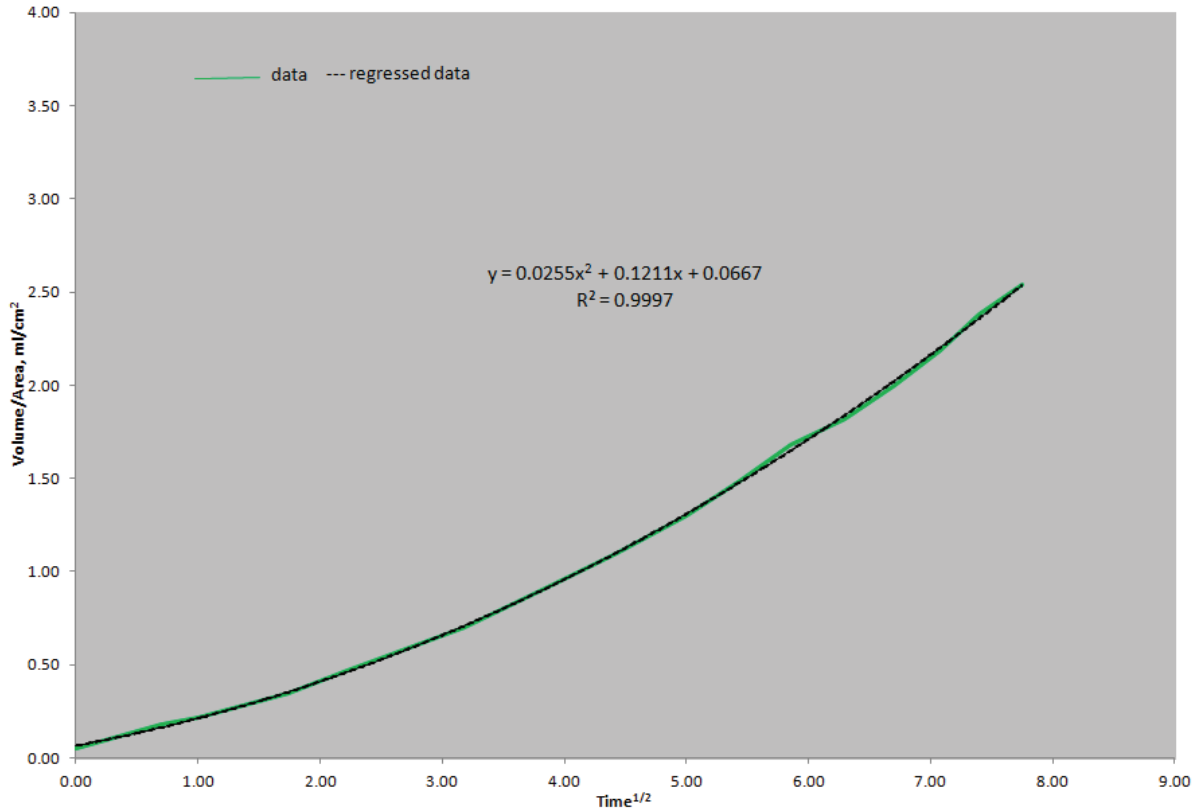

Figure 5 — Dynamic fluid loss example — 4,2 kg/m³ (35 lb/Mgal) Zr/CMHPG, at 93 °C (200 °F), 6 900 kPa (1 000 psi)

7.3.3 Calculations

From the indicated regression analysis in the Figure 5:

$$\begin{array}{lll} C_d = 0,025\ 5\ \text{ml}/(\text{cm}^2 \cdot \text{min}) & \text{and } C_{d,\text{SI}} = 4,03 \times 10^{-6}\ \text{m/s} & C_{d,\text{USC}} = 0,000\ 79\ \text{ft}/\text{min} \\ C_w = 0,121\ 1\ \text{ml}/(\text{cm}^2 \cdot \text{min}^{1/2}) & \text{and } C_{w,\text{SI}} = 0,171 \times 10^{-3}\ \text{m/s}^{1/2} & C_{w,\text{USC}} = 0,004\ 3\ \text{ft}/\text{min}^{1/2} \\ S_L = 0,066\ 7\ \text{ml}/\text{cm}^2 & \text{and } S_{L,\text{SI}} = 0,465 \times 10^{-3}\ \text{m} & S_{L,\text{USC}} = 0,011\ 4\ \text{gal}/\text{ft}^2 \end{array}$$

8 Report

Report the following if applicable:

- a) core:
 - 1) core mineralogy;
 - 2) core preparation;
 - 3) core orientation to bedding;
 - 4) core permeability;
 - 5) core dimensions;
 - 6) exposed surface area and position relative to flow;
- b) cell:
 - 1) type;
 - 2) gap width;
 - 3) core-holder orientation:
 - i) horizontal;
 - ii) vertical (upward flow/downward flow);
- c) fluid:
 - 1) composition and preparation;
 - 2) filtrate viscosity;
- d) test conditions:
 - 1) flow rate;
 - 2) fluid volume;
 - 3) shear history;
 - 4) shear rate (in the gap and flow system);
 - 5) fluid temperature (inlet and outlet);
 - 6) pressures;

- e) dynamic leakoff data:
 - 1) volume versus time;
 - 2) temperatures;
- f) calculations and results:
 - 1) volume/area versus square root of time plot;
 - 2) regression analysis results;
 - 3) dynamic leakoff coefficients calculations.

Bibliography

- [1] ISO 13503-1:2011, *Petroleum and natural gas industries — Completion fluids and materials — Part 1: Measurement of viscous properties of completion fluids*
- [2] ISO 13503-5:2006, *Petroleum and natural gas industries — Completion fluids and materials — Part 5: Procedures for measuring the long-term conductivity of proppants*

www.iso.org

ICS 75.100

Price based on 14 pages